

The revision list can be viewed directly by clicking the title page.

The revision list summarizes the locations of revisions and additions. Details should always be checked by referring to the relevant text.

16

H8S/2639, H8S/2638, H8S/2636, H8S/2630, H8S/2635 Group Hardware Manual

Renesas 16-Bit Single-Chip Microcomputer
H8S Family/H8S/2600 Series

Keep safety first in your circuit designs!

1. Renesas Technology Corp. puts the maximum effort into making semiconductor products better and more reliable, but there is always the possibility that trouble may occur with them. Trouble with semiconductors may lead to personal injury, fire or property damage.
Remember to give due consideration to safety when making your circuit designs, with appropriate measures such as (i) placement of substitutive, auxiliary circuits, (ii) use of nonflammable material or (iii) prevention against any malfunction or mishap.

Notes regarding these materials

1. These materials are intended as a reference to assist our customers in the selection of the Renesas Technology Corp. product best suited to the customer's application; they do not convey any license under any intellectual property rights, or any other rights, belonging to Renesas Technology Corp. or a third party.
2. Renesas Technology Corp. assumes no responsibility for any damage, or infringement of any third-party's rights, originating in the use of any product data, diagrams, charts, programs, algorithms, or circuit application examples contained in these materials.
3. All information contained in these materials, including product data, diagrams, charts, programs and algorithms represents information on products at the time of publication of these materials, and are subject to change by Renesas Technology Corp. without notice due to product improvements or other reasons. It is therefore recommended that customers contact Renesas Technology Corp. or an authorized Renesas Technology Corp. product distributor for the latest product information before purchasing a product listed herein.
The information described here may contain technical inaccuracies or typographical errors. Renesas Technology Corp. assumes no responsibility for any damage, liability, or other loss rising from these inaccuracies or errors.
Please also pay attention to information published by Renesas Technology Corp. by various means, including the Renesas Technology Corp. Semiconductor home page (<http://www.renesas.com>).
4. When using any or all of the information contained in these materials, including product data, diagrams, charts, programs, and algorithms, please be sure to evaluate all information as a total system before making a final decision on the applicability of the information and products. Renesas Technology Corp. assumes no responsibility for any damage, liability or other loss resulting from the information contained herein.
5. Renesas Technology Corp. semiconductors are not designed or manufactured for use in a device or system that is used under circumstances in which human life is potentially at stake. Please contact Renesas Technology Corp. or an authorized Renesas Technology Corp. product distributor when considering the use of a product contained herein for any specific purposes, such as apparatus or systems for transportation, vehicular, medical, aerospace, nuclear, or undersea repeater use.
6. The prior written approval of Renesas Technology Corp. is necessary to reprint or reproduce in whole or in part these materials.
7. If these products or technologies are subject to the Japanese export control restrictions, they must be exported under a license from the Japanese government and cannot be imported into a country other than the approved destination.
Any diversion or reexport contrary to the export control laws and regulations of Japan and/or the country of destination is prohibited.
8. Please contact Renesas Technology Corp. for further details on these materials or the products contained therein.

Preface

This LSI has the internal 32-bit H8S/2600 CPU and includes a variety of peripheral functions necessary for a system configuration. It serves as a high-performance microcomputer.

The on-chip peripheral devices include a 16-bit timer pulse unit (TPU), a programmable pulse generator (PPG), a watchdog timer unit (WDT), a serial communication interface (SCI), an A/D converter, a motor control PWM timer (PWM), a PC brake controller and I/O ports. It also has an internal data transfer controller (DTC), which performs high-speed data transfer without using the CPU, thus enabling the use of the LSI as an embedded microcomputer in various advanced control systems. Two types of internal ROM are available: flash memory (F-ZTAT™*) and mask ROM. The LSI can be used flexibly in a wide range of applications from applied equipment with varied specifications and early production models to full-scale mass-produced products.

Notes: The H8S/2635 and H8S/2634 are not equipped with a PPG, a PC brake controller, or a DTC.

* F-ZTAT is a trademark of Renesas Technology Corp.

Target users: This manual was written for users who will be using the H8S/2636, H8S/2638, H8S/2639, H8S/2630, H8S/2635, and H8S/2634 in the design of application systems. Members of this audience are expected to understand the fundamentals of electrical circuits, logical circuits, and microcomputers.

Objective: This manual was written to explain the hardware functions and electrical characteristics of the H8S/2636, H8S/2638, H8S/2639, H8S/2630, H8S/2635, and H8S/2634 to the above audience. Refer to the H8S/2600 Series, H8S/2000 Series Programming Manual for a detailed description of the instruction set.

Notes on reading this manual:

- In order to understand the overall functions of the chip
Read the manual according to the contents. This manual can be roughly categorized into parts on the CPU, system control functions, peripheral functions and electrical characteristics.
- In order to understand the details of the CPU's functions
Read the H8S/2600 Series, H8S/2000 Series Programming Manual.
- In order to understand the details of a register when its name is known
The addresses, bits, and initial values of the registers are summarized in Appendix B, Internal I/O Registers.
Example: Bit order: The MSB is on the left and the LSB is on the right.

Related manuals: The latest versions of all related manuals are available from our web site.
Please ensure you have the latest versions of all documents you require.
<http://www.renesas.com/>

H8S/2636, H8S/2638, H8S/2639, H8S/2630, H8S/2635 Group manuals:

Document Title	Document No.
H8S/2636, H8S/2638, H8S/2639, H8S/2630, H8S/2635 Hardware Manual	This manual
H8S/2600 Series, H8S/2000 Series Programming Manual	REJ09B0139

User's manuals for development tools:

Document Title	Document No.
H8S, H8/300 Series C/C++ Compiler, Assembler, Optimized Linkage Editor User's Manual	REJ10B0058
H8S, H8/300 Series Simulator/Debugger (for Windows) User's Manual	ADE-702-037
H8S, H8/300 Series High-performance Embedded Workshop User's Manual	ADE-702-201

Application Notes:

Document Title	Document No.
H8S Family Technical Q & A	REJ05B0397

Main Revisions in This Edition

Item	Page	Revision (See Manual for Details)												
All		H8S/2635 and H8S/2634 added												
Preface	iii	<p>Note amended</p> <p>Notes: The H8S/2635 and H8S/2634 are not equipped with a PPG, a PC brake controller, or a DTC.</p> <p>* F-ZTAT is a trademark of Renesas Technology Corp.</p> <p>Target users: This manual was written for users who will be using the H8S/2636, H8S/2638, H8S/2639, H8S/2630, H8S/2635, and H8S/2634 in the design of application systems.</p> <p>...</p>												
1.1 Overview	1	<p>Description amended</p> <p>The H8S/2636, H8S/2638, H8S/2639, H8S/2630, H8S/2635, and H8S/2634 are microcomputers (MCUs: microcomputer units), built around ... On-chip ROM is available as 128-kbyte, 192-kbyte, 256-kbyte, and 384-kbyte flash memory (F-ZTATTM* version), and as 128-kbyte, 192-kbyte, 256-kbyte, and 384-kbyte mask ROM. ... The features of the H8S/2636, H8S/2638, H8S/2639, H8S/2630, H8S/2635, and H8S/2634 are shown in table 1-1.</p> <p>Notes: The H8S/2635 and H8S/2634 are not equipped with a DTC, a PPG, or a D/A converter.</p> <p>* F-ZTAT is a trademark of Renesas Technology Corp.</p>												
Table 1-1 Overview	2	<p>Item in table 1-1 amended</p> <p>PC break controller (This function is not implemented in the H8S/2635 Group) Data transfer controller (DTC) (This function is not implemented in the H8S/2635 Group)</p>												
	3	<p>Programmable pulse generator (PPG) (This function is not implemented in the H8S/2635 Group)</p> <p>Controller area network (HCAN) 2 channels (The H8S/2635 Group has one HCAN channels)</p> <p>D/A converter (This function is not implemented in the H8S/2635 Group)</p>												
	4	<p>Memory</p> <table border="1"> <thead> <tr> <th>Product Name</th> <th>ROM</th> <th>RAM</th> </tr> </thead> <tbody> <tr> <td>H8S/2630*</td> <td>384 kbytes</td> <td>16 kbytes</td> </tr> <tr> <td>H8S/2635</td> <td>192 kbytes</td> <td>6 kbytes</td> </tr> <tr> <td>H8S/2634</td> <td>128 kbytes</td> <td></td> </tr> </tbody> </table>	Product Name	ROM	RAM	H8S/2630*	384 kbytes	16 kbytes	H8S/2635	192 kbytes	6 kbytes	H8S/2634	128 kbytes	
Product Name	ROM	RAM												
H8S/2630*	384 kbytes	16 kbytes												
H8S/2635	192 kbytes	6 kbytes												
H8S/2634	128 kbytes													

Item	Page	Revision (See Manual for Details)																																						
1.1 Overview	4	Item in table 1-1 amended																																						
Table 1-1 Overview		Interrupt controller <ul style="list-style-type: none"> • 49 interrupt sources (45 sources in H8S/2635) 																																						
	5	Clock pulse generator <ul style="list-style-type: none"> • Input clock frequency H8S/2636, H8S/2638, H8S/2630: 4 to 20 MHz H8S/2639, H8S/2635, H8S/2634: 4 to 5 MHz																																						
		Product lineup																																						
		<table border="1"> <thead> <tr> <th colspan="2">Model Name</th> <th rowspan="2">Subclock Functions</th> <th rowspan="2">I²C bus interface</th> <th rowspan="2">ROM/ RAM (Bytes)</th> <th rowspan="2">Packages</th> </tr> <tr> <th>Mask ROM Version</th> <th>F-ZTAT Version</th> </tr> </thead> <tbody> <tr> <td>HD6432630F</td> <td>HD64F2630F</td> <td>No</td> <td>No</td> <td>384 k/</td> <td>16 k</td> </tr> <tr> <td>HD6432630UF (U-Mask Version)</td> <td>HD64F2630UF (U-Mask Version)</td> <td>Yes</td> <td>No</td> <td></td> <td></td> </tr> <tr> <td>HD6432630WF (W-Mask Version)</td> <td>HD64F2630WF (W-Mask Version)</td> <td>Yes</td> <td>Yes</td> <td></td> <td></td> </tr> <tr> <td>HD6432635F</td> <td>HD64F2635F</td> <td>Yes</td> <td>No</td> <td>192 k/</td> <td>6 k</td> </tr> <tr> <td>HD6432634F</td> <td>—</td> <td>Yes</td> <td>No</td> <td>128 k/</td> <td>6 k</td> </tr> </tbody> </table>	Model Name		Subclock Functions	I ² C bus interface	ROM/ RAM (Bytes)	Packages	Mask ROM Version	F-ZTAT Version	HD6432630F	HD64F2630F	No	No	384 k/	16 k	HD6432630UF (U-Mask Version)	HD64F2630UF (U-Mask Version)	Yes	No			HD6432630WF (W-Mask Version)	HD64F2630WF (W-Mask Version)	Yes	Yes			HD6432635F	HD64F2635F	Yes	No	192 k/	6 k	HD6432634F	—	Yes	No	128 k/	6 k
Model Name		Subclock Functions	I ² C bus interface	ROM/ RAM (Bytes)					Packages																															
Mask ROM Version	F-ZTAT Version																																							
HD6432630F	HD64F2630F	No	No	384 k/	16 k																																			
HD6432630UF (U-Mask Version)	HD64F2630UF (U-Mask Version)	Yes	No																																					
HD6432630WF (W-Mask Version)	HD64F2630WF (W-Mask Version)	Yes	Yes																																					
HD6432635F	HD64F2635F	Yes	No	192 k/	6 k																																			
HD6432634F	—	Yes	No	128 k/	6 k																																			
		Note * amended																																						
		Note: * Subclock functions (subactive mode, subsleep mode, and watch mode) are available only in the U-mask and W-mask versions, and H8S/2635 Group, but are not in the other versions.																																						
1.2 Internal Block Diagram	8	Figure added																																						
Figure 1-1 (c) Internal Block Diagram of H8S/2635 Group																																								
1.3.1 Pin Arrangement	9	Note added																																						
Figure 1-2 Pin Arrangement of H8S/2636 Group (FP-128B: Top View)		Notes: PPG and D/A converter pin functions not implemented. 1. Connect a 0.1 μF capacitor between VCL and VSS (close to the pins). ...																																						
Figure 1-3 Pin Arrangement of H8S/2638 Group and H8S/2630 Group (FP-128B: Top View)	10	Notes: The PPG and D/A converter pin functions not implemented. 1. Connect a 0.1 μF capacitor between VCL and VSS (close to the pins). ...																																						

1.3.1 Pin Arrangement 12 Figure 1-5 added

Figure 1-5 Pin Arrangement of H8S/2635 Group (FP-128B: Top View)

1.3.2 Pin Functions in Each Operating Mode 14 Table amended, note *4 added

Table 1-2 Pin Functions in Each Operating Mode

Pin No.	Pin Name			
	Mode 4	Mode 5	Mode 6	Mode 7
27	PE7/D7	PE7/D7	PE7/D7	PE7
28	PE6/D6	PE6/D6	PE6/D6	PE6
29	PE5/D5	PE5/D5	PE5/D5	PE5
30	PE4/D4	PE4/D4	PE4/D4	PE4
31	PE3/D3	PE3/D3	PE3/D3	PE3
32	PE2/D2	PE2/D2	PE2/D2	PE2
33	PE1/D1	PE1/D1	PE1/D1	PE1
34	PE0/D0	PE0/D0	PE0/D0	PE0
42	LWR/ADTRG/IRQ3	PF3/LWR/ADTRG/IRQ3	PF3/LWR/ADTRG/IRQ3	PF3/ADTRG/IRQ3

16

Pin No.	Pin Name			
	Mode 4	Mode 5	Mode 6	Mode 7
89	P10/PO8 ^{*4} /TIOCA0/A20	P10/PO8 ^{*4} /TIOCA0/A20	P10/PO8 ^{*4} /TIOCA0/A20	P10/PO8 ^{*4} /TIOCA0
90	P11/PO9 ^{*4} /TIOCB0/A21	P11/PO9 ^{*4} /TIOCB0/A21	P11/PO9 ^{*4} /TIOCB0/A21	P11/PO9 ^{*4} /TIOCB0
91	P12/PO10 ^{*4} /TIOCC0/TCLKA/A22	P12/PO10 ^{*4} /TIOCC0/TCLKA/A22	P12/PO10 ^{*4} /TIOCC0/TCLKA/A22	P12/PO10 ^{*4} /TIOCC0/TCLKA
92	P13/PO11 ^{*4} /TIOCD0/TCLKB/A23	P13/PO11 ^{*4} /TIOCD0/TCLKB/A23	P13/PO11 ^{*4} /TIOCD0/TCLKB/A23	P13/PO11 ^{*4} /TIOCD0/TCLKB
93	P14/PO12 ^{*4} /TIOCA1/IRQ0	P14/PO12 ^{*4} /TIOCA1/IRQ0	P14/PO12 ^{*4} /TIOCA1/IRQ0	P14/PO12 ^{*4} /TIOCA1/IRQ0
94	P15/PO13 ^{*4} /TIOCB1/TCLKC	P15/PO13 ^{*4} /TIOCB1/TCLKC	P15/PO13 ^{*4} /TIOCB1/TCLKC	P15/PO13 ^{*4} /TIOCB1/TCLKC
95	P16/PO14 ^{*4} /TIOCA2/IRQ1	P16/PO14 ^{*4} /TIOCA2/IRQ1	P16/PO14 ^{*4} /TIOCA2/IRQ1	P16/PO14 ^{*4} /TIOCA2/IRQ1
96	P17/PO15 ^{*4} /TIOCB2/TCLKD	P17/PO15 ^{*4} /TIOCB2/TCLKD	P17/PO15 ^{*4} /TIOCB2/TCLKD	P17/PO15 ^{*4} /TIOCB2/TCLKD
109	P46/AN6/DA0 ^{*4}	P46/AN6/DA0 ^{*4}	P46/AN6/DA0 ^{*4}	P46/AN6/DA0 ^{*4}
110	P47/AN7/DA1 ^{*4}	P47/AN7/DA1 ^{*4}	P47/AN7/DA1 ^{*4}	P47/AN7/DA1 ^{*4}

17

Notes amended

Notes: 1. Subclock functions (subactive mode, subsleep mode, and watch mode) are available in the U-mask and W-mask versions, and H8S/2635 Group. ... The H8S/2639 and H8S/2635 Groups have no OSC1 and OSC2 pins.

4. The PPG output, DA0, and DA1 are not supported in H8S/2635 Group.

Item	Page	Revision (See Manual for Details)
1.3.3 Pin Functions	18	Name and function amended
Table 1-3 Pin Functions		XTAL Crystal: Connects to a crystal oscillator. ...
		----- EXTAL External clock: Connects to a crystal oscillator. ...
	21	AVCC Analog power supply: A/D converter and D/A converter power supply pin. ...
		----- AVSS Analog ground: Ground pin for A/D converter and D/A converter. ... ----- Vref Analog reference power supply: A/D converter and D/A converter reference voltage input pin. ...
	18, 20,	Table 1-3 amended
	21	HTxD1*3 HRxD1*3 PO15 to PO8*4 DA1, DA0*5
	22	Notes amended Notes: 1. Subclock functions (subactive mode, subsleep mode, and watch mode) are available in the U-mask and W-mask versions, and H8S/2635 Group. ... The H8S/2639 and H8S/2635 Groups have no OSC1 and OSC2 pins. 3. The HTxD1 and HRxD1 pins are not supported in the H8S/2635 Group. 4. The PO15 to 8 output are not supported in the H8S/2635 Group. 5. The DA1 and DA0 output are not supported in the H8S/2635 Group.
1.4 Differences between H8S/2636, H8S/2638, H8S/2639, H8S/2630, H8S/2635, and H8S/2634	23	1.4 title amended

1.4 Differences

23

Table 1-4 amended

between H8S/2636,
H8S/2638, H8S/2639,
H8S/2630, H8S/2635,
and H8S/2634

Table 1-4 Comparison
of Product
Specifications

Product Type	Model	Product Specifications						
		ROM	RAM	Subclock Function	I ² C Bus Interface	HCAN	DTC, PBC, PPG, DAC	Power-Down Modes
H8S/2636	HD64F2636F	128-kbyte on-chip flash memory	4-kbyte SRAM	No	No	2 channels	Yes	See section 23A, Power-Down Modes
	HD64F2636UF			Yes				
	HD6432636F	No		No				
	HD6432636UF	Yes						
H8S/2638	HD64F2638F	256-kbyte on-chip flash memory	16-kbyte SRAM	No	No			See section 23A, Power-Down Modes
	HD64F2638UF			Yes				
	HD64F2638WF				Yes			
	HD6432638F	256-kbyte mask ROM		No	No			
	HD6432638UF			Yes				
	HD6432638WF				Yes			

24

Product Type	Model	Product Specifications						
		ROM	RAM	Subclock Function	I ² C Bus Interface	HCAN	DTC, PBC, PPG, DAC	Power-Down Modes
H8S/2639*1	HD64F2639UF	256-kbyte on-chip flash memory	16-kbyte SRAM	Yes	No	2 channels	Yes	See section 23B, Power-Down Modes
	HD64F2639WF				Yes			
	HD6432639UF	256-kbyte mask ROM		No				
	HD6432639WF			Yes				
H8S/2630	HD64F2630F	384-kbyte on-chip flash memory	16-kbyte SRAM	No	No			See section 23A, Power-Down Modes
	HD64F2630UF							
	HD64F2630WF			Yes				
	HD6432630F	384-kbyte mask ROM		No	No			
	HD6432630UF			Yes				
HD6432630WF			Yes					
H8S/2635*1	HD64F2635F	192-kbyte on-chip flash memory	6-kbyte SRAM	Yes	No	1 channel	No	
	HD6432635F*2	192-kbyte mask ROM						
H8S/2634*1	HD6432634F*2	128-kbyte mask ROM						

Item	Page	Revision (See Manual for Details)
3.3.1 Mode 4	85	Description amended Ports 1, A, B, and C function as an address bus, ports D and E function as a data bus, and part of port F carries bus control signals.
3.3.2 Mode 5	85	Description amended Ports 1, A, B, and C function as an address bus, port D function as a data bus, and part of port F carries bus control signals.
3.3.3 Mode 6	85	Description amended Ports 1, A, B, and C function as input port pins immediately after a reset. Address output can be performed by setting the corresponding DDR (data direction register) bits to 1.
3.5 Address Map in Each Operating Mode	91	Figure 3-4 added
Figure 3-4 Memory Map in Each Operating Mode in the H8S/2635		
Figure 3-5 Memory Map in Each Operating Mode in the H8S/2634	92	Figure 3-5 added
4.1.1 Exception Handling Types and Priority	93	Note * amended Note: * Subclock functions (subactive mode, subsleep mode, and watch mode) are available in the U-mask and W-mask versions, and H8S/2635 Group only. ...
Table 4-1 Exception Types and Priority	93	Note 4 amended Note: 4. Subclock functions (subactive mode, subsleep mode, and watch mode) are available in the U-mask and W-mask versions, and H8S/2635 Group only. ...
4.1.3 Exception Vector Table	95	Note 3 amended Note: 3. ... Subclock functions are available in the U-mask and W-mask versions, and H8S/2635 Group only.
Table 4-2 Exception Vector Table		
4.4 Interrupts	100	Note added Note: The DTC, PBC, and IIC are not implemented in the H8S/2635 Group.
Figure 4-4 Interrupts Sources and Number of Interrupts	100	Note *3 added HCAN (4) ^{*3} Note: 3. 2 Sources in the H8S/2635 Group.

Item	Page	Revision (See Manual for Details)
5.1.1 Features	105	Note * added <ul style="list-style-type: none"> • DTC control* ... Note: * The H8S/2635 Group is not equipped with a DTC.
5.2 Register Descriptions	108	Note added Note: The H8S/2635 Group is not equipped with a DTC, a PC brake controller, or an HCAN1.
5.2.2 Interrupt Priority Registers A to H, J to M (IPRA to IPRH, IPRJ to IPRM) Table 5-3 Correspondence between Interrupt Sources and IPR Setting	109	Note *3 added DTC*3 PC break*3 HCAN channel 1*3 Note: 3. The PC break, DTC, and HCAN channel 1 are reserved in the H8S/2635 Group.
5.3 Interrupt Sources	114	Notes added Notes: The H8S/2635 Group is not equipped with a DTC, a PC break controller, or an HCAN1. The H8S/2635 has 45 sources of internal interrupt.
5.3.3 Interrupt Exception Handling Vector Table Table 5-4 Interrupt Sources, Vector Addresses, and Interrupt Priorities	117 120	Note *3 added DTC*3 PC break controller*3 HCAN*3 Note: 3. The DTC, PC break, and HCAN1 interrupts are reserved in the H8S/2635 Group.
5.6 DTC Activation by Interrupt	133	Note added Note: The DTC is not implemented in the H8S/2635 Group.
Section 6 PC Break Controller (PBC)	137	Note added Note: The H8S/2635 Group is not equipped with a PBC.
7.1 Overview	149	Note added Note: The DTC is not implemented in the H8S/2635 Group.
7.8 Bus Arbitration	187	Note added Note: The H8S/2635 Group is not equipped with a DTC.
Section 8 Data Transfer Controller (DTC)	189	Note added Note: The H8S/2635 Group is not equipped with a DTC.

Item **Page** **Revision (See Manual for Details)**

Table 9-1 Port Functions 224 Notes *2, *3 added

Port	Description	Pins	Mode 4	Mode 5	Mode 6	Mode 7
Port 3	<ul style="list-style-type: none"> • 6-bit I/O port • Open-drain output capability • Schmitt-triggered input (P35, P32) 	<ul style="list-style-type: none"> P35/SCK1/SCL0^{*2)}/IRQ5 P34/RxD1/SDA0^{*2)} P33/TxD1/SCL1^{*2)} P32/SCK0/SDA1^{*2)}/IRQ4 P31/RxD0 P30/TxD0 	6-bit I/O port also functioning as SCI (channel 0, 1) I/O pins (TxD0, RxD0, SCK0, TxD1, RxD1, SCK1), interrupt input pins (IRQ4, IRQ5), IIC (channel 0, 1) I/O pins (SCL0, SDA0, SCL1, SDA1) ^{*2)}			

Port

(Before) Port 1 → (After) Port 1 ^{*2}

(Before) Port 4 → (After) Port 4 ^{*3}

226 Note added

Notes: 1. I²C bus interface ... and H8S/2630.

2. The PPG output is not implemented in the H8S/2635 Group.

3. The DA output is not implemented in the H8S/2635 Group.

9.2 Port 1 227 Note added

Note: The PPG output is not implemented in the H8S/2635 Group.

9.2.3 Pin Functions 229 Note added

Note: The PPG output is not implemented in the H8S/2635 Group.

9.4 Port 4 248 Note added

Note: The DA output is not implemented in the H8S/2635 Group.

Section 10 16-Bit Timer Pulse Unit (TPU) 295 Note added

Note: The H8S/2635 Group is not equipped with a DTC or PPG.

10.5.2 DTC Activation 369 Note added

Note: The DTC is not implemented in the H8S/2635 and H8S/2634.

10.6.2 Interrupt Signal Timing 377 Status Flag Clearing Timing

Note * added

DTC*

Note: * The DTC is not implemented in the H8S/2635 and H8S/2634.

Item	Page	Revision (See Manual for Details)
10.7 Usage Notes	386	Figure 10-56 amended
Figure 10-56 Contention between Overflow and Counter Clearing		<p>The diagram shows a sequence of events: a clock signal ϕ is shown at the top. Below it, the TCNT input clock is active during a period where the TCNT value transitions from H'FFFF to H'0000. Simultaneously, a Counter clear signal is asserted. The TGF signal is also shown. The TCFV signal is shown to be 'Prohibited' during the counter clear signal.</p>
Figure 10-57 Contention between TCNT Write and Overflow	387	Figure 10-57 amended
		<p>The diagram shows a TCFV flag signal. A 'Prohibited' region is indicated for TCFV during the overflow event.</p>
	387	Interrupts and Module Stop Mode Note * added DTC*
		Note: *The DTC is not implemented in the H8S/2635 and H8S/2634.
Section 11 Programmable Pulse Generator (PPG)	389	Note added Note: The H8S/2635 Group is not equipped with a PPG.
12.1.1 Features	415	Notes amended
		Notes: 1. Other than the U-mask and W-mask versions, and H8S/2635 Group have eight types of counter input clock as well as WDT0. 2. Subclock functions (subactive mode, subsleep mode, and watch mode) are available in the U-mask and W-mask versions, and H8S/2635 Group only. ... The H8S/2639, H8S/2635 Groups have no OSC1 and OSC2 pins.
12.1.2 Block Diagram	416	Note 2 amended
Figure 12-1 (a) Block Diagram of WDT0		Note: 2. In the U-mask and W-mask versions, and H8S/2635 Group, ϕ in subactive and subsleep modes operates as ϕ SUB.

Item	Page	Revision (See Manual for Details)
12.1.2 Block Diagram Figure 12-1 (b) Block Diagram of WDT1	417	Note 2 amended Note: 2. Subclock functions (subactive mode, subsleep mode, and watch mode) are available in the U-mask and W-mask versions, and H8S/2635 Group only.
12.2.2 Timer Control/Status Register (TCSR)	420	TCSR1 Note 2 amended Note: 2. Subclock functions (subactive mode, subsleep mode, and watch mode) are available in the U-mask and W-mask versions, and H8S/2635 Group only.
	423	Bits 2 to 0—Clock Select 2 to 0 (CKS2 to CKS0) Note * amended Note: * Subclock functions (subactive mode, subsleep mode, and watch mode) are available in the U-mask and W-mask versions, and H8S/2635 Group only. ...
	424	WDT0 Input Clock Select Note 2 amended Note: 2. In the U-mask and W-mask versions, and H8S/2635 Group, ϕ in subactive and subsleep modes operates as ϕ SUB.
	425	WDT1 Input Clock Select Note 2 amended Note: 2. Subclock functions (subactive mode, subsleep mode, and watch mode) are available in the U-mask and W-mask versions, and H8S/2635 Group only. ...
12.3.1 Watchdog Timer Operation	429	Note * amended Note: * Subclock functions (subactive mode, subsleep mode, and watch mode) are available in the U-mask and W-mask versions, and H8S/2635 Group only. ...
12.5.2 Changing Value of PSS* and CKS2 to CKS0	434	Note * amended Note: * Subclock functions (subactive mode, subsleep mode, and watch mode) are available in the U-mask and W-mask versions, and H8S/2635 Group only. ...
Section 13 Serial Communication Interface (SCI)	435	Note added Note: The H8S/2635 Group is not equipped with a DTC.
13.2.2 Receive Data Register (RDR)	440	Note * amended Note: * Subclock functions (subactive mode, subsleep mode, and watch mode) are available in the U-mask and W-mask versions, and H8S/2635 Group only. ...

Item	Page	Revision (See Manual for Details)
13.2.4 Transmit Data Register (TDR)	441	<p>Note * amended</p> <p>Note: * Subclock functions (subactive mode, subsleep mode, and watch mode) are available in the U-mask and W-mask versions, and H8S/2635 Group only. ...</p>
13.2.7 Serial Status Register (SSR)	449	<p>Note * amended</p> <p>Note: * Subclock functions (subactive mode, subsleep mode, and watch mode) are available in the U-mask and W-mask versions, and H8S/2635 Group only. ...</p>
13.5 Usage Notes	497	<p>Note * added</p> <p>Restrictions on Use of DTC*</p> <p>Note: * The DTC is not implemented in the H8S/2635 and H8S/2634.</p> <hr/> <p>Operation in Case of Mode Transition</p> <ul style="list-style-type: none"> • Transmission <p>... Operation should also be stopped ... before making a transition from transmission by DTC* transfer to module stop mode, To perform transmission with the DTC* after the relevant mode is cleared, ... and start DTC* transmission.</p> <p>Note: * The DTC is not implemented in the H8S/2635 and H8S/2634.</p>
Section 14 Smart Card Interface	503	<p>Note added</p> <p>Note: The H8S/2635 Group is not equipped with a DTC.</p>
14.1.1 Features	503	<ul style="list-style-type: none"> • Three interrupt sources <p>Note * added</p> <p>—The transmit data empty interrupt and receive data full interrupt can activate the data transfer controller (DTC)* to execute data transfer</p> <p>Note: * The DTC is not implemented in the H8S/2635 and H8S/2634.</p>
14.3.6 Data Transfer Operations	523	<p>Serial Data Transmission (Except Block Transfer Mode)</p> <p>Note * added</p> <p>... If the DTC* is activated by a TXI request, the number of bytes set in the DTC can be transmitted automatically, including automatic retransmission. ...</p> <p>Note: * The DTC is not implemented in the H8S/2635 and H8S/2634.</p>

Item	Page	Revision (See Manual for Details)
14.3.6 Data Transfer Operations	527	Serial Data Reception (Except Block Transfer Mode) Note * added DTC* Note: * The DTC is not implemented in the H8S/2635 and H8S/2634.
	528, 529	Data Transfer Operation by DTC* Note * added Note: * The DTC is not implemented in the H8S/2635 and H8S/2634.
14.4 Usage Notes	533	Retransfer operations (Except Block Transfer Mode) • Retransfer operation when SCI is in receive mode Note * added [4] ... If DTC* data transfer by an RXI source is enabled, ... When the RDR data is read by the DTC*, the RDRF flag is automatically cleared to 0. Note: * The DTC is not implemented in the H8S/2635 and H8S/2634.
	534	• Retransfer operation when SCI is in transmit mode Note * added [9] ... If data transfer by the DTC* by means of the TXI source is enabled, ... When data is written to TDR by the DTC*, the TDRE bit is automatically cleared to 0. Note: * The DTC is not implemented in the H8S/2635 and H8S/2634.
15.4 Usage Notes	599, 600	• Notes on Arbitration Lost in Master Mode Description added
	—	• Notes on loss of arbitration Description deleted
Section 16 Controller Area Network (HCAN)	601	Note added Notes: The H8S/2635 Group is not equipped with a DTC. Only a single HCAN channel, HCAN0, is implemented in the H8S/2635 Group.

Item	Page	Revision (See Manual for Details)
16.1.3 Pin Configuration Table 16-1 HCAN Pins	604	Note * added Channel 1* Notes: * The HCAN1 is not supported by the H8S/2635 and H8S/2634.
16.1.4 Register Configuration Table 16-2 HCAN Registers	605 to 608	Note *2 added Address*1 Channel 1*2 Notes: 1. Lower 16 bits of the address. 2. The HCAN1 is not supported by the H8S/2635 and H8S/2634.
16.2.20 Module Stop Control Register C (MSTPCRC)	640	Note * added MSTPC2* Note: * The MSTPC2 is not available and is reserved in the H8S/2635 and H8S/2634.
	640	Bit 2—Module Stop (MSTPC2)* Note: * The MSTPC2 is not available and is reserved in the H8S/2635 and H8S/2634.
16.3.8 DTC Interface*	665	Note * added Note: * The DTC is not implemented in the H8S/2635 and H8S/2634.
Section 17 A/D Converter	671	Note added Note: The H8S/2635 Group is not equipped with a DTC.
Section 18 D/A Converter	695	Note added Note: The H8S/2635 Group is not equipped with a D/A converter.

Item	Page	Revision (See Manual for Details)
Section 19 Motor Control PWM Timer	703	Note added Note: The H8S/2635 Group is not equipped with a DTC.
19.2.2 PWM Output Control Registers 1 and 2 (PWOCR1, PWOCR2)	710	Note * amended Note: * Subclock functions (subactive mode, subsleep mode, and watch mode) are available in the U-mask and W-mask versions, and H8S/2635 Group only. ...
19.2.3 PWM Polarity Registers 1 and 2 (PWPR1, PWPR2)	711	
19.2.4 PWM Counters 1 and 2 (PWCNT1, PWCNT2)	712	
19.2.5 PWM Cycle Registers 1 and 2 (PWCYR1, PWCYR2)	713	
19.2.6 PWM Duty Registers 1A, 1C, 1E, 1G (PWDTR1A, 1C, 1E, 1G)	714	
19.2.7 PWM Buffer Registers 1A, 1C, 1E, 1G (PWBFR1A, 1C, 1E, 1G)	716	
19.2.8 PWM Duty Registers 2A to 2H (PWDTR2A to PWDTR2H)	717	
19.2.9 PWM Buffer Registers 2A to 2D (PWBFR2A to PWBFR2D)	719	
19.5 Usage Note	725	Note * added Buffer register rewriting must be completed before automatic transfer by the DTC* (data transfer controller), ... Note: * The DTC is not implemented in the H8S/2635 and H8S/2634.
Section 20 RAM	727	Note added Note: The H8S/2635 Group is not equipped with a DTC.

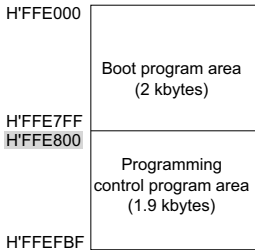
Item	Page	Revision (See Manual for Details)
20.1 Overview	727	<p>Description amended</p> <p>The H8S/2636 has 4 kbytes, and H8S/2638, H8S/2639, and H8S/2630 have 16 kbytes of on-chip high-speed static RAM. The H8S/2635 Group has 6 kbytes of on-chip RAM. The RAM is connected to the CPU by a 16-bit data bus, enabling one-state access by the CPU to both byte data and word data. This makes it possible to perform fast word data transfer.</p>
20.1.1 Block Diagram Figure 20-1 (c) Block Diagram of RAM (H8S/2635 Group)	729	Figure 20-1 (c) added
20.3 Operation	730	<p>Description amended</p> <p>When the RAME bit is set to 1, accesses to addresses H'FFE000 to H'FFEFBF (for the H8S/2636), H'FFB000 to H'FFEFBF (for the H8S/2638, H8S/2639, and H8S/2630), H'FFD800 to H'FFEFBF (for the H8S/2635 Group), or H'FFF000 to H'FFFFFF in the chip are directed to the on-chip RAM. ...</p>
20.4 Usage Notes	731	<p>Reserved Areas</p> <p>Description amended</p> <p>Addresses H'FFB000 to H'FFDFFF in the H8S/2636 and H'FFB000 to H'FFD7FF in the H8S/2635 Group are reserved areas that cannot be read or written to. ...</p>
21A.8.1 Boot Mode Figure 21A-9 RAM Area in Boot Mode	758	<p>Figure amended</p>  <p>The diagram shows a vertical stack of memory addresses. On the left, the address H'FFE000 is aligned with the top of a box labeled 'Boot program area (2 kbytes)'. Below this, the address H'FFE7FF is aligned with the top of a second box labeled 'Programming control program area (1.9 kbytes)'. The address H'FFE800 is aligned with the bottom of this second box. At the very bottom of the diagram, the address H'FFEFBF is shown.</p>
	759	<p>Note on Use of Boot Mode</p> <p>Description amended</p> <ul style="list-style-type: none"> • Before branching to the programming control program (RAM area H'FFE800), the chip terminates ...

Item	Page	Revision (See Manual for Details)															
21A.16 Note on Switching from F-ZTAT Version to Mask ROM Version Table 21A-27 Registers Present in F-ZTAT Version but Absent in Mask ROM Version	796	Table 21A-27 amended <table border="1"> <thead> <tr> <th>Register</th> <th>Abbreviation</th> <th>Address</th> </tr> </thead> <tbody> <tr> <td>Flash memory control register 1</td> <td>FLMCR1</td> <td>H'FFA8</td> </tr> <tr> <td>Flash memory control register 2</td> <td>FLMCR2</td> <td>H'FFA9</td> </tr> <tr> <td>Erase block register 1</td> <td>EBR1</td> <td>H'FFAA</td> </tr> <tr> <td>Erase block register 2</td> <td>EBR2</td> <td>H'FFAB</td> </tr> </tbody> </table>	Register	Abbreviation	Address	Flash memory control register 1	FLMCR1	H'FFA8	Flash memory control register 2	FLMCR2	H'FFA9	Erase block register 1	EBR1	H'FFAA	Erase block register 2	EBR2	H'FFAB
Register	Abbreviation	Address															
Flash memory control register 1	FLMCR1	H'FFA8															
Flash memory control register 2	FLMCR2	H'FFA9															
Erase block register 1	EBR1	H'FFAA															
Erase block register 2	EBR2	H'FFAB															
21B.1 Overview	797	Description amended The H8S/2638 and H8S/2639 have 256 kbytes of on-chip flash memory, or 256 kbytes or 384 kbytes of on-chip mask ROM.															
21B.16 Note on Switching from F-ZTAT Version to Mask ROM Version Table 21B-27 Registers Present in F-ZTAT Version but Absent in Mask ROM Version	862	Table 21B-27 amended <table border="1"> <thead> <tr> <th>Register</th> <th>Abbreviation</th> <th>Address</th> </tr> </thead> <tbody> <tr> <td>Flash memory control register 1</td> <td>FLMCR1</td> <td>H'FFA8</td> </tr> <tr> <td>Flash memory control register 2</td> <td>FLMCR2</td> <td>H'FFA9</td> </tr> <tr> <td>Erase block register 1</td> <td>EBR1</td> <td>H'FFAA</td> </tr> <tr> <td>Erase block register 2</td> <td>EBR2</td> <td>H'FFAB</td> </tr> </tbody> </table>	Register	Abbreviation	Address	Flash memory control register 1	FLMCR1	H'FFA8	Flash memory control register 2	FLMCR2	H'FFA9	Erase block register 1	EBR1	H'FFAA	Erase block register 2	EBR2	H'FFAB
Register	Abbreviation	Address															
Flash memory control register 1	FLMCR1	H'FFA8															
Flash memory control register 2	FLMCR2	H'FFA9															
Erase block register 1	EBR1	H'FFAA															
Erase block register 2	EBR2	H'FFAB															
Section 21C ROM (H8S/2635 Group)	863 to 928	Section 21C added															
Section 22B Clock Pulse Generator (H8S/2639 Group, H8S/2635 Group)	941	Section 22B title amended															
22B.3.2 External Clock Input Figure 22B-6 External Clock Input (Examples)	947	Note * added (b) Complementary clock input at XTAL pin* Note: * In the case of the H8S/2635 Group, do not input a complementary clock to the XTAL pin.															

Item	Page	Revision (See Manual for Details)
Section 23A Power- Down Modes [HD64F2636F, HD64F2638F, HD6432636F, HD6432638F, HD64F2630F, HD6432630F, HD64F2635F, HD6432635F, HD6432634F]	951	Section 23A title amended
Section 23B Power- Down Modes [HD64F2636UF, HD6432636UF, HD64F2638UF, HD6432638UF, HD64F2638WF, HD6432638WF, HD64F2639UF, HD6432639UF, HD64F2639WF, HD6432639WF, HD64F2630UF, HD6432630UF, HD64F2630WF, HD6432630WF, HD6432635F, HD64F2635F, HD6432634F]	973	Note added Note: The DTC, PBC, PPB, and D/A converter are not implemented in the H8S/2635 and H8S/2634.

Item	Page	Revision (See Manual for Details)
23B.1 Overview	973	Description amended ... The chip operating modes are as follows: (3) Subactive mode* (U-mask, W-mask version, H8S/2635 Group only) ... (5) Subsleeper mode* (U-mask, W-mask version, H8S/2635 Group only) ... (6) Watch mode* (U-mask, W-mask version, H8S/2635 Group only) ...
	974	Note * amended Note: * Subclock functions (subactive mode, subsleeper mode, and watch mode) are available in the U-mask and W-mask versions, and H8S/2635 Group only. ...
Table 23B-2 LSI Internal States in Each Mode (H8S/2639 Group, H8S/2635 Group)	976	Note *3 added DTC* ³ PBC* ³ PPG* ³ D/A0, 1* ³ Note: 3. The DTC, PBC, PPB, DA0, and DA1 are not implemented in the H8S/2635 and H8S/2634.
23.2.3 Low-Power Control Register (LPWRCR)	983	Note * amended Note: * Bits 7 to 3 in LPWRCR are valid in the U-mask and W-mask versions, and H8S/2635 Group; they are reserved bits in all other versions. ...
23.2.4 Timer Control/Status Register (TCSR)	985	Note * amended Note: 2. Bit 4 (PSS) in TCSR of WDT1 is valid in the U-mask and W-mask versions, and H8S/2635 Group. In versions other than the U-mask and W-mask versions, and H8S/2635 Group, however, the PSS bit ...
	986	Bit 4—Prescaler Select (PSS) Note 2 amended Note: 2. Bit 4 (PSS) in TCSR of WDT1 is valid in the U-mask and W-mask versions, and H8S/2635 Group. In versions other than the U-mask and W-mask versions, and H8S/2635 Group, however, the PSS bit ...

Item **Page** **Revision (See Manual for Details)**

23B.5.1 Module Stop 991
Mode

Note *3 added

Table 23B-5 MSTP
Bits and Corresponding
On-Chip Supporting
Modules

Register	Bit	Module
MSTPCRA	MSTPA6	Data transfer controller (DTC) ^{*3}
	MSTPA5	16-bit timer pulse unit (TPU)
	MSTPA3	Programmable pulse generator (PPG) ^{*3}
MSTPCRC	MSTPA2	D/A converter (channel 0, 1) ^{*3}
	MSTPC4	PC break controller (PBC) ^{*3}
	MSTPC3	HCAN0
	MSTPC2	HCAN1 ^{*3}

Note: 3. The DTC, PPG, D/A converter, PBC, and HCAN1 are not implemented in the H8S/2635 and H8S/2634. MSTPA6, MSTPA3, MSTPA2, MSTPC4, and MSTPC2 are readable/writable bits, but only 1 should be written to them.

23B.5.2 Usage Notes 992

Note added

Note: The DTC is not implemented in the H8S/2635 Group.

23B.6.3 Setting 993
Oscillation Stabilization
Time after Clearing
Software Standby Mode

Using a Crystal Oscillator

Description added

1. Setting for H8S/2636, H8S/2638, H8S/2639, H8S/2630

Set bits STS2 to STS0 so that the standby time is at least 8 ms (the oscillation stabilization time).

Table 23B-6 shows the standby times for different operating frequencies and settings of bits STS2 to STS0.

Table 23B-6 994
Oscillation Stabilization
Time Settings

Table 23B-6 Oscillation Stabilization Time Settings

STS2	STS1	STS0	Standby Time	20 MHz	16 MHz	12 MHz	10 MHz	8 MHz	6 MHz	5 MHz	4 MHz	Unit
0	0	0	8192 states	0.41	0.51	0.68	0.8	1.0	1.3	1.6	2.0	ms
		1	16384 states	0.82	1.0	1.3	1.6	2.0	2.7	3.2	4.1	
	1	0	32768 states	1.6	2.0	2.7	3.3	4.1	5.5	6.5	8.2	
1	0	1	65536 states	3.3	4.1	5.5	6.6	8.2	10.9	13.1	16.4	µs
		1	131072 states	6.6	8.2	10.9	13.1	16.4	21.8	26.2	32.8	
	1	1	262144 states	13.1	16.4	21.8	26.2	32.8	43.6	52.4	65.6	
	1	0	Reserved	—	—	—	—	—	—	—	—	
		1	16 states (Setting prohibited)	0.8	1.0	1.3	1.6	2.0	2.6	3.2	4.0	

: Recommended time setting

Item	Page	Revision (See Manual for Details)																																																																																				
23B.6.3 Setting Oscillation Stabilization Time after Clearing Software Standby Mode	994	2. Setting for H8S/2635, H8S/2634 Set bits STS2 to STS0 so that the standby time is at least 12 ms (the oscillation stabilization time). Table 23B-7 shows the standby times for different operating frequencies and settings of bits STS2 to STS0.																																																																																				

Table 23B-7 Oscillation Stabilization Time Settings																																																																																						
<table border="1"> <caption>Table 23B-7 Oscillation Stabilization Time Settings</caption> <thead> <tr> <th>STS2</th> <th>STS1</th> <th>STS0</th> <th>Standby Time</th> <th>20 MHz</th> <th>16 MHz</th> <th>10 MHz</th> <th>8 MHz</th> <th>5 MHz</th> <th>4 MHz</th> <th>Unit</th> </tr> </thead> <tbody> <tr> <td rowspan="3">0</td> <td rowspan="2">0</td> <td>0</td> <td>8192 states</td> <td>0.41</td> <td>0.51</td> <td>0.8</td> <td>1.0</td> <td>1.6</td> <td>2.0</td> <td rowspan="3">ms</td> </tr> <tr> <td>1</td> <td>16384 states</td> <td>0.82</td> <td>1.0</td> <td>1.6</td> <td>2.0</td> <td>3.2</td> <td>4.1</td> </tr> <tr> <td>1</td> <td>0</td> <td>32768 states</td> <td>1.6</td> <td>2.0</td> <td>3.3</td> <td>4.1</td> <td>6.5</td> <td>8.2</td> </tr> <tr> <td rowspan="5">1</td> <td rowspan="2">0</td> <td>1</td> <td>65536 states</td> <td>3.3</td> <td>4.1</td> <td>6.6</td> <td>8.2</td> <td>13.1</td> <td>16.4</td> </tr> <tr> <td>0</td> <td>131072 states</td> <td>6.6</td> <td>8.2</td> <td>13.1</td> <td>16.4</td> <td>26.2</td> <td>32.8</td> </tr> <tr> <td rowspan="2">1</td> <td>0</td> <td>262144 states</td> <td>13.1</td> <td>16.4</td> <td>26.2</td> <td>32.8</td> <td>52.4</td> <td>65.6</td> </tr> <tr> <td>1</td> <td>Reserved</td> <td>—</td> <td>—</td> <td>—</td> <td>—</td> <td>—</td> <td>—</td> <td>μs</td> </tr> <tr> <td>1</td> <td>16 states (Setting prohibited)</td> <td>0.8</td> <td>1.0</td> <td>1.6</td> <td>2.0</td> <td>3.2</td> <td>4.0</td> <td></td> </tr> </tbody> </table> <p><input type="checkbox"/> Recommended time setting</p>			STS2	STS1	STS0	Standby Time	20 MHz	16 MHz	10 MHz	8 MHz	5 MHz	4 MHz	Unit	0	0	0	8192 states	0.41	0.51	0.8	1.0	1.6	2.0	ms	1	16384 states	0.82	1.0	1.6	2.0	3.2	4.1	1	0	32768 states	1.6	2.0	3.3	4.1	6.5	8.2	1	0	1	65536 states	3.3	4.1	6.6	8.2	13.1	16.4	0	131072 states	6.6	8.2	13.1	16.4	26.2	32.8	1	0	262144 states	13.1	16.4	26.2	32.8	52.4	65.6	1	Reserved	—	—	—	—	—	—	μs	1	16 states (Setting prohibited)	0.8	1.0	1.6	2.0	3.2	4.0	
STS2	STS1	STS0	Standby Time	20 MHz	16 MHz	10 MHz	8 MHz	5 MHz	4 MHz	Unit																																																																												
0	0	0	8192 states	0.41	0.51	0.8	1.0	1.6	2.0	ms																																																																												
		1	16384 states	0.82	1.0	1.6	2.0	3.2	4.1																																																																													
	1	0	32768 states	1.6	2.0	3.3	4.1	6.5	8.2																																																																													
1	0	1	65536 states	3.3	4.1	6.6	8.2	13.1	16.4																																																																													
		0	131072 states	6.6	8.2	13.1	16.4	26.2	32.8																																																																													
	1	0	262144 states	13.1	16.4	26.2	32.8	52.4	65.6																																																																													
		1	Reserved	—	—	—	—	—	—	μs																																																																												
	1	16 states (Setting prohibited)	0.8	1.0	1.6	2.0	3.2	4.0																																																																														

23B.8 Watch Mode (U-mask, W-mask Version, H8S/2635 Group Only)	997	23B.8 title amended																																																																																				

23B.9 Subsleap Mode (U-mask, W-mask Version, H8S/2635 Group Only)	999	23B.9 title amended																																																																																				

23B.10 Subactive Mode (U-mask, W- mask Version, H8S/2635 Group Only)	1000	23B.10 title amended																																																																																				

23B.11 Direct Transitions (U-mask, W-mask Version, H8S/2635 Group Only)	1001	23B.11 title amended																																																																																				

23B.12 φ Clock Output Disabling Function Table 23B-8 φ Pin State in Each Processing State	1002	Note * amended Note: * Subclock functions (subactive mode, subsleap mode, and watch mode) are available in the U-mask and W-mask versions, and H8S/2635 Group only. ...																																																																																				

Item	Page	Revision (See Manual for Details)																					
23B.13 Usage Notes	1003	Description amended 5. (H8S/2639 Group, H8S/2635 Group only) The subclock (ϕ_{SUB}) is ...																					
24.1.4 AC Characteristics Table 24-4 Clock Timing	1012	Symbol of subclock (ϕ_{SUB}) cycle time amended (Before) f_{SUB} → (After) t_{SUB}																					
24.2.4 AC Characteristics Table 24-15 Clock Timing	1029	Symbol of subclock (ϕ_{SUB}) cycle time amended (Before) f_{SUB} → (After) t_{SUB}																					
24.3 H8S/2639 Group, H8S/2635 Group Electrical Characteristics	1038	Note * added Input voltage (XTAL*, EXTAL) Note: * In the case of the H8S/2635 Group, do not input a signal to the XTAL pin.																					
24.3.3 DC Characteristics Table 24-24 DC Characteristics	1040	Table 24-24 amended, notes *7, *8 added HRxD1*7 HTxD1*7 During A/D and D/A*7 conversion																					
<table border="1"> <thead> <tr> <th>Item</th> <th>Symbol</th> <th>Min.</th> <th>Typ.</th> <th>Max.</th> <th>Unit</th> <th>Test Conditions</th> </tr> </thead> <tbody> <tr> <td>Output high voltage</td> <td>PWM1A to PWM1H, PWM2A to PWM2H</td> <td>PWMV_{CC} - 0.5</td> <td>—</td> <td>—</td> <td>—</td> <td>I_{OH} = -15 mA</td> </tr> <tr> <td>Three-state leakage current (off state)</td> <td>Ports 1, 3, A to F, H, J HTxD0, HTxD1*7</td> <td> I_{TSI} </td> <td>—</td> <td>1.0</td> <td>μA</td> <td>V_{in} = 0.5 V to V_{CC} - 0.5 V</td> </tr> </tbody> </table>			Item	Symbol	Min.	Typ.	Max.	Unit	Test Conditions	Output high voltage	PWM1A to PWM1H, PWM2A to PWM2H	PWMV _{CC} - 0.5	—	—	—	I _{OH} = -15 mA	Three-state leakage current (off state)	Ports 1, 3, A to F, H, J HTxD0, HTxD1*7	I _{TSI}	—	1.0	μA	V _{in} = 0.5 V to V _{CC} - 0.5 V
Item	Symbol	Min.	Typ.	Max.	Unit	Test Conditions																	
Output high voltage	PWM1A to PWM1H, PWM2A to PWM2H	PWMV _{CC} - 0.5	—	—	—	I _{OH} = -15 mA																	
Three-state leakage current (off state)	Ports 1, 3, A to F, H, J HTxD0, HTxD1*7	I _{TSI}	—	1.0	μA	V _{in} = 0.5 V to V _{CC} - 0.5 V																	

24.3.3 DC

1042

Table 24-24 amended, notes *7, *8 added

Characteristics

Table 24-24 DC

Characteristics

Item	Symbol	Min.	Typ.	Max.	Unit	Test Conditions	
MOS input pull-up current	Ports A to E $-I_P$	50	—	300	μA	$V_{in} = 0\text{ V}$	
Current dissipation*2 (H8S/2639 Group)	Normal operation	I_{CC}^{*4}	—	75	90	mA	$f = 20\text{ MHz}$
	Sleep mode	—	65	80	—	—	—
	All modules stopped	—	57	—	—	mA	$f = 20\text{ MHz}$ (reference value)
	Medium-speed mode ($\phi/32$)	—	49	—	—	—	—
	Subactive mode	—	0.7	1.0	—	mA	Subclock (using 4.19 MHz crystal oscillator)
	Subsleep mode	—	0.7	1.0	—	—	—
	Watch mode	—	0.6	1.0	—	—	—
	Standby mode*3	—	2.0	5.0	—	μA	$T_a \leq 50^\circ\text{C}$
	—	—	—	—	20	—	$50^\circ\text{C} < T_a$
Current dissipation*2 (H8S/2635 Group)	Normal operation	I_{CC}^{*8}	—	60	65	mA	$f = 20\text{ MHz}$
	Sleep mode	—	50	55	—	—	—
	All modules stopped	—	40	—	—	mA	$f = 20\text{ MHz}$ (reference value)
	Medium-speed mode ($\phi/32$)	—	45	—	—	—	—
	Subactive mode	—	0.35	0.4	—	mA	Subclock (using 5.0 MHz crystal oscillator)
	Subsleep mode	—	0.3	0.35	—	—	—
	Watch mode	—	0.25	0.3	—	—	—
	Standby mode	—	2.0	5.0	—	μA	$T_a \leq 50^\circ\text{C}$
	—	—	—	—	20	—	$50^\circ\text{C} < T_a$

1043

Notes 7, 8 added

Note: 7. The HDxD1, HRxD1 pins, and D/A converter are not available in the H8S/2635 Group.

8. I_{CC} depends on V_{CC} and f as follows:

$$I_{CC}(\text{max.}) = 17(\text{mA}) + 0.43(\text{mA}/(\text{MHz} \times \text{V})) \times V_{CC} \times f (\text{normal operation})$$

$$I_{CC}(\text{max.}) = 17(\text{mA}) + 0.34(\text{mA}/(\text{MHz} \times \text{V})) \times V_{CC} \times f (\text{sleep mode})$$

Item	Page	Revision (See Manual for Details)																																		
24.3.4 AC Characteristics Table 24-27 Clock Timing	1047	Table 24-27 amended																																		
		<table border="1"> <thead> <tr> <th rowspan="2">Item</th> <th rowspan="2">Symbol</th> <th colspan="2">Condition</th> <th rowspan="2">Unit</th> <th rowspan="2">Test Conditions</th> </tr> <tr> <th>Min.</th> <th>Max.</th> </tr> </thead> <tbody> <tr> <td rowspan="2">Clock oscillator settling time in software standby (crystal) (H8S/2639 Group)</td> <td rowspan="2">t_{OSC2}</td> <td>8</td> <td>—</td> <td rowspan="2">ms</td> <td rowspan="2">Figure 23A-3 Figure 23B-3</td> </tr> <tr> <td>12</td> <td>—</td> </tr> <tr> <td>External clock output stabilization delay time</td> <td>t_{DEXT}</td> <td>2</td> <td>—</td> <td>ms</td> <td>Figure 24-10</td> </tr> <tr> <td>Subclock oscillator frequency</td> <td>f_{SUB}</td> <td>31.25</td> <td>39.6</td> <td>kHz</td> <td></td> </tr> <tr> <td>Subclock (ϕ_{SUB}) cycle time</td> <td>t_{SUB}</td> <td>25.6</td> <td>32.0</td> <td>μs</td> <td></td> </tr> </tbody> </table>	Item	Symbol	Condition		Unit	Test Conditions	Min.	Max.	Clock oscillator settling time in software standby (crystal) (H8S/2639 Group)	t_{OSC2}	8	—	ms	Figure 23A-3 Figure 23B-3	12	—	External clock output stabilization delay time	t_{DEXT}	2	—	ms	Figure 24-10	Subclock oscillator frequency	f_{SUB}	31.25	39.6	kHz		Subclock (ϕ_{SUB}) cycle time	t_{SUB}	25.6	32.0	μ s	
Item	Symbol	Condition			Unit	Test Conditions																														
		Min.	Max.																																	
Clock oscillator settling time in software standby (crystal) (H8S/2639 Group)	t_{OSC2}	8	—	ms	Figure 23A-3 Figure 23B-3																															
		12	—																																	
External clock output stabilization delay time	t_{DEXT}	2	—	ms	Figure 24-10																															
Subclock oscillator frequency	f_{SUB}	31.25	39.6	kHz																																
Subclock (ϕ_{SUB}) cycle time	t_{SUB}	25.6	32.0	μ s																																
Table 24-30 Timing of On-Chip Supporting Modules	1050, 1051	Note *1 added PPG*1 HCAN*2 Notes: 1. The PPG output is not available in the H8S/2635 Group. 2. The HCAN input signal is asynchronous. ...																																		
24.3.6 D/A Conversion Characteristics*	1053	Note * added Note: * The D/A conversion is not implemented in the H8S/2635 and H8S/2634.																																		
24.4 H8S/2630 Group Electrical Characteristics	1056 to 1073	“Preliminary” deleted																																		
24.4.3 DC Characteristics Table 24-36 DC Characteristics	1059	Table 24-36 amended																																		
		<table border="1"> <thead> <tr> <th>Item</th> <th>Symbol</th> <th>Min.</th> <th>Typ.</th> <th>Max.</th> <th>Unit</th> <th>Test Conditions</th> </tr> </thead> <tbody> <tr> <td>Output high voltage</td> <td>PWM1A to PWM1H, PWM2A to PWM2H V_{OH}</td> <td>PWMV_{CC} - 0.5</td> <td>—</td> <td>—</td> <td>V</td> <td>$I_{OH} = -15$ mA</td> </tr> <tr> <td>Three-state leakage current (off state)</td> <td>Ports 1, 3, A to F, H, J, HTxD0, HTxD1 I_{TSI}</td> <td>—</td> <td>—</td> <td>1.0</td> <td>μA</td> <td>$V_{in} = 0.5$ V to $V_{CC} - 0.5$ V</td> </tr> </tbody> </table>	Item	Symbol	Min.	Typ.	Max.	Unit	Test Conditions	Output high voltage	PWM1A to PWM1H, PWM2A to PWM2H V_{OH}	PWMV _{CC} - 0.5	—	—	V	$I_{OH} = -15$ mA	Three-state leakage current (off state)	Ports 1, 3, A to F, H, J, HTxD0, HTxD1 $ I_{TSI} $	—	—	1.0	μ A	$V_{in} = 0.5$ V to $V_{CC} - 0.5$ V													
Item	Symbol	Min.	Typ.	Max.	Unit	Test Conditions																														
Output high voltage	PWM1A to PWM1H, PWM2A to PWM2H V_{OH}	PWMV _{CC} - 0.5	—	—	V	$I_{OH} = -15$ mA																														
Three-state leakage current (off state)	Ports 1, 3, A to F, H, J, HTxD0, HTxD1 $ I_{TSI} $	—	—	1.0	μ A	$V_{in} = 0.5$ V to $V_{CC} - 0.5$ V																														
	1060	<table border="1"> <thead> <tr> <th>Item</th> <th>Symbol</th> <th>Min.</th> <th>Typ.</th> <th>Max.</th> <th>Unit</th> <th>Test Conditions</th> </tr> </thead> <tbody> <tr> <td>MOS input pull-up current</td> <td>Ports A to E $-I_P$</td> <td>50</td> <td>—</td> <td>300</td> <td>μA</td> <td>$V_{in} = 0$ V</td> </tr> </tbody> </table>	Item	Symbol	Min.	Typ.	Max.	Unit	Test Conditions	MOS input pull-up current	Ports A to E $-I_P$	50	—	300	μ A	$V_{in} = 0$ V																				
Item	Symbol	Min.	Typ.	Max.	Unit	Test Conditions																														
MOS input pull-up current	Ports A to E $-I_P$	50	—	300	μ A	$V_{in} = 0$ V																														
24.4.4 AC Characteristics Table 24-39 Clock Timing	1065	Symbol of subclock (ϕ_{SUB}) cycle time amended (Before) t_{SUB} → (After) t_{SUB}																																		

Item	Page	Revision (See Manual for Details)																																																																																																																																				
24.5.4 On-Chip Supporting Module Timing Figure 24-20 PPG Output Timing*	1081	Note * added Note: * The PPG output is not implemented in the H8S/2635 and H8S/2634.																																																																																																																																				
A.1 Instruction List Table A-1 Instruction Set	1089	Note *4 added LDM* ⁴ STM* ⁴																																																																																																																																				
	1108	Note: 4. Only register ER0 to ER6 should be used when using the STM/ LDM instruction.																																																																																																																																				
A.2 Instruction Codes Table A-2 Instruction Codes	1117, 1122	Note *3 added LDM* ³ STM* ³																																																																																																																																				
	1123	Note: 3. Only register ER0 to ER6 should be used when using the STM/ LDM instruction.																																																																																																																																				
A.5 Bus States during Instruction Execution Table A-6 Instruction Execution Cycles	1149, 1154	Note *9 added LDM.L (ERn-ERn+1)* ⁹ LDM.L (ERn-ERn+2)* ⁹ LDM.L (ERn-ERn+3)* ⁹ @SP* ⁹																																																																																																																																				
	1155	Note: 9. Only register ER0 to ER6 should be used when using the STM/ LDM instruction.																																																																																																																																				
B.1 Address	1162, 1169 to 1180, 1182, 1183	Note *7 added DTC* ⁷ HCAN1* ⁷ PBC* ⁷ PPG* ⁷ IIC0* ⁴ IIC1* ⁴																																																																																																																																				
		<table border="1"> <thead> <tr> <th colspan="2">Register</th> <th>Bit 7</th> <th>Bit 6</th> <th>Bit 5</th> <th>Bit 4</th> <th>Bit 3</th> <th>Bit 2</th> <th>Bit 1</th> <th>Bit 0</th> <th>Module Name</th> <th>Data Bus Width</th> </tr> </thead> <tbody> <tr> <td>HFFC0</td> <td>IPRA</td> <td>—</td> <td>IPR6</td> <td>IPR5</td> <td>IPR4</td> <td>—</td> <td>IPR2</td> <td>IPR1</td> <td>IPR0</td> <td>INT</td> <td>8</td> </tr> <tr> <td>HFFC1</td> <td>IPRB</td> <td>—</td> <td>IPR6</td> <td>IPR5</td> <td>IPR4</td> <td>—</td> <td>IPR2</td> <td>IPR1</td> <td>IPR0</td> <td>—</td> <td>—</td> </tr> <tr> <td>HFFC2</td> <td>IPRC</td> <td>—</td> <td>—</td> <td>—</td> <td>—</td> <td>—</td> <td>IPR2</td> <td>IPR1</td> <td>IPR0</td> <td>—</td> <td>—</td> </tr> <tr> <td>HFFC3</td> <td>IPRD</td> <td>—</td> <td>IPR6</td> <td>IPR5</td> <td>IPR4</td> <td>—</td> <td>—</td> <td>—</td> <td>—</td> <td>—</td> <td>—</td> </tr> <tr> <td>HFFC4</td> <td>IPRE</td> <td>—</td> <td>IPR6</td> <td>IPR5</td> <td>IPR4</td> <td>—</td> <td>IPR2</td> <td>IPR1</td> <td>IPR0</td> <td>—</td> <td>—</td> </tr> </tbody> </table> <table border="1"> <thead> <tr> <th colspan="2">Register</th> <th>Bit 7</th> <th>Bit 6</th> <th>Bit 5</th> <th>Bit 4</th> <th>Bit 3</th> <th>Bit 2</th> <th>Bit 1</th> <th>Bit 0</th> <th>Module Name</th> <th>Data Bus Width</th> </tr> </thead> <tbody> <tr> <td>HFFA9</td> <td>FLMCR2</td> <td>FLER</td> <td>—</td> <td>—</td> <td>—</td> <td>—</td> <td>—</td> <td>—</td> <td>—</td> <td>FLASH</td> <td>8</td> </tr> <tr> <td>HFFAA</td> <td>EBR1</td> <td>EB7</td> <td>EB6</td> <td>EB5</td> <td>EB4</td> <td>EB3</td> <td>EB2</td> <td>EB1</td> <td>EB0</td> <td>—</td> <td>—</td> </tr> <tr> <td>HFFAB</td> <td>EBR2</td> <td>—</td> <td>—</td> <td>EB13</td> <td>EB12</td> <td>EB11</td> <td>EB10</td> <td>EB9</td> <td>EB8</td> <td>—</td> <td>—</td> </tr> <tr> <td>HFFAC</td> <td>FLPWCR</td> <td>PDWND</td> <td>—</td> <td>—</td> <td>—</td> <td>—</td> <td>—</td> <td>—</td> <td>—</td> <td>—</td> <td>—</td> </tr> </tbody> </table>	Register		Bit 7	Bit 6	Bit 5	Bit 4	Bit 3	Bit 2	Bit 1	Bit 0	Module Name	Data Bus Width	HFFC0	IPRA	—	IPR6	IPR5	IPR4	—	IPR2	IPR1	IPR0	INT	8	HFFC1	IPRB	—	IPR6	IPR5	IPR4	—	IPR2	IPR1	IPR0	—	—	HFFC2	IPRC	—	—	—	—	—	IPR2	IPR1	IPR0	—	—	HFFC3	IPRD	—	IPR6	IPR5	IPR4	—	—	—	—	—	—	HFFC4	IPRE	—	IPR6	IPR5	IPR4	—	IPR2	IPR1	IPR0	—	—	Register		Bit 7	Bit 6	Bit 5	Bit 4	Bit 3	Bit 2	Bit 1	Bit 0	Module Name	Data Bus Width	HFFA9	FLMCR2	FLER	—	—	—	—	—	—	—	FLASH	8	HFFAA	EBR1	EB7	EB6	EB5	EB4	EB3	EB2	EB1	EB0	—	—	HFFAB	EBR2	—	—	EB13	EB12	EB11	EB10	EB9	EB8	—	—	HFFAC	FLPWCR	PDWND	—	—	—	—	—	—	—	—	—
Register		Bit 7	Bit 6	Bit 5	Bit 4	Bit 3	Bit 2	Bit 1	Bit 0	Module Name	Data Bus Width																																																																																																																											
HFFC0	IPRA	—	IPR6	IPR5	IPR4	—	IPR2	IPR1	IPR0	INT	8																																																																																																																											
HFFC1	IPRB	—	IPR6	IPR5	IPR4	—	IPR2	IPR1	IPR0	—	—																																																																																																																											
HFFC2	IPRC	—	—	—	—	—	IPR2	IPR1	IPR0	—	—																																																																																																																											
HFFC3	IPRD	—	IPR6	IPR5	IPR4	—	—	—	—	—	—																																																																																																																											
HFFC4	IPRE	—	IPR6	IPR5	IPR4	—	IPR2	IPR1	IPR0	—	—																																																																																																																											
Register		Bit 7	Bit 6	Bit 5	Bit 4	Bit 3	Bit 2	Bit 1	Bit 0	Module Name	Data Bus Width																																																																																																																											
HFFA9	FLMCR2	FLER	—	—	—	—	—	—	—	FLASH	8																																																																																																																											
HFFAA	EBR1	EB7	EB6	EB5	EB4	EB3	EB2	EB1	EB0	—	—																																																																																																																											
HFFAB	EBR2	—	—	EB13	EB12	EB11	EB10	EB9	EB8	—	—																																																																																																																											
HFFAC	FLPWCR	PDWND	—	—	—	—	—	—	—	—	—																																																																																																																											

Item	Page	Revision (See Manual for Details)																																																																								
B.1 Address	1183	<p>Notes amended</p> <p>Notes: 1. Bit 4 (PSS) in TCSR of WDT1 is valid in the U-mask and W-mask versions, and H8S/2635 Group. In versions other than the U-mask and W-mask versions, and H8S/2635 Group, however, the PSS bit ...</p> <p>2. Subclock functions (subactive mode, subsleep mode, and watch mode) are not available in versions other than the U-mask and W-mask versions, and H8S/2635 Group. Subclock functions may be used with the U-mask and W-mask versions, and H8S/2635 Group.</p> <p>3. Bits DTON, LSON, NESEL, and SUBSTP in LPWRCR are valid in the U-mask and W-mask versions, and H8S/2635 Group. In versions other than the U-mask and W-mask versions, and H8S/2635 Group, however, ...</p> <p>5. This bit is reserved in the H8S/2636.</p> <p>6. This bit is reserved in the H8S/2636 and H8S/2635.</p> <p>7. These bits are not available in the H8S/2635 and H8S/2634.</p> <p>8. These bits are reserved in the H8S/2636, H8S/2638, H8S/2639, and H8S/2635. These bits are valid in the H8S/2630 only.</p>																																																																								
B.2 Functions	1185 to 1201	<p>MRA H'EBC0 DTC* to LAFMH1 H'FA1E HCAN1*</p> <p>Note * added</p> <p>DTC* HCAN1*</p> <p>Note: * This register is not available in the H8S/2635 and H8S/2634.</p>																																																																								
	1200	<p>UMSR0 H'F81A HCAN0, UMSR1 H'FA1A HCAN1*¹</p> <p>Note *² added</p> <table border="1"> <thead> <tr> <th>Bit</th> <th>15</th> <th>14</th> <th>13</th> <th>12</th> <th>11</th> <th>10</th> <th>9</th> <th>8</th> </tr> </thead> <tbody> <tr> <td></td> <td>UMSR7</td> <td>UMSR6</td> <td>UMSR5</td> <td>UMSR4</td> <td>UMSR3</td> <td>UMSR2</td> <td>UMSR1</td> <td>UMSR0</td> </tr> <tr> <td>Initial value</td> <td>0</td> <td>0</td> <td>0</td> <td>0</td> <td>0</td> <td>0</td> <td>0</td> <td>0</td> </tr> <tr> <td>Read/Write</td> <td>R/(W)*²</td> <td>R/(W)*²</td> <td>R/(W)*²</td> <td>R/(W)*²</td> <td>R/(W)*²</td> <td>R/(W)*²</td> <td>R/(W)*²</td> <td>R/(W)*²</td> </tr> </tbody> </table> <table border="1"> <thead> <tr> <th>Bit</th> <th>7</th> <th>6</th> <th>5</th> <th>4</th> <th>3</th> <th>2</th> <th>1</th> <th>0</th> </tr> </thead> <tbody> <tr> <td></td> <td>UMSR15</td> <td>UMSR14</td> <td>UMSR13</td> <td>UMSR12</td> <td>UMSR11</td> <td>UMSR10</td> <td>UMSR9</td> <td>UMSR8</td> </tr> <tr> <td>Initial value</td> <td>0</td> <td>0</td> <td>0</td> <td>0</td> <td>0</td> <td>0</td> <td>0</td> <td>0</td> </tr> <tr> <td>Read/Write</td> <td>R/(W)*²</td> <td>R/(W)*²</td> <td>R/(W)*²</td> <td>R/(W)*²</td> <td>R/(W)*²</td> <td>R/(W)*²</td> <td>R/(W)*²</td> <td>R/(W)*²</td> </tr> </tbody> </table> <p>Notes: 1. This register is not available in the H8S/2635 and H8S/2634</p> <p>2. Only 1 can be written, to clear the flag to 0.</p>	Bit	15	14	13	12	11	10	9	8		UMSR7	UMSR6	UMSR5	UMSR4	UMSR3	UMSR2	UMSR1	UMSR0	Initial value	0	0	0	0	0	0	0	0	Read/Write	R/(W)* ²	R/(W)* ²	R/(W)* ²	R/(W)* ²	R/(W)* ²	R/(W)* ²	R/(W)* ²	R/(W)* ²	Bit	7	6	5	4	3	2	1	0		UMSR15	UMSR14	UMSR13	UMSR12	UMSR11	UMSR10	UMSR9	UMSR8	Initial value	0	0	0	0	0	0	0	0	Read/Write	R/(W)* ²	R/(W)* ²	R/(W)* ²	R/(W)* ²	R/(W)* ²	R/(W)* ²	R/(W)* ²	R/(W)* ²
Bit	15	14	13	12	11	10	9	8																																																																		
	UMSR7	UMSR6	UMSR5	UMSR4	UMSR3	UMSR2	UMSR1	UMSR0																																																																		
Initial value	0	0	0	0	0	0	0	0																																																																		
Read/Write	R/(W)* ²	R/(W)* ²	R/(W)* ²	R/(W)* ²	R/(W)* ²	R/(W)* ²	R/(W)* ²	R/(W)* ²																																																																		
Bit	7	6	5	4	3	2	1	0																																																																		
	UMSR15	UMSR14	UMSR13	UMSR12	UMSR11	UMSR10	UMSR9	UMSR8																																																																		
Initial value	0	0	0	0	0	0	0	0																																																																		
Read/Write	R/(W)* ²	R/(W)* ²	R/(W)* ²	R/(W)* ²	R/(W)* ²	R/(W)* ²	R/(W)* ²	R/(W)* ²																																																																		

Item	Page	Revision (See Manual for Details)
B.2 Functions	1266 to 1329	MC0[1] H'FA20 HCAN1 to MD15[8] H'FB2F HCAN1 Note added Note: These registers are not available in the H8S/2635 and H8S/2634.
	1341	SCKCR H'FDE6 System Note * amended Note: * Subclock functions (subactive mode, subsleep mode, and watch mode) are available in the U-mask and W-mask versions, and H8S/2635 Group only. ...
	1344	LPWRCCR H'FDEC System Note * amended Note: * Bits in 7 to 3 in LPWRCCR are valid in the U-mask and W-mask versions, and H8S/2635 Group; they are reserved bits in all other versions. ...
	1345	BARA H'FE00 PBC, BARB H'FE04 PBC Note 2 added Notes: 1. The bit configuration of BARB is the same as for BARA. 2. These registers are not available in the H8S/2635 and H8S/2634.
	1346	BCRA H'FE08 PBC, BCRB H'FE09 PBC Note 2 added Notes: 1. The bit configuration of BCRB is the same as for BCRA. 2. These registers are not available in the H8S/2635 and H8S/2634.
1349 to 1356	DTCERA H'FE16 DTC to DTVECR H'FE1F DTC, PCR H'FE26 PPG to NDRL H'FE2F PPG Note added Note: This register is not available in the H8S/2635 and H8S/2634.	

B.2 Functions 1360 P3ODR H'FE46 Port

Figure amended

Bit	7	6	5	4	3	2	1	0
	—	—	P35ODR	P34ODR	P33ODR	P32ODR	P31ODR	P30ODR
Initial value	Undefined	Undefined	0	0	0	0	0	0
Read/Write	—	—	R/W	R/W	R/W	R/W	R/W	R/W

PAODR H'FE47 Port

Figure amended

Bit	7	6	5	4	3	2	1	0
	—	—	—	—	PA3ODR	PA2ODR	PA1ODR	PA0ODR
Initial value	Undefined	Undefined	Undefined	Undefined	0	0	0	0
Read/Write	—	—	—	—	R/W	R/W	R/W	R/W

1361 PBODR H'FE48 Port

Figure amended

Bit	7	6	5	4	3	2	1	0
	PB7ODR	PB6ODR	PB5ODR	PB4ODR	PB3ODR	PB2ODR	PB1ODR	PB0ODR
Initial value	0	0	0	0	0	0	0	0
Read/Write	R/W	R/W	R/W	R/W	R/W	R/W	R/W	R/W

PCODR H'FE49 Port

Figure amended

Bit	7	6	5	4	3	2	1	0
	PC7ODR	PC6ODR	PC5ODR	PC4ODR	PC3ODR	PC2ODR	PC1ODR	PC0ODR
Initial value	0	0	0	0	0	0	0	0
Read/Write	R/W	R/W	R/W	R/W	R/W	R/W	R/W	R/W

1382 IPRA H'FEC0 INT to IPRM H'FECC INT

Note *3 added

DTC*³ PC break*³ HCAN channel 1*³

Note: 3. The DTC, PC break, and HCAN are not implemented in the H8S/2635 and H8S/2634.

1387 BCRL H'FED5 Bus Controller

Figure amended

	2	1	0
	—	WDBE	—
	0	0	0
	R/W	R/W	R/W

Figure amended

Bit	7	6	5	4	3	2	1	0
	—	—	—	—	RAMS	RAM2	RAM1	RAM0
Initial value	0	0	0	0	0	0	0	0
Read/Write	R	R	R/W	R/W	R/W	R/W	R/W	R/W

Flash Memory Area Selection

• H8S/2636

Addresses	Block Name	RAMS	RAM2	RAM1	RAM0
H'FFE000–H'FFE3FF	RAM area 1 kB	0	*	*	*
H'000000–H'0003FF	EB0 (1 kB)	1	0	0	1
H'000400–H'0007FF	EB1 (1 kB)			1	
H'000800–H'000BFF	EB2 (1 kB)		1	0	
H'000C00–H'000FFF	EB3 (1 kB)			1	

*: Don't care

• H8S/2638, H8S/2639, H8S/2630

Addresses	Block Name	RAMS	RAM2	RAM1	RAM0	
H'FFD000–H'FFDFFF	RAM area 4 kB	0	*	*	*	
H'000000–H'000FFF	EB0 (4 kB)	1	0	0	0	
H'001000–H'001FFF	EB1 (4 kB)			1		
H'002000–H'002FFF	EB2 (4 kB)			0		
H'003000–H'003FFF	EB3 (4 kB)		1	0	1	1
H'004000–H'004FFF	EB4 (4 kB)				0	
H'005000–H'005FFF	EB5 (4 kB)			1		
H'006000–H'006FFF	EB6 (4 kB)			0		
H'007000–H'007FFF	EB7 (4 kB)	1				

*: Don't care

• H8S/2635

Addresses	Block Name	RAMS	RAM2	RAM1	RAM0	
H'FFD800–H'FFE7FF	RAM area 4 kB	0	*	*	*	
H'000000–H'000FFF	EB0 (4 kB)	1	0	0	0	
H'001000–H'001FFF	EB1 (4 kB)			1		
H'002000–H'002FFF	EB2 (4 kB)			0		
H'003000–H'003FFF	EB3 (4 kB)		1	0	1	1
H'004000–H'004FFF	EB4 (4 kB)				0	
H'005000–H'005FFF	EB5 (4 kB)			1		
H'006000–H'006FFF	EB6 (4 kB)			0		
H'007000–H'007FFF	EB7 (4 kB)	1				

*: Don't care

RAM Select

0	Emulation not selected Program/erase-protection of all flash memory blocks is disabled
1	Emulation selected Program/erase-protection of all flash memory blocks is enabled

Figure amended

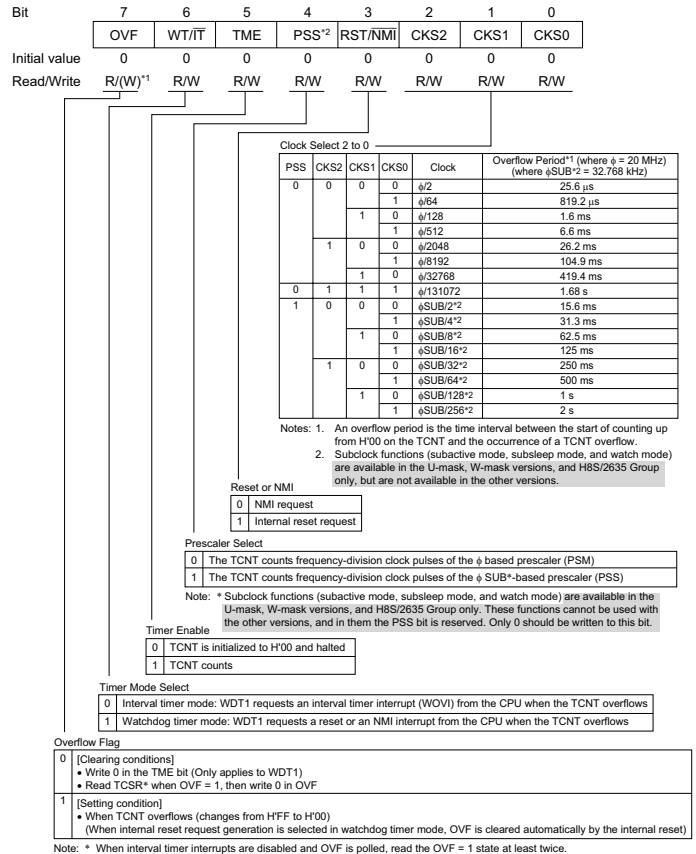

Notes: TCSR1 register differs from other registers in being more difficult to write to. For details see section 12.2.4, Notes on Register Access.

- Only 0 can be written, to clear the flag.
- Subclock functions (subactive mode, subsleep mode, and watch mode) are available in the U-mask, W-mask versions, and H8S/2635 Group only.

Note added

Note: These registers are not available in the H8S/2635 and H8S/2634.

Note added

Note: This register is not available in the H8S/2635 and H8S/2634.

1443 EBR1 H'FFAA Flash Memory, EBR2 H'FFAB Flash Memory
Figure amended

EBR1

Bit	15	14	13	12	11	10	9	8
	EB7	EB6	EB5	EB4	EB3	EB2	EB1	EB0
Initial value	0	0	0	0	0	0	0	0
Read/Write	R/W	R/W	R/W	R/W	R/W	R/W	R/W	R/W

EBR2

Bit	7	6	5	4	3	2	1	0
	—	—	EB13*3	EB12*3	EB11*2	EB10*1	EB9	EB8
Initial value	0	0	0	0	0	0	0	0
Read/Write	R/W	R/W	R/W	R/W	R/W	R/W	R/W	R/W

Specify the flash memory erase area

• H8S/2636

Block (Size)	Addresses
EB0 (1 kbyte)	H'000000 to H'0003FF
EB1 (1 kbyte)	H'000400 to H'0007FF
EB2 (1 kbyte)	H'000800 to H'000BFF
EB3 (1 kbyte)	H'000C00 to H'000FFF
EB4 (28 kbytes)	H'001000 to H'007FFF
EB5 (16 kbytes)	H'008000 to H'00BFFF
EB6 (8 kbytes)	H'00C000 to H'00DFFF
EB7 (8 kbytes)	H'00E000 to H'00FFFF
EB8 (32 kbytes)	H'010000 to H'017FFF
EB9 (32 kbytes)	H'018000 to H'01FFFF

• H8S/2638, H8S/2639

Block (Size)	Addresses
EB0 (4 kbytes)	H'000000 to H'000FFF
EB1 (4 kbytes)	H'001000 to H'001FFF
EB2 (4 kbytes)	H'002000 to H'002FFF
EB3 (4 kbytes)	H'003000 to H'003FFF
EB4 (4 kbytes)	H'004000 to H'004FFF
EB5 (4 kbytes)	H'005000 to H'005FFF
EB6 (4 kbytes)	H'006000 to H'006FFF
EB7 (4 kbytes)	H'007000 to H'007FFF
EB8 (32 kbytes)	H'008000 to H'00FFFF
EB9 (64 kbytes)	H'010000 to H'01FFFF
EB10 (64 kbytes)	H'020000 to H'02FFFF
EB11 (64 kbytes)	H'030000 to H'03FFFF

• H8S/2635

Block (Size)	Addresses
EB0 (4 kbytes)	H'000000 to H'000FFF
EB1 (4 kbytes)	H'001000 to H'001FFF
EB2 (4 kbytes)	H'002000 to H'002FFF
EB3 (4 kbytes)	H'003000 to H'003FFF
EB4 (4 kbytes)	H'004000 to H'004FFF
EB5 (4 kbytes)	H'005000 to H'005FFF
EB6 (4 kbytes)	H'006000 to H'006FFF
EB7 (4 kbytes)	H'007000 to H'007FFF
EB8 (32 kbytes)	H'008000 to H'00FFFF
EB9 (64 kbytes)	H'010000 to H'01FFFF
EB10 (64 kbytes)	H'020000 to H'02FFFF

• H8S/2630

Block (Size)	Addresses
EB0 (4 kbytes)	H'000000 to H'000FFF
EB1 (4 kbytes)	H'001000 to H'001FFF
EB2 (4 kbytes)	H'002000 to H'002FFF
EB3 (4 kbytes)	H'003000 to H'003FFF
EB4 (4 kbytes)	H'004000 to H'004FFF
EB5 (4 kbytes)	H'005000 to H'005FFF
EB6 (4 kbytes)	H'006000 to H'006FFF
EB7 (4 kbytes)	H'007000 to H'007FFF
EB8 (32 kbytes)	H'008000 to H'00FFFF
EB9 (64 kbytes)	H'010000 to H'01FFFF
EB10 (64 kbytes)	H'020000 to H'02FFFF
EB11 (64 kbytes)	H'030000 to H'03FFFF
EB12 (64 kbytes)	H'040000 to H'04FFFF
EB13 (64 kbytes)	H'050000 to H'05FFFF

Notes: 1. On the H8S/2636, these bits are reserved.
 2. Reserved in the H8S/2636 and H8S/2635.
 3. Reserved in the H8S/2638, H8S/2639, and H8S/2635.

Item	Page	Revision (See Manual for Details)																
C.1 Port 1 Block Diagrams Figure C-1 (a) Port 1 Block Diagram (Pins P10 and P11) to Figure C-1 (f) Port 1 Block Diagram (Pin P17)	1448 to 1453	Note *2 added PPG module*2 Notes: 1. Priority order: ... 2. The PPG module is not implemented in the H8S/2635 and H8S/2634.																
C.3 Port 4 Block Diagram Figure C-3 (b) Port 4 Block Diagram (Pins P46, P47)	1460	Note * added D/A converter module* Notes: The D/A converter is not implemented in the H8S/2635 and H8S/2634. n = 6, 7																
D.1 Port States in Each Mode Table D-1 I/O Port States in Each Processing State	1479, 1480	Table D-1 amended <table border="1"> <thead> <tr> <th>Port Name</th> <th>Pin Name</th> </tr> </thead> <tbody> <tr> <td>PF6/AS</td> <td></td> </tr> <tr> <td>PF5/RD</td> <td></td> </tr> <tr> <td>PF4/HWR</td> <td></td> </tr> <tr> <td> </td> <td> </td> </tr> <tr> <td> </td> <td> </td> </tr> <tr> <th>Port Name</th> <th>Pin Name</th> </tr> <tr> <td>PF3/LWR</td> <td></td> </tr> </tbody> </table>	Port Name	Pin Name	PF6/AS		PF5/RD		PF4/HWR						Port Name	Pin Name	PF3/LWR	
Port Name	Pin Name																	
PF6/AS																		
PF5/RD																		
PF4/HWR																		
Port Name	Pin Name																	
PF3/LWR																		

Item **Page** **Revision (See Manual for Details)**

F. Product Code 1483 Table F-1 amended
Lineup

Table F-1 H8S/2636,
H8S/2638, H8S/2639,
and H8S/2630 Product
Code Lineup

Product Type	Product Code	Mark Code	Functions	Packages	
H8S/2630 F-ZTAT version	HD64F2630	HD64F2630F	No subclock function or I ² C bus interface	128-pin QFP (FP-128B)	
		HD64F2630UF	Subclock function, no I ² C bus interface	128-pin QFP (FP-128B)	
		HD64F2630WF	Subclock function and I ² C bus interface	128-pin QFP (FP-128B)	
	Mask ROM version	HD6432630	HD6432630F	No subclock function or I ² C bus interface	128-pin QFP (FP-128B)
			HD6432630UF	Subclock function, no I ² C bus interface	128-pin QFP (FP-128B)
			HD6432630WF	Subclock function and I ² C bus interface	128-pin QFP (FP-128B)
H8S/2635 F-ZTAT version	HD64F2635	HD64F2635F	Subclock function, no I ² C bus interface	128-pin QFP (FP-128B)	
		Mask ROM version	HD6432635*	Subclock function, no I ² C bus interface	128-pin QFP (FP-128B)
			HD6432634*	Subclock function, no I ² C bus interface	128-pin QFP (FP-128B)

Note: * Under development

G Package 1484 Figure G-1 replaced
Dimensions

Figure G-1 FP-128B
Package Dimensions

Contents

Section 1	Overview.....	1
1.1	Overview.....	1
1.2	Internal Block Diagram.....	6
1.3	Pin Description	9
1.3.1	Pin Arrangement.....	9
1.3.2	Pin Functions in Each Operating Mode.....	13
1.3.3	Pin Functions	18
1.4	Differences between H8S/2636, H8S/2638, H8S/2639, H8S/2630, H8S/2635, and H8S/2634.....	23
Section 2	CPU	25
2.1	Overview.....	25
2.1.1	Features.....	25
2.1.2	Differences between H8S/2600 CPU and H8S/2000 CPU	26
2.1.3	Differences from H8/300 CPU	27
2.1.4	Differences from H8/300H CPU	28
2.2	CPU Operating Modes.....	28
2.3	Address Space.....	33
2.4	Register Configuration.....	34
2.4.1	Overview.....	34
2.4.2	General Registers.....	35
2.4.3	Control Registers	36
2.4.4	Initial Register Values	38
2.5	Data Formats.....	39
2.5.1	General Register Data Formats.....	39
2.5.2	Memory Data Formats.....	41
2.6	Instruction Set.....	42
2.6.1	Overview.....	42
2.6.2	Instructions and Addressing Modes.....	43
2.6.3	Table of Instructions Classified by Function	45
2.6.4	Basic Instruction Formats	54
2.7	Addressing Modes and Effective Address Calculation.....	56
2.7.1	Addressing Mode.....	56
2.7.2	Effective Address Calculation	59
2.8	Processing States	63
2.8.1	Overview.....	63
2.8.2	Reset State	64

2.8.3	Exception-Handling State	65
2.8.4	Program Execution State	68
2.8.5	Bus-Released State	68
2.8.6	Power-Down State	68
2.9	Basic Timing	69
2.9.1	Overview	69
2.9.2	On-Chip Memory (ROM, RAM)	69
2.9.3	On-Chip Supporting Module Access Timing	71
2.9.4	On-Chip HCAN Module Access Timing	73
2.9.5	Port H and J Register Access Timing	75
2.9.6	External Address Space Access Timing	76
2.10	Usage Note	77
2.10.1	TAS Instruction	77
2.10.2	STM/LDM Instructions	77
2.10.3	Caution to Observe when Using Bit Manipulation Instructions	77
Section 3 MCU Operating Modes		79
3.1	Overview	79
3.1.1	Operating Mode Selection	79
3.1.2	Register Configuration	80
3.2	Register Descriptions	80
3.2.1	Mode Control Register (MDCR)	80
3.2.2	System Control Register (SYSCR)	81
3.2.3	Pin Function Control Register (PFCR)	83
3.3	Operating Mode Descriptions	85
3.3.1	Mode 4	85
3.3.2	Mode 5	85
3.3.3	Mode 6	85
3.3.4	Mode 7	86
3.4	Pin Functions in Each Operating Mode	86
3.5	Address Map in Each Operating Mode	87
Section 4 Exception Handling		93
4.1	Overview	93
4.1.1	Exception Handling Types and Priority	93
4.1.2	Exception Handling Operation	94
4.1.3	Exception Vector Table	94
4.2	Reset	96
4.2.1	Overview	96
4.2.2	Reset Sequence	96

4.2.3	Interrupts after Reset.....	98
4.2.4	State of On-Chip Supporting Modules after Reset Release	99
4.3	Traces.....	99
4.4	Interrupts.....	100
4.5	Trap Instruction	101
4.6	Stack Status after Exception Handling.....	102
4.7	Notes on Use of the Stack.....	103
Section 5 Interrupt Controller		105
5.1	Overview.....	105
5.1.1	Features.....	105
5.1.2	Block Diagram.....	106
5.1.3	Pin Configuration	107
5.1.4	Register Configuration.....	107
5.2	Register Descriptions.....	108
5.2.1	System Control Register (SYSCR).....	108
5.2.2	Interrupt Priority Registers A to H, J to M (IPRA to IPRH, IPRJ to IPRM)	109
5.2.3	IRQ Enable Register (IER).....	110
5.2.4	IRQ Sense Control Registers H and L (ISCRH, ISCRL).....	111
5.2.5	IRQ Status Register (ISR).....	112
5.3	Interrupt Sources.....	114
5.3.1	External Interrupts	114
5.3.2	Internal Interrupts	116
5.3.3	Interrupt Exception Handling Vector Table.....	116
5.4	Interrupt Operation	120
5.4.1	Interrupt Control Modes and Interrupt Operation.....	120
5.4.2	Interrupt Control Mode 0.....	124
5.4.3	Interrupt Control Mode 2.....	126
5.4.4	Interrupt Exception Handling Sequence	128
5.4.5	Interrupt Response Times	129
5.5	Usage Notes	130
5.5.1	Contention between Interrupt Generation and Disabling.....	130
5.5.2	Instructions that Disable Interrupts.....	131
5.5.3	Times when Interrupts Are Disabled	131
5.5.4	Interrupts during Execution of EEPMOV Instruction	132
5.5.5	IRQ Interrupts.....	132
5.5.6	Notes on Use of NMI Interrupt.....	132
5.6	DTC Activation by Interrupt.....	133
5.6.1	Overview.....	133
5.6.2	Block Diagram.....	133

5.6.3	Operation	134
Section 6 PC Break Controller (PBC).....		137
6.1	Overview.....	137
6.1.1	Features.....	137
6.1.2	Block Diagram.....	138
6.1.3	Register Configuration.....	139
6.2	Register Descriptions.....	139
6.2.1	Break Address Register A (BARA)	139
6.2.2	Break Address Register B (BARB)	140
6.2.3	Break Control Register A (BCRA)	140
6.2.4	Break Control Register B (BCRB)	142
6.2.5	Module Stop Control Register C (MSTPCRC)	142
6.3	Operation	143
6.3.1	PC Break Interrupt Due to Instruction Fetch	143
6.3.2	PC Break Interrupt Due to Data Access	144
6.3.3	Notes on PC Break Interrupt Handling	144
6.3.4	Operation in Transitions to Power-Down Modes	145
6.3.5	PC Break Operation in Continuous Data Transfer.....	146
6.3.6	When Instruction Execution Is Delayed by One State.....	147
6.3.7	Additional Notes.....	148
Section 7 Bus Controller		149
7.1	Overview.....	149
7.1.1	Features.....	149
7.1.2	Block Diagram.....	150
7.1.3	Pin Configuration	151
7.1.4	Register Configuration.....	151
7.2	Register Descriptions.....	152
7.2.1	Bus Width Control Register (ABWCR).....	152
7.2.2	Access State Control Register (ASTCR)	153
7.2.3	Wait Control Registers H and L (WCRH, WCRL).....	154
7.2.4	Bus Control Register H (BCRH)	158
7.2.5	Bus Control Register L (BCRL)	160
7.2.6	Pin Function Control Register (PFCR)	161
7.3	Overview of Bus Control.....	163
7.3.1	Area Partitioning.....	163
7.3.2	Bus Specifications	164
7.3.3	Memory Interfaces.....	165
7.3.4	Interface Specifications for Each Area	166

7.4	Basic Bus Interface	167
7.4.1	Overview.....	167
7.4.2	Data Size and Data Alignment.....	167
7.4.3	Valid Strobes	169
7.4.4	Basic Timing.....	170
7.4.5	Wait Control	178
7.5	Burst ROM Interface	179
7.5.1	Overview.....	179
7.5.2	Basic Timing.....	179
7.5.3	Wait Control	181
7.6	Idle Cycle.....	181
7.6.1	Operation	181
7.6.2	Pin States During Idle Cycles	185
7.7	Write Data Buffer Function	186
7.8	Bus Arbitration	187
7.8.1	Overview.....	187
7.8.2	Operation	187
7.8.3	Bus Transfer Timing.....	187
7.9	Resets and the Bus Controller.....	188
Section 8 Data Transfer Controller (DTC).....		189
8.1	Overview.....	189
8.1.1	Features.....	189
8.1.2	Block Diagram.....	190
8.1.3	Register Configuration.....	191
8.2	Register Descriptions.....	192
8.2.1	DTC Mode Register A (MRA)	192
8.2.2	DTC Mode Register B (MRB).....	194
8.2.3	DTC Source Address Register (SAR).....	195
8.2.4	DTC Destination Address Register (DAR).....	195
8.2.5	DTC Transfer Count Register A (CRA)	195
8.2.6	DTC Transfer Count Register B (CRB).....	196
8.2.7	DTC Enable Registers (DTCER).....	196
8.2.8	DTC Vector Register (DTVECR).....	197
8.2.9	Module Stop Control Register A (MSTPCRA)	199
8.3	Operation	200
8.3.1	Overview.....	200
8.3.2	Activation Sources.....	202
8.3.3	DTC Vector Table	204
8.3.4	Location of Register Information in Address Space.....	208

8.3.5	Normal Mode.....	209
8.3.6	Repeat Mode.....	210
8.3.7	Block Transfer Mode.....	211
8.3.8	Chain Transfer.....	213
8.3.9	Operation Timing.....	214
8.3.10	Number of DTC Execution States.....	215
8.3.11	Procedures for Using DTC.....	217
8.3.12	Examples of Use of the DTC.....	218
8.4	Interrupts.....	221
8.5	Usage Notes.....	221
Section 9 I/O Ports.....		223
9.1	Overview.....	223
9.2	Port 1.....	227
9.2.1	Overview.....	227
9.2.2	Register Configuration.....	228
9.2.3	Pin Functions.....	229
9.3	Port 3.....	242
9.3.1	Overview.....	242
9.3.2	Register Configuration.....	243
9.3.3	Pin Functions.....	245
9.4	Port 4.....	248
9.4.1	Overview.....	248
9.4.2	Register Configuration.....	249
9.4.3	Pin Functions.....	249
9.5	Port 9.....	250
9.5.1	Overview.....	250
9.5.2	Register Configuration.....	251
9.5.3	Pin Functions.....	251
9.6	Port A.....	252
9.6.1	Overview.....	252
9.6.2	Register Configuration.....	253
9.6.3	Pin Functions.....	256
9.6.4	Pin Functions.....	258
9.6.5	MOS Input Pull-Up Function.....	259
9.7	Port B.....	260
9.7.1	Overview.....	260
9.7.2	Register Configuration.....	261
9.7.3	Pin Functions.....	264
9.7.4	MOS Input Pull-Up Function.....	265

9.8	Port C.....	266
9.8.1	Overview.....	266
9.8.2	Register Configuration.....	267
9.8.3	Pin Functions for Each Mode	270
9.8.4	MOS Input Pull-Up Function	272
9.9	Port D.....	273
9.9.1	Overview.....	273
9.9.2	Register Configuration.....	274
9.9.3	Pin Functions	276
9.9.4	MOS Input Pull-Up Function	277
9.10	Port E.....	278
9.10.1	Overview.....	278
9.10.2	Register Configuration.....	279
9.10.3	Pin Functions	281
9.10.4	MOS Input Pull-Up Function	283
9.11	Port F.....	284
9.11.1	Overview.....	284
9.11.2	Register Configuration.....	285
9.11.3	Pin Functions	287
9.12	Port H.....	289
9.12.1	Overview.....	289
9.12.2	Register Configuration.....	290
9.12.3	Pin Functions	291
9.13	Port J.....	292
9.13.1	Overview.....	292
9.13.2	Register Configuration.....	293
9.13.3	Pin Functions	294
Section 10 16-Bit Timer Pulse Unit (TPU).....		295
10.1	Overview.....	295
10.1.1	Features.....	295
10.1.2	Block Diagram.....	299
10.1.3	Pin Configuration	300
10.1.4	Register Configuration.....	302
10.2	Register Descriptions.....	304
10.2.1	Timer Control Register (TCR).....	304
10.2.2	Timer Mode Register (TMDR).....	309
10.2.3	Timer I/O Control Register (TIOR).....	311
10.2.4	Timer Interrupt Enable Register (TIER).....	325
10.2.5	Timer Status Register (TSR).....	328

10.2.6	Timer Counter (TCNT).....	332
10.2.7	Timer General Register (TGR)	333
10.2.8	Timer Start Register (TSTR)	334
10.2.9	Timer Synchro Register (TSYR)	335
10.2.10	Module Stop Control Register A (MSTPCRA)	336
10.3	Interface to Bus Master.....	337
10.3.1	16-Bit Registers	337
10.3.2	8-Bit Registers	337
10.4	Operation	339
10.4.1	Overview.....	339
10.4.2	Basic Functions.....	340
10.4.3	Synchronous Operation	346
10.4.4	Buffer Operation.....	348
10.4.5	Cascaded Operation.....	352
10.4.6	PWM Modes.....	354
10.4.7	Phase Counting Mode.....	360
10.5	Interrupts.....	367
10.5.1	Interrupt Sources and Priorities	367
10.5.2	DTC Activation	369
10.5.3	A/D Converter Activation.....	369
10.6	Operation Timing.....	370
10.6.1	Input/Output Timing.....	370
10.6.2	Interrupt Signal Timing	374
10.7	Usage Notes.....	378
Section 11 Programmable Pulse Generator (PPG)		389
11.1	Overview.....	389
11.1.1	Features.....	389
11.1.2	Block Diagram.....	390
11.1.3	Pin Configuration	391
11.1.4	Registers	392
11.2	Register Descriptions.....	393
11.2.1	Next Data Enable Registers H and L (NDERH, NDERL).....	393
11.2.2	Output Data Registers H and L (PODRH, PODRL).....	394
11.2.3	Next Data Registers H and L (NDRH, NDRL).....	395
11.2.4	Notes on NDR Access	395
11.2.5	PPG Output Control Register (PCR)	397
11.2.6	PPG Output Mode Register (PMR)	399
11.2.7	Port 1 Data Direction Register (P1DDR).....	402
11.2.8	Module Stop Control Register A (MSTPCRA)	402

11.3	Operation	403
11.3.1	Overview.....	403
11.3.2	Output Timing	404
11.3.3	Normal Pulse Output	405
11.3.4	Non-Overlapping Pulse Output	407
11.3.5	Inverted Pulse Output	410
11.3.6	Pulse Output Triggered by Input Capture	411
11.4	Usage Notes	412
Section 12 Watchdog Timer.....		415
12.1	Overview.....	415
12.1.1	Features.....	415
12.1.2	Block Diagram.....	416
12.1.3	Pin Configuration	418
12.1.4	Register Configuration.....	418
12.2	Register Descriptions	419
12.2.1	Timer Counter (TCNT).....	419
12.2.2	Timer Control/Status Register (TCSR).....	420
12.2.3	Reset Control/Status Register (RSTCSR).....	426
12.2.4	Notes on Register Access	427
12.3	Operation	429
12.3.1	Watchdog Timer Operation	429
12.3.2	Interval Timer Operation	431
12.3.3	Timing of Setting Overflow Flag (OVF)	431
12.3.4	Timing of Setting of Watchdog Timer Overflow Flag (WOVF)	432
12.4	Interrupts.....	433
12.5	Usage Notes	433
12.5.1	Contention between Timer Counter (TCNT) Write and Increment	433
12.5.2	Changing Value of PSS and CKS2 to CKS0	434
12.5.3	Switching between Watchdog Timer Mode and Interval Timer Mode.....	434
12.5.4	Internal Reset in Watchdog Timer Mode.....	434
12.5.5	OVF Flag Clearing in Interval Timer Mode	434
Section 13 Serial Communication Interface (SCI)		435
13.1	Overview.....	435
13.1.1	Features.....	435
13.1.2	Block Diagram.....	437
13.1.3	Pin Configuration	438
13.1.4	Register Configuration.....	439
13.2	Register Descriptions	440

13.2.1	Receive Shift Register (RSR)	440
13.2.2	Receive Data Register (RDR).....	440
13.2.3	Transmit Shift Register (TSR).....	441
13.2.4	Transmit Data Register (TDR)	441
13.2.5	Serial Mode Register (SMR)	442
13.2.6	Serial Control Register (SCR)	445
13.2.7	Serial Status Register (SSR)	449
13.2.8	Bit Rate Register (BRR)	453
13.2.9	Smart Card Mode Register (SCMR).....	460
13.2.10	Module Stop Control Register B (MSTPCRB)	461
13.3	Operation	463
13.3.1	Overview.....	463
13.3.2	Operation in Asynchronous Mode	465
13.3.3	Multiprocessor Communication Function	476
13.3.4	Operation in Clocked Synchronous Mode	484
13.4	SCI Interrupts.....	493
13.5	Usage Notes	494
 Section 14 Smart Card Interface		503
14.1	Overview.....	503
14.1.1	Features.....	503
14.1.2	Block Diagram.....	504
14.1.3	Pin Configuration	505
14.1.4	Register Configuration.....	506
14.2	Register Descriptions.....	507
14.2.1	Smart Card Mode Register (SCMR).....	507
14.2.2	Serial Status Register (SSR)	509
14.2.3	Serial Mode Register (SMR)	511
14.2.4	Serial Control Register (SCR)	513
14.3	Operation	514
14.3.1	Overview.....	514
14.3.2	Pin Connections	514
14.3.3	Data Format	516
14.3.4	Register Settings	518
14.3.5	Clock.....	520
14.3.6	Data Transfer Operations.....	522
14.3.7	Operation in GSM Mode	529
14.3.8	Operation in Block Transfer Mode	530
14.4	Usage Notes	531

Section 15	I ² C Bus Interface [Option] (Only for the H8S/2638, H8S/2639, and H8S/2630).....	535
15.1	Overview.....	535
15.1.1	Features.....	535
15.1.2	Block Diagram.....	536
15.1.3	Input/Output Pins.....	538
15.1.4	Register Configuration.....	539
15.2	Register Descriptions.....	540
15.2.1	I ² C Bus Data Register (ICDR).....	540
15.2.2	Slave Address Register (SAR).....	543
15.2.3	Second Slave Address Register (SARX)	544
15.2.4	I ² C Bus Mode Register (ICMR)	545
15.2.5	I ² C Bus Control Register (ICCR)	549
15.2.6	I ² C Bus Status Register (ICSR)	557
15.2.7	Serial Control Register X (SCRX).....	563
15.2.8	DDC Switch Register (DDCSWR).....	564
15.2.9	Module Stop Control Register B (MSTPCRB)	565
15.3	Operation	566
15.3.1	I ² C Bus Data Format.....	566
15.3.2	Initial Setting	568
15.3.3	Master Transmit Operation.....	568
15.3.4	Master Receive Operation	572
15.3.5	Slave Receive Operation.....	577
15.3.6	Slave Transmit Operation	582
15.3.7	IRIC Setting Timing and SCL Control	585
15.3.8	Operation Using the DTC.....	586
15.3.9	Noise Canceler.....	587
15.3.10	Initialization of Internal State	587
15.4	Usage Notes	589
Section 16	Controller Area Network (HCAN)	601
16.1	Overview.....	601
16.1.1	Features.....	601
16.1.2	Block Diagram.....	603
16.1.3	Pin Configuration	604
16.1.4	Register Configuration.....	605
16.2	Register Descriptions.....	609
16.2.1	Master Control Register (MCR)	609
16.2.2	General Status Register (GSR)	610
16.2.3	Bit Configuration Register (BCR)	612

16.2.4	Mailbox Configuration Register (MBCR)	614
16.2.5	Transmit Wait Register (TXPR)	615
16.2.6	Transmit Wait Cancel Register (TXCR).....	616
16.2.7	Transmit Acknowledge Register (TXACK)	617
16.2.8	Abort Acknowledge Register (ABACK)	618
16.2.9	Receive Complete Register (RXPR).....	619
16.2.10	Remote Request Register (RFPR)	620
16.2.11	Interrupt Register (IRR).....	621
16.2.12	Mailbox Interrupt Mask Register (MBIMR)	626
16.2.13	Interrupt Mask Register (IMR)	627
16.2.14	Receive Error Counter (REC).....	630
16.2.15	Transmit Error Counter (TEC)	630
16.2.16	Unread Message Status Register (UMSR).....	631
16.2.17	Local Acceptance Filter Masks (LAFML, LAFMH).....	632
16.2.18	Message Control (MC0 to MC15)	634
16.2.19	Message Data (MD0 to MD15)	638
16.2.20	Module Stop Control Register C (MSTPCRC)	640
16.3	Operation	641
16.3.1	Hardware and Software Resets	641
16.3.2	Initialization after Hardware Reset	644
16.3.3	Transmit Mode	649
16.3.4	Receive Mode	655
16.3.5	HCAN Sleep Mode.....	661
16.3.6	HCAN Halt Mode.....	663
16.3.7	Interrupt Interface	663
16.3.8	DTC Interface	665
16.4	CAN Bus Interface	666
16.5	Usage Notes	667
Section 17 A/D Converter.....		671
17.1	Overview.....	671
17.1.1	Features.....	671
17.1.2	Block Diagram.....	672
17.1.3	Pin Configuration	673
17.1.4	Register Configuration.....	674
17.2	Register Descriptions.....	675
17.2.1	A/D Data Registers A to D (ADDRA to ADDRD)	675
17.2.2	A/D Control/Status Register (ADCSR)	676
17.2.3	A/D Control Register (ADCR)	679
17.2.4	Module Stop Control Register A (MSTPCRA)	680

17.3	Interface to Bus Master.....	681
17.4	Operation	682
17.4.1	Single Mode (SCAN = 0)	682
17.4.2	Scan Mode (SCAN = 1).....	684
17.4.3	Input Sampling and A/D Conversion Time	686
17.4.4	External Trigger Input Timing.....	687
17.5	Interrupts.....	688
17.6	Usage Notes	689
Section 18 D/A Converter.....		695
18.1	Overview.....	695
18.1.1	Features.....	695
18.1.2	Block Diagram.....	696
18.1.3	Input and Output Pins	697
18.1.4	Register Configuration.....	697
18.2	Register Descriptions	698
18.2.1	D/A Data Registers 0, 1 (DADR0, DADR1).....	698
18.2.2	D/A Control Register 01 (DACR01)	698
18.2.3	Module Stop Control Register A (MSTPCRA).....	700
18.3	Operation	701
Section 19 Motor Control PWM Timer.....		703
19.1	Overview.....	703
19.1.1	Features.....	703
19.1.2	Block Diagram.....	704
19.1.3	Pin Configuration	706
19.1.4	Register Configuration.....	707
19.2	Register Descriptions	708
19.2.1	PWM Control Registers 1 and 2 (PWCR1, PWCR2).....	708
19.2.2	PWM Output Control Registers 1 and 2 (PWOCR1, PWOCR2)	710
19.2.3	PWM Polarity Registers 1 and 2 (PWPR1, PWPR2)	711
19.2.4	PWM Counters 1 and 2 (PWCNT1, PWCNT2)	712
19.2.5	PWM Cycle Registers 1 and 2 (PWCYR1, PWCYR2).....	713
19.2.6	PWM Duty Registers 1A, 1C, 1E, 1G (PWDTR1A, 1C, 1E, 1G).....	714
19.2.7	PWM Buffer Registers 1A, 1C, 1E, 1G (PWBFR1A, 1C, 1E, 1G).....	716
19.2.8	PWM Duty Registers 2A to 2H (PWDTR2A to PWDTR2H).....	717
19.2.9	PWM Buffer Registers 2A to 2D (PWBFR2A to PWBFR2D)	719
19.2.10	Module Stop Control Register D (MSTPCRD)	720
19.3	Bus Master Interface.....	721
19.3.1	16-Bit Data Registers.....	721

19.3.2	8-Bit Data Registers.....	721
19.4	Operation	722
19.4.1	PWM Channel 1 Operation.....	722
19.4.2	PWM Channel 2 Operation.....	723
19.5	Usage Note	725
Section 20	RAM	727
20.1	Overview.....	727
20.1.1	Block Diagram.....	727
20.1.2	Register Configuration.....	729
20.2	Register Descriptions.....	730
20.2.1	System Control Register (SYSCR).....	730
20.3	Operation	730
20.4	Usage Notes	731
Section 21A	ROM (H8S/2636 Group).....	733
21A.1	Overview	733
21A.1.1	Block Diagram.....	733
21A.1.2	Register Configuration	733
21A.2	Register Descriptions	734
21A.2.1	Mode Control Register (MDCR).....	734
21A.3	Operation.....	734
21A.4	Flash Memory Overview	737
21A.4.1	Features	737
21A.4.2	Block Diagram.....	738
21A.4.3	Mode Transitions	739
21A.4.4	On-Board Programming Modes	740
21A.4.5	Flash Memory Emulation in RAM	742
21A.4.6	Differences between Boot Mode and User Program Mode	743
21A.4.7	Block Configuration	744
21A.5	Pin Configuration.....	745
21A.6	Register Configuration	746
21A.7	Register Descriptions	747
21A.7.1	Flash Memory Control Register 1 (FLMCR1)	747
21A.7.2	Flash Memory Control Register 2 (FLMCR2)	750
21A.7.3	Erase Block Register 1 (EBR1).....	751
21A.7.4	Erase Block Register 2 (EBR2).....	751
21A.7.5	RAM Emulation Register (RAMER)	752
21A.7.6	Flash Memory Power Control Register (FLPWCR).....	753
21A.8	On-Board Programming Modes	754

21A.8.1	Boot Mode	755
21A.8.2	User Program Mode	759
21A.9	Flash Memory Programming/Erasing	761
21A.9.1	Program Mode	763
21A.9.2	Program-Verify Mode	764
21A.9.3	Erase Mode	768
21A.9.4	Erase-Verify Mode	769
21A.10	Protection	771
21A.10.1	Hardware Protection	771
21A.10.2	Software Protection	772
21A.10.3	Error Protection	772
21A.11	Flash Memory Emulation in RAM.....	774
21A.12	Interrupt Handling when Programming/Erasing Flash Memory	776
21A.13	Flash Memory Programmer Mode	777
21A.13.1	Socket Adapter and Memory Map.....	777
21A.13.2	Programmer Mode Operation	778
21A.13.3	Memory Read Mode.....	779
21A.13.4	Auto-Program Mode.....	783
21A.13.5	Auto-Erase Mode.....	785
21A.13.6	Status Read Mode.....	787
21A.13.7	Status Polling	788
21A.13.8	Programmer Mode Transition Time	788
21A.13.9	Notes on Memory Programming	789
21A.14	Flash Memory and Power-Down States	790
21A.14.1	Notes on Power-Down States	790
21A.15	Flash Memory Programming and Erasing Precautions	791
21A.16	Note on Switching from F-ZTAT Version to Mask ROM Version	796
Section 21B	ROM (H8S/2638 Group, H8S/2639 Group, H8S/2630 Group)....	797
21B.1	Overview	797
21B.1.1	Block Diagram.....	797
21B.1.2	Register Configuration	798
21B.2	Register Descriptions	798
21B.2.1	Mode Control Register (MDCR)	798
21B.3	Operation.....	798
21B.4	Flash Memory Overview.....	801
21B.4.1	Features	801
21B.4.2	Block Diagram.....	802
21B.4.3	Mode Transitions.....	803
21B.4.4	On-Board Programming Modes	804

21B.4.5	Flash Memory Emulation in RAM	806
21B.4.6	Differences between Boot Mode and User Program Mode	807
21B.4.7	Block Configuration	808
21B.5	Pin Configuration	809
21B.6	Register Configuration	810
21B.7	Register Descriptions	811
21B.7.1	Flash Memory Control Register 1 (FLMCR1)	811
21B.7.2	Flash Memory Control Register 2 (FLMCR2)	814
21B.7.3	Erase Block Register 1 (EBR1)	815
21B.7.4	Erase Block Register 2 (EBR2)	815
21B.7.5	RAM Emulation Register (RAMER)	816
21B.7.6	Flash Memory Power Control Register (FLPWCR)	818
21B.8	On-Board Programming Modes	819
21B.8.1	Boot Mode	820
21B.8.2	User Program Mode	824
21B.9	Programming/Erasing Flash Memory	826
21B.9.1	Program Mode	828
21B.9.2	Program-Verify Mode	829
21B.9.3	Erase Mode	833
21B.9.4	Erase-Verify Mode	833
21B.10	Protection	835
21B.10.1	Hardware Protection	835
21B.10.2	Software Protection	836
21B.10.3	Error Protection	837
21B.11	Flash Memory Emulation in RAM	839
21B.12	Interrupt Handling when Programming/Erasing Flash Memory	841
21B.13	Flash Memory Programmer Mode	841
21B.13.1	Socket Adapter and Memory Map	842
21B.13.2	Programmer Mode Operation	843
21B.13.3	Memory Read Mode	844
21B.13.4	Auto-Program Mode	848
21B.13.5	Auto-Erase Mode	850
21B.13.6	Status Read Mode	852
21B.13.7	Status Polling	853
21B.13.8	Programmer Mode Transition Time	853
21B.13.9	Notes on Memory Programming	854
21B.14	Flash Memory and Power-Down States	855
21B.14.1	Notes on Power-Down States	856
21B.15	Flash Memory Programming and Erasing Precautions	856
21B.16	Note on Switching from F-ZTAT Version to Mask ROM Version	862

Section 21C	ROM (H8S/2635 Group)	863
21C.1	Overview	863
21C.1.1	Block Diagram	863
21C.1.2	Register Configuration	864
21C.2	Register Descriptions	864
21C.2.1	Mode Control Register (MDCR)	864
21C.3	Operation	864
21C.4	Flash Memory Overview	867
21C.4.1	Features	867
21C.4.2	Block Diagram	868
21C.4.3	Mode Transitions	869
21C.4.4	On-Board Programming Modes	870
21C.4.5	Flash Memory Emulation in RAM	872
21C.4.6	Differences between Boot Mode and User Program Mode	873
21C.4.7	Block Configuration	874
21C.5	Pin Configuration	875
21C.6	Register Configuration	876
21C.7	Register Descriptions	877
21C.7.1	Flash Memory Control Register 1 (FLMCR1)	877
21C.7.2	Flash Memory Control Register 2 (FLMCR2)	880
21C.7.3	Erase Block Register 1 (EBR1)	881
21C.7.4	Erase Block Register 2 (EBR2)	881
21C.7.5	RAM Emulation Register (RAMER)	882
21C.7.6	Flash Memory Power Control Register (FLPWCR)	884
21C.8	On-Board Programming Modes	885
21C.8.1	Boot Mode	886
21C.8.2	User Program Mode	890
21C.9	Programming/Erasing Flash Memory	892
21C.9.1	Program Mode	894
21C.9.2	Program-Verify Mode	895
21C.9.3	Erase Mode	899
21C.9.4	Erase-Verify Mode	899
21C.10	Protection	901
21C.10.1	Hardware Protection	901
21C.10.2	Software Protection	902
21C.10.3	Error Protection	903
21C.11	Flash Memory Emulation in RAM	905
21C.12	Interrupt Handling when Programming/Erasing Flash Memory	907
21C.13	Flash Memory Programmer Mode	907
21C.13.1	Socket Adapter and Memory Map	908

21C.13.2	Programmer Mode Operation	909
21C.13.3	Memory Read Mode	910
21C.13.4	Auto-Program Mode	914
21C.13.5	Auto-Erase Mode	916
21C.13.6	Status Read Mode	918
21C.13.7	Status Polling	919
21C.13.8	Programmer Mode Transition Time	919
21C.13.9	Notes on Memory Programming	920
21C.14	Flash Memory and Power-Down States	921
21C.14.1	Notes on Power-Down States	922
21C.15	Flash Memory Programming and Erasing Precautions	922
21C.16	Note on Switching from F-ZTAT Version to Mask ROM Version	928

Section 22A Clock Pulse Generator (H8S/2636 Group, H8S/2638 Group, H8S/2630 Group) 929

22A.1	Overview	929
22A.1.1	Block Diagram	929
22A.1.2	Register Configuration	930
22A.2	Register Descriptions	930
22A.2.1	System Clock Control Register (SCKCR)	930
22A.2.2	Low-Power Control Register (LPWRCR)	931
22A.3	Oscillator	932
22A.3.1	Connecting a Crystal Resonator	932
22A.3.2	External Clock Input	935
22A.4	PLL Circuit	937
22A.5	Medium-Speed Clock Divider	938
22A.6	Bus Master Clock Selection Circuit	938
22A.7	Subclock Oscillator	938
22A.8	Subclock Waveform Generation Circuit	939
22A.9	Note on Crystal Resonator	939

Section 22B Clock Pulse Generator (H8S/2639 Group, H8S/2635 Group) 941

22B.1	Overview	941
22B.1.1	Block Diagram	941
22B.1.2	Register Configuration	942
22B.2	Register Descriptions	942
22B.2.1	System Clock Control Register (SCKCR)	942
22B.2.2	Low-Power Control Register (LPWRCR)	943
22B.3	Oscillator	944
22B.3.1	Connecting a Crystal Resonator	944

22B.3.2	External Clock Input.....	947
22B.4	PLL Circuit.....	949
22B.5	Medium-Speed Clock Divider.....	949
22B.6	Bus Master Clock Selection Circuit	949
22B.7	Subclock Divider.....	950
22B.8	Note on Resonator.....	950

Section 23A Power-Down Modes

[HD64F2636F, HD64F2638F, HD6432636F, HD6432638F, HD64F2630F, HD6432630F, HD64F2635F, HD6432635F, HD6432634F]

		951
23A.1	Overview	951
	23A.1.1 Register Configuration	955
23A.2	Register Descriptions	956
	23A.2.1 Standby Control Register (SBYCR).....	956
	23A.2.2 System Clock Control Register (SCKCR).....	957
	23A.2.3 Low-Power Control Register (LPWRCR).....	959
	23A.2.4 Timer Control/Status Register (TCSR).....	959
	23A.2.5 Module Stop Control Register (MSTPCR).....	960
23A.3	Medium-Speed Mode.....	962
23A.4	Sleep Mode	963
	23A.4.1 Sleep Mode.....	963
	23A.4.2 Exiting Sleep Mode	963
23A.5	Module Stop Mode.....	964
	23A.5.1 Module Stop Mode	964
	23A.5.2 Usage Notes.....	965
23A.6	Software Standby Mode.....	966
	23A.6.1 Software Standby Mode	966
	23A.6.2 Clearing Software Standby Mode.....	966
	23A.6.3 Setting Oscillation Stabilization Time after Clearing Software Standby Mode.....	967
	23A.6.4 Software Standby Mode Application Example.....	968
	23A.6.5 Usage Notes.....	969
23A.7	Hardware Standby Mode.....	969
	23A.7.1 Hardware Standby Mode	969
	23A.7.2 Hardware Standby Mode Timing	970
23A.8	φ Clock Output Disabling Function.....	971

Section 23B Power-Down Modes

	[HD64F2636UF, HD6432636UF, HD64F2638UF, HD6432638UF, HD64F2638WF, HD6432638WF, HD64F2639UF, HD6432639UF, HD64F2639WF, HD6432639WF, HD64F2630UF, HD6432630UF, HD64F2630WF, HD6432630WF, HD6432635F, HD64F2635F, HD6432634F]	973
23B.1	Overview	973
23B.1.1	Register Configuration	979
23B.2	Register Descriptions	979
23B.2.1	Standby Control Register (SBYCR).....	979
23B.2.2	System Clock Control Register (SCKCR).....	981
23B.2.3	Low-Power Control Register (LPWRCR).....	983
23B.2.4	Timer Control/Status Register (TCSR).....	985
23B.2.5	Module Stop Control Register (MSTPCR).....	987
23B.3	Medium-Speed Mode.....	988
23B.4	Sleep Mode	989
23B.4.1	Sleep Mode.....	989
23B.4.2	Exiting Sleep Mode	989
23B.5	Module Stop Mode.....	990
23B.5.1	Module Stop Mode	990
23B.5.2	Usage Notes.....	992
23B.6	Software Standby Mode	992
23B.6.1	Software Standby Mode	992
23B.6.2	Clearing Software Standby Mode.....	993
23B.6.3	Setting Oscillation Stabilization Time after Clearing Software Standby Mode.....	993
23B.6.4	Software Standby Mode Application Example.....	995
23B.6.5	Usage Notes.....	996
23B.7	Hardware Standby Mode.....	996
23B.7.1	Hardware Standby Mode	996
23B.7.2	Hardware Standby Mode Timing	997
23B.8	Watch Mode (U-Mask, W-Mask Version, H8S/2635 Group Only).....	997
23B.8.1	Watch Mode	997
23B.8.2	Exiting Watch Mode.....	998
23B.8.3	Notes.....	998
23B.9	Subsleep Mode (U-Mask, W-Mask Version, H8S/2635 Group Only).....	999
23B.9.1	Subsleep Mode	999
23B.9.2	Exiting Subsleep Mode.....	999
23B.10	Subactive Mode (U-Mask, W-Mask Version, H8S/2635 Group Only)	1000
23B.10.1	Subactive Mode.....	1000

23B.10.2	Exiting Subactive Mode	1000
23B.11	Direct Transitions (U-Mask, W-Mask Version, H8S/2635 Group Only).....	1001
23B.11.1	Overview of Direct Transitions	1001
23B.12	φ Clock Output Disabling Function.....	1002
23B.13	Usage Notes	1003
Section 24	Electrical Characteristics	1005
24.1	H8S/2636 Group Electrical Characteristics	1005
24.1.1	Absolute Maximum Ratings	1005
24.1.2	Power Supply Voltage and Operating Frequency Range.....	1006
24.1.3	DC Characteristics	1007
24.1.4	AC Characteristics	1011
24.1.5	A/D Conversion Characteristics	1016
24.1.6	D/A Conversion Characteristics	1017
24.1.7	Flash Memory Characteristics	1018
24.2	H8S/2638 Group Electrical Characteristics	1020
24.2.1	Absolute Maximum Ratings	1020
24.2.2	Power Supply Voltage and Operating Frequency Range.....	1021
24.2.3	DC Characteristics	1022
24.2.4	AC Characteristics	1028
24.2.5	A/D Conversion Characteristics	1034
24.2.6	D/A Conversion Characteristics	1035
24.2.7	Flash Memory Characteristics	1036
24.3	H8S/2639 Group, H8S/2635 Group Electrical Characteristics	1038
24.3.1	Absolute Maximum Ratings	1038
24.3.2	Power Supply Voltage and Operating Frequency Range.....	1039
24.3.3	DC Characteristics	1040
24.3.4	AC Characteristics	1046
24.3.5	A/D Conversion Characteristics	1052
24.3.6	D/A Conversion Characteristics	1053
24.3.7	Flash Memory Characteristics	1054
24.4	H8S/2630 Group Electrical Characteristics	1056
24.4.1	Absolute Maximum Ratings	1056
24.4.2	Power Supply Voltage and Operating Frequency Range.....	1057
24.4.3	DC Characteristics	1058
24.4.4	AC Characteristics	1064
24.4.5	A/D Conversion Characteristics	1070
24.4.6	D/A Conversion Characteristics	1071
24.4.7	Flash Memory Characteristics	1072

24.5	Operation Timing.....	1074
24.5.1	Clock Timing.....	1074
24.5.2	Control Signal Timing.....	1075
24.5.3	Bus Timing.....	1076
24.5.4	On-Chip Supporting Module Timing.....	1080
24.6	Usage Note.....	1084
Appendix A	Instruction Set.....	1085
A.1	Instruction List.....	1085
A.2	Instruction Codes.....	1109
A.3	Operation Code Map.....	1124
A.4	Number of States Required for Instruction Execution.....	1128
A.5	Bus States during Instruction Execution.....	1142
A.6	Condition Code Modification.....	1156
Appendix B	Internal I/O Register.....	1162
B.1	Address.....	1162
B.2	Functions.....	1184
Appendix C	I/O Port Block Diagrams.....	1448
C.1	Port 1 Block Diagrams.....	1448
C.2	Port 3 Block Diagrams.....	1454
C.3	Port 4 Block Diagram.....	1460
C.4	Port 9 Block Diagram.....	1461
C.5	Port A Block Diagram.....	1462
C.6	Port B Block Diagram.....	1466
C.7	Port C Block Diagram.....	1467
C.8	Port D Block Diagram.....	1468
C.9	Port E Block Diagram.....	1469
C.10	Port F Block Diagrams.....	1470
C.11	Port H Block Diagram.....	1476
C.12	Port J Block Diagram.....	1477
Appendix D	Pin States.....	1478
D.1	Port States in Each Mode.....	1478
Appendix E	Timing of Transition to and Recovery from Hardware Standby Mode.....	1481

Appendix F Product Code Lineup..... 1482
Appendix G Package Dimensions..... 1484



Section 1 Overview

1.1 Overview

The H8S/2636, H8S/2638, H8S/2639, H8S/2630, H8S/2635, and H8S/2634 are microcomputers (MCUs: microcomputer units), built around the H8S/2600 CPU, employing Renesas Technology's proprietary architecture, and equipped with peripheral functions on-chip.

The H8S/2600 CPU has an internal 32-bit architecture, is provided with sixteen 16-bit general registers and a concise, optimized instruction set designed for high-speed operation, and can address a 16-Mbyte linear address space. The instruction set is upward-compatible with H8/300 and H8/300H CPU instructions at the object-code level, facilitating migration from the H8/300, H8/300L, or H8/300H Series.

On-chip peripheral functions required for system configuration include data transfer controller (DTC) bus masters, ROM and RAM memory, a 16-bit timer-pulse unit (TPU), programmable pulse generator (PPG), motor control PWM timer (PWM) watchdog timer (WDT), serial communication interface (SCI), A/D converter, D/A converter, controller area network (HCAN) and I/O ports. An I²C bus interface (IIC) is available as an option in the H8S/2638, H8S/2639, and H8S/2630.

On-chip ROM is available as 128-kbyte, 192-kbyte, 256-kbyte, and 384-kbyte flash memory (F-ZTAT™* version), and as 128-kbyte, 192-kbyte, 256-kbyte, and 384-kbyte mask ROM. ROM is connected to the CPU via a 16-bit data bus, enabling both byte and word data to be accessed in one state. Instruction fetching has been speeded up, and processing speed increased.

Four operating modes, modes 4 to 7, are provided, and there is a choice of single-chip mode or external expansion mode.

Subclock (32 kHz oscillation) functions are available in the U-mask and W-mask versions only. These functions cannot be used with the other versions.

The features of the H8S/2636, H8S/2638, H8S/2639, H8S/2630, H8S/2635, and H8S/2634 are shown in table 1-1.

Notes: The H8S/2635 and H8S/2634 are not equipped with a DTC, a PPG, or a D/A converter.

* F-ZTAT is a trademark of Renesas Technology Corp.

Table 1-1 Overview

Item	Specification
CPU	<ul style="list-style-type: none"> • General-register machine <ul style="list-style-type: none"> — Sixteen 16-bit general registers (also usable as sixteen 8-bit registers or eight 32-bit registers) • High-speed operation suitable for realtime control <ul style="list-style-type: none"> — Maximum clock rate: 20 MHz — High-speed arithmetic operations <ul style="list-style-type: none"> 8/16/32-bit register-register add/subtract : 50 ns 16 × 16-bit register-register multiply : 200 ns 16 × 16 + 42-bit multiply and accumulate : 200 ns 32 ÷ 16-bit register-register divide : 1000 ns • Instruction set suitable for high-speed operation <ul style="list-style-type: none"> — Sixty-nine basic instructions — 8/16/32-bit move/arithmetic and logic instructions — Unsigned/signed multiply and divide instructions — Multiply-and accumulate instruction — Powerful bit-manipulation instructions • CPU operating modes <ul style="list-style-type: none"> — Advanced mode: 16-Mbyte address space
Bus controller	<ul style="list-style-type: none"> • Address space divided into 8 areas, with bus specifications settable independently for each area • Choice of 8-bit or 16-bit access space for each area • 2-state or 3-state access space can be designated for each area • Number of program wait states can be set for each area • Direct connection to burst ROM supported
PC break controller (This function is not implemented in the H8S/2635 Group)	<ul style="list-style-type: none"> • Supports debugging functions by means of PC break interrupts • Two break channels
Data transfer controller (DTC) (This function is not implemented in the H8S/2635 Group)	<ul style="list-style-type: none"> • Can be activated by internal interrupt or software • Multiple transfers or multiple types of transfer possible for one activation source • Transfer possible in repeat mode, block transfer mode, etc. • Request can be sent to CPU for interrupt that activated DTC

Item	Specification
16-bit timer-pulse unit (TPU)	<ul style="list-style-type: none"> • 6-channel 16-bit timer on-chip • Pulse I/O processing capability for up to 16 pins' • Automatic 2-phase encoder count capability
Programmable pulse generator (PPG) (This function is not implemented in the H8S/2635 Group)	<ul style="list-style-type: none"> • Maximum 8-bit pulse output possible with TPU as time base • Output trigger selectable in 4-bit groups • Non-overlap margin can be set • Direct output or inverse output setting possible
Watchdog timer (WDT) 2 channels	<ul style="list-style-type: none"> • Watchdog timer or interval timer selectable • Operation using sub-clock supported (WDT1 only)*
Motor control PWM timer (PWM)	<ul style="list-style-type: none"> • Maximum of 16 10-bit PWM outputs • Eight outputs with two channels each built in • Duty settable between 0% and 100% • Automatic transfer of buffer register data supported • Settable to any one of 5 operating speeds
Serial communication interface (SCI) 3 channels (SCI0 to SCI2)	<ul style="list-style-type: none"> • Asynchronous mode or synchronous mode selectable • Multiprocessor communication function • Smart card interface function
Controller area network (HCAN) 2 channels (The H8S/2635 Group has one HCAN channel)	<ul style="list-style-type: none"> • CAN: Ver. 2.0B compliant • Buffer size: 15 transmit/receive messages, transmit only one message • Filtering of receive messages
A/D converter	<ul style="list-style-type: none"> • Resolution: 10 bits • Input: 12 channels • High-speed conversion: 13.3 μs minimum conversion time (at 20 MHz operation) • Single or scan mode selectable • Sample and hold circuit • A/D conversion can be activated by external trigger or timer trigger
D/A converter (This function is not implemented in the H8S/2635 Group)	<ul style="list-style-type: none"> • Resolution: 8 bits • Output: 2 channels

Item	Specification																					
I/O ports	<ul style="list-style-type: none"> 72 I/O pins, 12 input-only pins 																					
Memory	<ul style="list-style-type: none"> Flash memory or mask ROM High-speed static RAM <table border="1"> <thead> <tr> <th>Product Name</th> <th>ROM</th> <th>RAM</th> </tr> </thead> <tbody> <tr> <td>H8S/2636</td> <td>128 kbytes</td> <td>4 kbytes</td> </tr> <tr> <td>H8S/2638</td> <td>256 kbytes</td> <td>16 kbytes</td> </tr> <tr> <td>H8S/2639</td> <td></td> <td></td> </tr> <tr> <td>H8S/2630*</td> <td>384 kbytes</td> <td></td> </tr> <tr> <td>H8S/2635</td> <td>192 kbytes</td> <td>6 kbytes</td> </tr> <tr> <td>H8S/2634</td> <td>128 kbytes</td> <td></td> </tr> </tbody> </table> <p>Note: * Under development</p>	Product Name	ROM	RAM	H8S/2636	128 kbytes	4 kbytes	H8S/2638	256 kbytes	16 kbytes	H8S/2639			H8S/2630*	384 kbytes		H8S/2635	192 kbytes	6 kbytes	H8S/2634	128 kbytes	
Product Name	ROM	RAM																				
H8S/2636	128 kbytes	4 kbytes																				
H8S/2638	256 kbytes	16 kbytes																				
H8S/2639																						
H8S/2630*	384 kbytes																					
H8S/2635	192 kbytes	6 kbytes																				
H8S/2634	128 kbytes																					

Interrupt controller	<ul style="list-style-type: none"> Seven external interrupt pins ($\overline{\text{NMI}}$, $\overline{\text{IRQ0}}$ to $\overline{\text{IRQ5}}$) 49 internal interrupt sources (45 sources in H8S/2635) Eight priority levels settable
----------------------	--

Power-down states	<ul style="list-style-type: none"> Medium-speed mode Sleep mode Module-stop mode Software standby mode Hardware standby mode Sub-clock operation* (subactive mode, subsleep mode, watch mode)
-------------------	---

Operating modes	Four MCU operating modes				
				External Data Bus	
	CPU Operating		On-Chip	Initial	Maximum
Mode	Mode	Description	ROM	Value	Value
4	Advanced	On-chip ROM disabled expansion mode	Disabled	16 bits	16 bits
5		On-chip ROM disabled expansion mode	Disabled	8 bits	16 bits
6		On-chip ROM enabled expansion mode	Enabled	8 bits	16 bits
7		Single-chip mode	Enabled	—	—

Item	Specification
Clock pulse generator	<ul style="list-style-type: none"> On-chip PLL circuit (×1, ×2, ×4) Input clock frequency H8S/2636, H8S/2638, H8S/2630: 4 to 20 MHz H8S/2639, H8S/2635, H8S/2634: 4 to 5 MHz
I ² C bus interface (IIC) ×2 channel (Option) (Only for the H8S/2638, H8S/2639, and H8S/2630)	<ul style="list-style-type: none"> Conforms to the I²C bus interface type advocated by Philips Single master mode/slave mode Possible to determine arbitration lost conditions Supports two slave addresses
Packages	<ul style="list-style-type: none"> 128-pin plastic QFP (FP-128B)

Product lineup	Model Name				ROM/ RAM (Bytes)	Packages
	Mask ROM Version	F-ZTAT Version	Subclock Functions	I ² C bus interface		
	HD6432636F	HD64F2636F	No	—	128 k/ 4 k	FP-128B
	HD6432636UF (U-Mask Version)	HD64F2636UF (U-Mask Version)	Yes	—		
	HD6432638F	HD64F2638F	No	No	256 k/ 16 k	
	HD6432638UF (U-Mask Version)	HD64F2638UF (U-Mask Version)	Yes	No		
	HD6432638WF (W-Mask Version)	HD64F2638WF (W-Mask Version)	Yes	Yes		
	HD6432639UF (U-Mask Version)	HD64F2639UF (U-Mask Version)	Yes	No		
	HD6432639WF (W-Mask Version)	HD64F2639WF (W-Mask Version)	Yes	Yes		
	HD6432630F	HD64F2630F	No	No		
	HD6432630UF (U-Mask Version)	HD64F2630UF (U-Mask Version)	Yes	No	384 k/ 16 k	
	HD6432630WF (W-Mask Version)	HD64F2630WF (W-Mask Version)	Yes	Yes		
	HD6432635F	HD64F2635F	Yes	No	192 k/ 6 k	
	HD6432634F	—	Yes	No		
					128 k/ 6 k	

Note: * Under development

Note: * Subclock functions (subactive mode, subsleep mode, and watch mode) are available only in the U-mask and W-mask versions, and H8S/2635 Group, but are not available in the other versions.

1.2 Internal Block Diagram

Figure 1-1 (a) shows an internal block diagram of the H8S/2636.

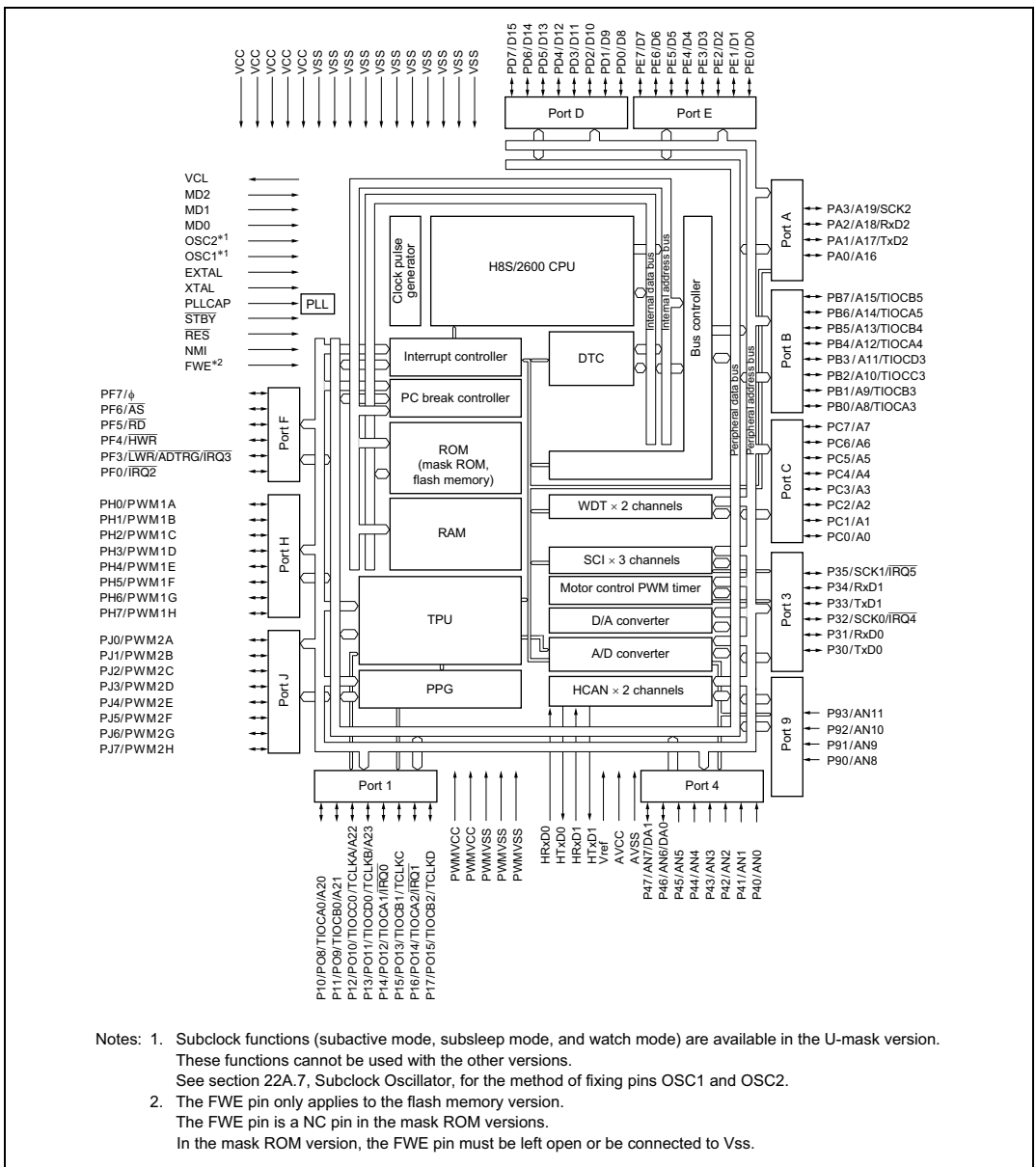
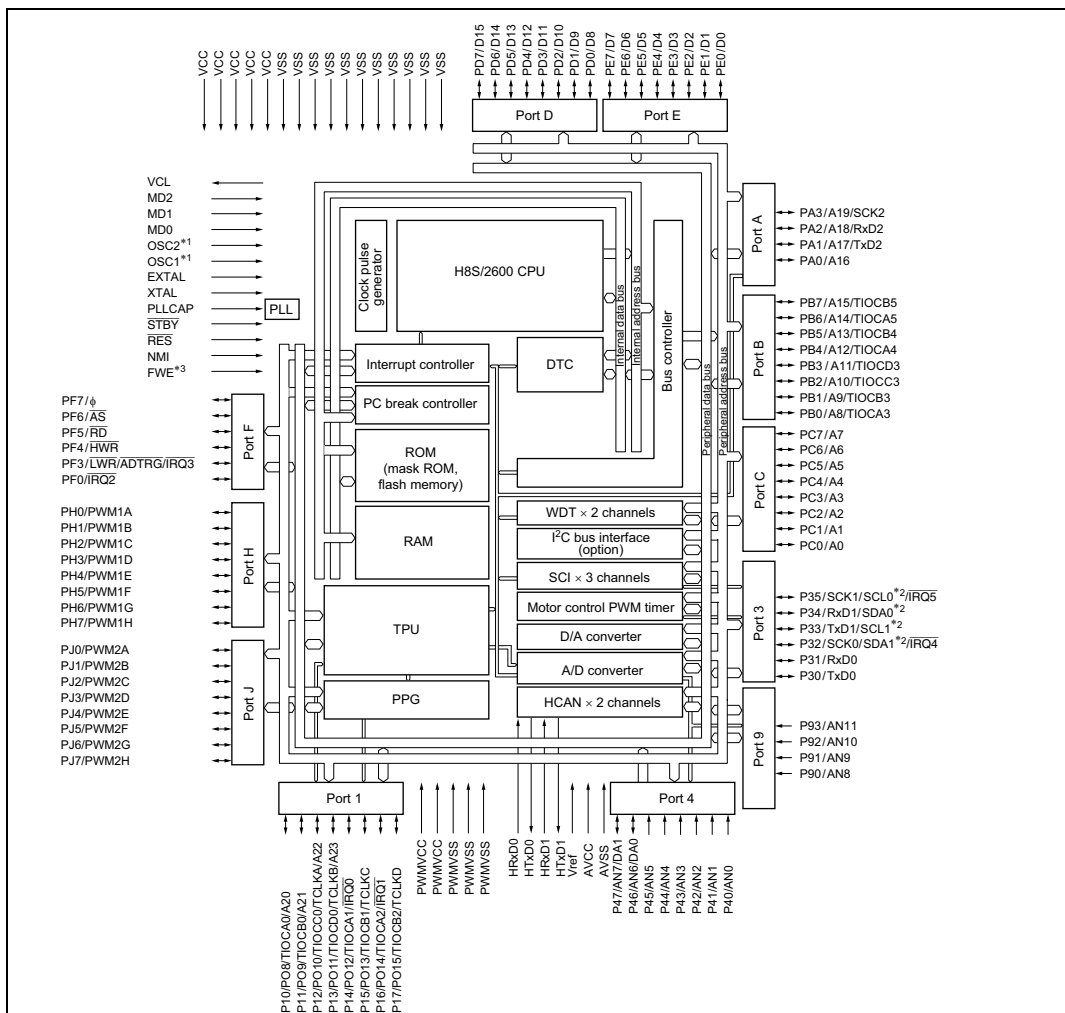

Figure 1-1 (a) Internal Block Diagram of H8S/2636

Figure 1-1 (b) shows an internal block diagram of the H8S/2638, H8S/2639, and H8S/2630.



- Notes:
1. Subclock functions (subactive mode, subsleep mode, and watch mode) are available in the U-mask and W-mask versions. These functions cannot be used with the other versions.
See section 22A.7, Subclock Oscillator, for the method of fixing pins OSC1 and OSC2.
The H8S/2639 has no OSC1 and OSC2 pins.
 2. These pins are used for the I²C bus interface.
The I²C bus interface is available as an option. The product equipped with the I²C bus interface is the W-mask version.
 3. The FWE pin is for compatibility with the flash memory version.
The FWE pin is a NC pin in the mask ROM versions.
In the mask ROM version, the FWE pin must be left open or be connected to Vss.

Figure 1-1 (b) Internal Block Diagram of H8S/2638, H8S/2639, and H8S/2630

Figure 1-1 (c) shows an internal block diagram of the H8S/2635 Group.

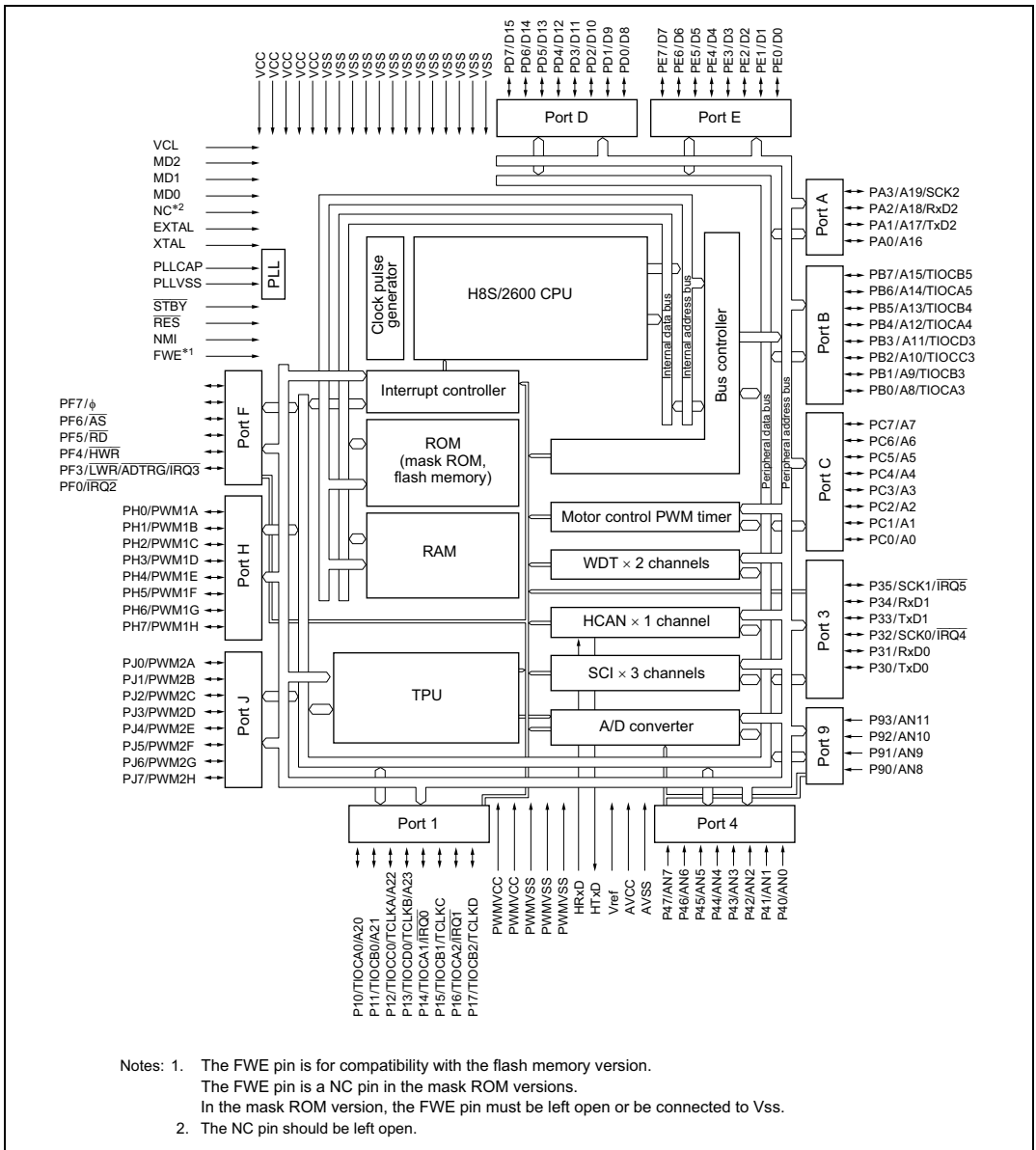

1.3 Pin Description

1.3.1 Pin Arrangement

Figure 1-2 shows the pin arrangement of the H8S/2636, figure 1-3 shows the pin arrangement of the H8S/2638 and H8S/2630, figure 1-4 shows the pin arrangement of the H8S/2639, and figure 1-5 shows the pin arrangement of the H8S/2635 Group.

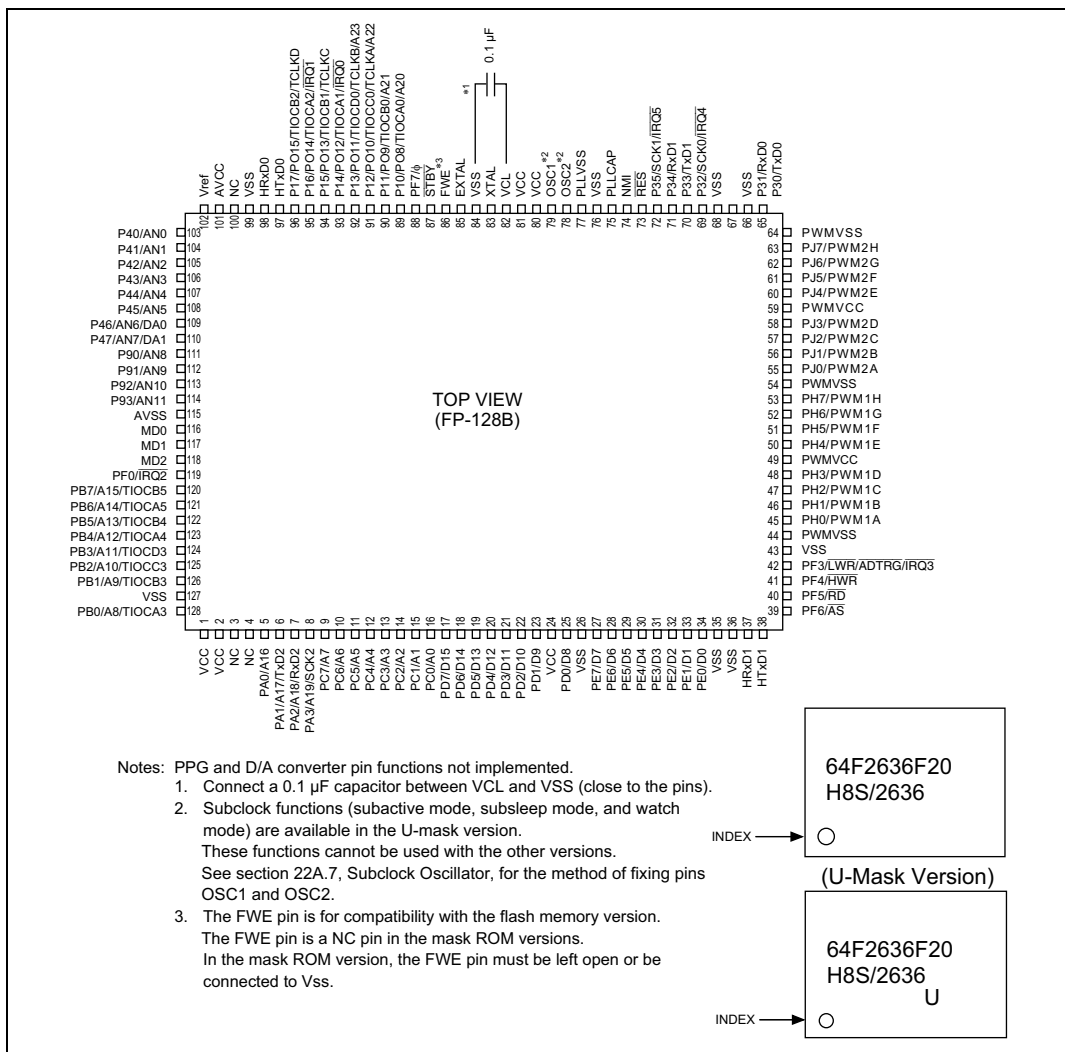

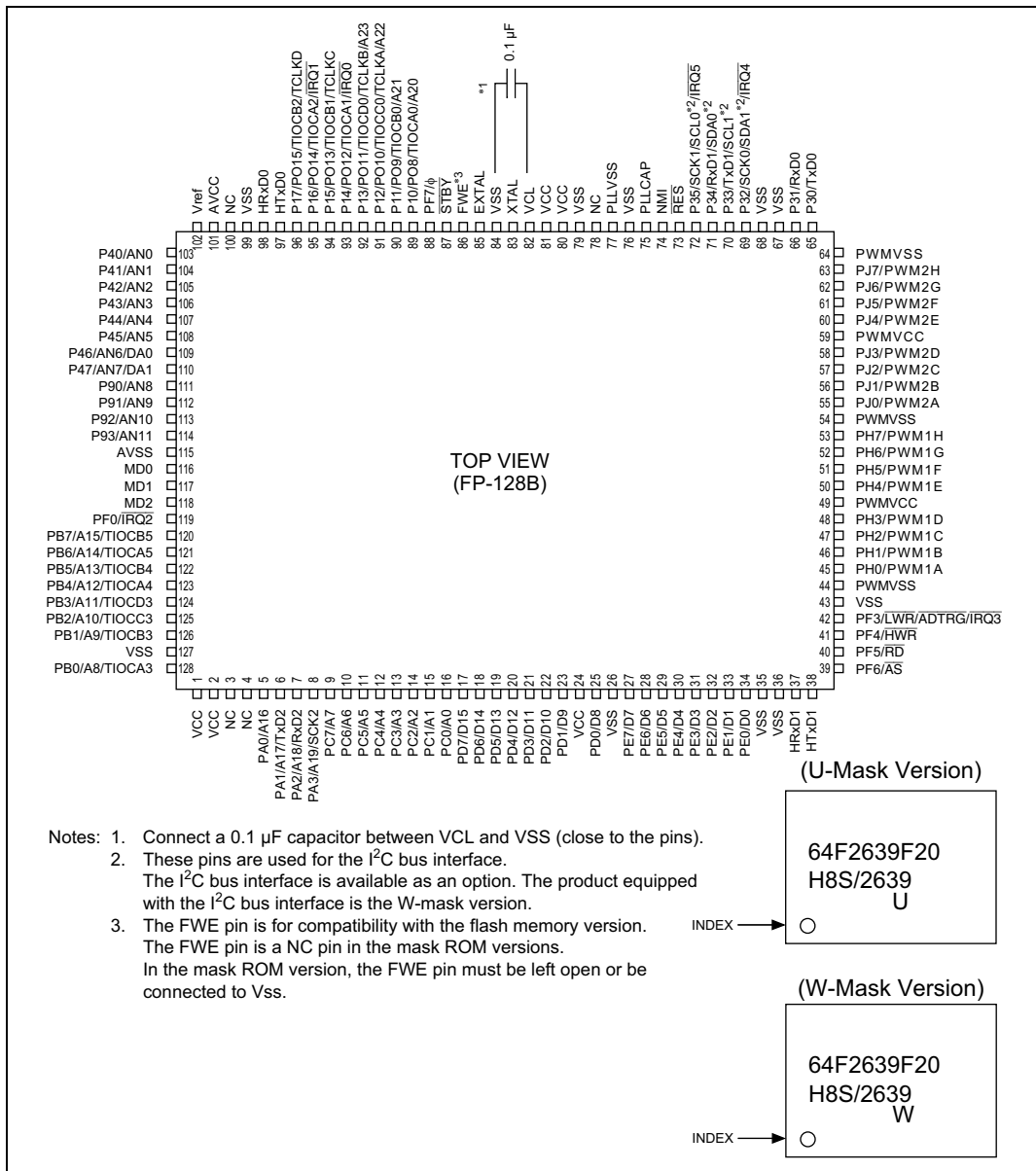

Figure 1-4 Pin Arrangement of H8S/2639 Group (FP-128B: Top View)

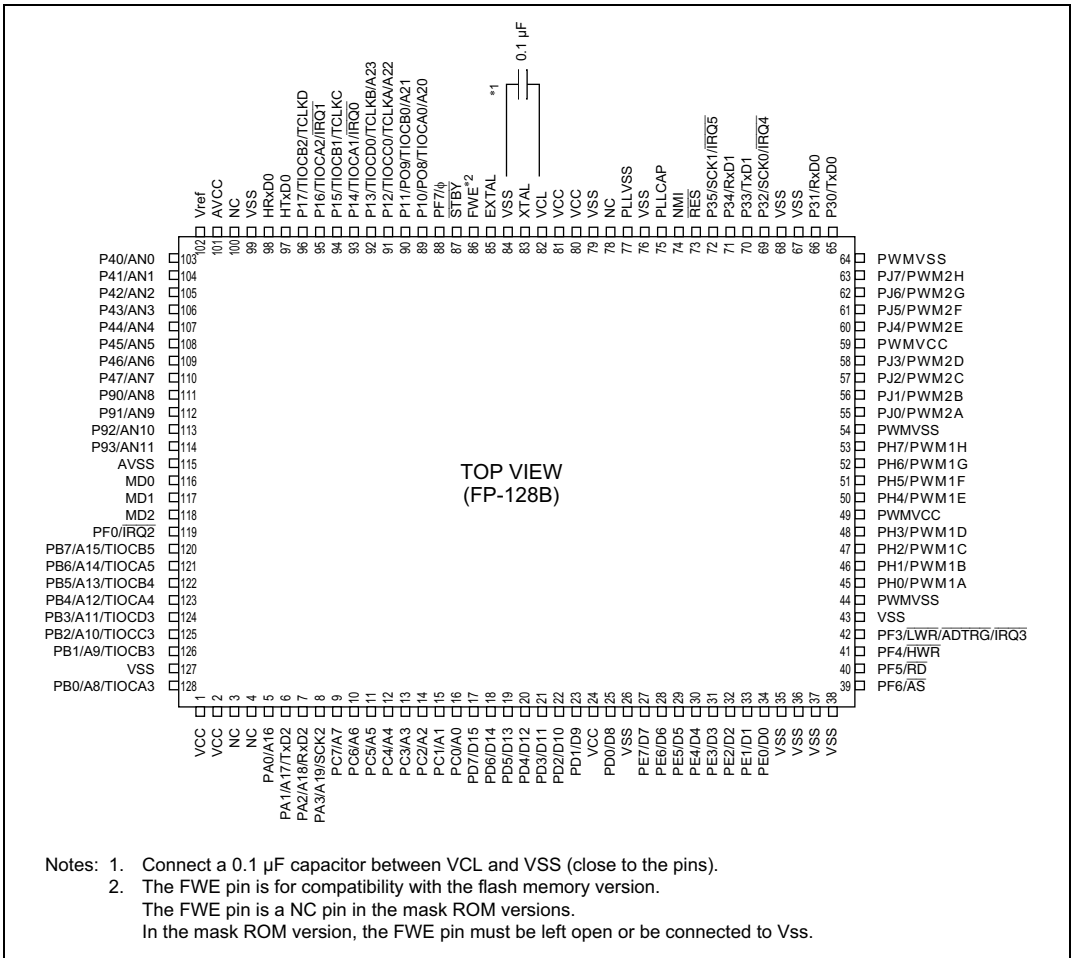

Figure 1-5 Pin Arrangement of H8S/2635 Group (FP-128B: Top View)

1.3.2 Pin Functions in Each Operating Mode

Table 1-2 shows the pin functions for each operating mode.

Table 1-2 Pin Functions in Each Operating Mode

Pin No.	Pin Name			
	Mode 4	Mode 5	Mode 6	Mode 7
1	VCC	VCC	VCC	VCC
2	VCC	VCC	VCC	VCC
3	NC	NC	NC	NC
4	NC	NC	NC	NC
5	PA0/A16	PA0/A16	PA0/A16	PA0
6	PA1/A17/TxD2	PA1/A17/TxD2	PA1/A17/TxD2	PA1/TxD2
7	PA2/A18/RxD2	PA2/A18/RxD2	PA2/A18/RxD2	PA2/RxD2
8	PA3/A19/SCK2	PA3/A19/SCK2	PA3/A19/SCK2	PA3/SCK2
9	A7	A7	PC7/A7	PC7
10	A6	A6	PC6/A6	PC6
11	A5	A5	PC5/A5	PC5
12	A4	A4	PC4/A4	PC4
13	A3	A3	PC3/A3	PC3
14	A2	A2	PC2/A2	PC2
15	A1	A1	PC1/A1	PC1
16	A0	A0	PC0/A0	PC0
17	D15	D15	D15	PD7
18	D14	D14	D14	PD6
19	D13	D13	D13	PD5
20	D12	D12	D12	PD4
21	D11	D11	D11	PD3
22	D10	D10	D10	PD2
23	D9	D9	D9	PD1
24	VCC	VCC	VCC	VCC
25	D8	D8	D8	PD0
26	VSS	VSS	VSS	VSS

Pin No.	Pin Name			
	Mode 4	Mode 5	Mode 6	Mode 7
27	PE7/D7	PE7/D7	PE7/D7	PE7
28	PE6/D6	PE6/D6	PE6/D6	PE6
29	PE5/D5	PE5/D5	PE5/D5	PE5
30	PE4/D4	PE4/D4	PE4/D4	PE4
31	PE3/D3	PE3/D3	PE3/D3	PE3
32	PE2/D2	PE2/D2	PE2/D2	PE2
33	PE1/D1	PE1/D1	PE1/D1	PE1
34	PE0/D0	PE0/D0	PE0/D0	PE0
35	VSS	VSS	VSS	VSS
36	VSS	VSS	VSS	VSS
37	HRxD1	HRxD1	HRxD1	HRxD1
38	HTxD1	HTxD1	HTxD1	HTxD1
39	\overline{AS}	\overline{AS}	\overline{AS}	PF6
40	\overline{RD}	\overline{RD}	\overline{RD}	PF5
41	\overline{HWR}	\overline{HWR}	\overline{HWR}	PF4
42	$\overline{LWR/ADTRG/}$ $\overline{IRQ3}$	PF3/ $\overline{LWR/ADTRG/}$ $\overline{IRQ3}$	PF3/ $\overline{LWR/ADTRG/}$ $\overline{IRQ3}$	PF3/ $\overline{ADTRG/}$ $\overline{IRQ3}$
43	VSS	VSS	VSS	VSS
44	PWMVSS	PWMVSS	PWMVSS	PWMVSS
45	PH0/PWM1A	PH0/PWM1A	PH0/PWM1A	PH0/PWM1A
46	PH1/PWM1B	PH1/PWM1B	PH1/PWM1B	PH1/PWM1B
47	PH2/PWM1C	PH2/PWM1C	PH2/PWM1C	PH2/PWM1C
48	PH3/PWM1D	PH3/PWM1D	PH3/PWM1D	PH3/PWM1D
49	PWMVCC	PWMVCC	PWMVCC	PWMVCC
50	PH4/PWM1E	PH4/PWM1E	PH4/PWM1E	PH4/PWM1E
51	PH5/PWM1F	PH5/PWM1F	PH5/PWM1F	PH5/PWM1F
52	PH6/PWM1G	PH6/PWM1G	PH6/PWM1G	PH6/PWM1G
53	PH7/PWM1H	PH7/PWM1H	PH7/PWM1H	PH7/PWM1H
54	PWMVSS	PWMVSS	PWMVSS	PWMVSS
55	PJ0/PWM2A	PJ0/PWM2A	PJ0/PWM2A	PJ0/PWM2A
56	PJ1/PWM2B	PJ1/PWM2B	PJ1/PWM2B	PJ1/PWM2B

Pin No.	Pin Name			
	Mode 4	Mode 5	Mode 6	Mode 7
57	PJ2/PWM2C	PJ2/PWM2C	PJ2/PWM2C	PJ2/PWM2C
58	PJ3/PWM2D	PJ3/PWM2D	PJ3/PWM2D	PJ3/PWM2D
59	PWMVCC	PWMVCC	PWMVCC	PWMVCC
60	PJ4/PWM2E	PJ4/PWM2E	PJ4/PWM2E	PJ4/PWM2E
61	PJ5/PWM2F	PJ5/PWM2F	PJ5/PWM2F	PJ5/PWM2F
62	PJ6/PWM2G	PJ6/PWM2G	PJ6/PWM2G	PJ6/PWM2G
63	PJ7/PWM2H	PJ7/PWM2H	PJ7/PWM2H	PJ7/PWM2H
64	PWMVSS	PWMVSS	PWMVSS	PWMVSS
65	P30/TxD0	P30/TxD0	P30/TxD0	P30/TxD0
66	P31/RxD0	P31/RxD0	P31/RxD0	P31/RxD0
67	VSS	VSS	VSS	VSS
68	VSS	VSS	VSS	VSS
69	P32/SCK0/SDA1 ^{*2} / IRQ4	P32/SCK0/SDA1 ^{*2} / IRQ4	P32/SCK0/SDA1 ^{*2} / IRQ4	P32/SCK0/SDA1 ^{*2} / IRQ4
70	P33/TxD1/SCL1 ^{*2}	P33/TxD1/SCL1 ^{*2}	P33/TxD1/SCL1 ^{*2}	P33/TxD1/SCL1 ^{*2}
71	P34/RxD1/SDA0 ^{*2}	P34/RxD1/SDA0 ^{*2}	P34/RxD1/SDA0 ^{*2}	P34/RxD1/SDA0 ^{*2}
72	P35/SCK1/SCL0 ^{*2} / IRQ5	P35/SCK1/SCL0 ^{*2} / IRQ5	P35/SCK1/SCL0 ^{*2} / IRQ5	P35/SCK1/SCL0 ^{*2} / IRQ5
73	RES	RES	RES	RES
74	NMI	NMI	NMI	NMI
75	PLLCAP	PLLCAP	PLLCAP	PLLCAP
76	VSS	VSS	VSS	VSS
77	PLLVSS	PLLVSS	PLLVSS	PLLVSS
78	OSC2 ^{*1}	OSC2 ^{*1}	OSC2 ^{*1}	OSC2 ^{*1}
79	OSC1 ^{*1}	OSC1 ^{*1}	OSC1 ^{*1}	OSC1 ^{*1}
80	VCC	VCC	VCC	VCC
81	VCC	VCC	VCC	VCC
82	VCL	VCL	VCL	VCL
83	XTAL	XTAL	XTAL	XTAL
84	VSS	VSS	VSS	VSS
85	EXTAL	EXTAL	EXTAL	EXTAL
86	FWE ^{*3}	FWE ^{*3}	FWE ^{*3}	FWE ^{*3}

Pin No.	Pin Name			
	Mode 4	Mode 5	Mode 6	Mode 7
87	STBY	STBY	STBY	STBY
88	PF7/ ϕ	PF7/ ϕ	PF7/ ϕ	PF7/ ϕ
89	P10/PO8 ^{*4} /TIOCA0/A20	P10/PO8 ^{*4} /TIOCA0/A20	P10/PO8 ^{*4} /TIOCA0/A20	P10/PO8 ^{*4} /TIOCA0
90	P11/PO9 ^{*4} /TIOCB0/A21	P11/PO9 ^{*4} /TIOCB0/A21	P11/PO9 ^{*4} /TIOCB0/A21	P11/PO9 ^{*4} /TIOCB0
91	P12/PO10 ^{*4} /TIOCC0/ TCLKA/A22	P12/PO10 ^{*4} /TIOCC0/ TCLKA/A22	P12/PO10 ^{*4} /TIOCC0/ TCLKA/A22	P12/PO10 ^{*4} /TIOCC0/ TCLKA
92	P13/PO11 ^{*4} /TIOCD0/ TCLKB/A23	P13/PO11 ^{*4} /TIOCD0/ TCLKB/A23	P13/PO11 ^{*4} /TIOCD0/ TCLKB/A23	P13/PO11 ^{*4} /TIOCD0/ TCLKB
93	P14/PO12 ^{*4} /TIOCA1/ $\overline{\text{IRQ0}}$	P14/PO12 ^{*4} /TIOCA1/ $\overline{\text{IRQ0}}$	P14/PO12 ^{*4} /TIOCA1/ $\overline{\text{IRQ0}}$	P14/PO12 ^{*4} /TIOCA1/ $\overline{\text{IRQ0}}$
94	P15/PO13 ^{*4} /TIOCB1/ TCLKC	P15/PO13 ^{*4} /TIOCB1/ TCLKC	P15/PO13 ^{*4} /TIOCB1/ TCLKC	P15/PO13 ^{*4} /TIOCB1/ TCLKC
95	P16/PO14 ^{*4} /TIOCA2/ $\overline{\text{IRQ1}}$	P16/PO14 ^{*4} /TIOCA2/ $\overline{\text{IRQ1}}$	P16/PO14 ^{*4} /TIOCA2/ $\overline{\text{IRQ1}}$	P16/PO14 ^{*4} /TIOCA2/ $\overline{\text{IRQ1}}$
96	P17/PO15 ^{*4} /TIOCB2/ TCLKD	P17/PO15 ^{*4} /TIOCB2/ TCLKD	P17/PO15 ^{*4} /TIOCB2/ TCLKD	P17/PO15 ^{*4} /TIOCB2/ TCLKD
97	HTxD0	HTxD0	HTxD0	HTxD0
98	HRxD0	HRxD0	HRxD0	HRxD0
99	VSS	VSS	VSS	VSS
100	NC	NC	NC	NC
101	AVCC	AVCC	AVCC	AVCC
102	Vref	Vref	Vref	Vref
103	P40/AN0	P40/AN0	P40/AN0	P40/AN0
104	P41/AN1	P41/AN1	P41/AN1	P41/AN1
105	P42/AN2	P42/AN2	P42/AN2	P42/AN2
106	P43/AN3	P43/AN3	P43/AN3	P43/AN3
107	P44/AN4	P44/AN4	P44/AN4	P44/AN4
108	P45/AN5	P45/AN5	P45/AN5	P45/AN5
109	P46/AN6/DA0 ^{*4}	P46/AN6/DA0 ^{*4}	P46/AN6/DA0 ^{*4}	P46/AN6/DA0 ^{*4}
110	P47/AN7/DA1 ^{*4}	P47/AN7/DA1 ^{*4}	P47/AN7/DA1 ^{*4}	P47/AN7/DA1 ^{*4}
111	P90/AN8	P90/AN8	P90/AN8	P90/AN8
112	P91/AN9	P91/AN9	P91/AN9	P91/AN9

Pin No.	Pin Name			
	Mode 4	Mode 5	Mode 6	Mode 7
113	P92/AN10	P92/AN10	P92/AN10	P92/AN10
114	P93/AN11	P93/AN11	P93/AN11	P93/AN11
115	AVSS	AVSS	AVSS	AVSS
116	MD0	MD0	MD0	MD0
117	MD1	MD1	MD1	MD1
118	MD2	MD2	MD2	MD2
119	PF0/ $\overline{\text{IRQ2}}$	PF0/ $\overline{\text{IRQ2}}$	PF0/ $\overline{\text{IRQ2}}$	PF0/ $\overline{\text{IRQ2}}$
120	PB7/A15/TIOCB5	PB7/A15/TIOCB5	PB7/A15/TIOCB5	PB7/TIOCB5
121	PB6/A14/TIOCA5	PB6/A14/TIOCA5	PB6/A14/TIOCA5	PB6/TIOCA5
122	PB5/A13/TIOCB4	PB5/A13/TIOCB4	PB5/A13/TIOCB4	PB5/TIOCB4
123	PB4/A12/TIOCA4	PB4/A12/TIOCA4	PB4/A12/TIOCA4	PB4/TIOCA4
124	PB3/A11/TIOCD3	PB3/A11/TIOCD3	PB3/A11/TIOCD3	PB3/TIOCD3
125	PB2/A10/TIOCC3	PB2/A10/TIOCC3	PB2/A10/TIOCC3	PB2/TIOCC3
126	PB1/A9/TIOCB3	PB1/A9/TIOCB3	PB1/A9/TIOCB3	PB1/TIOCB3
127	VSS	VSS	VSS	VSS
128	PB0/A8/TIOCA3	PB0/A8/TIOCA3	PB0/A8/TIOCA3	PB0/TIOCA3

Notes: NC pins should be connected to VSS or left open.

- Subclock functions (subactive mode, subsleep mode, and watch mode) are available in the U-mask and W-mask versions, and H8S/2635 Group.
These functions cannot be used with the other versions.
See section 22A.7, Subclock Oscillator, for the method of fixing pins OSC1 and OSC2.
The H8S/2639 and H8S/2635 Groups have no OSC1 and OSC2 pins.
- These pins are used for the I²C bus interface.
The I²C bus interface is available as an option (H8S/2638, H8S/2639, H8S/2630 only).
The product equipped with the I²C bus interface is the W-mask version.
- The FWE pin is for compatibility with the flash memory version.
The FWE pin is a NC pin in the mask ROM versions.
In the mask ROM version, the FWE pin must be left open or be connected to Vss.
- The PPG output, DA0, and DA1 are not supported in H8S/2635 Group.

1.3.3 Pin Functions

Table 1-3 outlines the pin functions of the H8S/2636.

Table 1-3 Pin Functions

Type	Symbol	I/O	Name and Function
Power	VCC	Input	Power supply: For connection to the power supply. All VCC pins should be connected to the system power supply.
	VSS	Input	Ground: For connection to ground (0 V). All VSS pins should be connected to the system power supply (0 V).
	VCL	Output	On-chip step-down power supply pin: The VCL pin need not be connected to the power supply. Connect this pin to VSS via a 0.1 μ F capacitor (placed close to the pins).
Clock	PLLVSS	Input	PLL ground: Ground for on-chip PLL oscillator.
	PLLCAP	Input	PLL capacitance: External capacitance pin for on-chip PLL oscillator.
	XTAL	Input	Crystal: Connects to a crystal oscillator. See section 22A, 22B, Clock Pulse Generator, for typical connection diagrams for a crystal oscillator.
	EXTAL	Input	External clock: Connects to a crystal oscillator. See section 22A, 22B, Clock Pulse Generator, for typical connection diagrams for a crystal oscillator.
	OSC1*1	Input	Subclock: Connects to a 32.768 kHz crystal oscillator. See section 22A, Clock Pulse Generator, for typical connection diagrams for a crystal oscillator.
	OSC2*1	Input	Subclock: Connects to a 32.768 kHz crystal oscillator. See section 22A, Clock Pulse Generator, for typical connection diagrams for a crystal oscillator.
	ϕ	Output	System clock: Supplies the system clock to an external device.
HCAN	HTxD0, HTxD1*3	Output	HCAN transmit data: Pin for CAN bus transmission.
	HRxD0, HRxD1*3	Input	HCAN receive data: Pin for CAN bus reception.

Type	Symbol	I/O	Name and Function																									
Operating mode control	MD2 to MD0	Input	Mode pins: These pins set the operating mode. The relation between the settings of pins MD2 to MD0 and the operating mode is shown below. These pins should not be changed while the H8S/2636 is operating.																									
			<table border="1"> <thead> <tr> <th>MD2</th> <th>MD1</th> <th>MD0</th> <th>Operating Mode</th> </tr> </thead> <tbody> <tr> <td rowspan="4">0</td> <td rowspan="2">0</td> <td>0</td> <td>—</td> </tr> <tr> <td>1</td> <td>—</td> </tr> <tr> <td rowspan="2">1</td> <td>0</td> <td>—</td> </tr> <tr> <td>1</td> <td>—</td> </tr> <tr> <td rowspan="3">1</td> <td rowspan="2">0</td> <td>0</td> <td>Mode 4</td> </tr> <tr> <td>1</td> <td>Mode 5</td> </tr> <tr> <td>1</td> <td>0</td> <td>Mode 6</td> </tr> <tr> <td></td> <td></td> <td>1</td> <td>Mode 7</td> </tr> </tbody> </table>	MD2	MD1	MD0	Operating Mode	0	0	0	—	1	—	1	0	—	1	—	1	0	0	Mode 4	1	Mode 5	1	0	Mode 6	
MD2	MD1	MD0	Operating Mode																									
0	0	0	—																									
		1	—																									
	1	0	—																									
		1	—																									
1	0	0	Mode 4																									
		1	Mode 5																									
	1	0	Mode 6																									
		1	Mode 7																									
System control	$\overline{\text{RES}}$	Input	Reset input: When this pin is driven low, the chip is reset.																									
	$\overline{\text{STBY}}$	Input	Standby: When this pin is driven low, a transition is made to hardware standby mode.																									
	FWE^{*2}	Input	Flash write enable: Pin for flash memory use (in planning stage).																									
Interrupts	NMI	Input	Nonmaskable interrupt: Requests a nonmaskable interrupt. When this pin is not used, it should be fixed high.																									
	$\overline{\text{IRQ5}}$ to $\overline{\text{IRQ0}}$	Input	Interrupt request 5 to 0: These pins request a maskable interrupt.																									
Address bus	A23 to A0	Output	Address bus: These pins output an address.																									
Data bus	D15 to D0	I/O	Data bus: These pins constitute a bidirectional data bus.																									
Bus control	$\overline{\text{AS}}$	Output	Address strobe: When this pin is low, it indicates that address output on the address bus is enabled.																									
	$\overline{\text{RD}}$	Output	Read: When this pin is low, it indicates that the external address space can be read.																									
	$\overline{\text{HWR}}$	Output	High write: A strobe signal that writes to external space and indicates that the upper half (D15 to D8) of the data bus is enabled.																									

Type	Symbol	I/O	Name and Function
Bus control	$\overline{\text{LWR}}$	Output	Low write: A strobe signal that writes to external space and indicates that the lower half (D7 to D0) of the data bus is enabled.
16-bit timer-pulse unit (TPU)	TCLKD to TCLKA	Input	Clock input D to A: These pins input an external clock.
	TIOCA0, TIOCB0, TIOCC0, TIOCD0	I/O	Input capture/output compare match A0 to D0: The TGR0A to TGR0D input capture input or output compare output, or PWM output pins.
	TIOCA1, TIOCB1	I/O	Input capture/output compare match A1 and B1: The TGR1A and TGR1B input capture input or output compare output, or PWM output pins.
	TIOCA2, TIOCB2	I/O	Input capture/output compare match A2 and B2: The TGR2A and TGR2B input capture input or output compare output, or PWM output pins.
	TIOCA3, TIOCB3, TIOCC3, TIOCD3	I/O	Input capture/output compare match A3 to D3: The TGR3A to TGR3D input capture input or output compare output, or PWM output pins.
	TIOCA4, TIOCB4	I/O	Input capture/output compare match A4 and B4: The TGR4A and TGR4B input capture input or output compare output, or PWM output pins.
	TIOCA5, TIOCB5	I/O	Input capture/output compare match A5 and B5: The TGR5A and TGR5B input capture input or output compare output, or PWM output pins.
Programmable pulse generator (PPG)	PO15 to PO8*4	Output	Pulse output 15 to 8: Pulse output pins.
Serial communication interface (SCI)/ Smart Card interface	TxD2, TxD1, TxD0	Output	Transmit data (channel 0, 1, 2): Data output pins.
	RxD2, RxD1, RxD0	Input	Receive data (channel 0, 1, 2): Data input pins.
	SCK2, SCK1, SCK0	I/O	Serial clock (channel 0, 1, 2): Clock I/O pins.
A/D converter	AN11 to AN0	Input	Analog 11 to 0: Analog input pins.
	$\overline{\text{ADTRG}}$	Input	A/D conversion external trigger input: Pin for input of an external trigger to start A/D conversion.

Type	Symbol	I/O	Name and Function
D/A converter	DA1, DA0 ^{*5}	Output	Analog output: Analog output pins for D/A converter.
A/D converter, D/A converter	AVCC	Input	Analog power supply: A/D converter and D/A converter power supply pin. When the A/D converter and D/A converter are not used, this pin should be connected to the system power supply (+5 V).
	AVSS	Input	Analog ground: Ground pin for A/D converter and D/A converter. Connect to system power supply (0 V).
	Vref	Input	Analog reference power supply: A/D converter and D/A converter reference voltage input pin. When the A/D converter and D/A converter are not used, this pin should be connected to the system power supply (+5 V).
I/O ports	P17 to P10	I/O	Port 1: An 8-bit I/O port. Input or output can be designated for each bit by means of the port 1 data direction register (P1DDR).
	P35 to P30	I/O	Port 3: A 6-bit I/O port. Input or output can be designated for each bit by means of the port 3 data direction register (P3DDR).
	P47 to P40	Input	Port 4: An 8-bit input port.
	P93 to P90	Input	Port 9: A 4-bit input port.
	PA3 to PA0	I/O	Port A: A 4-bit I/O port. Input or output can be designated for each bit by means of the port A data direction register (PADDR).
	PB7 to PB0	I/O	Port B: An 8-bit I/O port. Input or output can be designated for each bit by means of the port B data direction register (PBDDR).
	PC7 to PC0	I/O	Port C: An 8-bit I/O port. Input or output can be designated for each bit by means of the port C data direction register (PCDDR).
	PD7 to PD0	I/O	Port D: An 8-bit I/O port. Input or output can be designated for each bit by means of the port D data direction register (PDDDR).
	PE7 to PE0	I/O	Port E: An 8-bit I/O port. Input or output can be designated for each bit by means of the port E data direction register (PEDDR).

Type	Symbol	I/O	Name and Function
I/O ports	PF7 to PF3, PF0	I/O	Port F: A 6-bit I/O port. Input or output can be designated for each bit by means of the port F data direction register (PFDDR).
	PH7 to PH0	I/O	Port H: An 8-bit I/O port. Input or output can be designated for each bit by means of the port B data direction register (PHDDR).
	PJ7 to PJ0	I/O	Port J: An 8-bit I/O port. Input or output can be designated for each bit by means of the port J data direction register (PJDDR).
Motor control PWM	PWM1A to PWM1H	Output	PWM output: Motor control PWM channel 1 output pins.
	PWM2A to PWM2H	Output	PWM output: Motor control PWM channel 2 output pins.
	PWMVCC	Input	PWM Power Supply: Power supply pin for motor-control PWM. Connect to the system power supply (+5 V) when the motor-control function is not used.
	PWMVSS	Input	PWM Ground: Ground pin for motor-control PWM. Connect to the system power supply (0 V).
I ² C bus interface (IIC) (Optionk) (Only for the W- mask version of the H8S/2638, H8S/2639, and H8S/2630)	SCL0, SCL1	I/O	I ² C clock input/output (Channel 0/1): I ² C clock input/output pins that have bus-driving capability. The output of SCL0 is an NMOS open-drain type.
	SDA0, SDA1	I/O	I ² C data input/output (Channel 0/1): I ² C data input/output pins that have bus-driving capability. The output of SDA0 is an NMOS open-drain type.

- Notes: 1. Subclock functions (subactive mode, subsleep mode, and watch mode) are available in the U-mask and W-mask versions, and H8S/2635 Group.
These functions cannot be used with the other versions.
See section 22A.7, Subclock Oscillator, for the method of fixing pins OSC1 and OSC2.
The H8S/2639 and H8S/2635 Groups have no OSC1 and OSC2 pins.
2. The FWE pin is functional only in the flash memory version. The FWE pin is a NC pin in the mask ROM versions. In the mask ROM version, the FWE pin must be left open or be connected to Vss.
3. The HTxD1 and HRxD1 pins are not supported in H8S/2635 Group.
4. The PO15 to PO8 output are not supported in H8S/2635 Group.
5. The DA1 and DA0 output are not supported in H8S/2635 Group.

1.4 Differences between H8S/2636, H8S/2638, H8S/2639, H8S/2630, H8S/2635, and H8S/2634

There are four versions of the H8S/2636, including ROM and U-mask options; there are six versions of the H8S/2638, including ROM, U-mask, and W-mask options; and there are four versions of the H8S/2639, including ROM, U-mask, and W-mask options; and there are six versions of the H8S/2630, including ROM, U-mask, and W-mask options.

The specifications of these products are compared in table 1-4 below.

Table 1-4 Comparison of Product Specifications

Product Type	Model	Product Specifications						
		ROM	RAM	Subclock Function	I ² C Bus Interface	HCAN	DTC, PBC, PPG, DAC	Power-Down Modes
H8S/2636	HD64F2636F	128-kbyte on-chip flash memory	4-kbyte SRAM	No	No	2 channels	Yes	See section 23A, Power-Down Modes
	HD64F2636UF			Yes				See section 23B, Power-Down Modes
	HD6432636F	128-kbyte mask ROM		No	No			See section 23A, Power-Down Modes
	HD6432636UF			Yes				See section 23B, Power-Down Modes
H8S/2638	HD64F2638F	256-kbyte on-chip flash memory	16-kbyte SRAM	No	No			See section 23A, Power-Down Modes
	HD64F2638UF			Yes	Yes			See section 23B, Power-Down Modes
	HD64F2638WF							See section 23A, Power-Down Modes
	HD6432638F	256-kbyte mask ROM		No	No			See section 23A, Power-Down Modes
	HD6432638UF			Yes	Yes			See section 23B, Power-Down Modes
	HD6432638WF							See section 23B, Power-Down Modes

Product Type	Model	Product Specifications						
		ROM	RAM	Subclock Function	I ² C Bus Interface	HCAN	DTC, PBC, PPG, DAC	Power-Down Modes
H8S/2639* ¹	HD64F2639UF	256-kbyte on-chip flash memory	16-kbyte SRAM	Yes	No	2 channels	Yes	See section 23B, Power-Down Modes
	HD64F2639WF				Yes			
	HD6432639UF	256-kbyte mask ROM			No			
	HD6432639WF				Yes			
H8S/2630	HD64F2630F	384-kbyte on-chip flash memory	16-kbyte SRAM	No	No	2 channels	Yes	See section 23B, Power-Down Modes
	HD64F2630UF				Yes			See section 23B, Power-Down Modes
	HD64F2630WF				Yes			
	HD6432630F	384-kbyte mask ROM		No	No			See section 23A, Power-Down Modes
	HD6432630UF			Yes	Yes			See section 23B, Power-Down Modes
	HD6432630WF							
H8S/2635* ¹	HD64F2635F	192-kbyte on-chip flash memory	6-kbyte SRAM	Yes	No	1 channel	No	
	HD6432635F* ²	192-kbyte mask ROM						
H8S/2634* ¹	HD6432634F* ²	128-kbyte mask ROM						

- Notes: 1. For details of the H8S/2639, H8S/2635, and H8S/2634 clock pulse generator, see section 22B, Clock Pulse Generator (H8S/2639 Group, H8S/2635 Group).
2. Under development

Section 2 CPU

2.1 Overview

The H8S/2600 CPU is a high-speed central processing unit with an internal 32-bit architecture that is upward-compatible with the H8/300 and H8/300H CPUs. The H8S/2600 CPU has sixteen 16-bit general registers, can address a 16-Mbyte (architecturally 4-Gbyte) linear address space, and is ideal for realtime control.

2.1.1 Features

The H8S/2600 CPU has the following features.

- Upward-compatible with H8/300 and H8/300H CPUs
 - Can execute H8/300 and H8/300H object programs
- General-register architecture
 - Sixteen 16-bit general registers (also usable as sixteen 8-bit registers or eight 32-bit registers)
- Sixty-nine basic instructions
 - 8/16/32-bit arithmetic and logic instructions
 - Multiply and divide instructions
 - Powerful bit-manipulation instructions
 - Multiply-and-accumulate instruction
- Eight addressing modes
 - Register direct [Rn]
 - Register indirect [@ERn]
 - Register indirect with displacement [@(d:16,ERn) or @(d:32,ERn)]
 - Register indirect with post-increment or pre-decrement [@ERn+ or @-ERn]
 - Absolute address [@aa:8, @aa:16, @aa:24, or @aa:32]
 - Immediate [#xx:8, #xx:16, or #xx:32]
 - Program-counter relative [@(d:8,PC) or @(d:16,PC)]
 - Memory indirect [@@aa:8]
- 16-Mbyte address space
 - Program: 16 Mbytes
 - Data: 16 Mbytes (4 Gbytes architecturally)

- High-speed operation
 - All frequently-used instructions execute in one or two states
 - Maximum clock rate : 20 MHz
 - 8/16/32-bit register-register add/subtract : 50 ns
 - 8×8 -bit register-register multiply : 150 ns
 - $16 \div 8$ -bit register-register divide : 600 ns
 - 16×16 -bit register-register multiply : 200 ns
 - $32 \div 16$ -bit register-register divide : 1000 ns
- Two CPU operating modes
 - Normal mode*
 - Advanced mode

Note: * Not available in the chip.

- Power-down state
 - Transition to power-down state by SLEEP instruction
 - CPU clock speed selection

2.1.2 Differences between H8S/2600 CPU and H8S/2000 CPU

The differences between the H8S/2600 CPU and the H8S/2000 CPU are as shown below.

- Register configuration

The MAC register is supported only by the H8S/2600 CPU.
- Basic instructions

The four instructions MAC, CLRMAC, LDMAC, and STMAC are supported only by the H8S/2600 CPU.
- Number of execution states

The number of execution states of the MULXU and MULXS instructions is different in each CPU.

Instruction	Mnemonic	Execution States	
		H8S/2600	H8S/2000
MULXU	MULXU.B Rs, Rd	3	12
	MULXU.W Rs, ERd	4	20
MULXS	MULXS.B Rs, Rd	4	13
	MULXS.W Rs, ERd	5	21

In addition, there are differences in address space, CCR and EXR register functions, power-down modes, etc., depending on the model.

2.1.3 Differences from H8/300 CPU

In comparison to the H8/300 CPU, the H8S/2600 CPU has the following enhancements.

- More general registers and control registers
 - Eight 16-bit expanded registers, and one 8-bit and two 32-bit control registers, have been added
- Expanded address space
 - Normal mode* supports the same 64-kbyte address space as the H8/300 CPU
 - Advanced mode supports a maximum 16-Mbyte address space

Note: * Not available in the chip.

- Enhanced addressing
 - The addressing modes have been enhanced to make effective use of the 16-Mbyte address space
- Enhanced instructions
 - Addressing modes of bit-manipulation instructions have been enhanced
 - Signed multiply and divide instructions have been added
 - A multiply-and-accumulate instruction has been added
 - Two-bit shift instructions have been added
 - Instructions for saving and restoring multiple registers have been added
 - A test and set instruction has been added
- Higher speed
 - Basic instructions execute twice as fast

2.1.4 Differences from H8/300H CPU

In comparison to the H8/300H CPU, the H8S/2600 CPU has the following enhancements.

- Additional control register
 - One 8-bit and two 32-bit control registers have been added
- Enhanced instructions
 - Addressing modes of bit-manipulation instructions have been enhanced
 - A multiply-and-accumulate instruction has been added
 - Two-bit shift instructions have been added
 - Instructions for saving and restoring multiple registers have been added
 - A test and set instruction has been added
- Higher speed
 - Basic instructions execute twice as fast

2.2 CPU Operating Modes

The H8S/2600 CPU has two operating modes: normal and advanced. Normal mode* supports a maximum 64-kbyte address space. Advanced mode supports a maximum 16-Mbyte total address space (architecturally a maximum 16-Mbyte program area and a maximum of 4 Gbytes for program and data areas combined). The mode is selected by the mode pins of the microcontroller.

Note: * Not available in the chip.

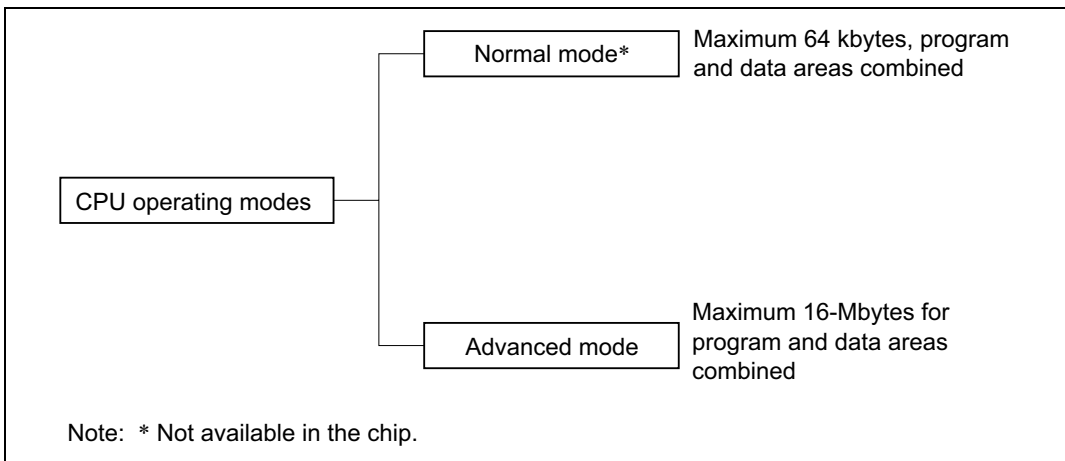

Figure 2-1 CPU Operating Modes

(1) Normal Mode (Not Available in the Chip)

The exception vector table and stack have the same structure as in the H8/300 CPU.

Address Space: A maximum address space of 64 kbytes can be accessed.

Extended Registers (En): The extended registers (E0 to E7) can be used as 16-bit registers, or as the upper 16-bit segments of 32-bit registers. When En is used as a 16-bit register it can contain any value, even when the corresponding general register (Rn) is used as an address register. If the general register is referenced in the register indirect addressing mode with pre-decrement (@-Rn) or post-increment (@Rn+) and a carry or borrow occurs, however, the value in the corresponding extended register (En) will be affected.

Instruction Set: All instructions and addressing modes can be used. Only the lower 16 bits of effective addresses (EA) are valid.

Exception Vector Table and Memory Indirect Branch Addresses: In normal mode the top area starting at H'0000 is allocated to the exception vector table. One branch address is stored per 16 bits (figure 2-2). The exception vector table differs depending on the microcontroller. For details of the exception vector table, see section 4, Exception Handling.

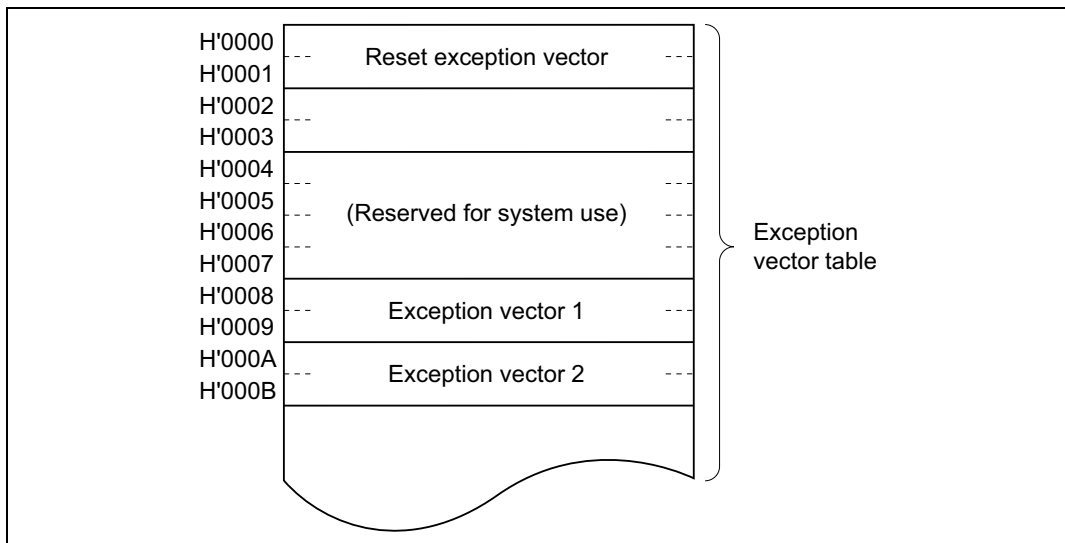

Figure 2-2 Exception Vector Table (Normal Mode)

The memory indirect addressing mode (@@aa:8) employed in the JMP and JSR instructions uses an 8-bit absolute address included in the instruction code to specify a memory operand that contains a branch address. In normal mode the operand is a 16-bit word operand, providing a 16-

bit branch address. Branch addresses can be stored in the top area from H'0000 to H'00FF. Note that this area is also used for the exception vector table.

Stack Structure: When the program counter (PC) is pushed onto the stack in a subroutine call, and the PC, condition-code register (CCR), and extended control register (EXR) are pushed onto the stack in exception handling, they are stored as shown in figure 2-3. When EXR is invalid, it is not pushed onto the stack. For details, see section 4, Exception Handling.

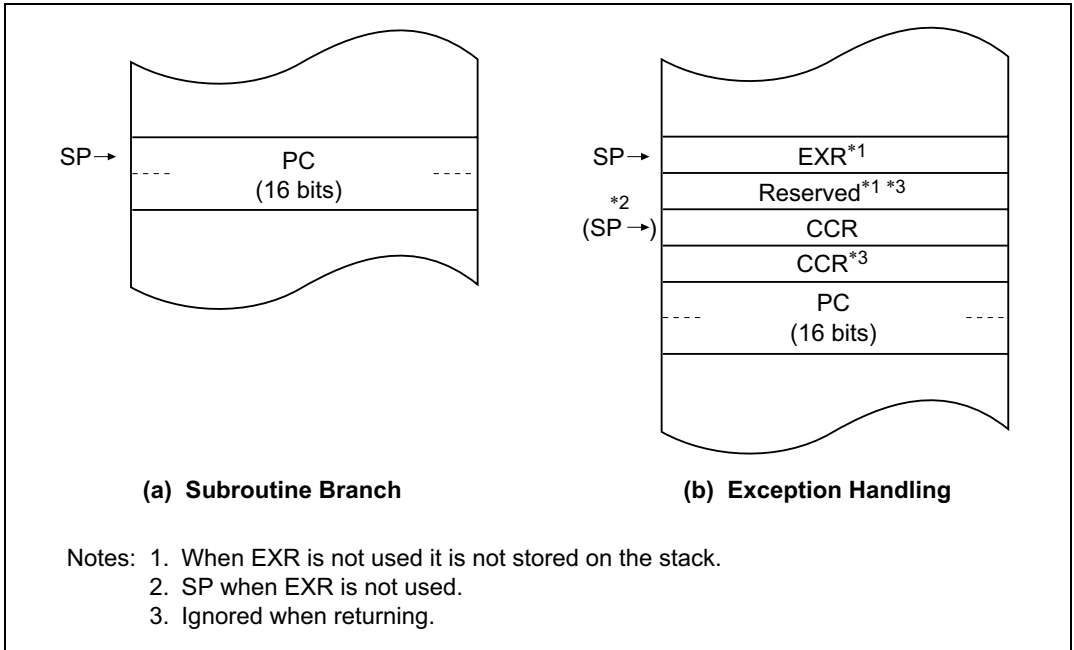

Figure 2-3 Stack Structure in Normal Mode

(2) Advanced Mode

Address Space: Linear access is provided to a 16-Mbyte maximum address space (architecturally a maximum 16-Mbyte program area and a maximum 4-Gbyte data area, with a maximum of 4 Gbytes for program and data areas combined).

Extended Registers (En): The extended registers (E0 to E7) can be used as 16-bit registers, or as the upper 16-bit segments of 32-bit registers or address registers.

Instruction Set: All instructions and addressing modes can be used.

Exception Vector Table and Memory Indirect Branch Addresses: In advanced mode the top area starting at H'00000000 is allocated to the exception vector table in units of 32 bits. In each 32 bits, the upper 8 bits are ignored and a branch address is stored in the lower 24 bits (figure 2-4). For details of the exception vector table, see section 4, Exception Handling.

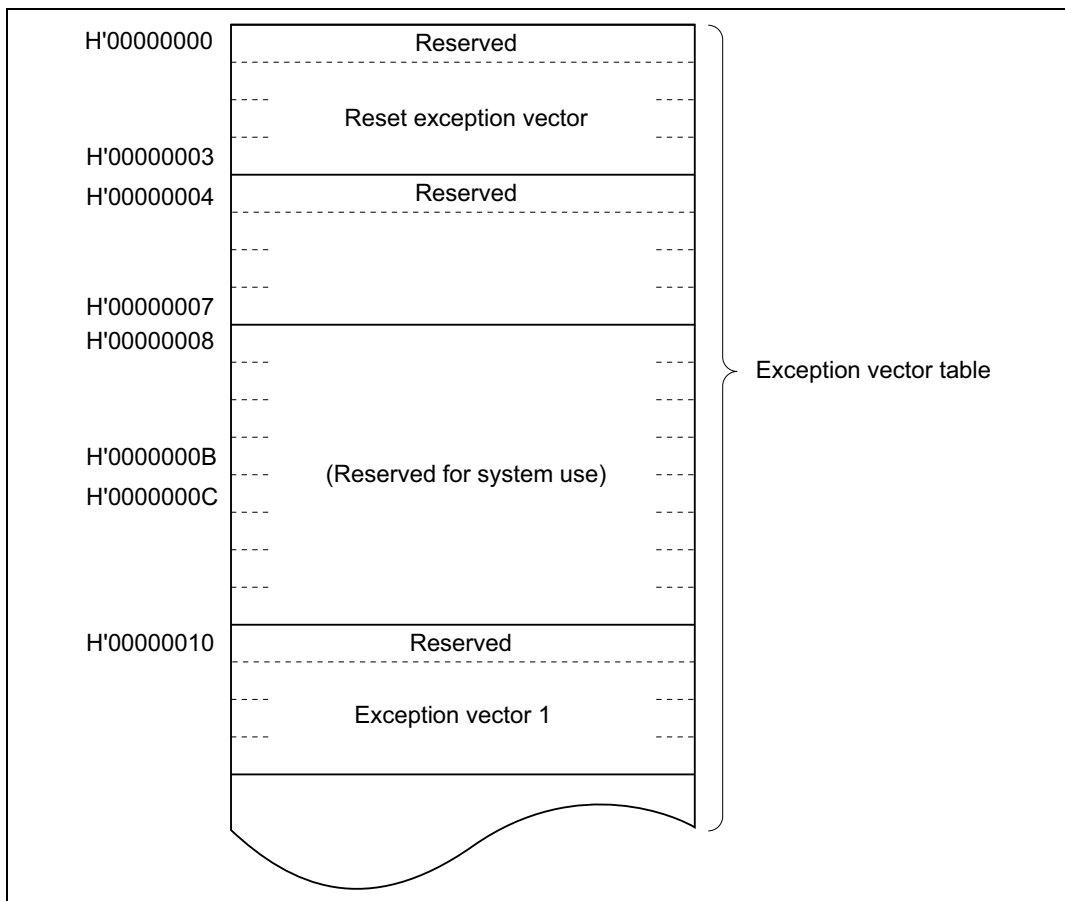

Figure 2-4 Exception Vector Table (Advanced Mode)

The memory indirect addressing mode (@@aa:8) employed in the JMP and JSR instructions uses an 8-bit absolute address included in the instruction code to specify a memory operand that contains a branch address. In advanced mode the operand is a 32-bit longword operand, providing a 32-bit branch address. The upper 8 bits of these 32 bits are a reserved area that is regarded as H'00. Branch addresses can be stored in the area from H'00000000 to H'000000FF. Note that the first part of this range is also the exception vector table.

Stack Structure: In advanced mode, when the program counter (PC) is pushed onto the stack in a subroutine call, and the PC, condition-code register (CCR), and extended control register (EXR) are pushed onto the stack in exception handling, they are stored as shown in figure 2-5. When EXR is invalid, it is not pushed onto the stack. For details, see section 4, Exception Handling.

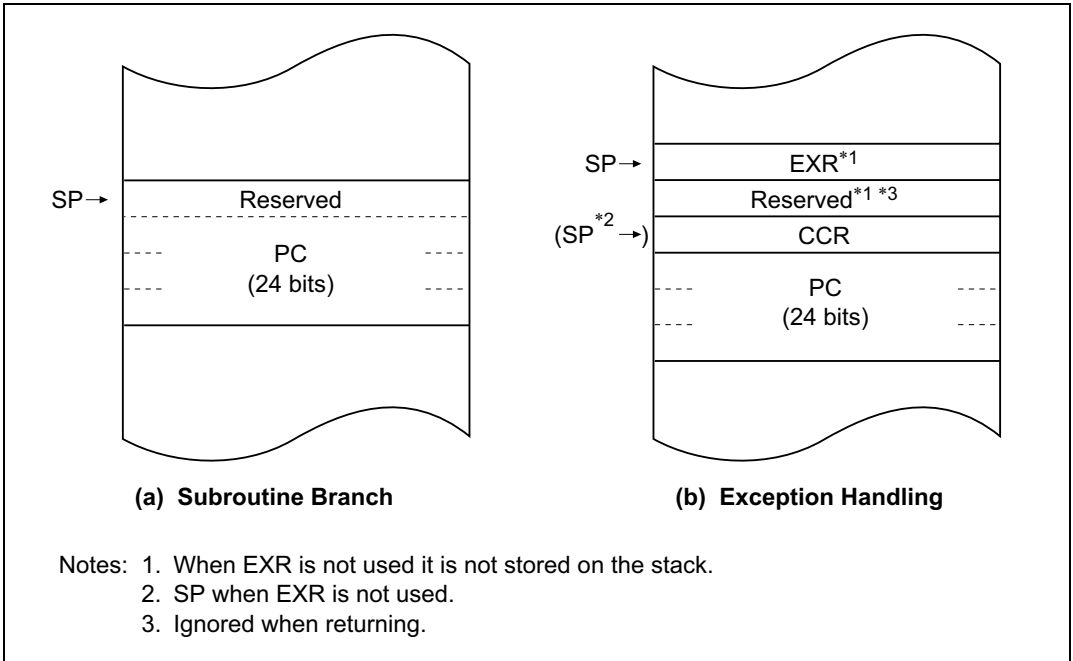

Figure 2-5 Stack Structure in Advanced Mode

2.3 Address Space

Figure 2-6 shows a memory map of the H8S/2600 CPU. The H8S/2600 CPU provides linear access to a maximum 64-kbyte address space in normal mode, and a maximum 16-Mbyte (architecturally 4-Gbyte) address space in advanced mode.

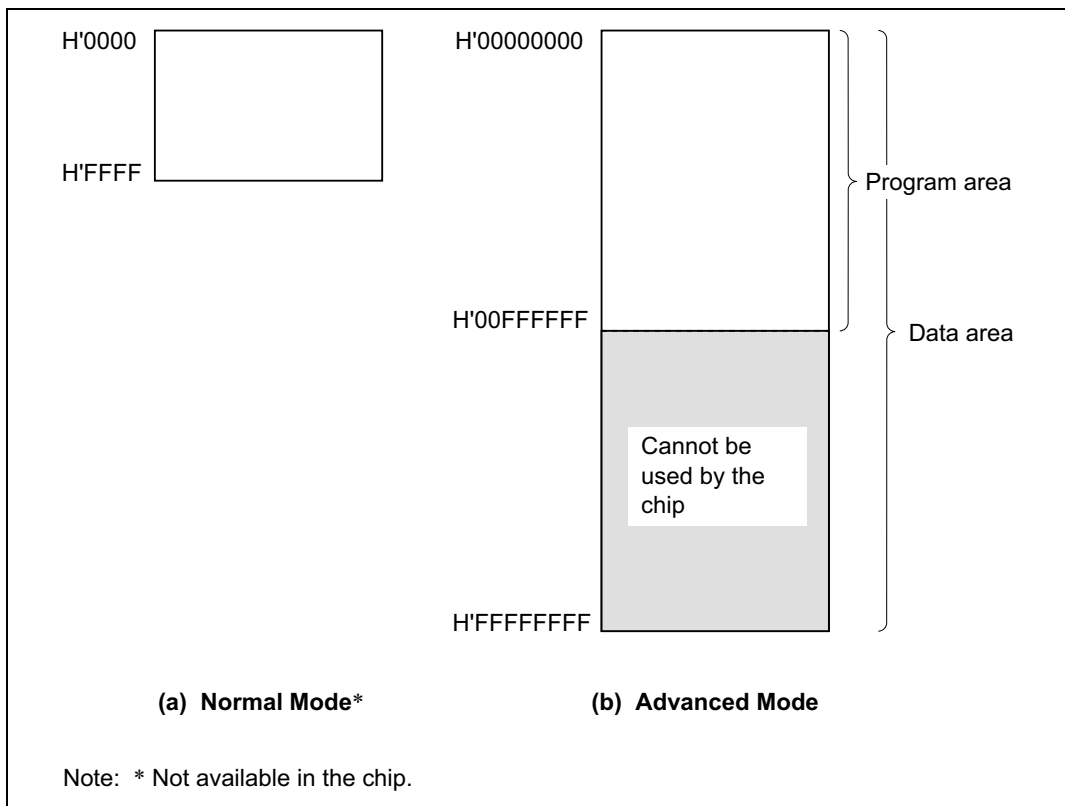

Figure 2-6 Memory Map

2.4 Register Configuration

2.4.1 Overview

The CPU has the internal registers shown in figure 2-7. There are two types of registers: general registers and control registers.

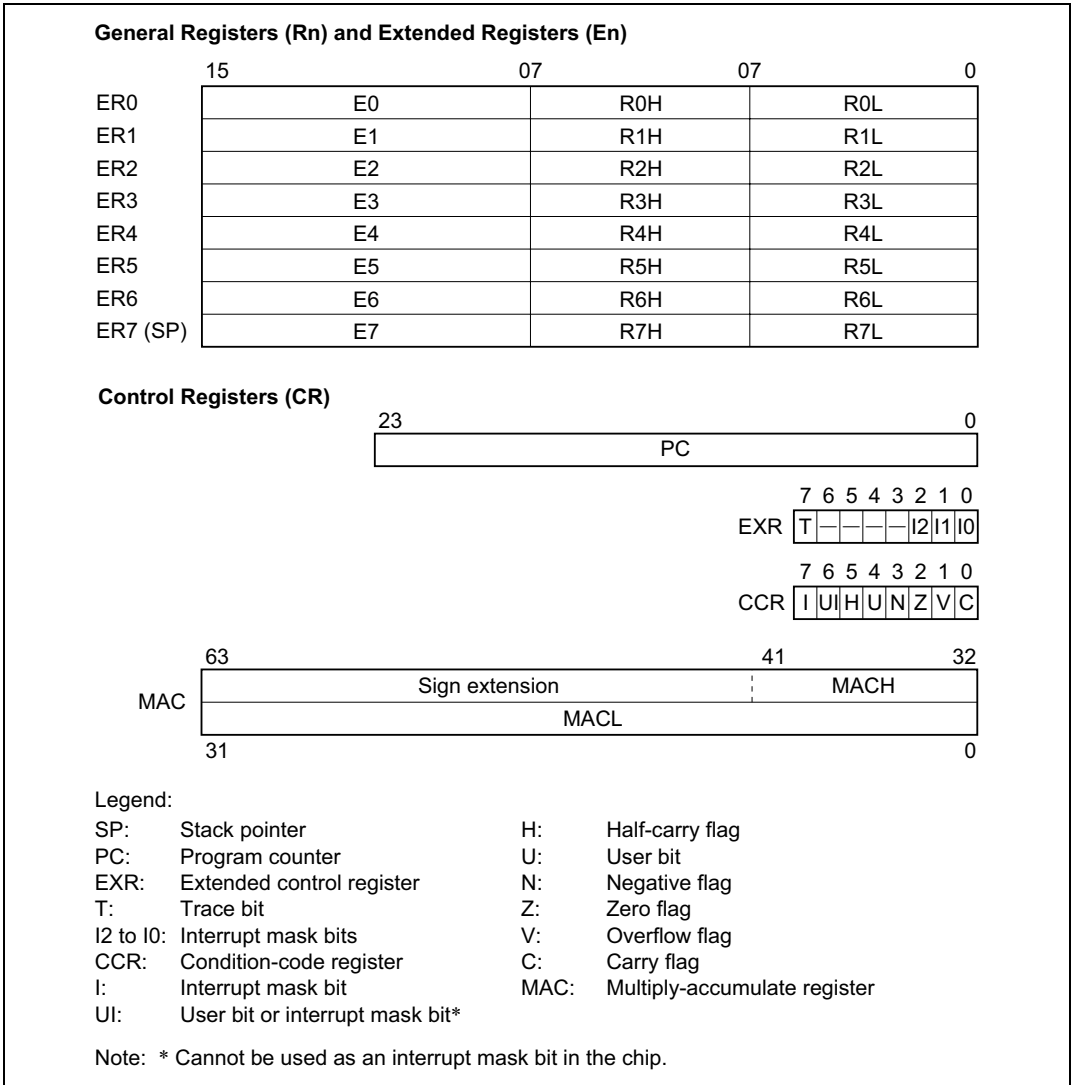

Figure 2-7 CPU Registers

2.4.2 General Registers

The CPU has eight 32-bit general registers. These general registers are all functionally alike and can be used as both address registers and data registers. When a general register is used as a data register, it can be accessed as a 32-bit, 16-bit, or 8-bit register. When the general registers are used as 32-bit registers or address registers, they are designated by the letters ER (ER0 to ER7).

The ER registers divide into 16-bit general registers designated by the letters E (E0 to E7) and R (R0 to R7). These registers are functionally equivalent, providing a maximum sixteen 16-bit registers. The E registers (E0 to E7) are also referred to as extended registers.

The R registers divide into 8-bit general registers designated by the letters RH (R0H to R7H) and RL (R0L to R7L). These registers are functionally equivalent, providing a maximum sixteen 8-bit registers.

Figure 2-8 illustrates the usage of the general registers. The usage of each register can be selected independently.

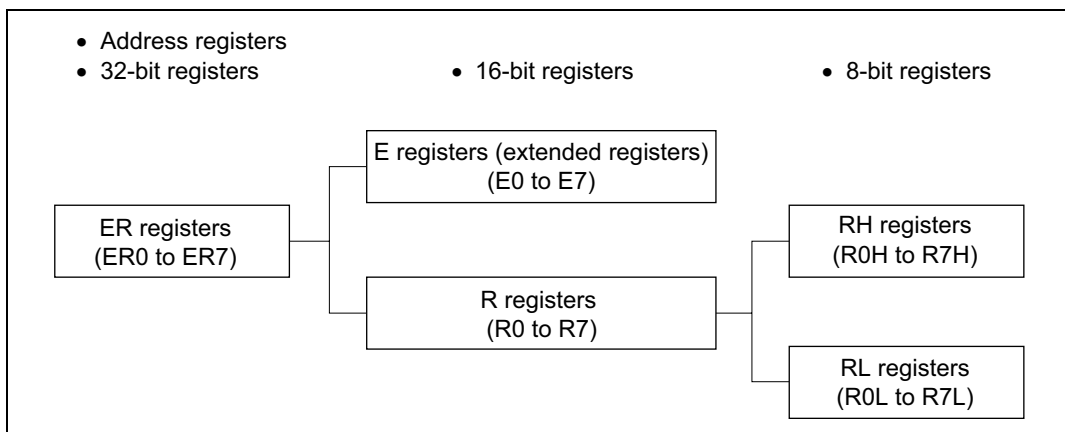

Figure 2-8 Usage of General Registers

General register ER7 has the function of stack pointer (SP) in addition to its general-register function, and is used implicitly in exception handling and subroutine calls. Figure 2-9 shows the stack.

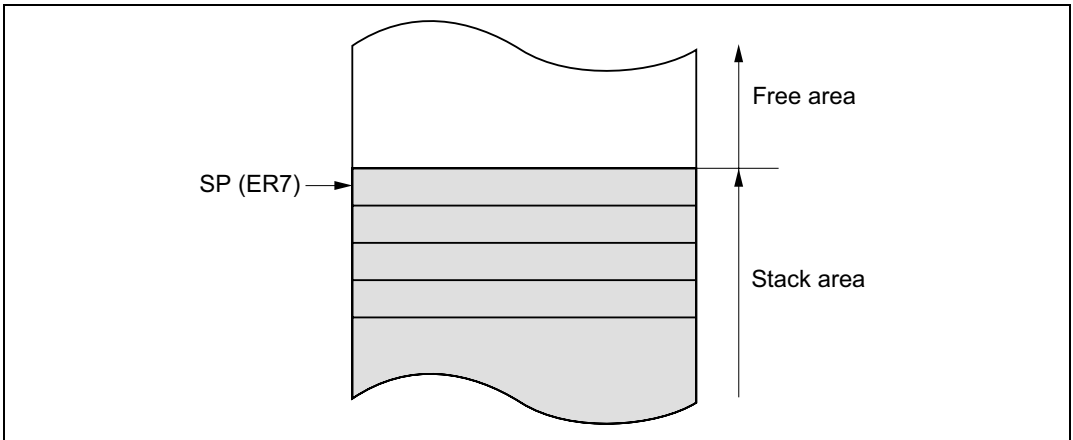

Figure 2-9 Stack

2.4.3 Control Registers

The control registers are the 24-bit program counter (PC), 8-bit extended control register (EXR), 8-bit condition-code register (CCR), and 64-bit multiply-accumulate register (MAC).

(1) Program Counter (PC)

This 24-bit counter indicates the address of the next instruction the CPU will execute. The length of all CPU instructions is 2 bytes (one word), so the least significant PC bit is ignored (When an instruction is fetched, the least significant PC bit is regarded as 0).

(2) Extended Control Register (EXR)

This 8-bit register contains the trace bit (T) and three interrupt mask bits (I2 to I0).

Bit 7—Trace Bit (T): Selects trace mode. When this bit is cleared to 0, instructions are executed in sequence. When this bit is set to 1, a trace exception is generated each time an instruction is executed.

Bits 6 to 3—Reserved: These bits are reserved. They are always read as 1.

Bits 2 to 0—Interrupt Mask Bits (I2 to I0): These bits designate the interrupt mask level (0 to 7). For details, refer to section 5, Interrupt Controller.

Operations can be performed on the EXR bits by the LDC, STC, ANDC, ORC, and XORC instructions. All interrupts, including NMI, are disabled for three states after one of these instructions is executed, except for STC.

(3) Condition-Code Register (CCR)

This 8-bit register contains internal CPU status information, including an interrupt mask bit (I) and half-carry (H), negative (N), zero (Z), overflow (V), and carry (C) flags.

Bit 7—Interrupt Mask Bit (I): Masks interrupts other than NMI when set to 1 (NMI is accepted regardless of the I bit setting). The I bit is set to 1 by hardware at the start of an exception-handling sequence. For details, refer to section 5, Interrupt Controller.

Bit 6—User Bit or Interrupt Mask Bit (UI): Can be written and read by software using the LDC, STC, ANDC, ORC, and XORC instructions. This bit can also be used as an interrupt mask bit. For details, refer to section 5, Interrupt Controller.

Bit 5—Half-Carry Flag (H): When the ADD.B, ADDX.B, SUB.B, SUBX.B, CMP.B, or NEG.B instruction is executed, this flag is set to 1 if there is a carry or borrow at bit 3, and cleared to 0 otherwise. When the ADD.W, SUB.W, CMP.W, or NEG.W instruction is executed, the H flag is set to 1 if there is a carry or borrow at bit 11, and cleared to 0 otherwise. When the ADD.L, SUB.L, CMP.L, or NEG.L instruction is executed, the H flag is set to 1 if there is a carry or borrow at bit 27, and cleared to 0 otherwise.

Bit 4—User Bit (U): Can be written and read by software using the LDC, STC, ANDC, ORC, and XORC instructions.

Bit 3—Negative Flag (N): Stores the value of the most significant bit (sign bit) of data.

Bit 2—Zero Flag (Z): Set to 1 to indicate zero data, and cleared to 0 to indicate non-zero data.

Bit 1—Overflow Flag (V): Set to 1 when an arithmetic overflow occurs, and cleared to 0 at other times.

Bit 0—Carry Flag (C): Set to 1 when a carry occurs, and cleared to 0 otherwise. Used by:

- Add instructions, to indicate a carry
- Subtract instructions, to indicate a borrow
- Shift and rotate instructions, to store the value shifted out of the end bit

The carry flag is also used as a bit accumulator by bit manipulation instructions.

Some instructions leave some or all of the flag bits unchanged. For the action of each instruction on the flag bits, refer to Appendix A.1, List of Instructions.

Operations can be performed on the CCR bits by the LDC, STC, ANDC, ORC, and XORC instructions. The N, Z, V, and C flags are used as branching conditions for conditional branch (Bcc) instructions.

(4) Multiply-Accumulate Register (MAC)

This 64-bit register stores the results of multiply-and-accumulate operations. It consists of two 32-bit registers denoted MACH and MACL. The lower 10 bits of MACH are valid; the upper bits are a sign extension.

2.4.4 Initial Register Values

Reset exception handling loads the CPU's program counter (PC) from the vector table, clears the trace bit in EXR to 0, and sets the interrupt mask bits in CCR and EXR to 1. The other CCR bits and the general registers are not initialized. In particular, the stack pointer (ER7) is not initialized. The stack pointer should therefore be initialized by an MOV.L instruction executed immediately after a reset.

2.5 Data Formats

The CPU can process 1-bit, 4-bit (BCD), 8-bit (byte), 16-bit (word), and 32-bit (longword) data. Bit-manipulation instructions operate on 1-bit data by accessing bit n ($n = 0, 1, 2, \dots, 7$) of byte operand data. The DAA and DAS decimal-adjust instructions treat byte data as two digits of 4-bit BCD data.

2.5.1 General Register Data Formats

Figure 2-10 shows the data formats in general registers.

Data Type	Register Number	Data Format
1-bit data	RnH	
1-bit data	RnL	
4-bit BCD data	RnH	
4-bit BCD data	RnL	
Byte data	RnH	
Byte data	RnL	

Figure 2-10 General Register Data Formats

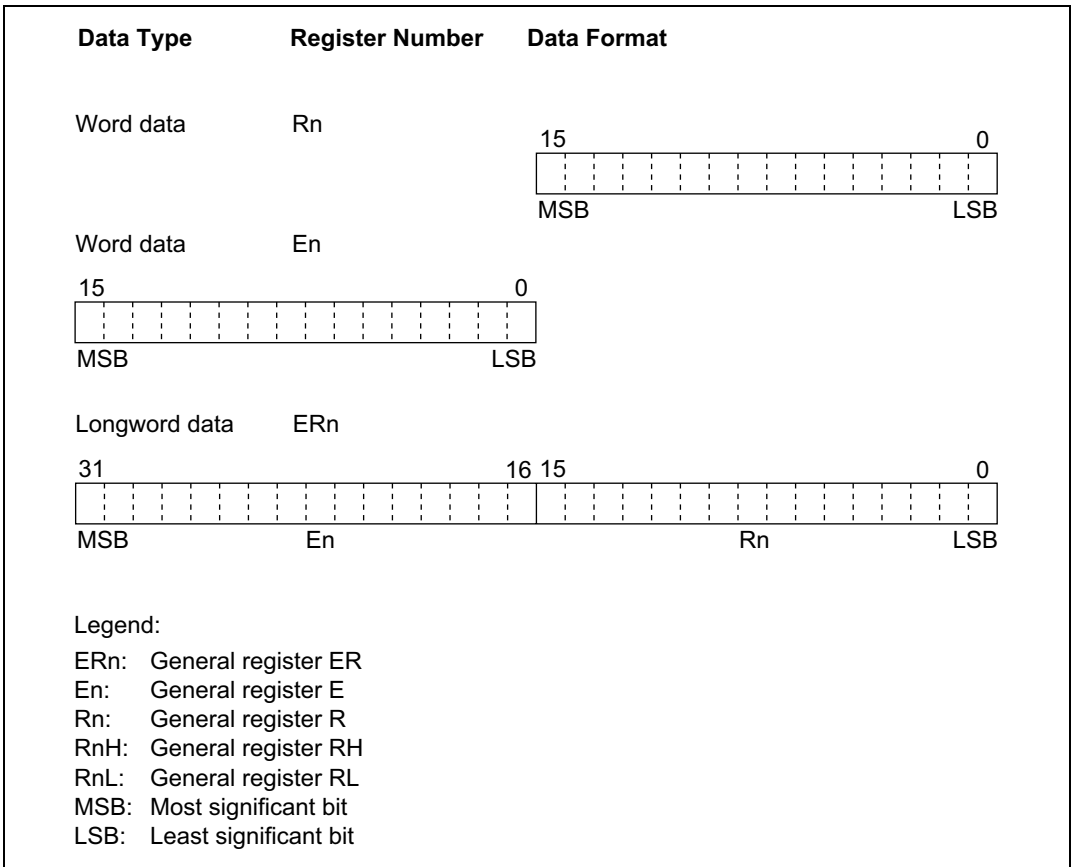

Figure 2-10 General Register Data Formats (cont)

2.5.2 Memory Data Formats

Figure 2-11 shows the data formats in memory. The CPU can access word data and longword data in memory, but word or longword data must begin at an even address. If an attempt is made to access word or longword data at an odd address, no address error occurs but the least significant bit of the address is regarded as 0, so the access starts at the preceding address. This also applies to instruction fetches.

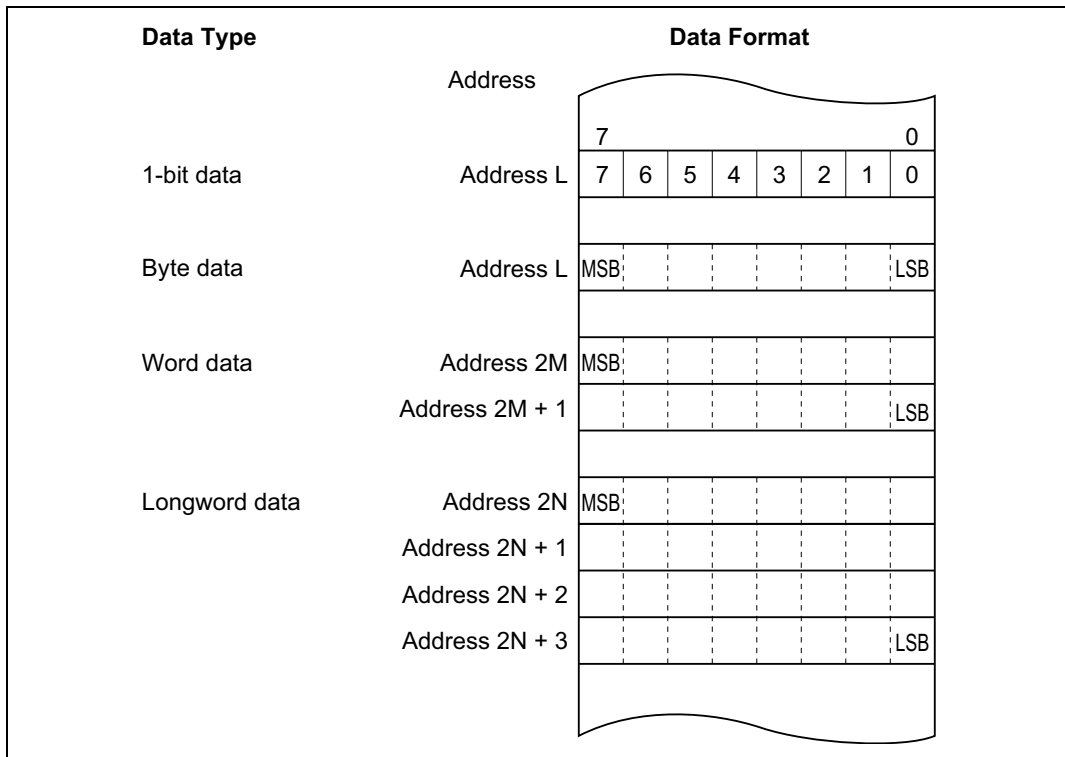

Figure 2-11 Memory Data Formats

When ER7 is used as an address register to access the stack, the operand size should be word size or longword size.

2.6 Instruction Set

2.6.1 Overview

The H8S/2600 CPU has 69 types of instructions. The instructions are classified by function in table 2-1.

Table 2-1 Instruction Classification

Function	Instructions	Size	Types
Data transfer	MOV	BWL	5
	POP ^{*1} , PUSH ^{*1}	WL	
	LDM ^{*5} , STM ^{*5}	L	
	MOVFPE ^{*3} , MOVTPPE ^{*3}	B	
Arithmetic operations	ADD, SUB, CMP, NEG	BWL	23
	ADDX, SUBX, DAA, DAS	B	
	INC, DEC	BWL	
	ADDS, SUBS	L	
	MULXU, DIVXU, MULXS, DIVXS	BW	
	EXTU, EXTS	WL	
	TAS ^{*4}	B	
	MAC, LDMAC, STMAC, CLRMAC	—	
Logic operations	AND, OR, XOR, NOT	BWL	4
Shift	SHAL, SHAR, SHLL, SHLR, ROTL, ROTR, ROTXL, ROTXR	BWL	8
Bit manipulation	BSET, BCLR, BNOT, BTST, BLD, BILD, BST, BIST, BAND, BIAND, BOR, BIOR, BXOR, BIXOR	B	14
Branch	Bcc ^{*2} , JMP, BSR, JSR, RTS	—	5
System control	TRAPA, RTE, SLEEP, LDC, STC, ANDC, ORC, XORC, NOP	—	9
Block data transfer	EPEMOV	—	1

Total: 69 types

Legend:

B: Byte

W: Word

L: Longword

- Notes: 1. POP.W Rn and PUSH.W Rn are identical to MOV.W @SP+, Rn and MOV.W Rn, @-SP. POP.L ERn and PUSH.L ERn are identical to MOV.L @SP+, ERn and MOV.L ERn, @-SP.
2. Bcc is the general name for conditional branch instructions.
3. Not available in the chip.
4. Only register ER0, ER1, ER4, or ER5 should be used when using the TAS instruction.
5. Only registers ER0 to ER6 should be used when using the STM/LDM instruction.

2.6.3 Table of Instructions Classified by Function

Table 2-3 summarizes the instructions in each functional category. The notation used in table 2-3 is defined below.

Operation Notation

Rd	General register (destination)*
Rs	General register (source)*
Rn	General register*
ERn	General register (32-bit register)
MAC	Multiply-accumulate register (32-bit register)
(EAd)	Destination operand
(EAs)	Source operand
EXR	Extended control register
CCR	Condition-code register
N	N (negative) flag in CCR
Z	Z (zero) flag in CCR
V	V (overflow) flag in CCR
C	C (carry) flag in CCR
PC	Program counter
SP	Stack pointer
#IMM	Immediate data
disp	Displacement
+	Addition
-	Subtraction
×	Multiplication
÷	Division
^	Logical AND
∨	Logical OR
⊕	Logical exclusive OR
→	Move
¬	NOT (logical complement)
:8/:16/:24/:32	8-, 16-, 24-, or 32-bit length

Note: * General registers include 8-bit registers (R0H to R7H, R0L to R7L), 16-bit registers (R0 to R7, E0 to E7), and 32-bit registers (ER0 to ER7).

Table 2-3 Instructions Classified by Function

Type	Instruction	Size*¹	Function
Data transfer	MOV	B/W/L	(EAs) → Rd, Rs → (EAd) Moves data between two general registers or between a general register and memory, or moves immediate data to a general register.
	MOVFPE	B	Cannot be used in this LSI.
	MOVTPE	B	Cannot be used in this LSI.
	POP	W/L	@SP+ → Rn Pops a register from the stack. POP.W Rn is identical to MOV.W @SP+, Rn. POP.L ERn is identical to MOV.L @SP+, ERn.
	PUSH	W/L	Rn → @-SP Pushes a register onto the stack. PUSH.W Rn is identical to MOV.W Rn, @-SP. PUSH.L ERn is identical to MOV.L ERn, @-SP.
	LDM* ²	L	@SP+ → Rn (register list) Pops two or more general registers from the stack.
	STM* ²	L	Rn (register list) → @-SP Pushes two or more general registers onto the stack.

Type	Instruction	Size ^{*1}	Function
Arithmetic operations	ADD	B/W/L	$Rd \pm Rs \rightarrow Rd, Rd \pm \#IMM \rightarrow Rd$
	SUB		Performs addition or subtraction on data in two general registers, or on immediate data and data in a general register (Immediate byte data cannot be subtracted from byte data in a general register. Use the SUBX or ADD instruction).
	ADDX SUBX	B	$Rd \pm Rs \pm C \rightarrow Rd, Rd \pm \#IMM \pm C \rightarrow Rd$ Performs addition or subtraction with carry or borrow on byte data in two general registers, or on immediate data and data in a general register.
	INC DEC	B/W/L	$Rd \pm 1 \rightarrow Rd, Rd \pm 2 \rightarrow Rd$ Increments or decrements a general register by 1 or 2 (Byte operands can be incremented or decremented by 1 only).
	ADDS SUBS	L	$Rd \pm 1 \rightarrow Rd, Rd \pm 2 \rightarrow Rd, Rd \pm 4 \rightarrow Rd$ Adds or subtracts the value 1, 2, or 4 to or from data in a 32-bit register.
	DAA DAS	B	$Rd \text{ decimal adjust} \rightarrow Rd$ Decimal-adjusts an addition or subtraction result in a general register by referring to the CCR to produce 4-bit BCD data.
	MULXU	B/W	$Rd \times Rs \rightarrow Rd$ Performs unsigned multiplication on data in two general registers: either 8 bits \times 8 bits \rightarrow 16 bits or 16 bits \times 16 bits \rightarrow 32 bits.
	MULXS	B/W	$Rd \times Rs \rightarrow Rd$ Performs signed multiplication on data in two general registers: either 8 bits \times 8 bits \rightarrow 16 bits or 16 bits \times 16 bits \rightarrow 32 bits.
	DIVXU	B/W	$Rd \div Rs \rightarrow Rd$ Performs unsigned division on data in two general registers: either 16 bits \div 8 bits \rightarrow 8-bit quotient and 8-bit remainder or 32 bits \div 16 bits \rightarrow 16-bit quotient and 16-bit remainder.

Type	Instruction	Size*1	Function
Arithmetic operations	DIVXS	B/W	$Rd \div Rs \rightarrow Rd$ Performs signed division on data in two general registers: either 16 bits \div 8 bits \rightarrow 8-bit quotient and 8-bit remainder or 32 bits \div 16 bits \rightarrow 16-bit quotient and 16-bit remainder.
	CMP	B/W/L	$Rd - Rs, Rd - \#IMM$ Compares data in a general register with data in another general register or with immediate data, and sets CCR bits according to the result.
	NEG	B/W/L	$0 - Rd \rightarrow Rd$ Takes the two's complement (arithmetic complement) of data in a general register.
	EXTU	W/L	Rd (zero extension) $\rightarrow Rd$ Extends the lower 8 bits of a 16-bit register to word size, or the lower 16 bits of a 32-bit register to longword size, by padding with zeros on the left.
	EXTS	W/L	Rd (sign extension) $\rightarrow Rd$ Extends the lower 8 bits of a 16-bit register to word size, or the lower 16 bits of a 32-bit register to longword size, by extending the sign bit.
	TAS	B	$@ERd - 0, 1 \rightarrow (<bit 7> \text{ of } @ERd)^{*3}$ Tests memory contents, and sets the most significant bit (bit 7) to 1.
	MAC	—	$(EAs) \times (EAd) + MAC \rightarrow MAC$ Performs signed multiplication on memory contents and adds the result to the multiply-accumulate register. The following operations can be performed: 16 bits \times 16 bits + 32 bits \rightarrow 32 bits, saturating 16 bits \times 16 bits + 42 bits \rightarrow 42 bits, non-saturating
	CLRMAC	—	$0 \rightarrow MAC$ Clears the multiply-accumulate register to zero.
	LDMAC STMAC	L	$Rs \rightarrow MAC, MAC \rightarrow Rd$ Transfers data between a general register and a multiply-accumulate register.

Type	Instruction	Size*1	Function
Logic operations	AND	B/W/L	$Rd \wedge Rs \rightarrow Rd$, $Rd \wedge \#IMM \rightarrow Rd$ Performs a logical AND operation on a general register and another general register or immediate data.
	OR	B/W/L	$Rd \vee Rs \rightarrow Rd$, $Rd \vee \#IMM \rightarrow Rd$ Performs a logical OR operation on a general register and another general register or immediate data.
	XOR	B/W/L	$Rd \oplus Rs \rightarrow Rd$, $Rd \oplus \#IMM \rightarrow Rd$ Performs a logical exclusive OR operation on a general register and another general register or immediate data.
	NOT	B/W/L	$\neg (Rd) \rightarrow (Rd)$ Takes the one's complement of general register contents.
Shift operations	SHAL SHAR	B/W/L	$Rd \text{ (shift)} \rightarrow Rd$ Performs an arithmetic shift on general register contents. 1-bit or 2-bit shift is possible.
	SHLL SHLR	B/W/L	$Rd \text{ (shift)} \rightarrow Rd$ Performs a logical shift on general register contents. 1-bit or 2-bit shift is possible.
	ROTL ROTR	B/W/L	$Rd \text{ (rotate)} \rightarrow Rd$ Rotates general register contents. 1-bit or 2-bit rotation is possible.
	ROTXL ROTXR	B/W/L	$Rd \text{ (rotate)} \rightarrow Rd$ Rotates general register contents through the carry flag. 1-bit or 2-bit rotation is possible.

Type	Instruction	Size*1	Function
Bit-manipulation instructions	BSET	B	$1 \rightarrow (\text{<bit-No.> of <EAd>})$ Sets a specified bit in a general register or memory operand to 1. The bit number is specified by 3-bit immediate data or the lower three bits of a general register.
	BCLR	B	$0 \rightarrow (\text{<bit-No.> of <EAd>})$ Clears a specified bit in a general register or memory operand to 0. The bit number is specified by 3-bit immediate data or the lower three bits of a general register.
	BNOT	B	$\neg (\text{<bit-No.> of <EAd>}) \rightarrow (\text{<bit-No.> of <EAd>})$ Inverts a specified bit in a general register or memory operand. The bit number is specified by 3-bit immediate data or the lower three bits of a general register.
	BTST	B	$\neg (\text{<bit-No.> of <EAd>}) \rightarrow Z$ Tests a specified bit in a general register or memory operand and sets or clears the Z flag accordingly. The bit number is specified by 3-bit immediate data or the lower three bits of a general register.
	BAND	B	$C \wedge (\text{<bit-No.> of <EAd>}) \rightarrow C$ ANDs the carry flag with a specified bit in a general register or memory operand and stores the result in the carry flag.
	BIAND	B	$C \wedge [\neg (\text{<bit-No.> of <EAd>})] \rightarrow C$ ANDs the carry flag with the inverse of a specified bit in a general register or memory operand and stores the result in the carry flag. The bit number is specified by 3-bit immediate data.
	BOR	B	$C \vee (\text{<bit-No.> of <EAd>}) \rightarrow C$ ORs the carry flag with a specified bit in a general register or memory operand and stores the result in the carry flag.
	BIOR	B	$C \vee \neg (\text{<bit-No.> of <EAd>}) \rightarrow C$ ORs the carry flag with the inverse of a specified bit in a general register or memory operand and stores the result in the carry flag. The bit number is specified by 3-bit immediate data.

Type	Instruction	Size*1	Function
Bit-manipulation instructions	BXOR	B	$C \oplus (\text{<bit-No.> of <EAd>}) \rightarrow C$ Exclusive-ORs the carry flag with a specified bit in a general register or memory operand and stores the result in the carry flag.
	BIXOR	B	$C \oplus \neg [(\text{<bit-No.> of <EAd>})] \rightarrow C$ Exclusive-ORs the carry flag with the inverse of a specified bit in a general register or memory operand and stores the result in the carry flag. The bit number is specified by 3-bit immediate data.
	BLD	B	$(\text{<bit-No.> of <EAd>}) \rightarrow C$ Transfers a specified bit in a general register or memory operand to the carry flag.
	BILD	B	$\neg (\text{<bit-No.> of <EAd>}) \rightarrow C$ Transfers the inverse of a specified bit in a general register or memory operand to the carry flag. The bit number is specified by 3-bit immediate data.
	BST	B	$C \rightarrow (\text{<bit-No.> of <EAd>})$ Transfers the carry flag value to a specified bit in a general register or memory operand.
	BIST	B	$\neg C \rightarrow (\text{<bit-No.> of <EAd>})$ Transfers the inverse of the carry flag value to a specified bit in a general register or memory operand. The bit number is specified by 3-bit immediate data.

Type	Instruction	Size*1	Function		
Branch instructions	Bcc	—	Branches to a specified address if a specified condition is true. The branching conditions are listed below.		
			Mnemonic	Description	Condition
			BRA(BT)	Always (true)	Always
			BRN(BF)	Never (false)	Never
			BHI	High	$C \vee Z = 0$
			BLS	Low or same	$C \vee Z = 1$
			BCC(BHS)	Carry clear (high or same)	$C = 0$
			BCS(BLO)	Carry set (low)	$C = 1$
			BNE	Not equal	$Z = 0$
			BEQ	Equal	$Z = 1$
			BVC	Overflow clear	$V = 0$
			BVS	Overflow set	$V = 1$
			BPL	Plus	$N = 0$
			BMI	Minus	$N = 1$
			BGE	Greater or equal	$N \oplus V = 0$
			BLT	Less than	$N \oplus V = 1$
			BGT	Greater than	$Z \vee (N \oplus V) = 0$
BLE	Less or equal	$Z \vee (N \oplus V) = 1$			
JMP	—	Branches unconditionally to a specified address.			
BSR	—	Branches to a subroutine at a specified address.			
JSR	—	Branches to a subroutine at a specified address.			
RTS	—	Returns from a subroutine			

Type	Instruction	Size*1	Function
System control instructions	TRAPA	—	Starts trap-instruction exception handling.
	RTE	—	Returns from an exception-handling routine.
	SLEEP	—	Causes a transition to a power-down state.
	LDC	B/W	(EAs) → CCR, (EAs) → EXR Moves the source operand contents or immediate data to CCR or EXR. Although CCR and EXR are 8-bit registers, word-size transfers are performed between them and memory. The upper 8 bits are valid.
	STC	B/W	CCR → (EAd), EXR → (EAd) Transfers CCR or EXR contents to a general register or memory. Although CCR and EXR are 8-bit registers, word-size transfers are performed between them and memory. The upper 8 bits are valid.
	ANDC	B	CCR ∧ #IMM → CCR, EXR ∧ #IMM → EXR Logically ANDs the CCR or EXR contents with immediate data.
	ORC	B	CCR ∨ #IMM → CCR, EXR ∨ #IMM → EXR Logically ORs the CCR or EXR contents with immediate data.
	XORC	B	CCR ⊕ #IMM → CCR, EXR ⊕ #IMM → EXR Logically exclusive-ORs the CCR or EXR contents with immediate data.
NOP	—	PC + 2 → PC Only increments the program counter.	

Type	Instruction	Size* ¹	Function
Block data transfer instruction	EEPMOV.B	—	if R4L ≠ 0 then Repeat @ER5+ → @ER6+ R4L-1 → R4L Until R4L = 0 else next;
	EEPMOV.W	—	if R4 ≠ 0 then Repeat @ER5+ → @ER6+ R4-1 → R4 Until R4 = 0 else next;
			Transfers a data block according to parameters set in general registers R4L or R4, ER5, and ER6. R4L or R4: size of block (bytes) ER5: starting source address ER6: starting destination address Execution of the next instruction begins as soon as the transfer is completed.

Notes: 1. Size refers to the operand size.

B: Byte

W: Word

L: Longword

2. Only registers ER0 to ER6 should be used when using the STM/LDM instruction.

3. Only register ER0, ER1, ER4, or ER5 should be used when using the TAS instruction.

2.6.4 Basic Instruction Formats

The CPU instructions consist of 2-byte (1-word) units. An instruction consists of an operation field (op field), a register field (r field), an effective address extension (EA field), and a condition field (cc).

(1) Operation Field: Indicates the function of the instruction, the addressing mode, and the operation to be carried out on the operand. The operation field always includes the first four bits of the instruction. Some instructions have two operation fields.

(2) Register Field: Specifies a general register. Address registers are specified by 3 bits, data registers by 3 bits or 4 bits. Some instructions have two register fields. Some have no register field.

(3) Effective Address Extension: Eight, 16, or 32 bits specifying immediate data, an absolute address, or a displacement.

(4) **Condition Field:** Specifies the branching condition of Bcc instructions.

Figure 2-12 shows examples of instruction formats.

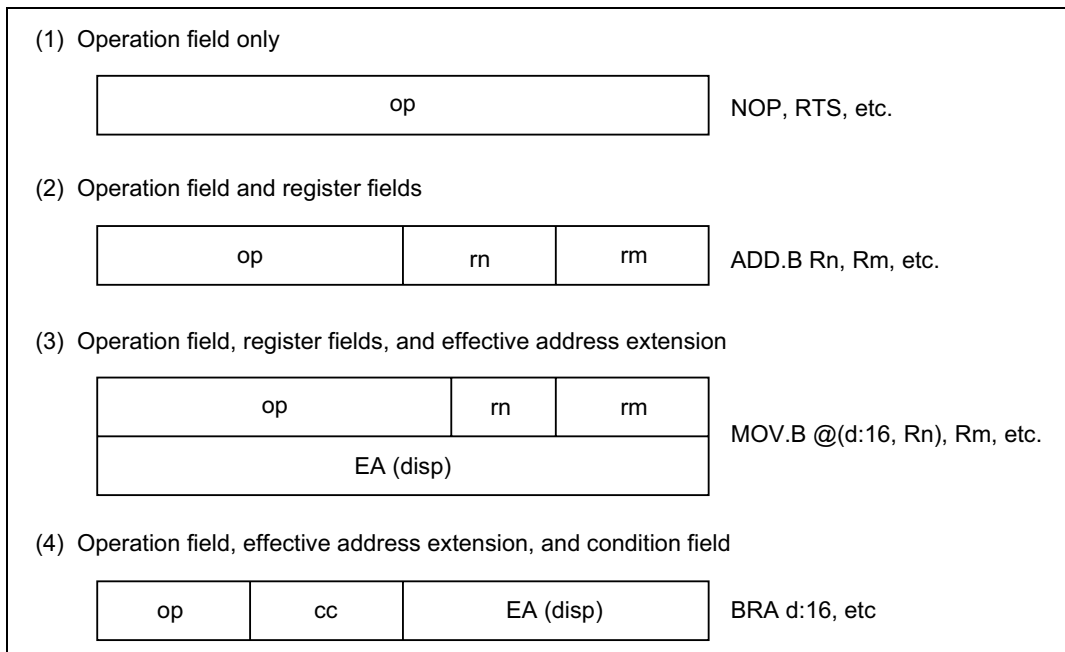

Figure 2-12 Instruction Formats (Examples)

2.7 Addressing Modes and Effective Address Calculation

2.7.1 Addressing Mode

The CPU supports the eight addressing modes listed in table 2-4. Each instruction uses a subset of these addressing modes. Arithmetic and logic instructions can use the register direct and immediate modes. Data transfer instructions can use all addressing modes except program-counter relative and memory indirect. Bit manipulation instructions use register direct, register indirect, or absolute addressing mode to specify an operand, and register direct (BSET, BCLR, BNOT, and BTST instructions) or immediate (3-bit) addressing mode to specify a bit number in the operand.

Table 2-4 Addressing Modes

No.	Addressing Mode	Symbol
1	Register direct	Rn
2	Register indirect	@ERn
3	Register indirect with displacement	@(d:16,ERn)/@(d:32,ERn)
4	Register indirect with post-increment Register indirect with pre-decrement	@ERn+ @-ERn
5	Absolute address	@aa:8/@aa:16/@aa:24/@aa:32
6	Immediate	#xx:8/#xx:16/#xx:32
7	Program-counter relative	@(d:8,PC)/@(d:16,PC)
8	Memory indirect	@@aa:8

(1) **Register Direct**—**Rn**: The register field of the instruction specifies an 8-, 16-, or 32-bit general register containing the operand. R0H to R7H and R0L to R7L can be specified as 8-bit registers. R0 to R7 and E0 to E7 can be specified as 16-bit registers. ER0 to ER7 can be specified as 32-bit registers.

(2) **Register Indirect**—**@ERn**: The register field of the instruction code specifies an address register (ERn) which contains the address of the operand on memory. If the address is a program instruction address, the lower 24 bits are valid and the upper 8 bits are all assumed to be 0 (H'00).

(3) **Register Indirect with Displacement**—**@(d:16, ERn)** or **@(d:32, ERn)**: A 16-bit or 32-bit displacement contained in the instruction is added to an address register (ERn) specified by the register field of the instruction, and the sum gives the address of a memory operand. A 16-bit displacement is sign-extended when added.

(4) Register Indirect with Post-Increment or Pre-Decrement—@ERn+ or @-ERn:

- Register indirect with post-increment—@ERn+
The register field of the instruction code specifies an address register (ERn) which contains the address of a memory operand. After the operand is accessed, 1, 2, or 4 is added to the address register contents and the sum is stored in the address register. The value added is 1 for byte access, 2 for word transfer instruction, or 4 for longword transfer instruction. For word or longword transfer instruction, the register value should be even.
- Register indirect with pre-decrement—@-ERn
The value 1, 2, or 4 is subtracted from an address register (ERn) specified by the register field in the instruction code, and the result becomes the address of a memory operand. The result is also stored in the address register. The value subtracted is 1 for byte access, 2 for word transfer instruction, or 4 for longword transfer instruction. For word or longword transfer instruction, the register value should be even.

(5) Absolute Address—@aa:8, @aa:16, @aa:24, or @aa:32: The instruction code contains the absolute address of a memory operand. The absolute address may be 8 bits long (@aa:8), 16 bits long (@aa:16), 24 bits long (@aa:24), or 32 bits long (@aa:32).

To access data, the absolute address should be 8 bits (@aa:8), 16 bits (@aa:16), or 32 bits (@aa:32) long. For an 8-bit absolute address, the upper 24 bits are all assumed to be 1 (H'FFFF). For a 16-bit absolute address the upper 16 bits are a sign extension. A 32-bit absolute address can access the entire address space.

A 24-bit absolute address (@aa:24) indicates the address of a program instruction. The upper 8 bits are all assumed to be 0 (H'00).

Table 2-5 indicates the accessible absolute address ranges.

Table 2-5 Absolute Address Access Ranges

Absolute Address		Normal Mode*	Advanced Mode
Data address	8 bits (@aa:8)	H'FF00 to H'FFFF	H'FFFF00 to H'FFFFFF
	16 bits (@aa:16)	H'0000 to H'FFFF	H'000000 to H'007FFF, H'FF8000 to H'FFFFFF
	32 bits (@aa:32)		H'000000 to H'FFFFFF
Program instruction address	24 bits (@aa:24)		

Note: * Not available in the chip.

(6) Immediate—#xx:8, #xx:16, or #xx:32: The instruction contains 8-bit (#xx:8), 16-bit (#xx:16), or 32-bit (#xx:32) immediate data as an operand.

The ADDS, SUBS, INC, and DEC instructions contain immediate data implicitly. Some bit manipulation instructions contain 3-bit immediate data in the instruction code, specifying a bit number. The TRAPA instruction contains 2-bit immediate data in its instruction code, specifying a vector address.

(7) Program-Counter Relative—@(d:8, PC) or @(d:16, PC): This mode is used in the Bcc and BSR instructions. An 8-bit or 16-bit displacement contained in the instruction is sign-extended and added to the 24-bit PC contents to generate a branch address. Only the lower 24 bits of this branch address are valid; the upper 8 bits are all assumed to be 0 (H'00). The PC value to which the displacement is added is the address of the first byte of the next instruction, so the possible branching range is -126 to +128 bytes (-63 to +64 words) or -32766 to +32768 bytes (-16383 to +16384 words) from the branch instruction. The resulting value should be an even number.

(8) Memory Indirect—@@aa:8: This mode can be used by the JMP and JSR instructions. The instruction code contains an 8-bit absolute address specifying a memory operand. This memory operand contains a branch address. The upper bits of the absolute address are all assumed to be 0, so the address range is 0 to 255 (H'0000 to H'00FF in normal mode*, H'000000 to H'0000FF in advanced mode). In normal mode* the memory operand is a word operand and the branch address is 16 bits long. In advanced mode the memory operand is a longword operand, the first byte of which is assumed to be all 0 (H'00).

Note that the first part of the address range is also the exception vector area. For further details, refer to section 4, Exception Handling.

Note: * Not available in the chip.

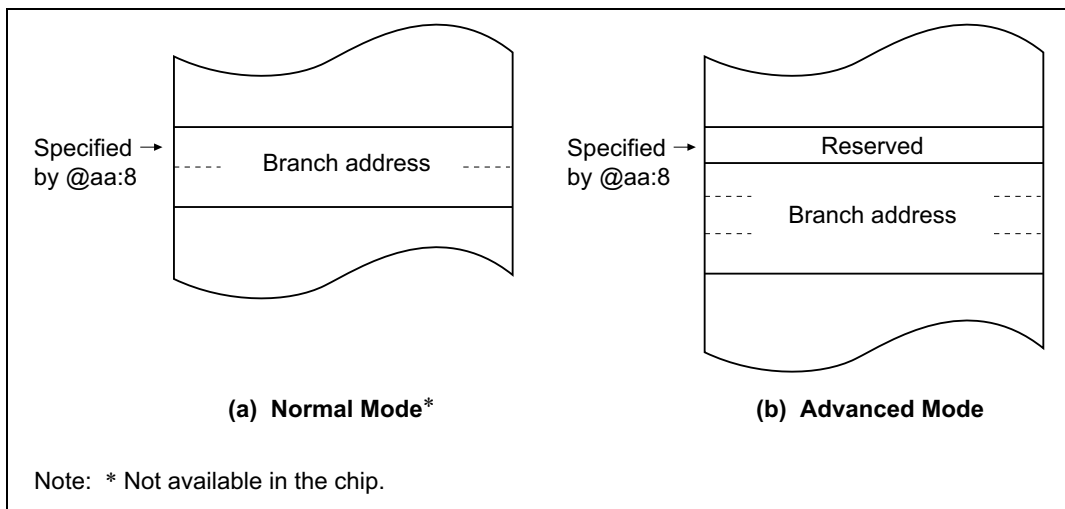

Figure 2-13 Branch Address Specification in Memory Indirect Mode

If an odd address is specified in word or longword memory access, or as a branch address, the least significant bit is regarded as 0, causing data to be accessed or instruction code to be fetched at the address preceding the specified address (For further information, see section 2.5.2, Memory Data Formats).

2.7.2 Effective Address Calculation

Table 2-6 indicates how effective addresses are calculated in each addressing mode. In normal mode* the upper 8 bits of the effective address are ignored in order to generate a 16-bit address.

Note: * Not available in the chip.

Table 2.6 Effective Address Calculation

No.	Addressing Mode and Instruction Format	Effective Address Calculation	Effective Address (EA)																	
1	Register direct (Rn) <div style="border: 1px solid black; padding: 2px; display: inline-block;"> <table style="border-collapse: collapse;"> <tr> <td style="border: 1px solid black; padding: 2px;">op</td> <td style="border: 1px solid black; padding: 2px;">rm</td> <td style="border: 1px solid black; padding: 2px;">rn</td> </tr> </table> </div>	op	rm	rn		Operand is general register contents.														
op	rm	rn																		
2	Register indirect (@ERn) <div style="border: 1px solid black; padding: 2px; display: inline-block;"> <table style="border-collapse: collapse;"> <tr> <td style="border: 1px solid black; padding: 2px;">op</td> <td style="border: 1px solid black; padding: 2px;">r</td> </tr> </table> </div>	op	r	<div style="border: 1px solid black; padding: 2px; display: inline-block;"> <table style="border-collapse: collapse;"> <tr> <td style="border: 1px solid black; padding: 2px;">31</td> <td style="border: 1px solid black; padding: 2px;">General register contents</td> <td style="border: 1px solid black; padding: 2px;">0</td> </tr> </table> </div>	31	General register contents	0	<div style="border: 1px solid black; padding: 2px; display: inline-block;"> <table style="border-collapse: collapse;"> <tr> <td style="border: 1px solid black; padding: 2px;">31</td> <td style="border: 1px solid black; padding: 2px;">Don't care</td> <td style="border: 1px solid black; padding: 2px;">24</td> <td style="border: 1px solid black; padding: 2px;">23</td> <td style="border: 1px solid black; padding: 2px;">0</td> </tr> </table> </div>	31	Don't care	24	23	0							
op	r																			
31	General register contents	0																		
31	Don't care	24	23	0																
3	Register indirect with displacement @(d:16, ERn) or @(d:32, ERn) <div style="border: 1px solid black; padding: 2px; display: inline-block;"> <table style="border-collapse: collapse;"> <tr> <td style="border: 1px solid black; padding: 2px;">op</td> <td style="border: 1px solid black; padding: 2px;">r</td> <td style="border: 1px solid black; padding: 2px;">disp</td> </tr> </table> </div>	op	r	disp	<div style="border: 1px solid black; padding: 2px; display: inline-block;"> <table style="border-collapse: collapse;"> <tr> <td style="border: 1px solid black; padding: 2px;">31</td> <td style="border: 1px solid black; padding: 2px;">General register contents</td> <td style="border: 1px solid black; padding: 2px;">0</td> </tr> </table> </div> <div style="border: 1px solid black; padding: 2px; display: inline-block; margin-top: 5px;"> <table style="border-collapse: collapse;"> <tr> <td style="border: 1px solid black; padding: 2px;">31</td> <td style="border: 1px solid black; padding: 2px;">Sign extension</td> <td style="border: 1px solid black; padding: 2px;">0</td> </tr> <tr> <td style="border: 1px solid black; padding: 2px;"></td> <td style="border: 1px solid black; padding: 2px;">disp</td> <td style="border: 1px solid black; padding: 2px;"></td> </tr> </table> </div>	31	General register contents	0	31	Sign extension	0		disp		<div style="border: 1px solid black; padding: 2px; display: inline-block;"> <table style="border-collapse: collapse;"> <tr> <td style="border: 1px solid black; padding: 2px;">31</td> <td style="border: 1px solid black; padding: 2px;">Don't care</td> <td style="border: 1px solid black; padding: 2px;">24</td> <td style="border: 1px solid black; padding: 2px;">23</td> <td style="border: 1px solid black; padding: 2px;">0</td> </tr> </table> </div>	31	Don't care	24	23	0
op	r	disp																		
31	General register contents	0																		
31	Sign extension	0																		
	disp																			
31	Don't care	24	23	0																
4	Register indirect with post-increment or pre-decrement • Register indirect with post-increment @ERn+ <div style="border: 1px solid black; padding: 2px; display: inline-block;"> <table style="border-collapse: collapse;"> <tr> <td style="border: 1px solid black; padding: 2px;">op</td> <td style="border: 1px solid black; padding: 2px;">r</td> </tr> </table> </div> • Register indirect with pre-decrement @-ERn <div style="border: 1px solid black; padding: 2px; display: inline-block;"> <table style="border-collapse: collapse;"> <tr> <td style="border: 1px solid black; padding: 2px;">op</td> <td style="border: 1px solid black; padding: 2px;">r</td> </tr> </table> </div>	op	r	op	r	<div style="border: 1px solid black; padding: 2px; display: inline-block;"> <table style="border-collapse: collapse;"> <tr> <td style="border: 1px solid black; padding: 2px;">31</td> <td style="border: 1px solid black; padding: 2px;">General register contents</td> <td style="border: 1px solid black; padding: 2px;">0</td> </tr> </table> </div> <div style="border: 1px solid black; padding: 2px; display: inline-block; margin-top: 5px;"> <table style="border-collapse: collapse;"> <tr> <td style="border: 1px solid black; padding: 2px;">1, 2, or 4</td> </tr> </table> </div>	31	General register contents	0	1, 2, or 4	<div style="border: 1px solid black; padding: 2px; display: inline-block;"> <table style="border-collapse: collapse;"> <tr> <td style="border: 1px solid black; padding: 2px;">31</td> <td style="border: 1px solid black; padding: 2px;">Don't care</td> <td style="border: 1px solid black; padding: 2px;">24</td> <td style="border: 1px solid black; padding: 2px;">23</td> <td style="border: 1px solid black; padding: 2px;">0</td> </tr> </table> </div>	31	Don't care	24	23	0				
op	r																			
op	r																			
31	General register contents	0																		
1, 2, or 4																				
31	Don't care	24	23	0																
		<table border="1" style="border-collapse: collapse; text-align: center;"> <thead> <tr> <th>Operand Size</th> <th>Value added</th> </tr> </thead> <tbody> <tr> <td>Byte</td> <td>1</td> </tr> <tr> <td>Word</td> <td>2</td> </tr> <tr> <td>Longword</td> <td>4</td> </tr> </tbody> </table>	Operand Size	Value added	Byte	1	Word	2	Longword	4										
Operand Size	Value added																			
Byte	1																			
Word	2																			
Longword	4																			

No.	Addressing Mode and Instruction Format	Effective Address Calculation	Effective Address (EA)
5	<p>Absolute address</p> <p>@aa:8</p> <div style="border: 1px solid black; padding: 2px; display: inline-block; margin-bottom: 5px;">op abs</div> <p>@aa:16</p> <div style="border: 1px solid black; padding: 2px; display: inline-block; margin-bottom: 5px;">op abs</div> <p>@aa:24</p> <div style="border: 1px solid black; padding: 2px; display: inline-block; margin-bottom: 5px;">op abs</div> <p>@aa:32</p> <div style="border: 1px solid black; padding: 2px; display: inline-block; margin-bottom: 5px;">op abs</div>	<p>Diagram illustrating Effective Address Calculation for Absolute Addressing Modes:</p> <ul style="list-style-type: none"> @aa:8: The 8-bit absolute address (abs) is shifted left by 24 bits to form the Effective Address (EA). @aa:16: The 16-bit absolute address (abs) is shifted left by 16 bits to form the EA. @aa:24: The 24-bit absolute address (abs) is shifted left by 8 bits to form the EA. @aa:32: The 32-bit absolute address (abs) is used directly as the EA. 	<p>Diagram illustrating Effective Address (EA) for Absolute Addressing Modes:</p> <ul style="list-style-type: none"> @aa:8: EA bits 31-24 are "Don't care", bits 23-8 are "HFFFFFF", and bit 7 is 0. @aa:16: EA bits 31-16 are "Don't care", bits 15-8 are "Sign extension", and bit 7 is 0. @aa:24: EA bits 31-24 are "Don't care", and bit 23 is 0. @aa:32: EA bits 31-24 are "Don't care", and bit 23 is 0.
6	<p>Immediate #xx:8/#xx:16/#xx:32</p> <div style="border: 1px solid black; padding: 2px; display: inline-block; margin-bottom: 5px;">op IMM</div>		<p>Operand is immediate data.</p>

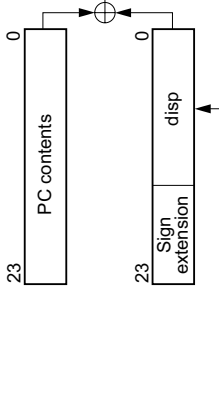
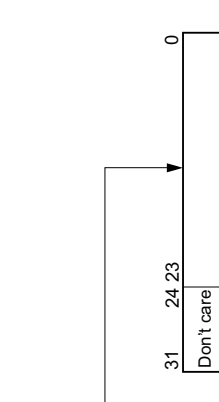
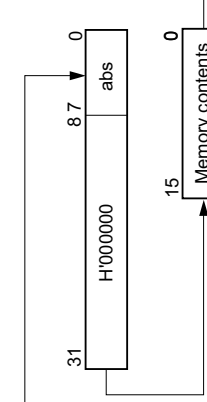
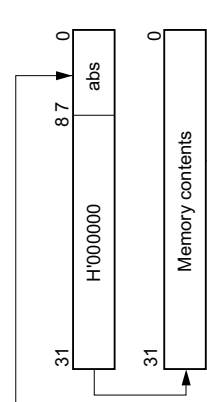
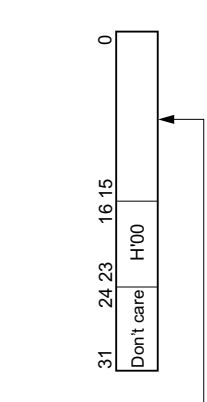
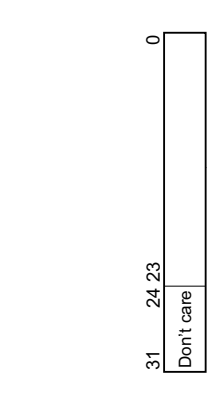
No.	Addressing Mode and Instruction Format	Effective Address Calculation	Effective Address (EA)
7	<p>Program-counter relative @(d:8, PC)@(d:16, PC)</p>		
8	<p>Memory indirect @aa:8</p> <ul style="list-style-type: none"> • Normal mode* <ul style="list-style-type: none"> • Advanced mode 	 	 

Note: * Not available in the chip.

2.8 Processing States

2.8.1 Overview

The CPU has five main processing states: the reset state, exception handling state, program execution state, bus-released state, and power-down state. Figure 2-14 shows a diagram of the processing states. Figure 2-15 indicates the state transitions.

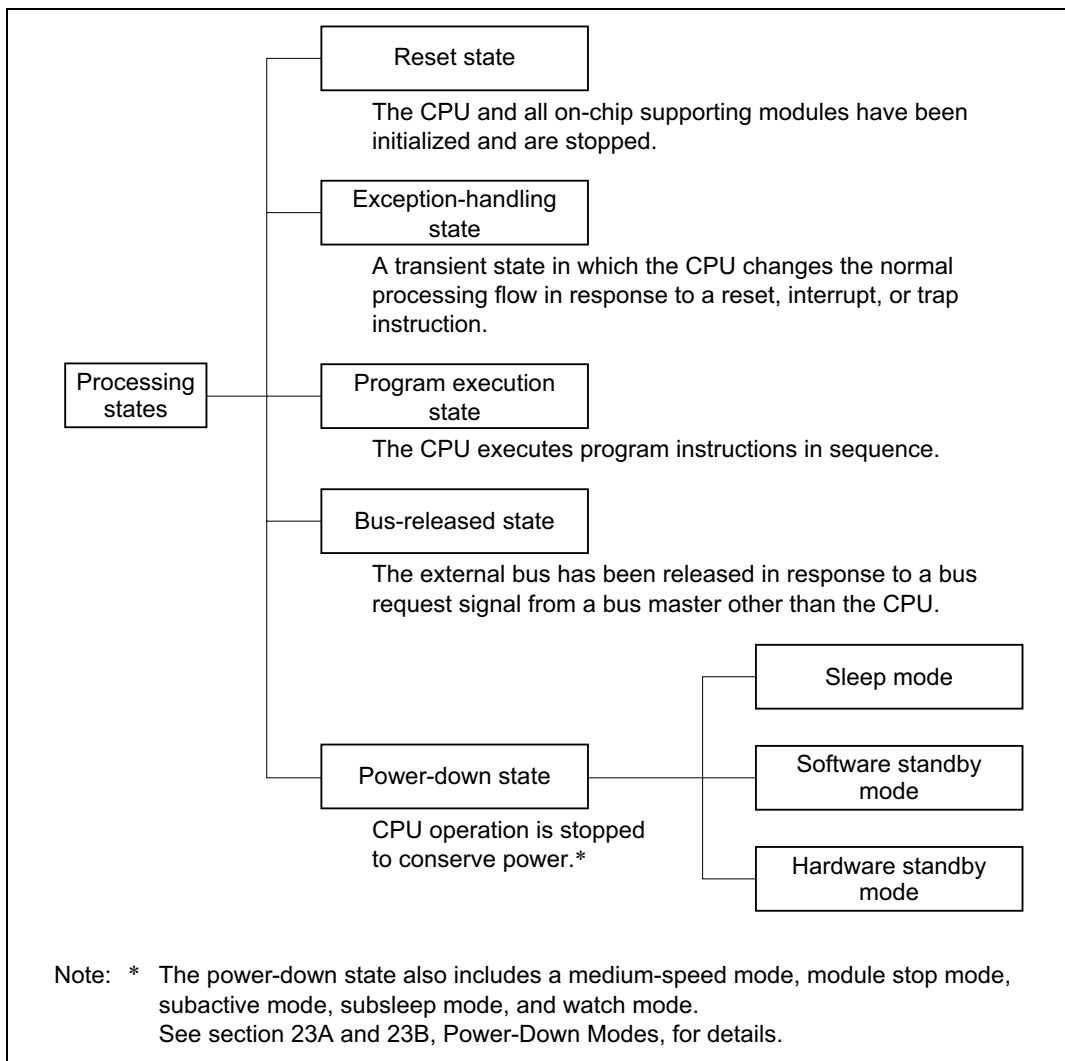

Figure 2-14 Processing States

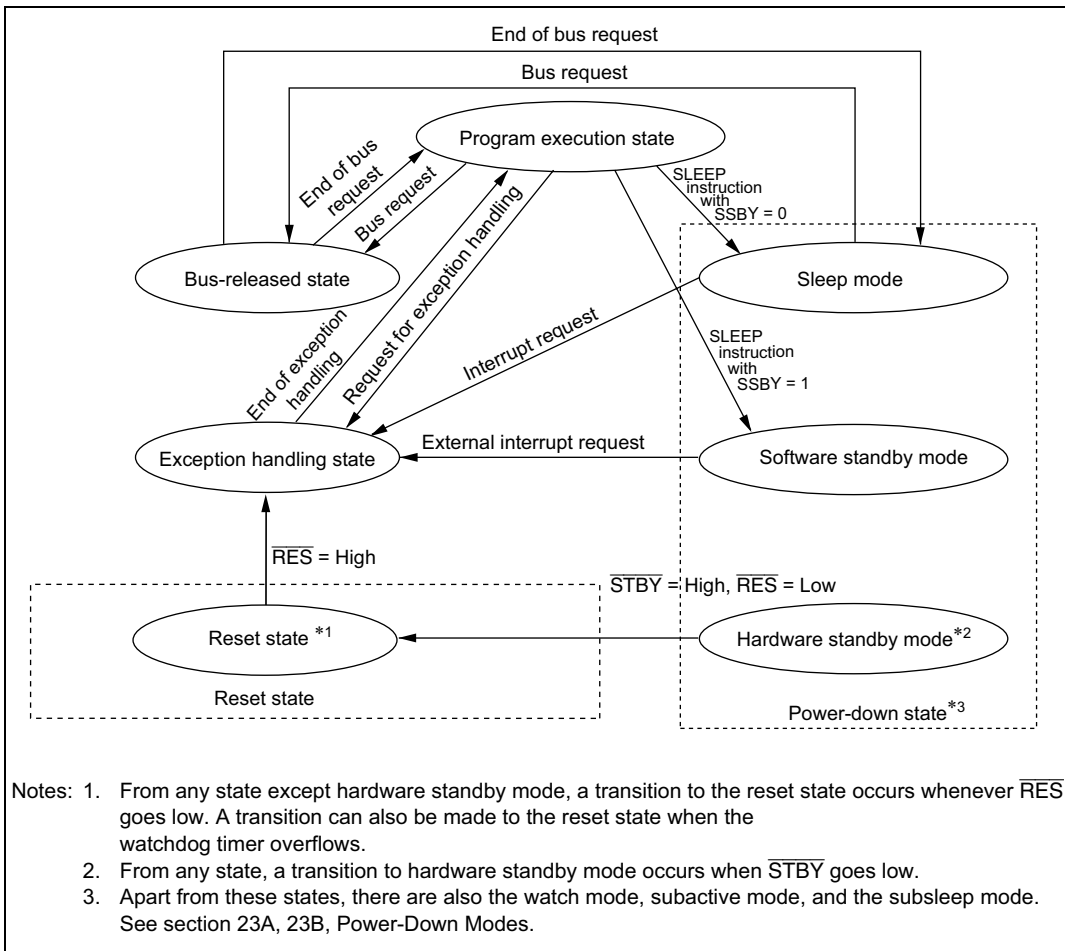

Figure 2-15 State Transitions

2.8.2 Reset State

When the \overline{RES} goes low, all current processing stops and the CPU enters the reset state. In reset state all interrupts are disabled.

Reset exception handling starts when the \overline{RES} signal changes from low to high.

The reset state can also be entered by a watchdog timer overflow. For details, refer to section 12, Watchdog Timer.

2.8.3 Exception-Handling State

The exception-handling state is a transient state that occurs when the CPU alters the normal processing flow due to a reset, interrupt, or trap instruction. The CPU fetches a start address (vector) from the exception vector table and branches to that address.

(1) Types of Exception Handling and Their Priority

Exception handling is performed for traces, resets, interrupts, and trap instructions. Table 2-7 indicates the types of exception handling and their priority. Trap instruction exception handling is always accepted, in the program execution state.

Exception handling and the stack structure depend on the interrupt control mode set in SYSCR.

Table 2-7 Exception Handling Types and Priority

Priority	Type of Exception	Detection Timing	Start of Exception Handling
 High	Reset	Synchronized with clock	Exception handling starts immediately after a low-to-high transition at the $\overline{\text{RES}}$ pin, or when the watchdog timer overflows.
	Trace	End of instruction execution or end of exception-handling sequence ^{*1}	When the trace (T) bit is set to 1, the trace starts at the end of the current instruction or current exception-handling sequence
	Interrupt	End of instruction execution or end of exception-handling sequence ^{*2}	When an interrupt is requested, exception handling starts at the end of the current instruction or current exception-handling sequence
	Trap instruction	When TRAPA instruction is executed	Exception handling starts when a trap (TRAPA) instruction is executed ^{1:*3}
Low			

- Notes: 1. Traces are enabled only in interrupt control mode 2. Trace exception-handling is not executed at the end of the RTE instruction.
 2. Interrupts are not detected at the end of the ANDC, ORC, XORC, and LDC instructions, or immediately after reset exception handling.
 3. Trap instruction exception handling is always accepted, in the program execution state.

(2) Reset Exception Handling

After the $\overline{\text{RES}}$ pin has gone low and the reset state has been entered, when $\overline{\text{RES}}$ goes high again, reset exception handling starts. The CPU enters the reset state when the $\overline{\text{RES}}$ is low. When reset exception handling starts the CPU fetches a start address (vector) from the exception vector table and starts program execution from that address. All interrupts, including NMI, are disabled during reset exception handling and after it ends.

(3) Traces

Traces are enabled only in interrupt control mode 2. Trace mode is entered when the T bit of EXR is set to 1. When trace mode is established, trace exception handling starts at the end of each instruction.

At the end of a trace exception-handling sequence, the T bit of EXR is cleared to 0 and trace mode is cleared. Interrupt masks are not affected.

The T bit saved on the stack retains its value of 1, and when the RTE instruction is executed to return from the trace exception-handling routine, trace mode is entered again. Trace exception-handling is not executed at the end of the RTE instruction.

Trace mode is not entered in interrupt control mode 0, regardless of the state of the T bit.

(4) Interrupt Exception Handling and Trap Instruction Exception Handling

When interrupt or trap-instruction exception handling begins, the CPU references the stack pointer (ER7) and pushes the program counter and other control registers onto the stack. Next, the CPU alters the settings of the interrupt mask bits in the control registers. Then the CPU fetches a start address (vector) from the exception vector table and program execution starts from that start address.

Figure 2-16 shows the stack after exception handling ends.

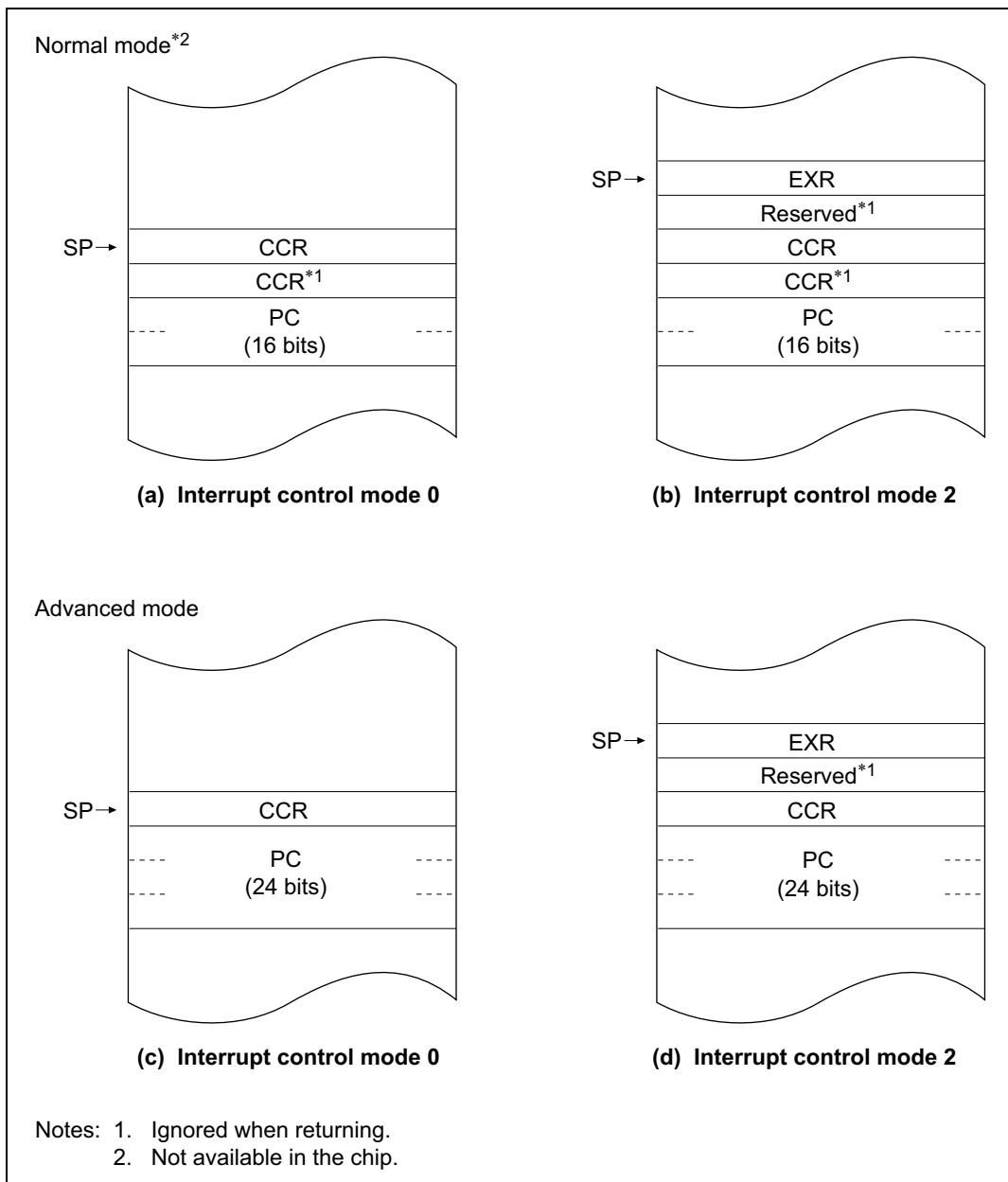

Figure 2-16 Stack Structure after Exception Handling (Examples)

2.8.4 Program Execution State

In this state the CPU executes program instructions in sequence.

2.8.5 Bus-Released State

This is a state in which the bus has been released in response to a bus request from a bus master other than the CPU. While the bus is released, the CPU halts operations.

Bus masters other than the CPU is data transfer controller (DTC).

For further details, refer to section 7, Bus Controller.

2.8.6 Power-Down State

The power-down state includes both modes in which the CPU stops operating and modes in which the CPU does not stop. There are five modes in which the CPU stops operating: sleep mode, software standby mode, hardware standby mode, subsleep mode, and watch mode. There are also three other power-down modes: medium-speed mode, module stop mode, and subactive mode. In medium-speed mode the CPU and other bus masters operate on a medium-speed clock. Module stop mode permits halting of the operation of individual modules, other than the CPU. Subactive mode, subsleep mode, and watch mode are power-down states using subclock input. For details, refer to section 23A, 23B, Power-Down Modes.

(1) Sleep Mode: A transition to sleep mode is made if the SLEEP instruction is executed while the software standby bit (SSBY) in the standby control register (SBYCR) is cleared to 0. In sleep mode, CPU operations stop immediately after execution of the SLEEP instruction. The contents of CPU registers are retained.

(2) Software Standby Mode: A transition to software standby mode is made if the SLEEP instruction is executed while the SSBY bit in SBYCR is set to 1, the LSON bit in LPWRCR is set to 0, and the PSS bit in TCSR (WDT1) is set to 0. In software standby mode, the CPU and clock halt and all MCU operations stop. As long as a specified voltage is supplied, the contents of CPU registers and on-chip RAM are retained. The I/O ports also remain in their existing states.

(3) Hardware Standby Mode: A transition to hardware standby mode is made when the $\overline{\text{STBY}}$ pin goes low. In hardware standby mode, the CPU and clock halt and all MCU operations stop. The on-chip supporting modules are reset, but as long as a specified voltage is supplied, on-chip RAM contents are retained.

2.9 Basic Timing

2.9.1 Overview

The H8S/2600 CPU is driven by a system clock, denoted by the symbol ϕ . The period from one rising edge of ϕ to the next is referred to as a "state." The memory cycle or bus cycle consists of one, two, or three states. Different methods are used to access on-chip memory, on-chip supporting modules, and the external address space.

2.9.2 On-Chip Memory (ROM, RAM)

On-chip memory is accessed in one state. The data bus is 16 bits wide, permitting both byte and word transfer instruction. Figure 2-17 shows the on-chip memory access cycle. Figure 2-18 shows the pin states.

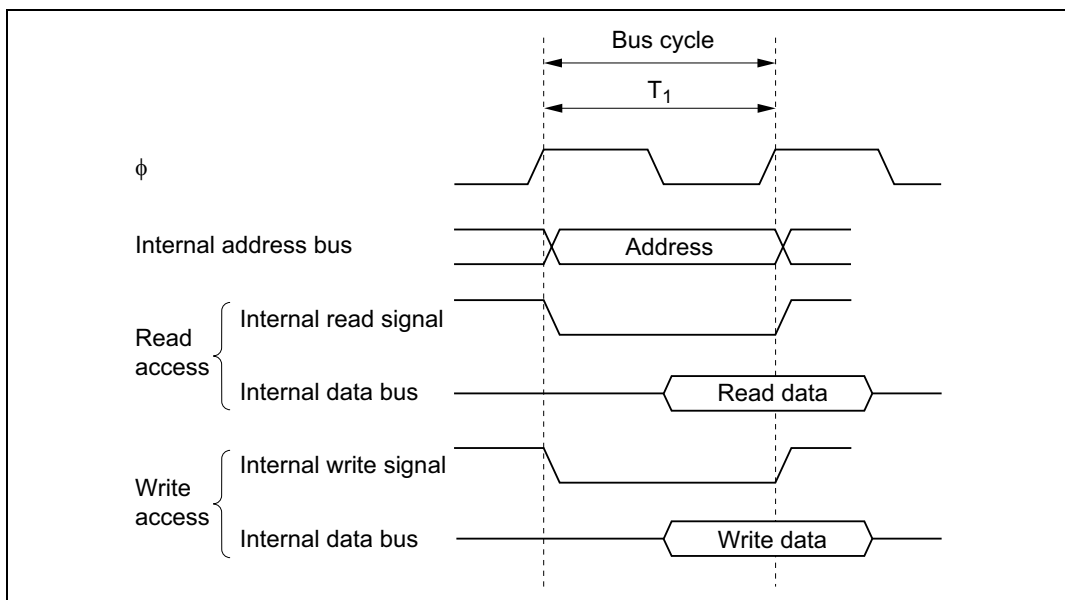

Figure 2-17 On-Chip Memory Access Cycle

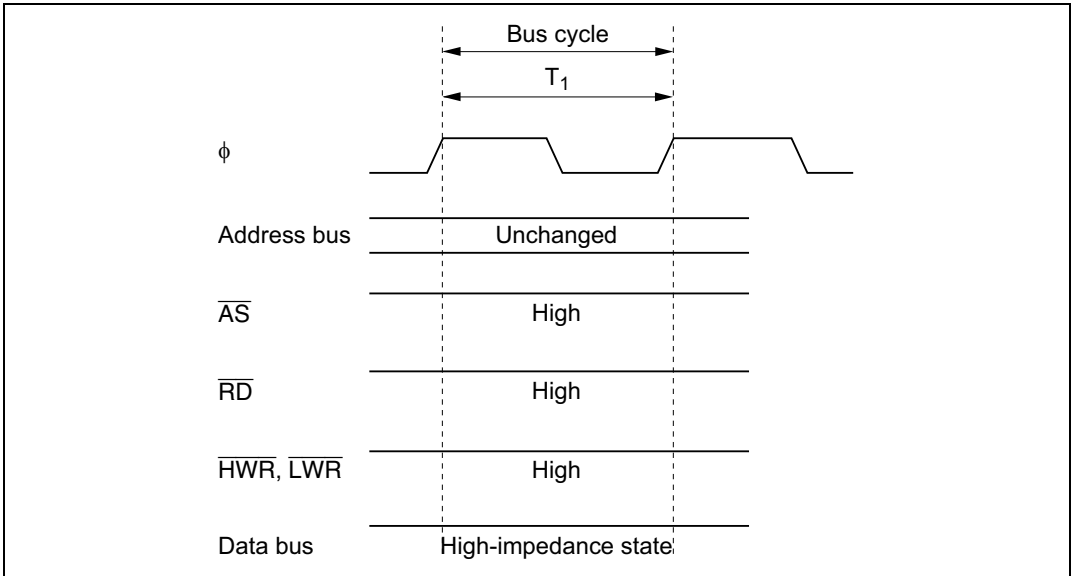

Figure 2-18 Pin States during On-Chip Memory Access

2.9.3 On-Chip Supporting Module Access Timing

The on-chip supporting modules are accessed in two states. The data bus is either 8 bits or 16 bits wide, depending on the particular internal I/O register being accessed. Figure 2-19 shows the access timing for the on-chip supporting modules. Figure 2-20 shows the pin states.

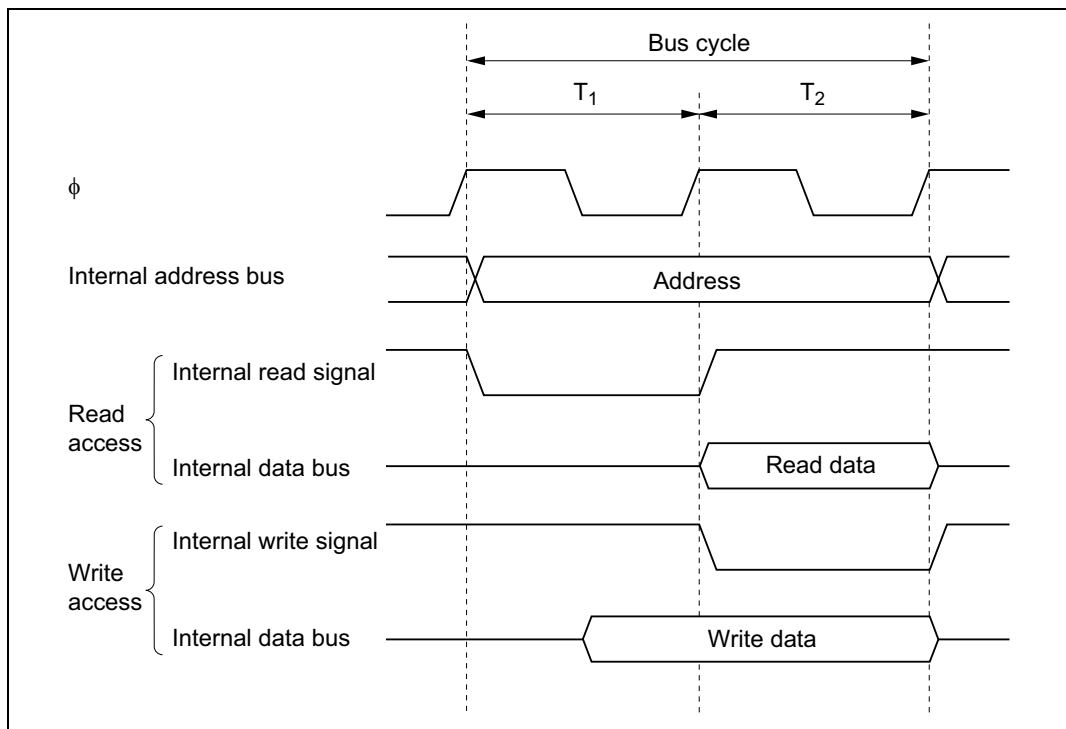

Figure 2-19 On-Chip Supporting Module Access Cycle

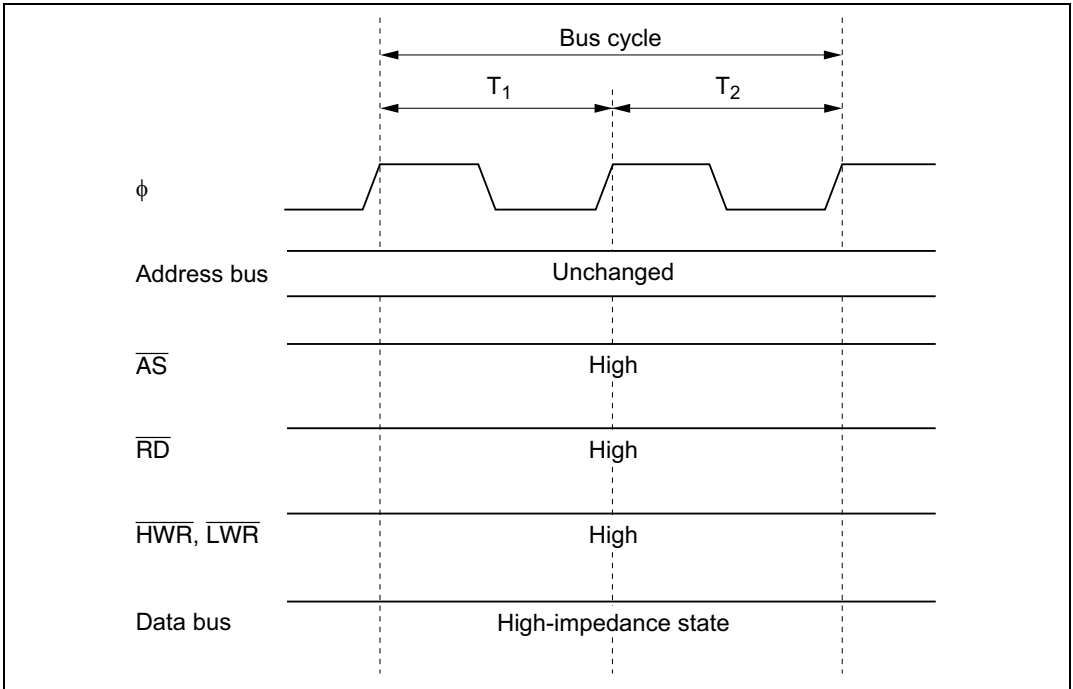

Figure 2-20 Pin States during On-Chip Supporting Module Access

2.9.4 On-Chip HCAN Module Access Timing

On-chip HCAN module access is performed in four states. The data bus width is 16 bits. Wait states can be inserted by means of a wait request from the HCAN. On-chip HCAN module access timing is shown in figures 2-21 and 2-22, and the pin states in figure 2-23.

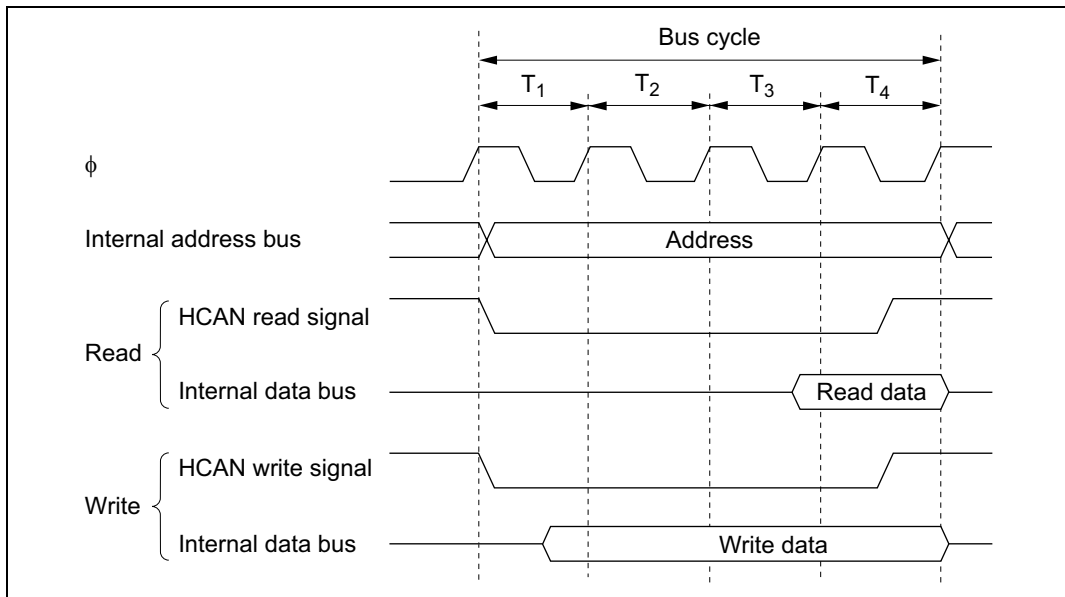

Figure 2-21 On-Chip HCAN Module Access Cycle (No Wait State)

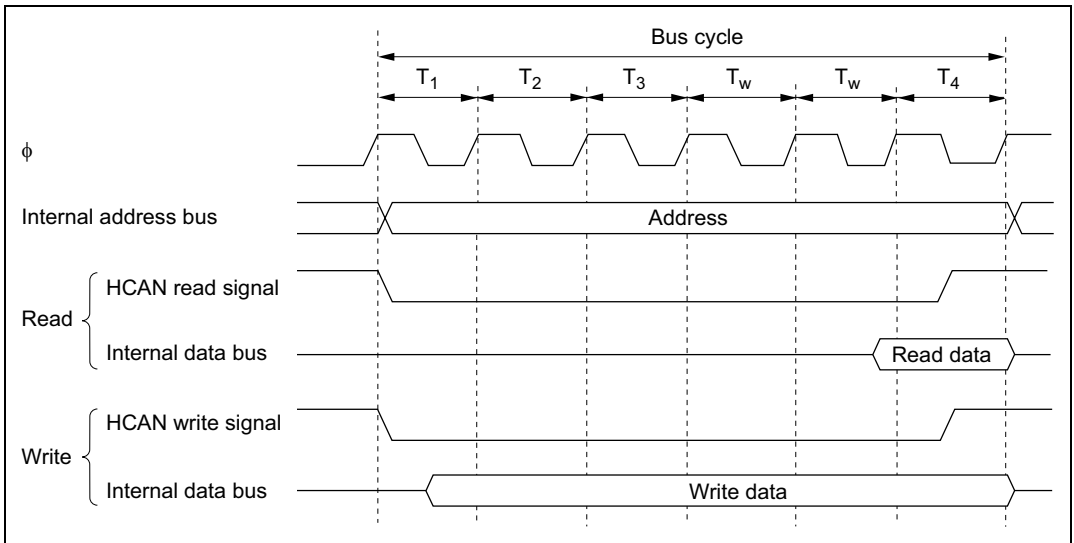

Figure 2-22 On-Chip HCAN Module Access Cycle (Wait States Inserted)

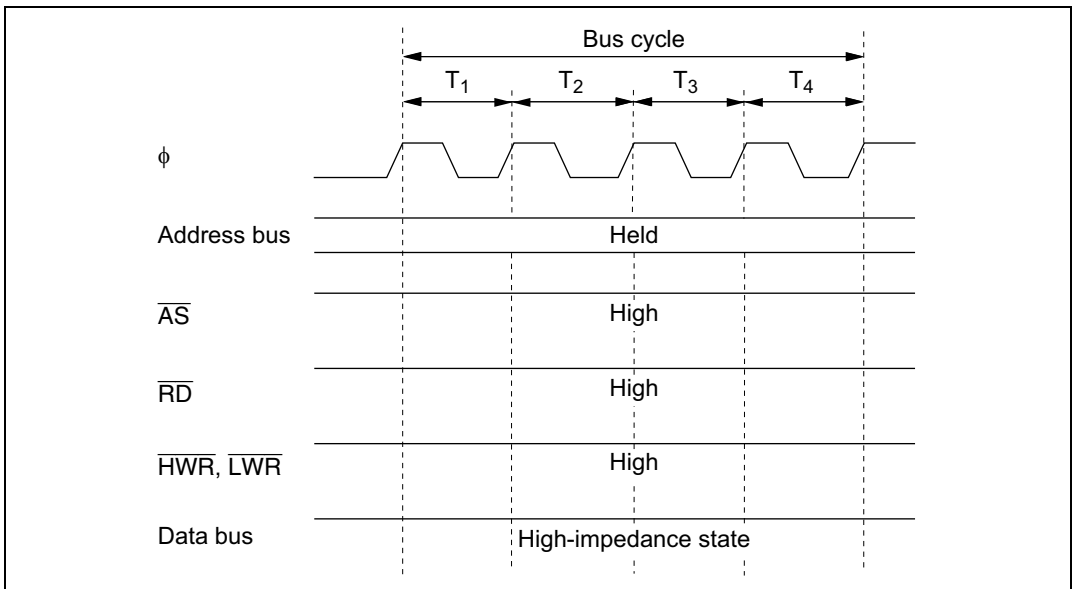

Figure 2-23 Pin States in On-Chip HCAN Module Access

2.9.5 Port H and J Register Access Timing

Accesses to port H and J registers and the on-chip motor control PWM timer module are performed in four states. The data bus width is 8 or 16 bits depending on the internal I/O register.

Access timing for port H and J registers and the on-chip motor control PWM timer module is shown in figure 2-24, and the pin states are shown in figure 2-25.

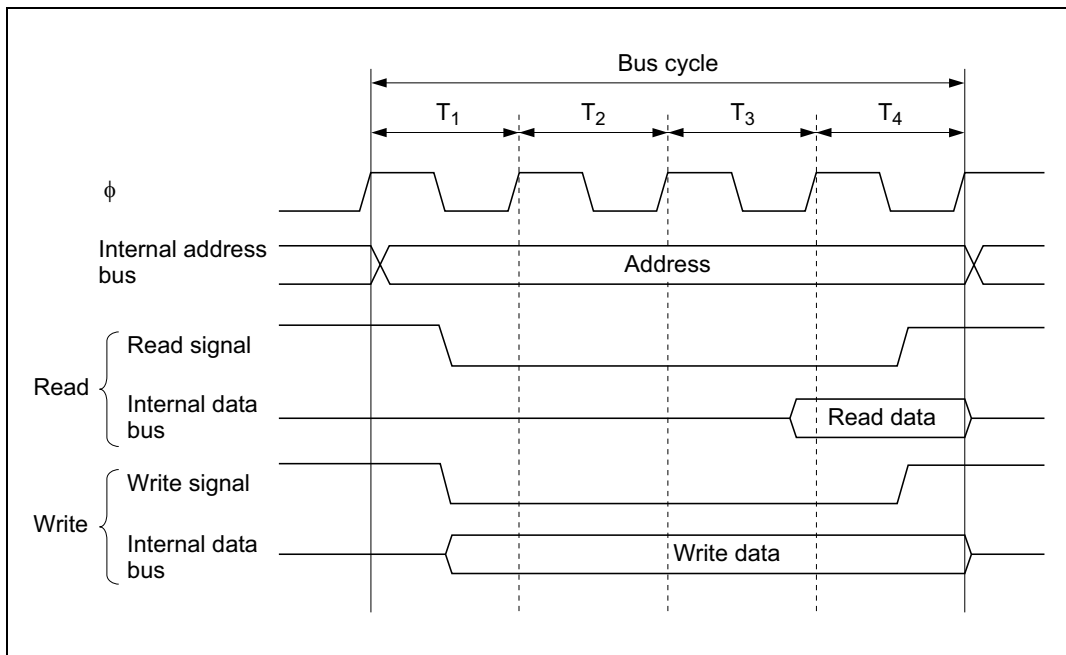

Figure 2-24 Access Cycle for Ports H and J Registers and On-Chip Motor Control PWM Timer Module

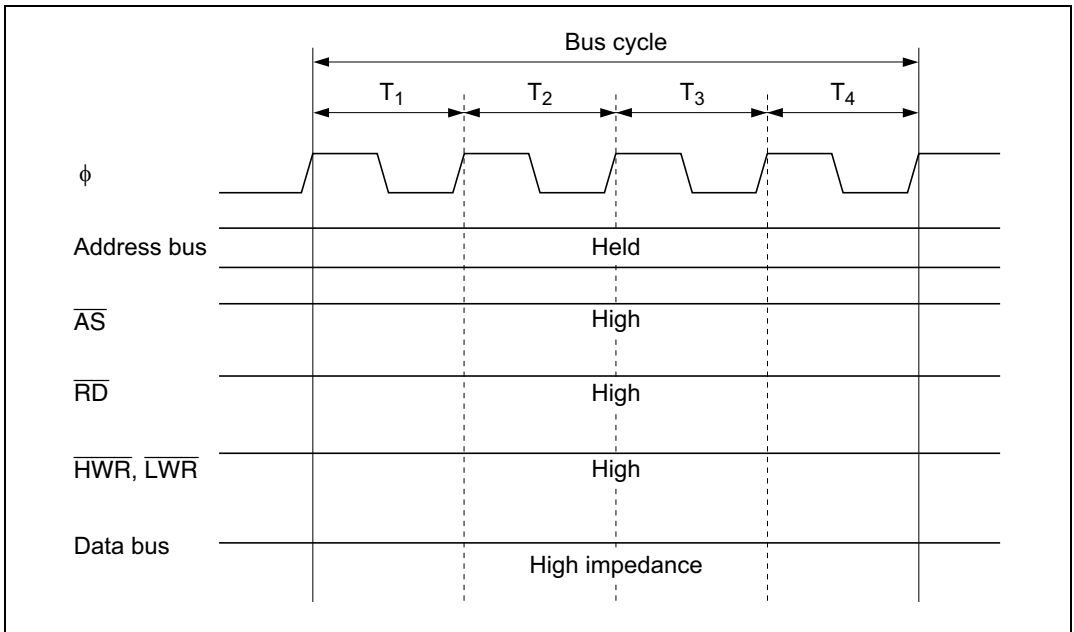

Figure 2-25 Pin States in Access to Ports H and J Registers and On-Chip Motor Control PWM Timer Module

2.9.6 External Address Space Access Timing

The external address space is accessed with an 8-bit or 16-bit data bus width in a two-state or three-state bus cycle. In three-state access, wait states can be inserted. For further details, refer to section 7, Bus Controller.

2.10 Usage Note

2.10.1 TAS Instruction

Only register ER0, ER1, ER4, or ER5 should be used when using the TAS instruction. The TAS instruction is not generated by the Renesas Technology H8S Family and H8/300 Series C/C++ compilers. If the TAS instruction is used as a user-defined intrinsic function, ensure that only register ER0, ER1, ER4, or ER5 is used.

2.10.2 STM/LDM Instructions

With STM and LDM instructions, register ER7 cannot be used as a register that can be saved (STM) or restored (LDM) since it is the stack pointer.

The number of registers that can be saved (STM) or restored (LDM) by a single instruction is two, three, or four. The registers that can be used in these cases are as follows.

Two registers: ER0–ER1, ER2–ER3, ER4–ER5

Three registers: ER0–ER2, ER4–ER6

Four registers: ER0–ER3

The Renesas Technology H8S Family and H8/300 Series C/C++ compilers do not generate STM/LDM instructions that include ER7.

2.10.3 Caution to Observe when Using Bit Manipulation Instructions

The BSET, BCLR, BNOT, BST, and BIST instructions read data in a unit of byte, then, after bit manipulation, they write data in a unit of byte. Therefore, caution must be exercised when executing any of these instructions for registers and ports that include write-only bits.

The BCLR instruction can be used to clear the flag of an internal I/O register to 0. In that case, if it is clearly known that the pertinent flag is set to 1 in an interrupt processing routine or other processing, there is no need to read the flag in advance.

Section 3 MCU Operating Modes

3.1 Overview

3.1.1 Operating Mode Selection

The chip has four operating modes (modes 4 to 7). These modes enable selection of the CPU operating mode, enabling/disabling of on-chip ROM, and the initial bus width setting, by setting the mode pins (MD2 to MD0).

Table 3-1 lists the MCU operating modes.

Table 3-1 MCU Operating Mode Selection

MCU Operating Mode	MD2	MD1	MD0	CPU Operating Mode	Description	External Data Bus		
						On-Chip ROM	Initial Width	Max. Width
0*	0	0	0	—	—	—	—	—
1*			1	—				
2*		1	0					
3*			1					
4	1	0	0	Advanced	On-chip ROM disabled, expanded mode	Disabled	16 bits	16 bits
5			1				8 bits	16 bits
6		1	0		On-chip ROM enabled, expanded mode	Enabled	8 bits	16 bits
7			1		Single-chip mode		—	—

Note: * Not available in the chip.

The CPU's architecture allows for 4 Gbytes of address space, but the chip actually accesses a maximum of 16 Mbytes.

Modes 4 to 6 are externally expanded modes that allow access to external memory and peripheral devices.

The external expansion modes allow switching between 8-bit and 16-bit bus modes. After program execution starts, an 8-bit or 16-bit address space can be set for each area, depending on

the bus controller setting. If 16-bit access is selected for any one area, 16-bit bus mode is set; if 8-bit access is selected for all areas, 8-bit bus mode is set.

Note that the functions of each pin depend on the operating mode.

The chip can be used only in modes 4 to 7. This means that the mode pins must be set to select one of these modes. Do not change the inputs at the mode pins during operation.

3.1.2 Register Configuration

The chip has a mode control register (MDCR) that indicates the inputs at the mode pins (MD2 to MD0), and a system control register (SYSCR) that controls the operation of the chip. Table 3-2 summarizes these registers.

Table 3-2 MCU Registers

Name	Abbreviation	R/W	Initial Value	Address*
Mode control register	MDCR	R	Undetermined	H'FDE7
System control register	SYSCR	R/W	H'01	H'FDE5
Pin function control register	PFCR	R/W	H'0D/H'00	H'FDEB

Note: * Lower 16 bits of the address.

3.2 Register Descriptions

3.2.1 Mode Control Register (MDCR)

Bit	:	7	6	5	4	3	2	1	0
		—	—	—	—	—	MDS2	MDS1	MDS0
Initial value	:	1	0	0	0	0	—*	—*	—*
R/W	:	R/W	—	—	—	—	R	R	R

Note: * Determined by pins MD2 to MD0.

MDCR is an 8-bit register that indicates the current operating mode of the chip.

Bit 7—Reserved: Only 1 should be written to these bits.

Bits 6 to 3—Reserved: These bits are always read as 0 and cannot be modified.

Bits 2 to 0—Mode Select 2 to 0 (MDS2 to MDS0): These bits indicate the input levels at pins MD2 to MD0 (the current operating mode). Bits MDS2 to MDS0 correspond to MD2 to MD0. MDS2 to MDS0 are read-only bits, and they cannot be written to. The mode pin (MD2 to MD0) input levels are latched into these bits when MDCR is read. These latches are cancelled by a reset.

3.2.2 System Control Register (SYSCR)

Bit	:	7	6	5	4	3	2	1	0
		MACS	—	INTM1	INTM0	NMIEG	—	—	RAME
Initial value	:	0	0	0	0	0	0	0	1
R/W	:	R/W	—	R/W	R/W	R/W	—	—	R/W

SYSCR is an 8-bit readable-writable register that selects saturating or non-saturating calculation for the MAC instruction, selects the interrupt control mode, selects the detected edge for NMI, and enables or disables on-chip RAM.

SYSCR is initialized to H'01 by a reset and in hardware standby mode. SYSCR is not initialized in software standby mode.

Bit 7—MAC Saturation (MACS): Selects either saturating or non-saturating calculation for the MAC instruction.

Bit 7

MACS	Description
0	Non-saturating calculation for MAC instruction (Initial value)
1	Saturating calculation for MAC instruction

Bit 6—Reserved: This bit is always read as 0 and cannot be modified.

Bits 5 and 4—Interrupt Control Mode 1 and 0 (INTM1, INTM0): These bits select the control mode of the interrupt controller. For details of the interrupt control modes, see section 5.4.1, Interrupt Control Modes and Interrupt Operation.

Bit 5	Bit 4	Interrupt Control Mode	Description
INTM1	INTM0		
0	0	0	Control of interrupts by I bit (Initial value)
	1	—	Setting prohibited
1	0	2	Control of interrupts by I2 to I0 bits and IPR
	1	—	Setting prohibited

Bit 3—NMI Edge Select (NMIEG): Selects the valid edge of the NMI interrupt input.

Bit 3	Description
NMIEG	
0	An interrupt is requested at the falling edge of NMI input (Initial value)
1	An interrupt is requested at the rising edge of NMI input

Bit 2—Reserved: Only 0 should be written to this bit.

Bit 1—Reserved: This bit is always read as 0 and cannot be modified.

Bit 0—RAM Enable (RAME): Enables or disables the on-chip RAM. The RAME bit is initialized when the reset status is released. It is not initialized in software standby mode.

Bit 0	Description
RAME	
0	On-chip RAM is disabled
1	On-chip RAM is enabled (Initial value)

Note: When the DTC is used, the RAME bit must not be cleared to 0.

3.2.3 Pin Function Control Register (PFCR)

Bit	:	7	6	5	4	3	2	1	0
		—	—	—	—	AE3	AE2	AE1	AE0
Initial value	:	0	0	0	0	1/0	1/0	0	1/0
R/W	:	R/W	R/W	R/W	R/W	R/W	R/W	R/W	R/W

PFCR is an 8-bit readable-writeable register that performs address output control in on-chip ROM-enabled expansion mode.

PFCR is initialized to H'0D/H'00 by a reset and in the hardware standby mode.

Bits 7 to 4—Reserved: Only 0 should be written to these bits.

Bits 3 to 0—Address Output Enable 3 to 0 (AE3 to AE0): These bits select enabling or disabling of address outputs A8 to A23 in on-chip ROM-disabled expansion mode and on-chip ROM-enabled expansion mode. When a pin is enabled for address output, the address is output regardless of the corresponding DDR setting. When a pin is disabled for address output, it becomes an output port when the corresponding DDR bit is set to 1.

Bit 3	Bit 2	Bit 1	Bit 0	Description
AE3	AE2	AE1	AE0	
0	0	0	0	A8 to A23 address output disabled (Initial value [*])
			1	A8 address output enabled; A9 to A23 address output disabled
		1	0	A8, A9 address output enabled; A10 to A23 address output disabled
			1	A8 to A10 address output enabled; A11 to A23 address output disabled
	1	0	0	A8 to A11 address output enabled; A12 to A23 address output disabled
			1	A8 to A12 address output enabled; A13 to A23 address output disabled
		1	0	A8 to A13 address output enabled; A14 to A23 address output disabled
			1	A8 to A14 address output enabled; A15 to A23 address output disabled
1	0	0	0	A8 to A15 address output enabled; A16 to A23 address output disabled
			1	A8 to A16 address output enabled; A17 to A23 address output disabled
		1	0	A8 to A17 address output enabled; A18 to A23 address output disabled
			1	A8 to A18 address output enabled; A19 to A23 address output disabled
	1	0	0	A8 to A19 address output enabled; A20 to A23 address output disabled
			1	A8 to A20 address output enabled; A21 to A23 address output disabled (Initial value [*])
		1	0	A8 to A21 address output enabled; A22, A23 address output disabled
			1	A8 to A23 address output enabled

Note: * In on-chip ROM-enabled expansion mode, bits AE3 to AE0 are initialized to B'0000.

In on-chip ROM-disabled expansion mode, bits AE3 to AE0 are initialized to B'1101.

Address pins A0 to A7 are made address outputs by setting the corresponding DDR bits to 1.

3.3 Operating Mode Descriptions

3.3.1 Mode 4

The CPU can access a 16-Mbyte address space in advanced mode. The on-chip ROM is disabled.

Ports 1, A, B, and C function as an address bus, ports D and E function as a data bus, and part of port F carries bus control signals.

The initial bus mode after a reset is 16 bits, with 16-bit access to all areas. However, note that if 8-bit access is designated by the bus controller for all areas, the bus mode switches to 8 bits.

3.3.2 Mode 5

The CPU can access a 16-Mbyte address space in advanced mode. The on-chip ROM is disabled.

Ports 1, A, B, and C function as an address bus, port D function as a data bus, and part of port F carries bus control signals.

The initial bus mode after a reset is 8 bits, with 8-bit access to all areas. However, note that if 16-bit access is designated by the bus controller for any area, the bus mode switches to 16 bits and port E becomes a data bus.

3.3.3 Mode 6

The CPU can access a 16-Mbyte address space in advanced mode. The on-chip ROM is enabled.

Ports 1, A, B, and C function as input port pins immediately after a reset. Address output can be performed by setting the corresponding DDR (data direction register) bits to 1.

Port D functions as a data bus, and part of port F carries bus control signals.

The initial bus mode after a reset is 8 bits, with 8-bit access to all areas. However, note that if 16-bit access is designated by the bus controller for any area, the bus mode switches to 16 bits and port E becomes a data bus.

3.3.4 Mode 7

The CPU can access a 16-Mbyte address space in advanced mode. The on-chip ROM is enabled, but external addresses cannot be accessed.

All I/O ports are available for use as input-output ports.

3.4 Pin Functions in Each Operating Mode

The pin functions of ports 1 and A to F vary depending on the operating mode. Table 3-3 shows their functions in each operating mode.

Table 3-3 Pin Functions in Each Mode

Port		Mode 4	Mode 5	Mode 6	Mode 7
Port A		P/A*	P/A*	P*/A	P
Port B		P/A*	P/A*	P*/A	P
Port C		A	A	P*/A	P
Port D		D	D	D	P
Port E		P/D*	P*/D	P*/D	P
Port F	PF7	P/C*	P/C*	P/C*	P*/C
	PF6 to PF4	C	C	C	P
	PF3	P/C*	P*/C	P*/C	
	PF0	P*/C	P*/C	P*/C	
Port 1	P11 to P13	P*/A	P*/A	P*/A	P
	P10	P/A*	P/A*	P*/A	

Legend:

P: I/O port

A: Address bus output

D: Data bus I/O

C: Control signals, clock I/O

*: After reset

3.5 Address Map in Each Operating Mode

An address map of the H8S/2636 is shown in figure 3-1.

An address map of the H8S/2638 and H8S/2639 is shown in figure 3-2.

An address map of the H8S/2630 is shown in figure 3-3.

An address map of the H8S/2635 is shown in figure 3-4.

An address map of the H8S/2634 is shown in figure 3-5.

The address space is 16 Mbytes in modes 4 to 7 (advanced modes).

The address space is divided into eight areas for modes 4 to 7. For details, see section 7, Bus Controller.

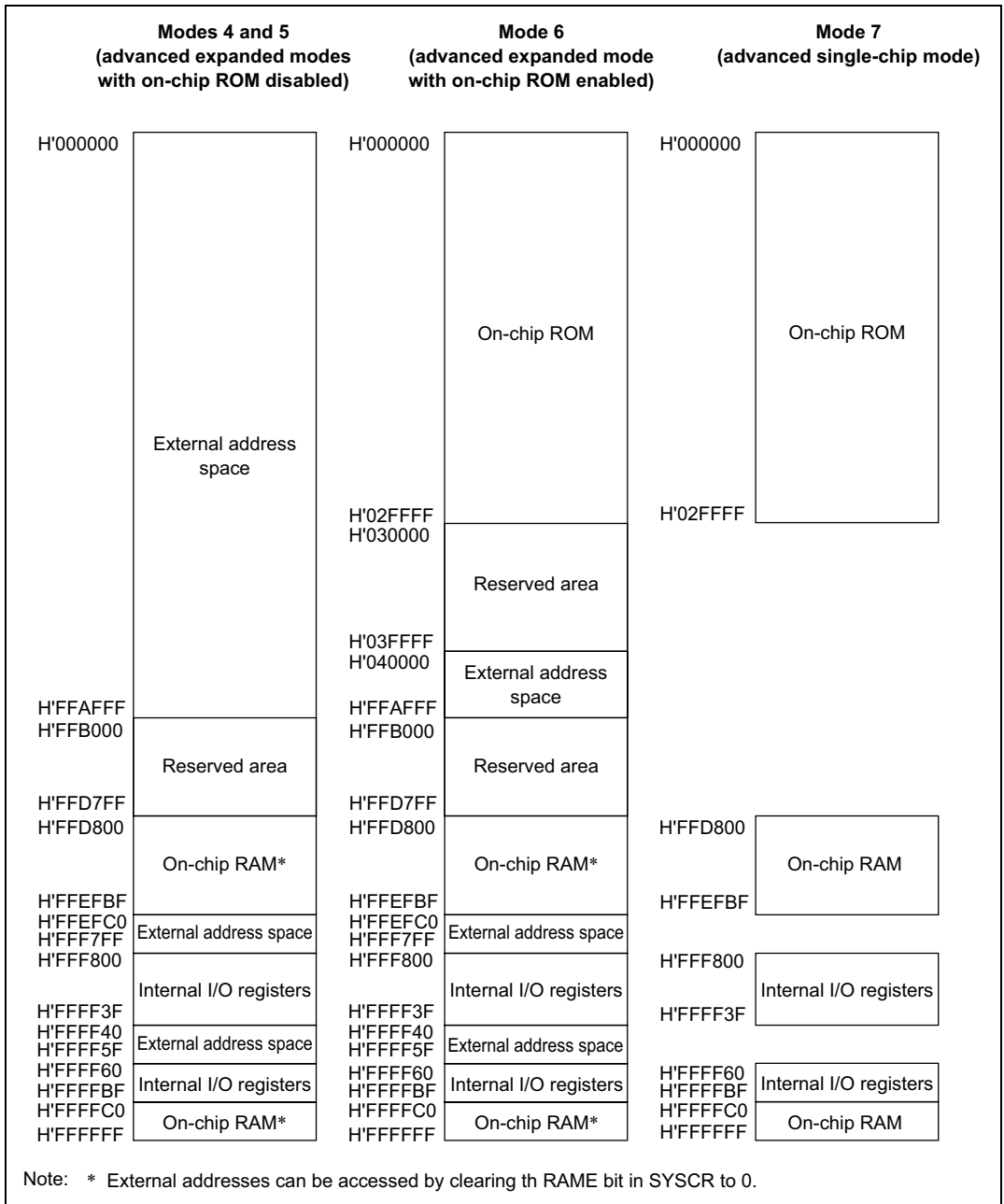

Figure 3-4 Memory Map in Each Operating Mode in the H8S/2635

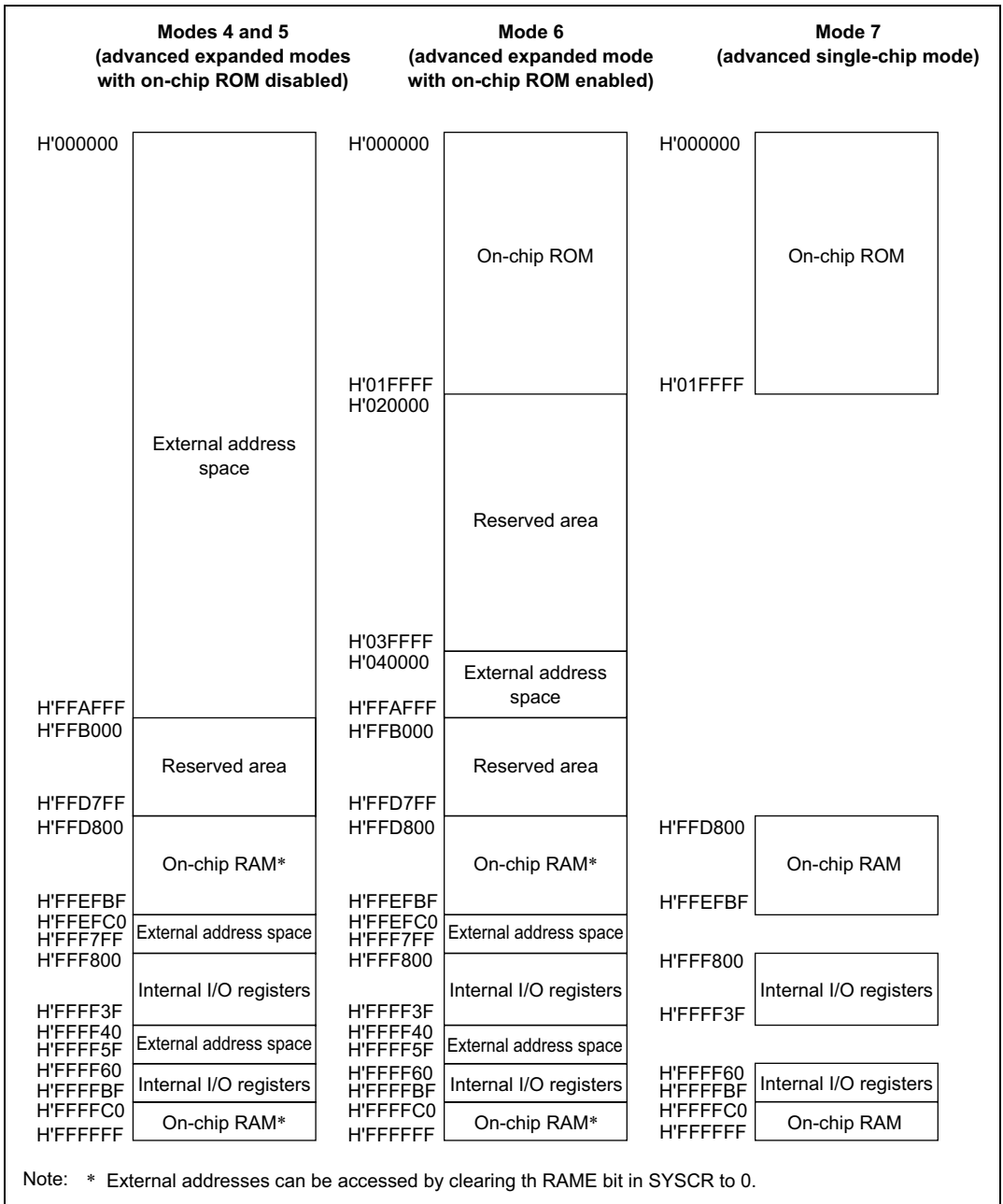

Figure 3-5 Memory Map in Each Operating Mode in the H8S/2634

Section 4 Exception Handling

4.1 Overview

4.1.1 Exception Handling Types and Priority

As table 4-1 indicates, exception handling may be caused by a reset, direct transition*, trap instruction, or interrupt. Exception handling is prioritized as shown in table 4-1. If two or more exceptions occur simultaneously, they are accepted and processed in order of priority. Trap instruction exceptions are accepted at all times, in the program execution state.

Exception handling sources, the stack structure, and the operation of the CPU vary depending on the interrupt control mode set by the INTM0 and INTM1 bits of SYSCR.

Note: * Subclock functions (subactive mode, subsleep mode, and watch mode) are available in the U-mask and W-mask versions, and H8S/2635 Group only. These functions cannot be used with the other versions.

Table 4-1 Exception Types and Priority

Priority	Exception Type	Start of Exception Handling
High ↑	Reset	Starts immediately after a low-to-high transition at the $\overline{\text{RES}}$ pin, or when the watchdog overflows. The CPU enters the reset state when the $\overline{\text{RES}}$ pin is low.
	Trace* ¹	Starts when execution of the current instruction or exception handling ends, if the trace (T) bit is set to 1
	Direct transition* ⁴	Starts when a direct transition occurs due to execution of a SLEEP instruction.
	Interrupt	Starts when execution of the current instruction or exception handling ends, if an interrupt request has been issued* ²
Low	Trap instruction (TRAPA)* ³	Started by execution of a trap instruction (TRAPA)

Notes: 1. Traces are enabled only in interrupt control mode 2. Trace exception handling is not executed after execution of an RTE instruction.
 2. Interrupt detection is not performed on completion of ANDC, ORC, XORC, or LDC instruction execution, or on completion of reset exception handling.
 3. Trap instruction exception handling requests are accepted at all times in program execution state.
 4. Subclock functions (subactive mode, subsleep mode, and watch mode) are available in the U-mask and W-mask versions, and H8S/2635 Group only. These functions cannot be used with the other versions.
 Supported by the H8S/2635.

4.1.2 Exception Handling Operation

Exceptions originate from various sources. Trap instructions and interrupts are handled as follows:

1. The program counter (PC), condition code register (CCR), and extended register (EXR) are pushed onto the stack.
2. The interrupt mask bits are updated. The T bit is cleared to 0.
3. A vector address corresponding to the exception source is generated, and program execution starts from that address.

For a reset exception, steps 2 and 3 above are carried out.

4.1.3 Exception Vector Table

The exception sources are classified as shown in figure 4-1. Different vector addresses are assigned to different exception sources.

Table 4-2 lists the exception sources and their vector addresses.

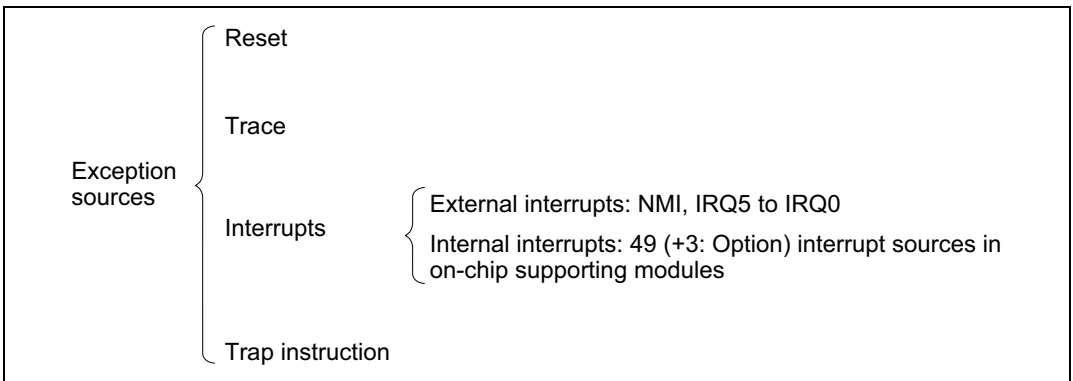

Figure 4-1 Exception Sources

Table 4-2 Exception Vector Table

Exception Source		Vector Number	Vector Address*1
			Advanced Mode
Reset		0	H'0000 to H'0003
Reserved for system use		1	H'0004 to H'0007
		2	H'0008 to H'000B
		3	H'000C to H'000F
		4	H'0010 to H'0013
		5	H'0014 to H'0017
Trace		5	H'0014 to H'0017
Direct Transition*3		6	H'0018 to H'001B
External interrupt	NMI	7	H'001C to H'001F
Trap instruction (4 sources)		8	H'0020 to H'0023
		9	H'0024 to H'0027
		10	H'0028 to H'002B
		11	H'002C to H'002F
		12	H'0030 to H'0033
Reserved for system use		13	H'0034 to H'0037
		14	H'0038 to H'003B
		15	H'003C to H'003F
External interrupt	IRQ0	16	H'0040 to H'0043
	IRQ1	17	H'0044 to H'0047
	IRQ2	18	H'0048 to H'004B
	IRQ3	19	H'004C to H'004F
	IRQ4	20	H'0050 to H'0053
	IRQ5	21	H'0054 to H'0057
Reserved for system use		22	H'0058 to H'005B
		23	H'005C to H'005F
Internal interrupt*2		24	H'0060 to H'0063
		127	H'01FC to H'01FF

Notes: 1. Lower 16 bits of the address.

2. For details of internal interrupt vectors, see section 5.3.3, Interrupt Exception Handling Vector Table.

3. See section 23B.11, Direct Transition for details on direct transition.

Subclock functions are available in the U-mask and W-mask versions, and H8S/2635 Group only.

4.2 Reset

4.2.1 Overview

A reset has the highest exception priority.

When the $\overline{\text{RES}}$ pin goes low, all current operations are stopped, and this LSI enters reset state. A reset initializes the internal state of the CPU and the registers of on-chip supporting modules. Immediately after a reset, interrupt control mode 0 is set.

When the $\overline{\text{RES}}$ pin goes from low to high, reset exception handling starts.

The H8S/2636 can also be reset by overflow of the watchdog timer. For details see section 12, Watchdog Timer.

4.2.2 Reset Sequence

This LSI enters reset state when the $\overline{\text{RES}}$ pin goes low.

To ensure that this LSI is reset, hold the $\overline{\text{RES}}$ pin low for at least 20 ms at power-up. To reset during operation, hold the $\overline{\text{RES}}$ pin low for at least 20 states.

When the $\overline{\text{RES}}$ pin goes high after being held low for the necessary time, this LSI starts reset exception handling as follows.

1. The internal state of the CPU and the registers of the on-chip supporting modules are initialized, the T bit is cleared to 0 in EXR, and the I bit is set to 1 in EXR and CCR.
2. The reset exception handling vector address is read and transferred to the PC, and program execution starts from the address indicated by the PC.

Figures 4-2 and 4-3 show examples of the reset sequence.

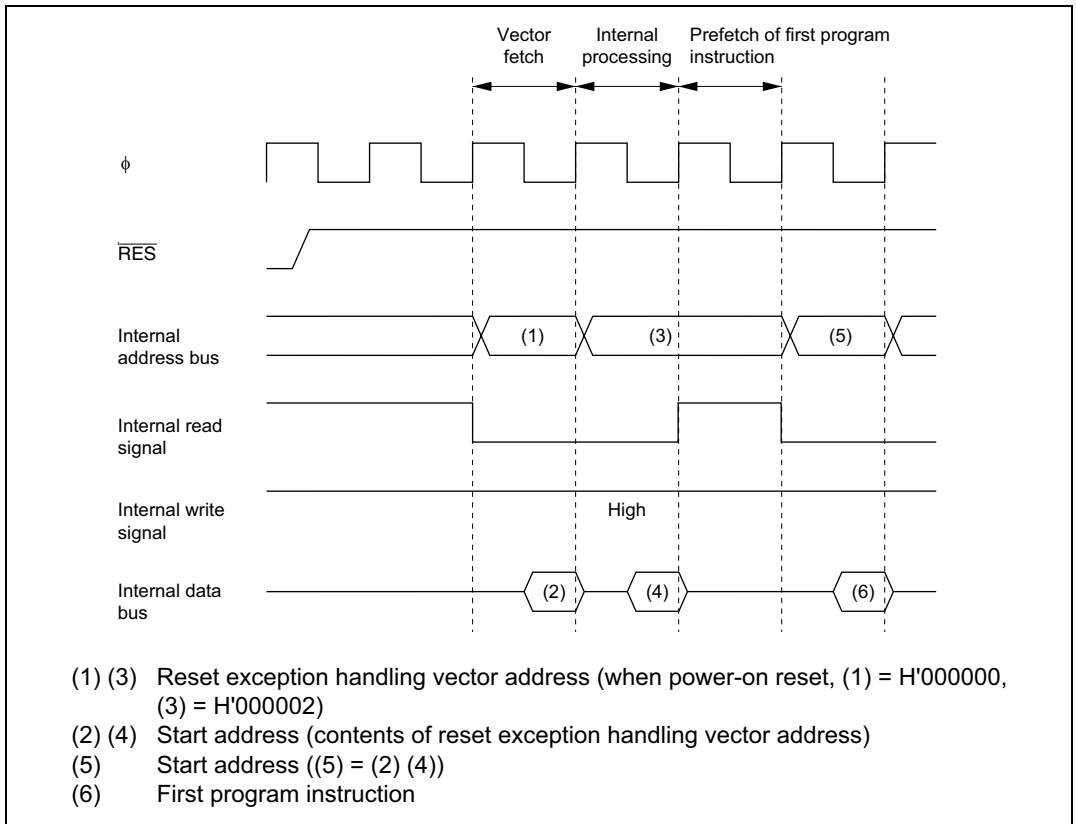

Figure 4-2 Reset Sequence (Modes 6 and 7)

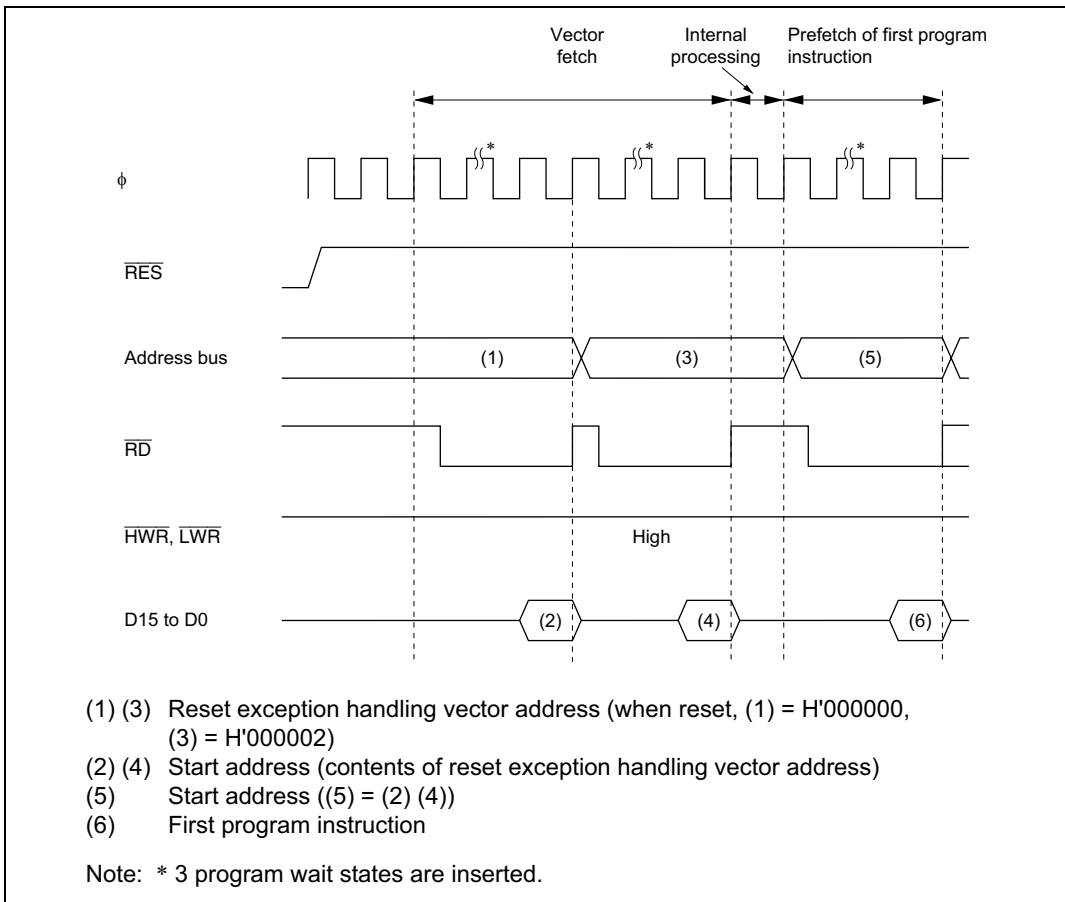

Figure 4-3 Reset Sequence (Mode 4)

4.2.3 Interrupts after Reset

If an interrupt is accepted after a reset but before the stack pointer (SP) is initialized, the PC and CCR will not be saved correctly, leading to a program crash. To prevent this, all interrupt requests, including NMI, are disabled immediately after a reset. Since the first instruction of a program is always executed immediately after the reset state ends, make sure that this instruction initializes the stack pointer (example: `MOV.L #xx: 32, SP`).

4.2.4 State of On-Chip Supporting Modules after Reset Release

After reset release, MSTPCRA to MSTPCRD are initialized to H'3F, H'FF, H'FF, and B'11*****¹, respectively, and all modules except the DTC, enter module stop mode. Consequently, on-chip supporting module registers cannot be read or written to. Register reading and writing is enabled when module stop mode is exited.

Note: 1. The value of bits 5 to 0 is undefined.

4.3 Traces

Traces are enabled in interrupt control mode 2. Trace mode is not activated in interrupt control mode 0, irrespective of the state of the T bit. For details of interrupt control modes, see section 5, Interrupt Controller.

If the T bit in EXR is set to 1, trace mode is activated. In trace mode, a trace exception occurs on completion of each instruction.

Trace mode is canceled by clearing the T bit in EXR to 0. It is not affected by interrupt masking.

Table 4-3 shows the state of CCR and EXR after execution of trace exception handling.

Interrupts are accepted even within the trace exception handling routine.

The T bit saved on the stack retains its value of 1, and when control is returned from the trace exception handling routine by the RTE instruction, trace mode resumes.

Trace exception handling is not carried out after execution of the RTE instruction.

Table 4-3 Status of CCR and EXR after Trace Exception Handling

Interrupt Control Mode	CCR		EXR	
	I	UI	I2 to I0	T
0	Trace exception handling cannot be used.			
2	1	—	—	0

Legend:

1: Set to 1

0: Cleared to 0

—: Retains value prior to execution.

4.4 Interrupts

Interrupt exception handling can be requested by seven external sources (NMI, IRQ5 to IRQ0) and 49 internal sources in the on-chip supporting modules. Figure 4-4 classifies the interrupt sources and the number of interrupts of each type.

The on-chip supporting modules that can request interrupts include the watchdog timer (WDT), 16-bit timer-pulse unit (TPU), serial communication interface (SCI), data transfer controller (DTC), PC break controller (PBC), A/D converter, controller area network (HCAN), motor control PWM timer, and I²C bus interface (IIC). Each interrupt source has a separate vector address.

NMI is the highest-priority interrupt. Interrupts are controlled by the interrupt controller. The interrupt controller has two interrupt control modes and can assign interrupts other than NMI to eight priority/mask levels to enable multiplexed interrupt control.

For details of interrupts, see section 5, Interrupt Controller.

Notes: The DTC, PBC, and IIC are not implemented in the H8S/2635 Group.

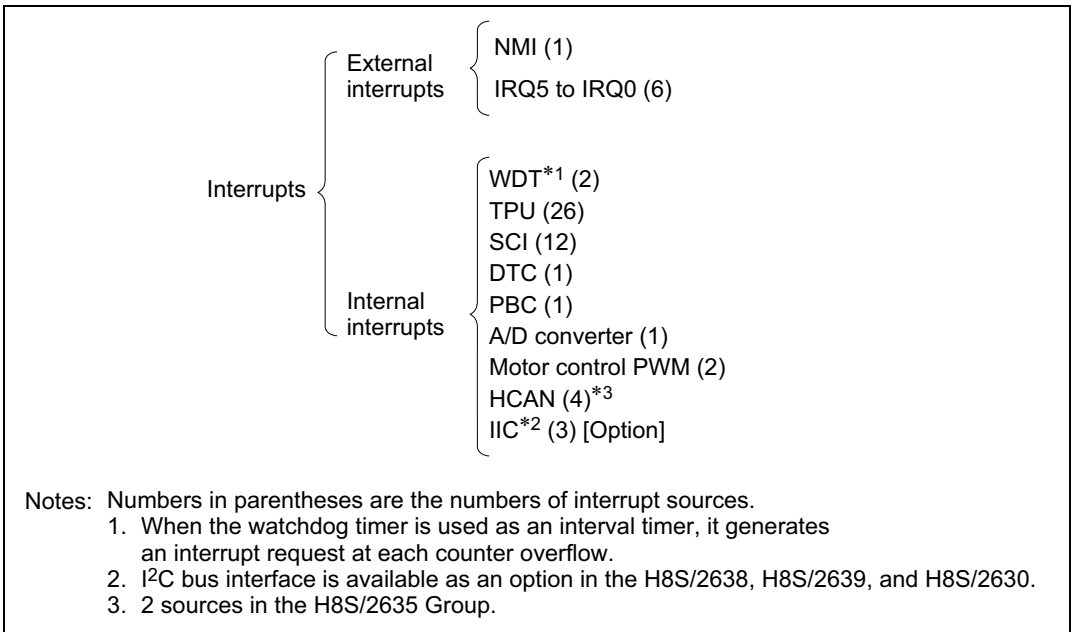

Figure 4-4 Interrupt Sources and Number of Interrupts

4.5 Trap Instruction

Trap instruction exception handling starts when a TRAPA instruction is executed. Trap instruction exception handling can be executed at all times in the program execution state.

The TRAPA instruction fetches a start address from a vector table entry corresponding to a vector number from 0 to 3, as specified in the instruction code.

Table 4-4 shows the status of CCR and EXR after execution of trap instruction exception handling.

Table 4-4 Status of CCR and EXR after Trap Instruction Exception Handling

Interrupt Control Mode	CCR		EXR	
	I	UI	I2 to I0	T
0	1	—	—	—
2	1	—	—	0

Legend:

1: Set to 1

0: Cleared to 0

—: Retains value prior to execution.

4.6 Stack Status after Exception Handling

Figure 4-5 shows the stack after completion of trap instruction exception handling and interrupt exception handling.

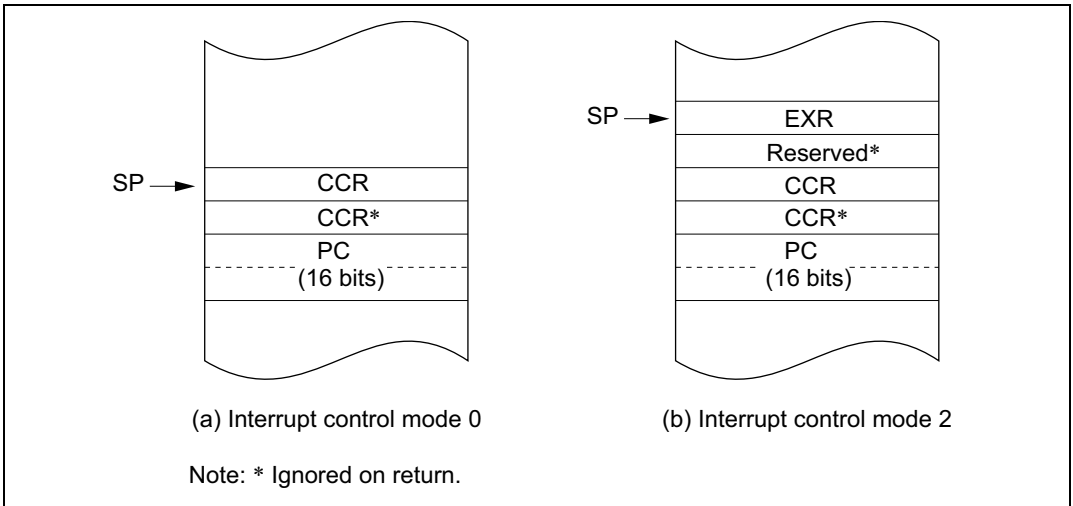

**Figure 4-5 (1) Stack Status after Exception Handling
(Normal Modes: Not Available in the Chip)**

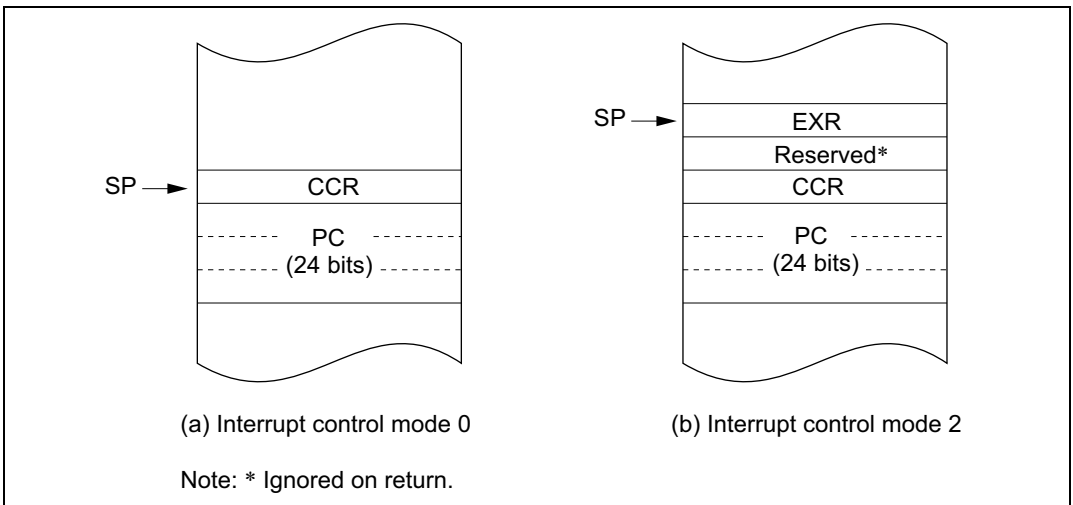

Figure 4-5 (2) Stack Status after Exception Handling (Advanced Modes)

4.7 Notes on Use of the Stack

When accessing word data or longword data, the chip assumes that the lowest address bit is 0. The stack should always be accessed by word transfer instruction or longword transfer instruction, and the value of the stack pointer (SP, ER7) should always be kept even. Use the following instructions to save registers:

```
PUSH.W   Rn      (or MOV.W Rn, @-SP)
PUSH.L   ERn     (or MOV.L ERn, @-SP)
```

Use the following instructions to restore registers:

```
POP.W    Rn      (or MOV.W @SP+, Rn)
POP.L    ERn     (or MOV.L @SP+, ERn)
```

Setting SP to an odd value may lead to a malfunction. Figure 4-6 shows an example of what happens when the SP value is odd.

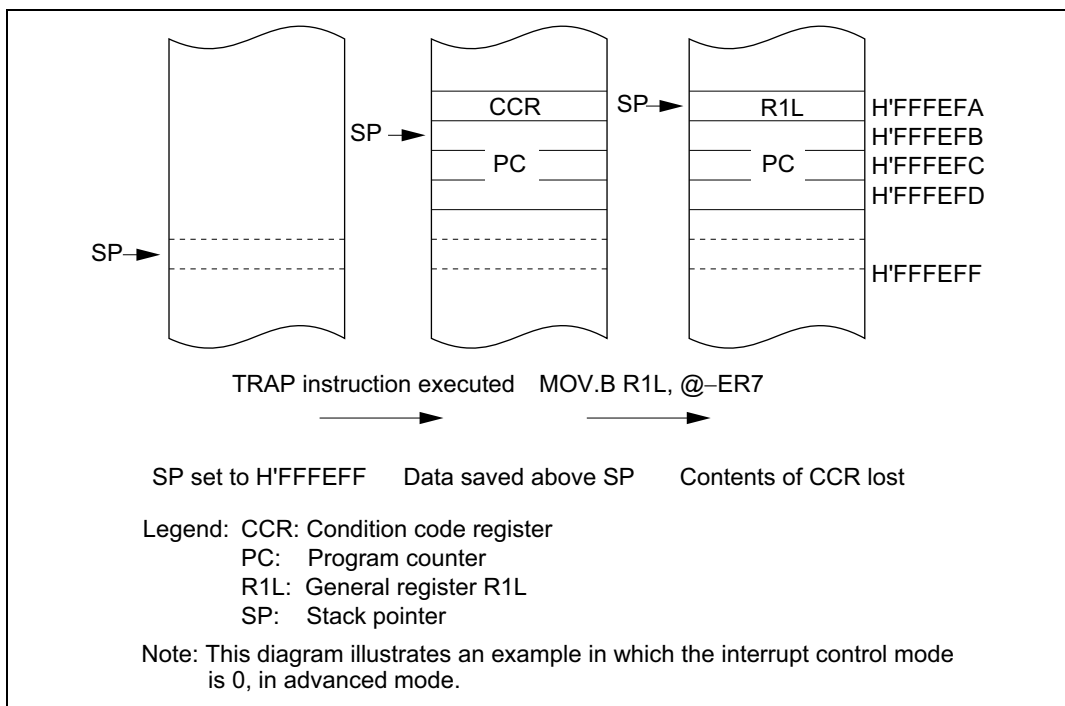

Figure 4-6 Operation when SP Value Is Odd

Section 5 Interrupt Controller

5.1 Overview

5.1.1 Features

The chip controls interrupts by means of an interrupt controller. The interrupt controller has the following features:

- Two interrupt control modes
 - Any of two interrupt control modes can be set by means of the INTM1 and INTM0 bits in the system control register (SYSCR).
- Priorities settable with IPR
 - An interrupt priority register (IPR) is provided for setting interrupt priorities. Eight priority levels can be set for each module for all interrupts except NMI.
 - NMI is assigned the highest priority level of 8, and can be accepted at all times.
- Independent vector addresses
 - All interrupt sources are assigned independent vector addresses, making it unnecessary for the source to be identified in the interrupt handling routine.
- Seven external interrupts
 - NMI is the highest-priority interrupt, and is accepted at all times. Rising edge or falling edge can be selected for NMI.
 - Falling edge, rising edge, or both edge detection, or level sensing, can be selected for IRQ5 to IRQ0.
- DTC control*
 - DTC activation is performed by means of interrupts.

Note: * The H8S/2635 Group is not equipped with a DTC.

5.1.2 Block Diagram

A block diagram of the interrupt controller is shown in figure 5-1.

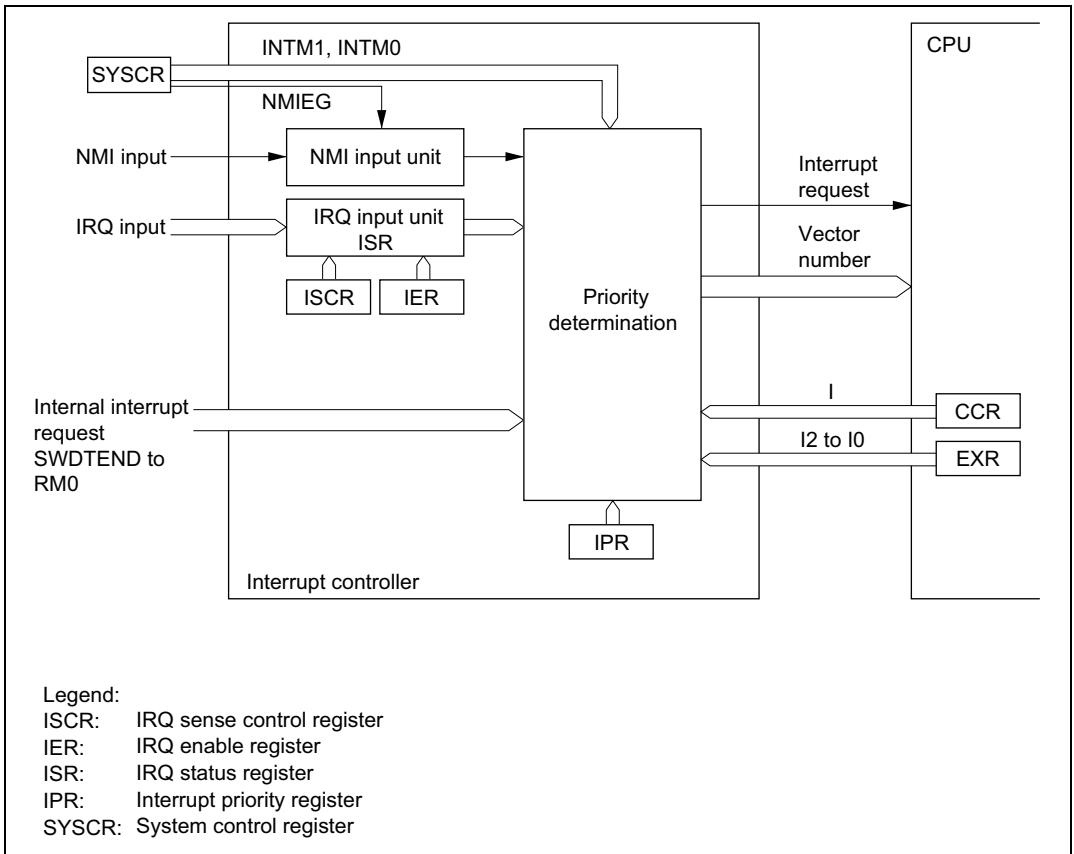

Figure 5-1 Block Diagram of Interrupt Controller

5.1.3 Pin Configuration

Table 5-1 summarizes the pins of the interrupt controller.

Table 5-1 Interrupt Controller Pins

Name	Symbol	I/O	Function
Nonmaskable interrupt	NMI	Input	Nonmaskable external interrupt; rising or falling edge can be selected
External interrupt requests 5 to 0	$\overline{IRQ5}$ to $\overline{IRQ0}$	Input	Maskable external interrupts; rising, falling, or both edges, or level sensing, can be selected

5.1.4 Register Configuration

Table 5-2 summarizes the registers of the interrupt controller.

Table 5-2 Interrupt Controller Registers

Name	Abbreviation	R/W	Initial Value	Address* ¹
System control register	SYSCR	R/W	H'01	H'FDE5
IRQ sense control register H	ISCRH	R/W	H'00	H'FE12
IRQ sense control register L	ISCLR	R/W	H'00	H'FE13
IRQ enable register	IER	R/W	H'00	H'FE14
IRQ status register	ISR	R/(W)* ²	H'00	H'FE15
Interrupt priority register A	IPRA	R/W	H'77	H'FEC0
Interrupt priority register B	IPRB	R/W	H'77	H'FEC1
Interrupt priority register C	IPRC	R/W	H'77	H'FEC2
Interrupt priority register D	IPRD	R/W	H'77	H'FEC3
Interrupt priority register E	IPRE	R/W	H'77	H'FEC4
Interrupt priority register F	IPRF	R/W	H'77	H'FEC5
Interrupt priority register G	IPRG	R/W	H'77	H'FEC6
Interrupt priority register H	IPRH	R/W	H'77	H'FEC7
Interrupt priority register J	IPRJ	R/W	H'77	H'FEC9
Interrupt priority register K	IPRK	R/W	H'77	H'FECA
Interrupt priority register L	IPRL	R/W	H'77	H'FECB
Interrupt priority register M	IPRM	R/W	H'77	H'FECC

Notes: 1. Lower 16 bits of the address.

2. Can only be written with 0 for flag clearing.

5.2 Register Descriptions

Note: The H8S/2635 Group is not equipped with a DTC, a PC brake controller, or an HCANI.

5.2.1 System Control Register (SYSCR)

Bit	:	7	6	5	4	3	2	1	0
		MACS	—	INTM1	INTM0	NMIEG	—	—	RAME
Initial value	:	0	0	0	0	0	0	0	1
R/W	:	R/W	—	R/W	R/W	R/W	R/W	—	R/W

SYSCR is an 8-bit readable/writable register that selects the interrupt control mode, and the detected edge for NMI.

Only bits 5 to 3 are described here; for details of the other bits, see section 3.2.2, System Control Register (SYSCR).

SYSCR is initialized to H'01 by a reset and in hardware standby mode. SYSCR is not initialized in software standby mode.

Bits 5 and 4—Interrupt Control Mode 1 and 0 (INTM1, INTM0): These bits select one of two interrupt control modes for the interrupt controller.

Bit 5 INTM1	Bit 4 INTM0	Interrupt Control Mode	Description
0	0	0	Interrupts are controlled by I bit (Initial value)
	1	—	Setting prohibited
1	0	2	Interrupts are controlled by bits I2 to I0, and IPR
	1	—	Setting prohibited

Bit 3—NMI Edge Select (NMIEG): Selects the input edge for the NMI pin.

Bit 3 NMIEG	Description
0	Interrupt request generated at falling edge of NMI input (Initial value)
1	Interrupt request generated at rising edge of NMI input

5.2.2 Interrupt Priority Registers A to H, J to M (IPRA to IPRH, IPRJ to IPRM)

Bit	:	7	6	5	4	3	2	1	0
		—	IPR6	IPR5	IPR4	—	IPR2	IPR1	IPR0
Initial value	:	0	1	1	1	0	1	1	1
R/W	:	—	R/W	R/W	R/W	—	R/W	R/W	R/W

The IPR registers are twelve 8-bit readable/writable registers that set priorities (levels 7 to 0) for interrupts other than NMI.

The correspondence between IPR settings and interrupt sources is shown in table 5-3.

The IPR registers set a priority (level 7 to 0) for each interrupt source other than NMI.

The IPR registers are initialized to H'77 by a reset and in hardware standby mode.

Bits 7 and 3—Reserved: These bits are always read as 0 and cannot be modified.

Table 5-3 Correspondence between Interrupt Sources and IPR Settings

Register	Bits	
	6 to 4	2 to 0
IPRA	IRQ0	IRQ1
IPRB	IRQ2	IRQ4
	IRQ3	IRQ5
IPRC	—*1	DTC*3
IPRD	Watchdog timer 0	—*1
IPRE	PC break*3	A/D converter, watchdog timer 1
IPRF	TPU channel 0	TPU channel 1
IPRG	TPU channel 2	TPU channel 3
IPRH	TPU channel 4	TPU channel 5
IPRJ	—*1	SCI channel 0
IPRK	SCI channel 1	SCI channel 2
IPRL	—*1	IIC (Option)*2
IPRM	PWM channel 1, 2	HCAN channel 0
	HCAN channel 1*3	

- Notes:
1. Reserved. These bits are always read as 1 and cannot be modified.
 2. I²C bus interface is available as an option in the H8S/2638, H8S/2639, and H8S/2630. The IIC bit becomes reserved bit when this optional feature is not used.
 3. The PC break, DTC, and HCAN channel 1 are reserved in the H8S/2635 Group.

As shown in table 5-3, multiple interrupts are assigned to one IPR. Setting a value in the range from H'0 to H'7 in the 3-bit groups of bits 6 to 4 and 2 to 0 sets the priority of the corresponding interrupt. The lowest priority level, level 0, is assigned by setting H'0, and the highest priority level, level 7, by setting H'7.

When interrupt requests are generated, the highest-priority interrupt according to the priority levels set in the IPR registers is selected. This interrupt level is then compared with the interrupt mask level set by the interrupt mask bits (I2 to I0) in the extend register (EXR) in the CPU, and if the priority level of the interrupt is higher than the set mask level, an interrupt request is issued to the CPU.

5.2.3 IRQ Enable Register (IER)

Bit	:	7	6	5	4	3	2	1	0
		—	—	IRQ5E	IRQ4E	IRQ3E	IRQ2E	IRQ1E	IRQ0E
Initial value	:	0	0	0	0	0	0	0	0
R/W	:	R/W	R/W	R/W	R/W	R/W	R/W	R/W	R/W

IER is an 8-bit readable/writable register that controls enabling and disabling of interrupt requests IRQ5 to IRQ0.

IER is initialized to H'00 by a reset and in hardware standby mode.

Bits 7 and 6—Reserved: These bits are always read as 0, and should only be written with 0.

Bits 5 to 0—IRQ5 to IRQ0 Enable (IRQ5E to IRQ0E): These bits select whether IRQ5 to IRQ0 are enabled or disabled.

Bit n

IRQnE	Description
0	IRQn interrupts disabled (Initial value)
1	IRQn interrupts enabled

(n = 5 to 0)

5.2.4 IRQ Sense Control Registers H and L (ISCRH, ISCRL)

ISCRH

Bit	:	15	14	13	12	11	10	9	8
		—	—	—	—	IRQ5SCB	IRQ5SCA	IRQ4SCB	IRQ4SCA
Initial value	:	0	0	0	0	0	0	0	0
R/W	:	R/W	R/W	R/W	R/W	R/W	R/W	R/W	R/W

ISCRL

Bit	:	7	6	5	4	3	2	1	0
		IRQ3SCB	IRQ3SCA	IRQ2SCB	IRQ2SCA	IRQ1SCB	IRQ1SCA	IRQ0SCB	IRQ0SCA
Initial value	:	0	0	0	0	0	0	0	0
R/W	:	R/W	R/W	R/W	R/W	R/W	R/W	R/W	R/W

The ISCR registers are 16-bit readable/writable registers that select rising edge, falling edge, or both edge detection, or level sensing, for the input at pins $\overline{\text{IRQ5}}$ to $\overline{\text{IRQ0}}$.

The ISCR registers are initialized to H'0000 by a reset and in hardware standby mode.

Bits 15 to 12—Reserved: These bits are always read as 0, and should only be written with 0.

Bits 11 to 0—IRQ5 Sense Control A and B (IRQ5SCA, IRQ5SCB) to IRQ0 Sense Control A and B (IRQ0SCA, IRQ0SCB)

Bits 11 to 0

IRQ5SCB to IRQ0SCB	IRQ5SCA to IRQ0SCA	Description
0	0	Interrupt request generated at $\overline{\text{IRQ5}}$ to $\overline{\text{IRQ0}}$ input low level (initial value)
	1	Interrupt request generated at falling edge of $\overline{\text{IRQ5}}$ to $\overline{\text{IRQ0}}$ input
1	0	Interrupt request generated at rising edge of $\overline{\text{IRQ5}}$ to $\overline{\text{IRQ0}}$ input
	1	Interrupt request generated at both falling and rising edges of $\overline{\text{IRQ5}}$ to $\overline{\text{IRQ0}}$ input

5.2.5 IRQ Status Register (ISR)

Bit	:	7	6	5	4	3	2	1	0
		—	—	IRQ5F	IRQ4F	IRQ3F	IRQ2F	IRQ1F	IRQ0F
Initial value	:	0	0	0	0	0	0	0	0
R/W	:	R/(W)*	R/(W)*	R/(W)*	R/(W)*	R/(W)*	R/(W)*	R/(W)*	R/(W)*

Note: * Only 0 can be written, to clear the flag.

ISR is an 8-bit readable/writable register that indicates the status of IRQ5 to IRQ0 interrupt requests.

ISR is initialized to H'00 by a reset and in hardware standby mode.

They are not initialized in software standby mode.

Bits 7 and 6—Reserved: These bits are always read as 0.

Bits 5 to 0—IRQ5 to IRQ0 Flags (IRQ5F to IRQ0F): These bits indicate the status of IRQ5 to IRQ0 interrupt requests.

Bit n

IRQnF	Description
0	<p>[Clearing conditions] (Initial value)</p> <ul style="list-style-type: none"> • Cleared by reading IRQnF flag when $IRQnF = 1$, then writing 0 to IRQnF flag • When interrupt exception handling is executed when low-level detection is set ($IRQnSCB = IRQnSCA = 0$) and \overline{IRQn} input is high • When IRQn interrupt exception handling is executed when falling, rising, or both-edge detection is set ($IRQnSCB = 1$ or $IRQnSCA = 1$) • When the DTC is activated by an IRQn interrupt, and the DISEL bit in MRB of the DTC is cleared to 0
1	<p>[Setting conditions]</p> <ul style="list-style-type: none"> • When \overline{IRQn} input goes low when low-level detection is set ($IRQnSCB = IRQnSCA = 0$) • When a falling edge occurs in \overline{IRQn} input when falling edge detection is set ($IRQnSCB = 0$, $IRQnSCA = 1$) • When a rising edge occurs in \overline{IRQn} input when rising edge detection is set ($IRQnSCB = 1$, $IRQnSCA = 0$) • When a falling or rising edge occurs in \overline{IRQn} input when both-edge detection is set ($IRQnSCB = IRQnSCA = 1$)

(n = 5 to 0)

5.3 Interrupt Sources

Interrupt sources comprise external interrupts (NMI and IRQ5 to IRQ0) and internal interrupts (49 sources).

Note: The H8S/2635 Group is not equipped with a DTC, a PC brake controller, or an HCAN1. The H8S/2635 Group has 45 sources of internal interrupt.

5.3.1 External Interrupts

There are seven external interrupts: NMI and IRQ5 to IRQ0. Of these, NMI and IRQ5 to IRQ0 can be used to restore the chip from software standby mode.

NMI Interrupt: NMI is the highest-priority interrupt, and is always accepted by the CPU regardless of the interrupt control mode or the status of the CPU interrupt mask bits. The NMIEG bit in SYSCR can be used to select whether an interrupt is requested at a rising edge or a falling edge on the NMI pin.

The vector number for NMI interrupt exception handling is 7.

IRQ5 to IRQ0 Interrupts: Interrupts IRQ5 to IRQ0 are requested by an input signal at pins $\overline{\text{IRQ5}}$ to $\overline{\text{IRQ0}}$. Interrupts IRQ5 to IRQ0 have the following features:

- Using ISCR, it is possible to select whether an interrupt is generated by a low level, falling edge, rising edge, or both edges, at pins $\overline{\text{IRQ5}}$ to $\overline{\text{IRQ0}}$.
- Enabling or disabling of interrupt requests IRQ5 to IRQ0 can be selected with IER.
- The interrupt priority level can be set with IPR.
- The status of interrupt requests IRQ5 to IRQ0 is indicated in ISR. ISR flags can be cleared to 0 by software.

A block diagram of interrupts IRQ5 to IRQ0 is shown in figure 5-2.

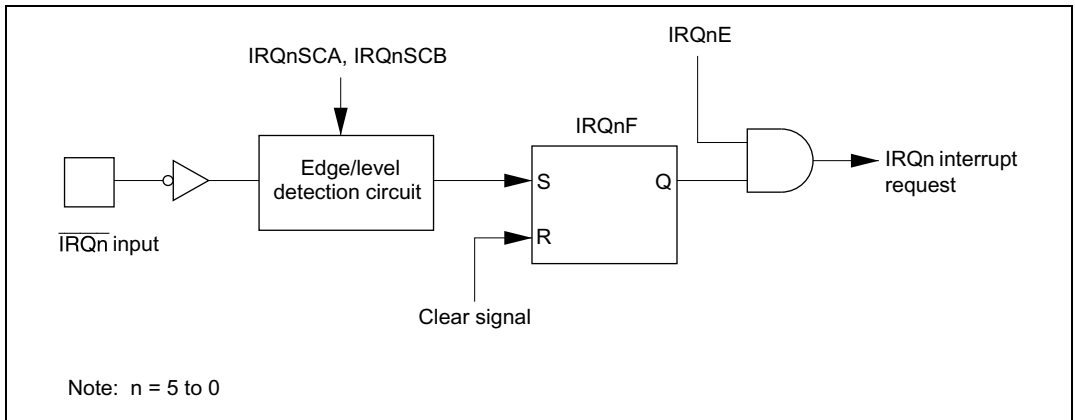

Figure 5-2 Block Diagram of Interrupts IRQ5 to IRQ0

Figure 5-3 shows the timing of setting IRQnF .

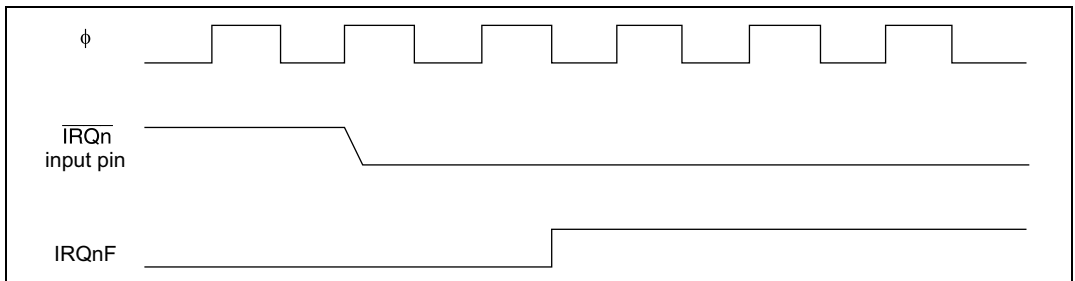

Figure 5-3 Timing of Setting IRQnF

The vector numbers for IRQ5 to IRQ0 interrupt exception handling are 21 to 16.

Detection of IRQ5 to IRQ0 interrupts does not depend on whether the relevant pin has been set for input or output. However, when a pin is used as an external interrupt input pin, do not clear the corresponding DDR to 0 and use the pin as an I/O pin for another function.

5.3.2 Internal Interrupts

There are 49 sources for internal interrupts from on-chip supporting modules.

- For each on-chip supporting module there are flags that indicate the interrupt request status, and enable bits that select enabling or disabling of these interrupts. If both of these are set to 1 for a particular interrupt source, an interrupt request is issued to the interrupt controller.
- The interrupt priority level can be set by means of IPR.
- The DTC can be activated by a TPU, SCI, or other interrupt request. When the DTC is activated by an interrupt, the interrupt control mode and interrupt mask bits are not affected.

5.3.3 Interrupt Exception Handling Vector Table

Table 5-4 shows interrupt exception handling sources, vector addresses, and interrupt priorities. For default priorities, the lower the vector number, the higher the priority.

Priorities among modules can be set by means of the IPR. The situation when two or more modules are set to the same priority, and priorities within a module, are fixed as shown in table 5-4.

Table 5-4 Interrupt Sources, Vector Addresses, and Interrupt Priorities

Interrupt Source	Origin of Interrupt Source	Vector Number	Vector Address*1		Priority
			Advanced Mode	IPR	
NMI	External pin	7	H'001C		High ↑
IRQ0		16	H'0040	IPRA6 to 4	
IRQ1	17	H'0044	IPRA2 to 0		
IRQ2	18	H'0048	IPRB6 to 4		
IRQ3	19	H'004C			
IRQ4	20	H'0050	IPRB2 to 0		
IRQ5	21	H'0054			
Reserved for system use	—	22 23	H'0058 H'005C	—	
SWDTEND (software activation interrupt end)	DTC*3	24	H'0060	IPRC2 to 0	
WOVI0 (interval timer)	Watchdog timer 0	25	H'0064	IPRD6 to 4	
Reserved for system use	—	26	H'0068	—	
PC break	PC break controller*3	27	H'006C	IPRE6 to 4	
ADI (A/D conversion end)	A/D	28	H'0070	IPRE2 to 0	
WOVI1 (interval timer)	Watchdog timer 1	29	H'0074		
Reserved for system use	—	30 31	H'0078 H'007C	—	
TGI0A (TGR0A input capture/compare match)	TPU channel 0	32	H'0080	IPRF6 to 4	
TGI0B (TGR0B input capture/compare match)		33	H'0084		
TGI0C (TGR0C input capture/compare match)		34	H'0088		
TGI0D (TGR0D input capture/compare match)		35	H'008C		
TCI0V (overflow 0)		36	H'0090		
Reserved for system use		—	37 to 39	H'0094 to H'009C	—
					Low

Interrupt Source	Origin of Interrupt Source	Vector Number	Vector Address* ¹	IPR	Priority
			Advanced Mode		
PWM1	PWM channel 1	104	H'01A0	IPRM6 to 4	High ↑ Low
PWM2	PWM channel 2	105	H'01A4		
ERS0, OVR0, RM1, SLE0, RM0	HCAN1* ³	106	H'01A8		
		107	H'01AC		
ERS0, OVR0, RM1, SLE0, RM0	HCAN0	108	H'01B0	IPRM2 to 0	
		109	H'01B4		
Reserved for system use	—	110	H'01B8		
		111	H'01BC		

Notes: 1. Lower 16 bits of the start address.

2. I²C is available as an option in the H8S/2638, H8S/2639, and H8S/2630 only. The product equipped with the I²C bus interface is the W-mask version.

3. The DTC, PC break, and HCAN1 interrupts are reserved in the H8S/2635 Group.

5.4 Interrupt Operation

5.4.1 Interrupt Control Modes and Interrupt Operation

Interrupt operations in the chip differ depending on the interrupt control mode.

NMI interrupts are accepted at all times except in the reset state and the hardware standby state. In the case of IRQ interrupts and on-chip supporting module interrupts, an enable bit is provided for each interrupt. Clearing an enable bit to 0 disables the corresponding interrupt request. Interrupt sources for which the enable bits are set to 1 are controlled by the interrupt controller.

Table 5-5 shows the interrupt control modes.

The interrupt controller performs interrupt control according to the interrupt control mode set by the INTM1 and INTM0 bits in SYSCR, the priorities set in IPR, and the masking state indicated by the I bit in the CPU's CCR, and bits I2 to I0 in EXR.

Table 5-5 Interrupt Control Modes

Interrupt Control Mode	SYSCR		Priority Setting Registers	Interrupt Mask Bits	Description
	INTM1	INTM0			
0	0	0	—	I	Interrupt mask control is performed by the I bit.
—	—	1	—	—	Setting prohibited
2	1	0	IPR	I2 to I0	8-level interrupt mask control is performed by bits I2 to I0. 8 priority levels can be set with IPR.
—	—	1	—	—	Setting prohibited

Figure 5-4 shows a block diagram of the priority decision circuit.

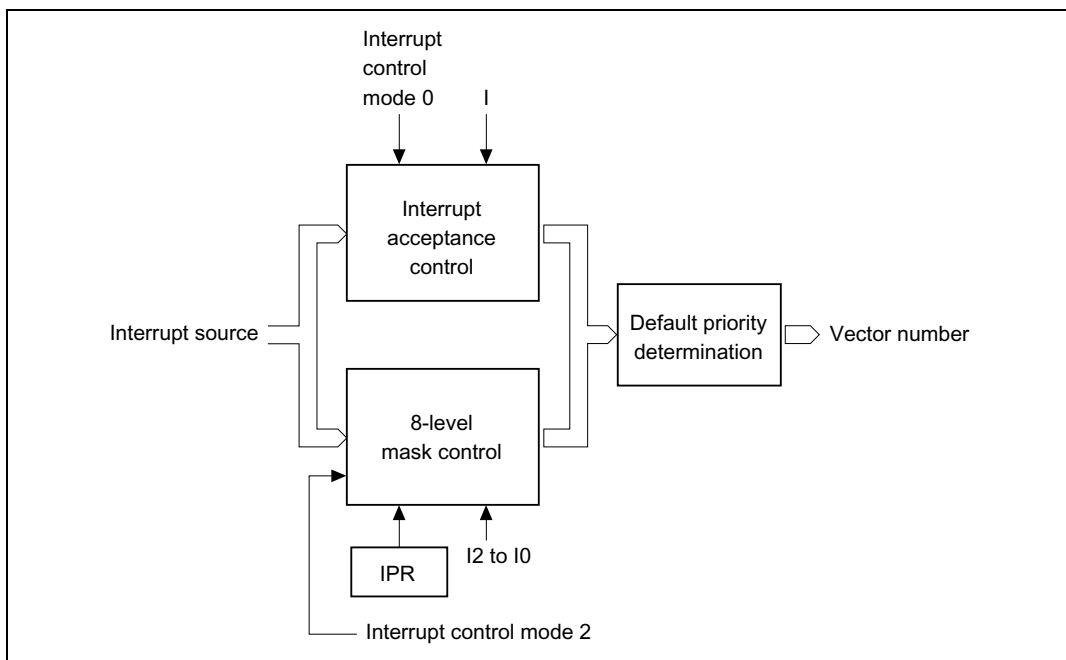
**Figure 5-4 Block Diagram of Interrupt Control Operation**

(1) Interrupt Acceptance Control

In interrupt control mode 0, interrupt acceptance is controlled by the I bit in CCR.

Table 5-6 shows the interrupts selected in each interrupt control mode.

Table 5-6 Interrupts Selected in Each Interrupt Control Mode (1)

Interrupt Control Mode	Interrupt Mask Bits	
	I	Selected Interrupts
0	0	All interrupts
	1	NMI interrupts
2	*	All interrupts

Legend:

*: Don't care

(2) 8-Level Control

In interrupt control mode 2, 8-level mask level determination is performed for the selected interrupts in interrupt acceptance control according to the interrupt priority level (IPR).

The interrupt source selected is the interrupt with the highest priority level, and whose priority level set in IPR is higher than the mask level.

Table 5-7 Interrupts Selected in Each Interrupt Control Mode (2)

Interrupt Control Mode	Selected Interrupts
0	All interrupts
2	Highest-priority-level (IPR) interrupt whose priority level is greater than the mask level (IPR > I2 to I0).

(3) Default Priority Determination

When an interrupt is selected by 8-level control, its priority is determined and a vector number is generated.

If the same value is set for IPR, acceptance of multiple interrupts is enabled, and so only the interrupt source with the highest priority according to the preset default priorities is selected and has a vector number generated.

Interrupt sources with a lower priority than the accepted interrupt source are held pending.

Table 5-8 shows operations and control signal functions in each interrupt control mode.

Table 5-8 Operations and Control Signal Functions in Each Interrupt Control Mode

Interrupt Control	Setting		Interrupt Acceptance Control		8-Level Control			Default Priority Determination	T (Trace)
	Mode	INTM1	INTM0	I	I2 to I0	IPR			
0	0	0	○	IM	X	—	—*2	○	—
2	1	0	X	—*1	○	IM	PR	○	T

Legend:

- : Interrupt operation control performed
- X: No operation (All interrupts enabled).
- IM: Used as interrupt mask bit
- PR: Sets priority.
- : Not used.

Notes: 1. Set to 1 when interrupt is accepted.
2. Keep the initial setting.

5.4.2 Interrupt Control Mode 0

Enabling and disabling of IRQ interrupts and on-chip supporting module interrupts can be set by means of the I bit in the CPU's CCR. Interrupts are enabled when the I bit is cleared to 0, and disabled when set to 1.

Figure 5-5 shows a flowchart of the interrupt acceptance operation in this case.

- [1] If an interrupt source occurs when the corresponding interrupt enable bit is set to 1, an interrupt request is sent to the interrupt controller.
- [2] The I bit is then referenced. If the I bit is cleared to 0, the interrupt request is accepted. If the I bit is set to 1, only an NMI interrupt is accepted, and other interrupt requests are held pending.
- [3] Interrupt requests are sent to the interrupt controller, the highest-ranked interrupt according to the priority system is accepted, and other interrupt requests are held pending.
- [4] When an interrupt request is accepted, interrupt exception handling starts after execution of the current instruction has been completed.
- [5] The PC and CCR are saved to the stack area by interrupt exception handling. The PC saved on the stack shows the address of the first instruction to be executed after returning from the interrupt handling routine.
- [6] Next, the I bit in CCR is set to 1. This masks all interrupts except NMI.
- [7] A vector address is generated for the accepted interrupt, and execution of the interrupt handling routine starts at the address indicated by the contents of that vector address.

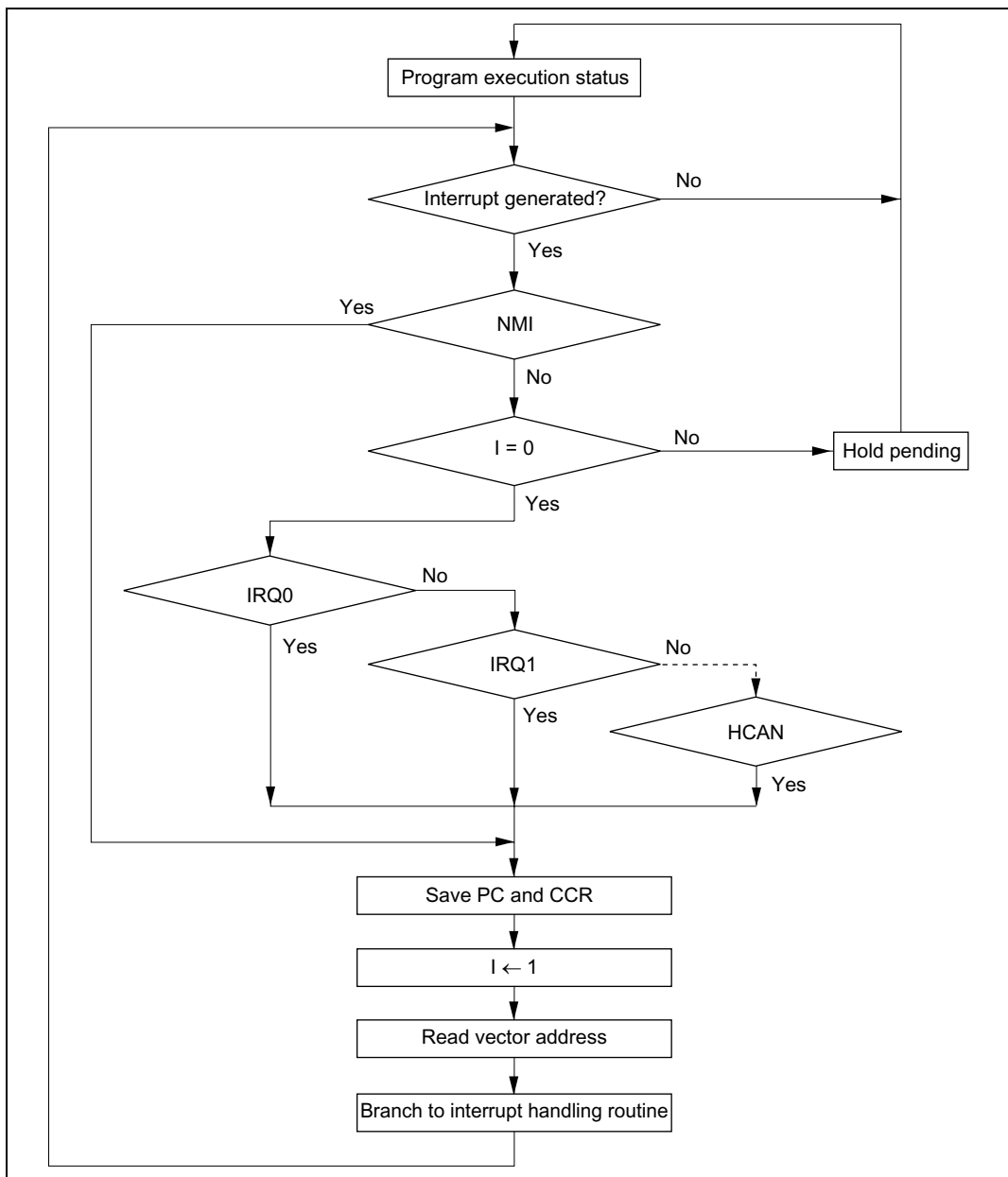

Figure 5-5 Flowchart of Procedure Up to Interrupt Acceptance in Interrupt Control Mode 0

5.4.3 Interrupt Control Mode 2

Eight-level masking is implemented for IRQ interrupts and on-chip supporting module interrupts by comparing the interrupt mask level set by bits I2 to I0 of EXR in the CPU with IPR.

Figure 5-6 shows a flowchart of the interrupt acceptance operation in this case.

- [1] If an interrupt source occurs when the corresponding interrupt enable bit is set to 1, an interrupt request is sent to the interrupt controller.
- [2] When interrupt requests are sent to the interrupt controller, the interrupt with the highest priority according to the interrupt priority levels set in IPR is selected, and lower-priority interrupt requests are held pending. If a number of interrupt requests with the same priority are generated at the same time, the interrupt request with the highest priority according to the priority system shown in table 5-4 is selected.
- [3] Next, the priority of the selected interrupt request is compared with the interrupt mask level set in EXR. An interrupt request with a priority no higher than the mask level set at that time is held pending, and only an interrupt request with a priority higher than the interrupt mask level is accepted.
- [4] When an interrupt request is accepted, interrupt exception handling starts after execution of the current instruction has been completed.
- [5] The PC, CCR, and EXR are saved to the stack area by interrupt exception handling. The PC saved on the stack shows the address of the first instruction to be executed after returning from the interrupt handling routine.
- [6] The T bit in EXR is cleared to 0. The interrupt mask level is rewritten with the priority level of the accepted interrupt.
If the accepted interrupt is NMI, the interrupt mask level is set to H'7.
- [7] A vector address is generated for the accepted interrupt, and execution of the interrupt handling routine starts at the address indicated by the contents of that vector address.

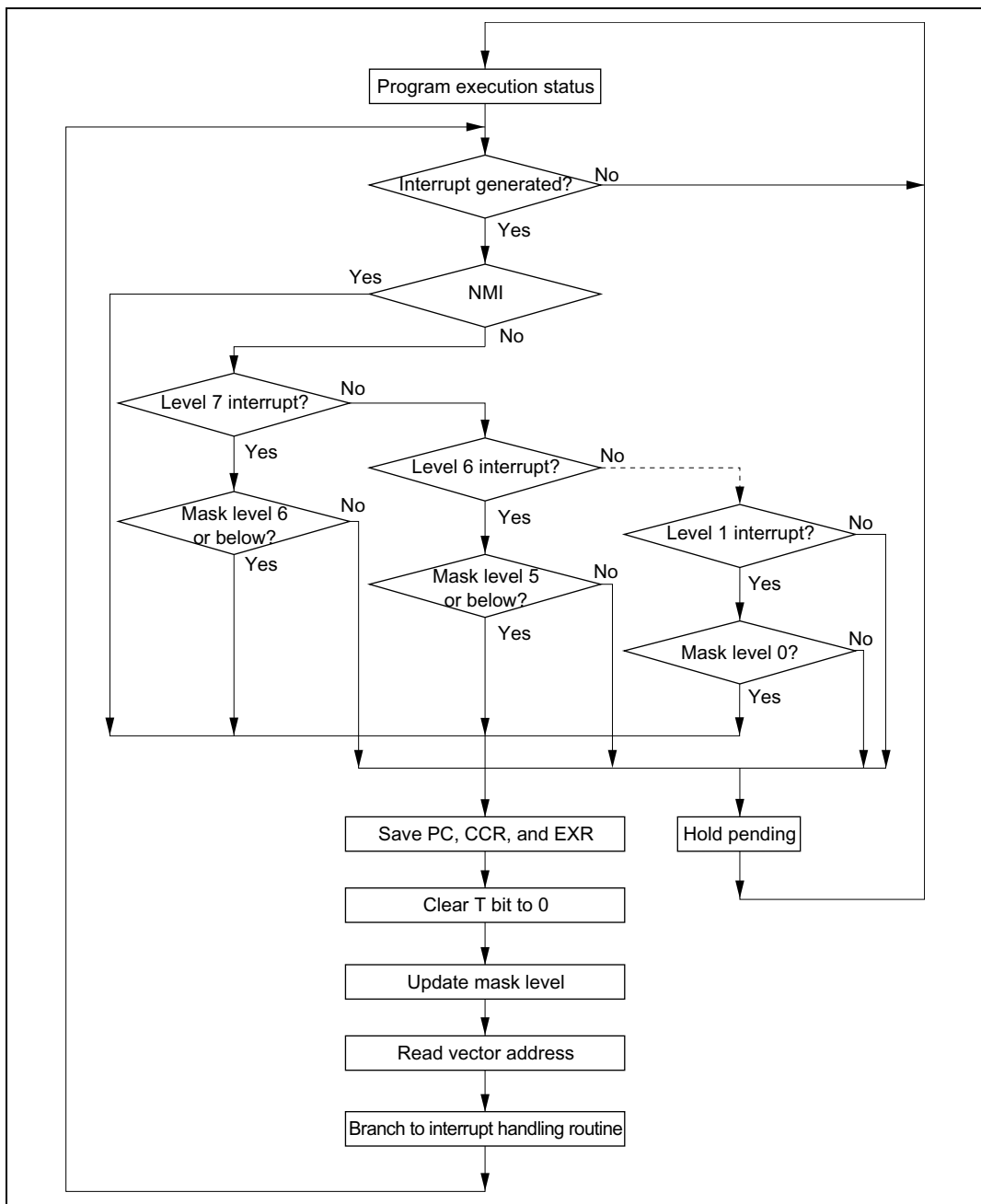

Figure 5-6 Flowchart of Procedure Up to Interrupt Acceptance in Interrupt Control Mode 2

5.4.4 Interrupt Exception Handling Sequence

Figure 5-7 shows the interrupt exception handling sequence. The example shown is for the case where interrupt control mode 0 is set in advanced mode, and the program area and stack area are in on-chip memory.

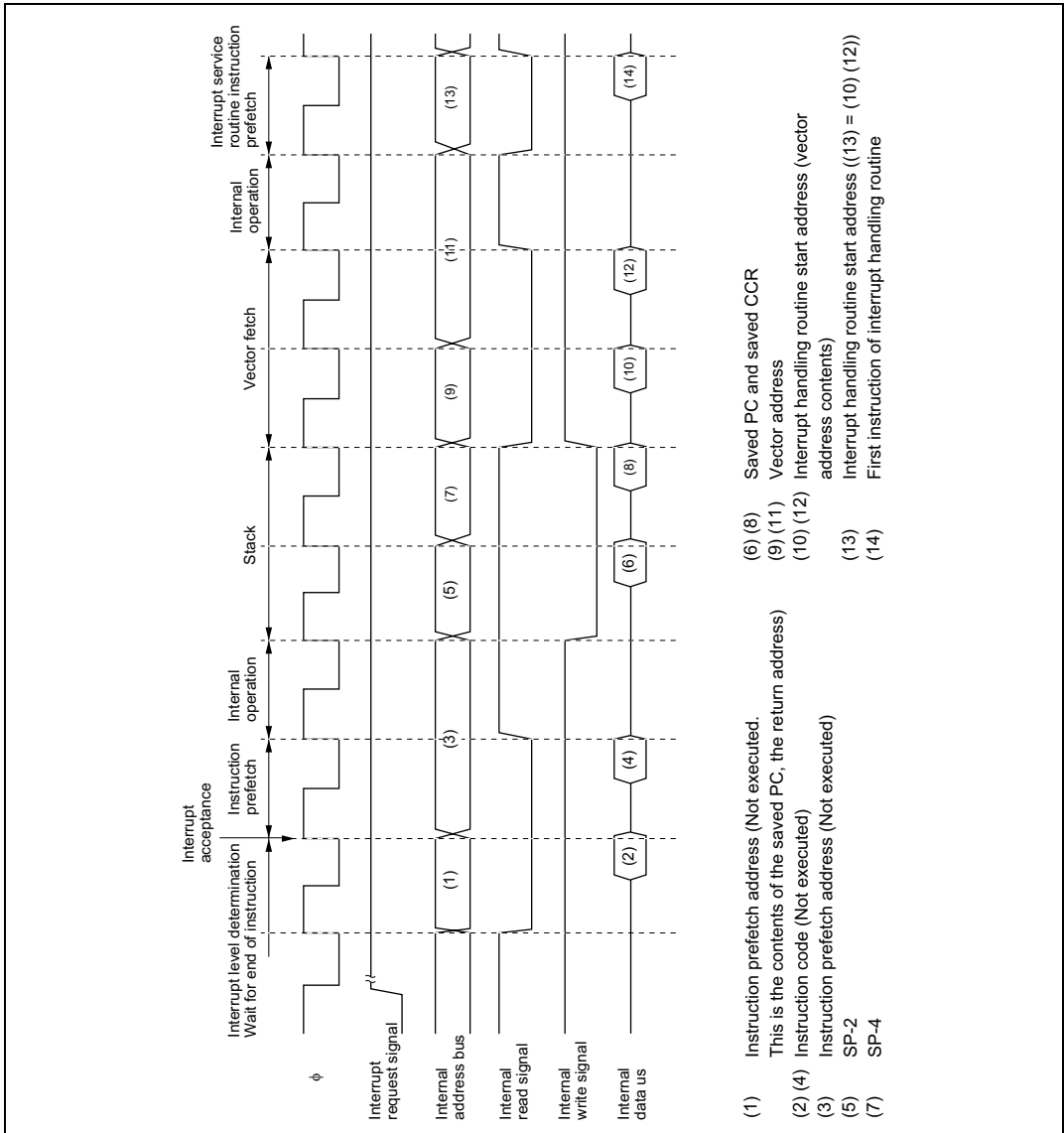

Figure 5-7 Interrupt Exception Handling

5.4.5 Interrupt Response Times

The chip is capable of fast word transfer instruction to on-chip memory, and the program area is provided in on-chip ROM and the stack area in on-chip RAM, enabling high-speed processing.

Table 5-9 shows interrupt response times - the interval between generation of an interrupt request and execution of the first instruction in the interrupt handling routine. The execution status symbols used in table 5-9 are explained in table 5-10.

Table 5-9 Interrupt Response Times

No.	Execution Status	Normal Mode ^{*5}		Advanced Mode	
		INTM1 = 0	INTM1 = 1	INTM1 = 0	INTM1 = 1
1	Interrupt priority determination ^{*1}	3	3	3	3
2	Number of wait states until executing instruction ends ^{*2}	1 to (19 + 2 · S _I)	1 to (19 + 2 · S _I)	1 to (19 + 2 · S _I)	1 to (19 + 2 · S _I)
3	PC, CCR, EXR stack save	2 · S _K	3 · S _K	2 · S _K	3 · S _K
4	Vector fetch	S _I	S _I	2 · S _I	2 · S _I
5	Instruction fetch ^{*3}	2 · S _I	2 · S _I	2 · S _I	2 · S _I
6	Internal processing ^{*4}	2	2	2	2
Total (using on-chip memory)		11 to 31	12 to 32	12 to 32	13 to 33

Notes: 1. Two states in case of internal interrupt.

2. Refers to MULXS and DIVXS instructions.

3. Prefetch after interrupt acceptance and interrupt handling routine prefetch.

4. Internal processing after interrupt acceptance and internal processing after vector fetch.

5. Not implemented in the chip.

Table 5-10 Number of States in Interrupt Handling Routine Execution Statuses

Symbol		Object of Access				
		Internal Memory	External Device			
			8 Bit Bus		16 Bit Bus	
			2-State Access	3-State Access	2-State Access	3-State Access
Instruction fetch	S _I	1	4	6 + 2m	2	3 + m
Branch address read	S _J					
Stack manipulation	S _K					

Legend:

m: Number of wait states in an external device access.

5.5 Usage Notes

5.5.1 Contention between Interrupt Generation and Disabling

When an interrupt enable bit is cleared to 0 to disable interrupts, the disabling becomes effective after execution of the instruction.

In other words, when an interrupt enable bit is cleared to 0 by an instruction such as BCLR or MOV, if an interrupt is generated during execution of the instruction, the interrupt concerned will still be enabled on completion of the instruction, and so interrupt exception handling for that interrupt will be executed on completion of the instruction. However, if there is an interrupt request of higher priority than that interrupt, interrupt exception handling will be executed for the higher-priority interrupt, and the lower-priority interrupt will be ignored.

The same also applies when an interrupt source flag is cleared to 0.

Figure 5-8 shows an example in which the TCIEV bit in the TPU's TIER register is cleared to 0.

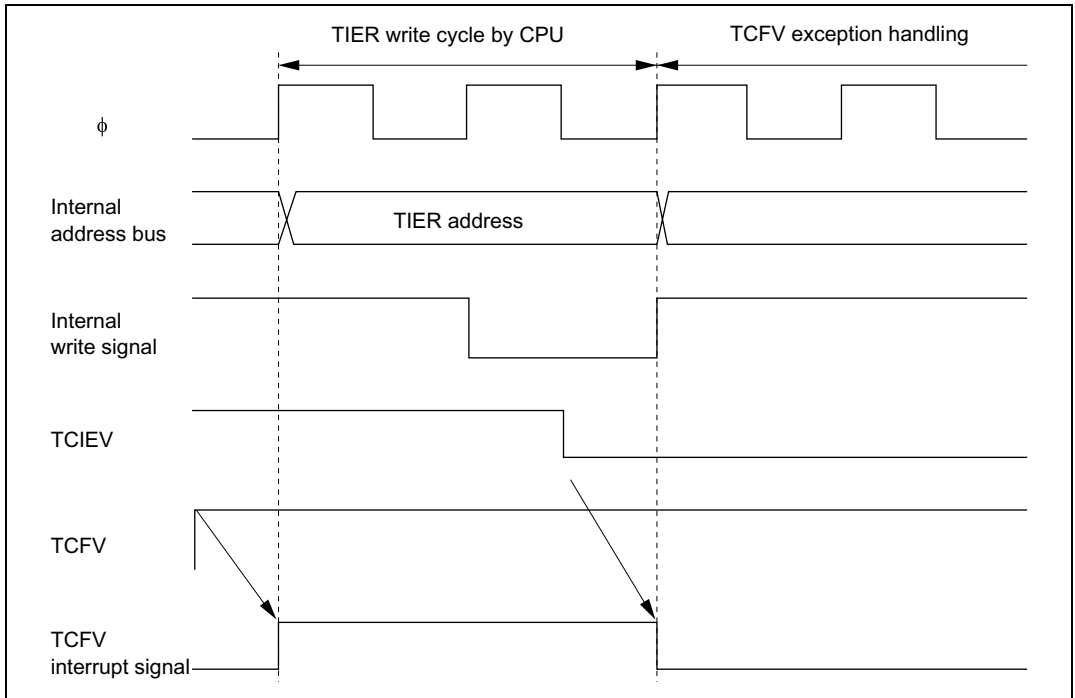

Figure 5-8 Contention between Interrupt Generation and Disabling

The above contention will not occur if an enable bit or interrupt source flag is cleared to 0 while the interrupt is masked.

5.5.2 Instructions that Disable Interrupts

Instructions that disable interrupts are LDC, ANDC, ORC, and XORC. After any of these instructions is executed, all interrupts including NMI are disabled and the next instruction is always executed. When the I bit is set by one of these instructions, the new value becomes valid two states after execution of the instruction ends.

5.5.3 Times when Interrupts Are Disabled

There are times when interrupt acceptance is disabled by the interrupt controller.

The interrupt controller disables interrupt acceptance for a 3-state period after the CPU has updated the mask level with an LDC, ANDC, ORC, or XORC instruction.

5.5.4 Interrupts during Execution of EEPMOV Instruction

Interrupt operation differs between the EEPMOV.B instruction and the EEPMOV.W instruction.

With the EEPMOV.B instruction, an interrupt request (including NMI) issued during the transfer is not accepted until the move is completed.

With the EEPMOV.W instruction, if an interrupt request is issued during the transfer, interrupt exception handling starts at a break in the transfer cycle. The PC value saved on the stack in this case is the address of the next instruction.

Therefore, if an interrupt is generated during execution of an EEPMOV.W instruction, the following coding should be used.

```
L1 :   EEPMOV.W
      MOV.W   R4, R4
      BNE    L1
```

5.5.5 IRQ Interrupts

When operating by clock input, acceptance of input to an $\overline{\text{IRQ}}$ pin is synchronized with the clock. In software standby mode, the input is accepted asynchronously. For details on the input conditions, see section 24.5.2, Control Signal Timing.

5.5.6 Notes on Use of NMI Interrupt

When the system is operating normally under conditions conforming to the specified electrical properties, exception processing by the on-chip interrupt controller linked to the CPU is used to execute the NMI interrupt. When operation is not normal (runaway status) due to a software problem or abnormal input to one of the LSI's pins, no operations can be guaranteed, including the NMI interrupt. In such cases it is possible to cause the LSI to return to normal program execution by applying an external reset.

5.6 DTC Activation by Interrupt

Note: The DTC is not implemented in the H8S/2635 Group.

5.6.1 Overview

The DTC can be activated by an interrupt. In this case, the following options are available:

- Interrupt request to CPU
- Activation request to DTC
- Selection of a number of the above

For details of interrupt requests that can be used with to activate the DTC, see section 8, Data Transfer Controller (DTC).

5.6.2 Block Diagram

Figure 5-9 shows a block diagram of the DTC interrupt controller.

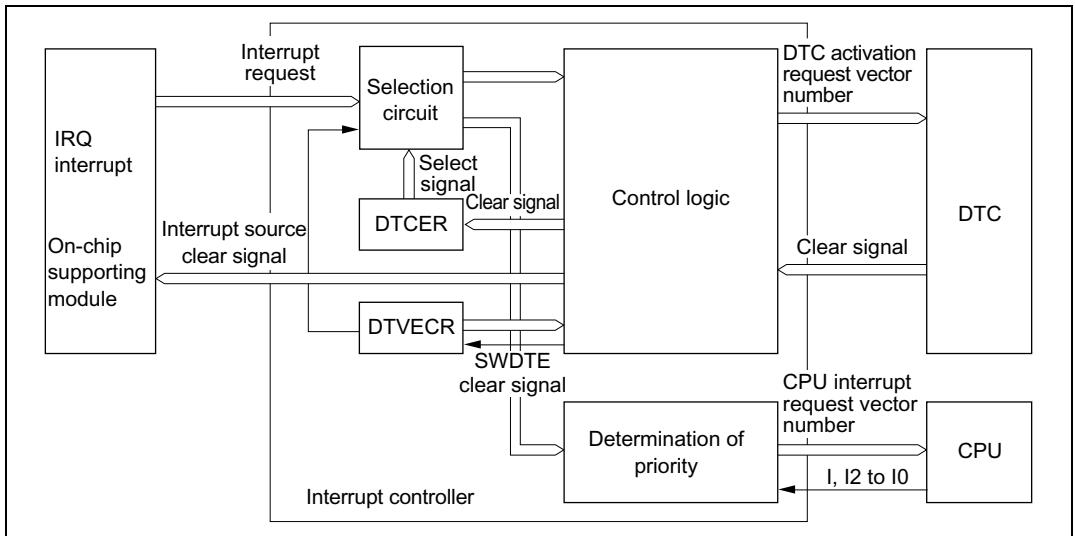

Figure 5-9 Interrupt Control for DTC

5.6.3 Operation

The interrupt controller has three main functions in DTC control.

(1) Selection of Interrupt Source: Interrupt factors are selected as DTC activation request or CPU interrupt request by the DTCE bit of DTCERA to DTCERG of DTC.

By specifying the DISEL bit of the DTC's MRB, it is possible to clear the DTCE bit to 0 after DTC data transfer, and request a CPU interrupt.

If DTC carries out the designate number of data transfers and the transfer counter reads 0, after DTC data transfer, the DTCE bit is also cleared to 0, and a CPU interrupt requested.

(2) Determination of Priority: The DTC activation source is selected in accordance with the default priority order, and is not affected by mask or priority levels. See section 8.3.3, DTC Vector Table for the respective priority.

(3) Operation Order: If the same interrupt is selected as a DTC activation source and a CPU interrupt source, the DTC data transfer is performed first, followed by CPU interrupt exception handling.

Table 5-11 shows the interrupt factor clear control and selection of interrupt factors by specification of the DTCE bit of DTCERA to DTCERG of DTC, and the DISEL bit of DTC's MRB.

Table 5-11 Interrupt Source Selection and Clearing Control

Settings		Interrupt Source Selection/Clearing Control	
DTC		Interrupt Source Selection/Clearing Control	
DTCE	DISEL	DTC	CPU
0	*	X	△
1	0	△	X
	1	○	△

Legend:

- △ : The relevant interrupt is used. Interrupt source clearing is performed.
(The CPU should clear the source flag in the interrupt handling routine.)
- : The relevant interrupt is used. The interrupt source is not cleared.
- X : The relevant bit cannot be used.
- * : Don't care

(4) Notes on Use: SCI and A/D converter interrupt sources are cleared when the DTC reads or writes to the prescribed register.

Section 6 PC Break Controller (PBC)

Note: The H8S/2635 Group is not equipped with a PBC.

6.1 Overview

The PC break controller (PBC) provides functions that simplify program debugging. Using these functions, it is easy to create a self-monitoring debugger, enabling programs to be debugged with the chip alone, without using an in-circuit emulator. Four break conditions can be set in the PBC: instruction fetch, data read, data write, and data read/write.

6.1.1 Features

The PC break controller has the following features:

- Two break channels (A and B)
- The following can be set as break compare conditions:
 - 24 address bits
 - Bit masking possible
 - Bus cycle
 - Instruction fetch
 - Data access: data read, data write, data read/write
 - Bus master
 - Either CPU or CPU/DTC can be selected
- The timing of PC break exception handling after the occurrence of a break condition is as follows:
 - Immediately before execution of the instruction fetched at the set address (instruction fetch)
 - Immediately after execution of the instruction that accesses data at the set address (data access)
- Module stop mode can be set
 - The initial setting is for PBC operation to be halted. Register access is enabled by clearing module stop mode.

6.1.2 Block Diagram

Figure 6-1 shows a block diagram of the PC break controller.

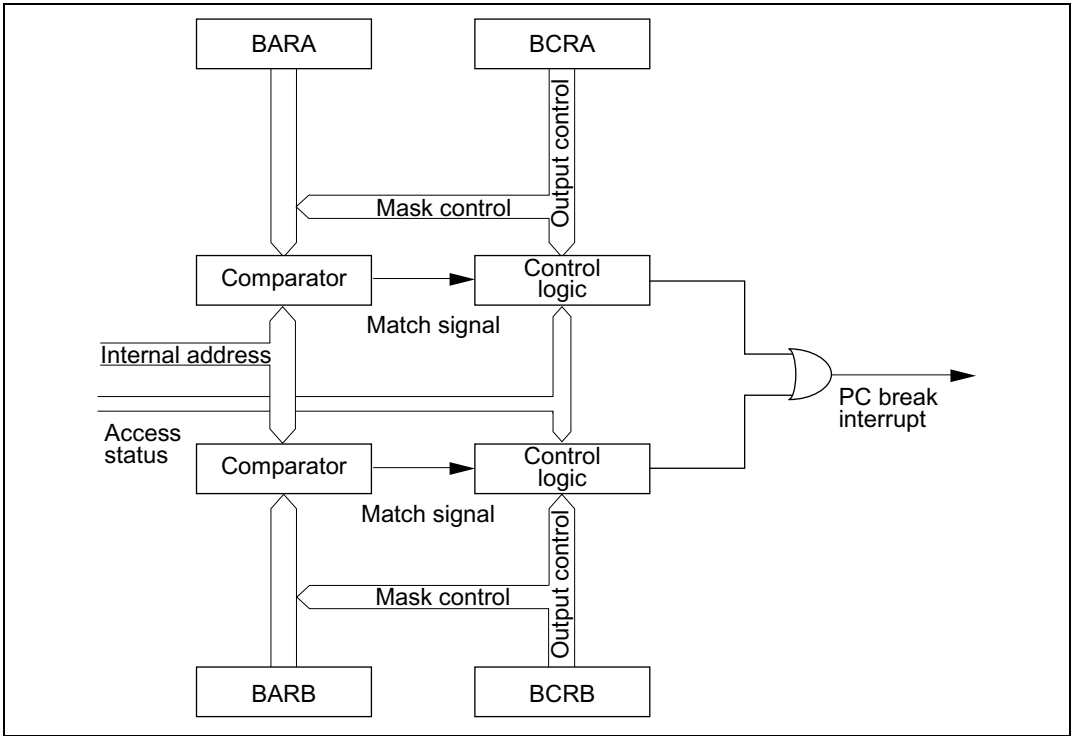

Figure 6-1 Block Diagram of PC Break Controller

6.1.3 Register Configuration

Table 6-1 shows the PC break controller registers.

Table 6-1 PC Break Controller Registers

Name	Abbreviation	R/W	Initial Value	
			Reset	Address* ¹
Break address register A	BARA	R/W	H'XX000000	H'FE00
Break address register B	BARB	R/W	H'XX000000	H'FE04
Break control register A	BCRA	R/(W)* ²	H'00	H'FE08
Break control register B	BCRB	R/(W)* ²	H'00	H'FE09
Module stop control register C	MSTPCRC	R/W	H'FF	H'FDEA

Notes: 1. Lower 16 bits of the address.

2. Only a 0 may be written to this bit to clear the flag.

6.2 Register Descriptions

6.2.1 Break Address Register A (BARA)

Bit	31	...	24	23	22	21	20	19	18	17	16	...	7	6	5	4	3	2	1	0
	—	...	—	BAA	BAA	BAA	BAA	BAA	BAA	BAA	BAA	...	BAA	BAA	BAA	BAA	BAA	BAA	BAA	BAA
Initial value	Unde-	...	Unde-	0	0	0	0	0	0	0	0	...	0	0	0	0	0	0	0	0
Read/Write	—	...	—	R/W	R/W	R/W	R/W	R/W	R/W	R/W	R/W	...	R/W	R/W	R/W	R/W	R/W	R/W	R/W	R/W

BARA is a 32-bit readable/writable register that specifies the channel A break address.

BAA23 to BAA0 are initialized to H'000000 by a reset and in hardware standby mode.

Bits 31 to 24—Reserved: These bits return an undefined value if read, and cannot be modified.

Bits 23 to 0—Break Address A23 to A0 (BAA23 to BAA0): These bits hold the channel A PC break address.

6.2.2 Break Address Register B (BARB)

BARB is the channel B break address register. The bit configuration is the same as for BARA.

6.2.3 Break Control Register A (BCRA)

Bit	7	6	5	4	3	2	1	0
	CMFA	CDA	BAMRA2	BAMRA1	BAMRA0	CSELA1	CSELA0	BIEA
Initial value	0	0	0	0	0	0	0	0
Read/Write	R/(W)*	R/W	R/W	R/W	R/W	R/W	R/W	R/W

Note: * Only a 0 may be written to this bit to clear the flag.

BCRA is an 8-bit readable/writable register that controls channel A PC breaks. BCRA (1) selects the break condition bus master, (2) specifies bits subject to address comparison masking, and (3) specifies whether the break condition is applied to an instruction fetch or a data access. It also contains a condition match flag.

BCRA is initialized to H'00 by a reset and in hardware standby mode.

Bit 7—Condition Match Flag A (CMFA): Set to 1 when a break condition set for channel A is satisfied. This flag is not cleared to 0.

Bit 7

CMFA	Description
0	[Clearing condition] <ul style="list-style-type: none"> When 0 is written to CMFA after reading CMFA = 1 (Initial value)
1	[Setting condition] <ul style="list-style-type: none"> When a condition set for channel A is satisfied

Bit 6—CPU Cycle/DTC Cycle Select A (CDA): Selects the channel A break condition bus master.

Bit 6

CDA	Description
0	PC break is performed when CPU is bus master (Initial value)
1	PC break is performed when CPU or DTC is bus master

Bits 5 to 3—Break Address Mask Register A2 to A0 (BAMRA2 to BAMRA0): These bits specify which bits of the break address (BAA23 to BAA0) set in BARA are to be masked.

Bit 5	Bit 4	Bit 3	Description	
0	0	0	All BARA bits are unmasked and included in break conditions (Initial value)	
		1	BAA0 (lowest bit) is masked, and not included in break conditions	
	1	0	BAA1, BAA0 (lower 2 bits) are masked, and not included in break conditions	
		1	BAA2 to BAA0 (lower 3 bits) are masked, and not included in break conditions	
	1	0	0	BAA3 to BAA0 (lower 4 bits) are masked, and not included in break conditions
			1	BAA7 to BAA0 (lower 8 bits) are masked, and not included in break conditions
1		0	BAA11 to BAA0 (lower 12 bits) are masked, and not included in break conditions	
		1	BAA15 to BAA0 (lower 16 bits) are masked, and not included in break conditions	

Bits 2 and 1—Break Condition Select A (CSELA1, CSELA0): These bits selection an instruction fetch, data read, data write, or data read/write cycle as the channel A break condition.

Bit 2	Bit 1		
CSELA1	CSELA0	Description	
0	0	Instruction fetch is used as break condition	(Initial value)
	1	Data read cycle is used as break condition	
1	0	Data write cycle is used as break condition	
	1	Data read/write cycle is used as break condition	

Bit 0—Break Interrupt Enable A (BIEA): Enables or disables channel A PC break interrupts.

Bit 0		
BIEA	Description	
0	PC break interrupts are disabled	(Initial value)
1	PC break interrupts are enabled	

6.2.4 Break Control Register B (BCRB)

BCRB is the channel B break control register. The bit configuration is the same as for BCRA.

6.2.5 Module Stop Control Register C (MSTPCRC)

Bit	7	6	5	4	3	2	1	0
	MSTPC7	MSTPC6	MSTPC5	MSTPC4	MSTPC3	MSTPC2	MSTPC1	MSTPC0
Initial value	1	1	1	1	1	1	1	1
Read/Write	R/W	R/W	R/W	R/W	R/W	R/W	R/W	R/W

MSTPCRC is an 8-bit readable/writable register that performs module stop mode control.

When the MSTPC4 bit is set to 1, PC break controller operation is stopped at the end of the bus cycle, and module stop mode is entered. Register read/write accesses are not possible in module stop mode. For details, see section 23A.5, 23B.5, Module Stop Mode.

MSTPCRC is initialized to H'FF by a reset and in hardware standby mode. It is not initialized in software standby mode.

Bit 4—Module Stop (MSTPC4): Specifies the PC break controller module stop mode.

Bit 4

MSTPC4	Description
0	PC break controller module stop mode is cleared
1	PC break controller module stop mode is set (Initial value)

6.3 Operation

The operation flow from break condition setting to PC break interrupt exception handling is shown in section 6.3.1, PC Break Interrupt Due to Instruction Fetch, and 6.3.2, PC Break Interrupt Due to Data Access, taking the example of channel A.

6.3.1 PC Break Interrupt Due to Instruction Fetch

(1) Initial settings

- Set the break address in BARA. For a PC break caused by an instruction fetch, set the address of the first instruction byte as the break address.
- Set the break conditions in BCRA.
 - BCRA bit 6 (CDA): With a PC break caused by an instruction fetch, the bus master must be the CPU. Set 0 to select the CPU.
 - BCRA bits 5 to 3 (BAMA2 to BAMA0): Set the address bits to be masked.
 - BCRA bits 2, 1 (CSELA1, CSELA0): Set 00 to specify an instruction fetch as the break condition.
 - BCRA bit 0 (BIEA): Set to 1 to enable break interrupts.

(2) Satisfaction of break condition

- When the instruction at the set address is fetched, a PC break request is generated immediately before execution of the fetched instruction, and the condition match flag (CMFA) is set.

(3) Interrupt handling

- After priority determination by the interrupt controller, PC break interrupt exception handling is started.

6.3.2 PC Break Interrupt Due to Data Access

(1) Initial settings

- Set the break address in BARA. For a PC break caused by a data access, set the target ROM, RAM, I/O, or external address space address as the break address. Stack operations and branch address reads are included in data accesses.
- Set the break conditions in BCRA.
 - BCRA bit 6 (CDA): Select the bus master.
 - BCRA bits 5 to 3 (BAMA2 to BAMA0): Set the address bits to be masked.
 - BCRA bits 2, 1 (CSELA1, CSELA0): Set 01, 10, or 11 to specify data access as the break condition.
 - BCRA bit 0 (BIEA): Set to 1 to enable break interrupts.

(2) Satisfaction of break condition

- After execution of the instruction that performs a data access on the set address, a PC break request is generated and the condition match flag (CMFA) is set.

(3) Interrupt handling

- After priority determination by the interrupt controller, PC break interrupt exception handling is started.

6.3.3 Notes on PC Break Interrupt Handling

- (1) The PC break interrupt is shared by channels A and B. The channel from which the request was issued must be determined by the interrupt handler.
- (2) The CMFA and CMFB flags are not cleared to 0, so 0 must be written to CMFA or CMFB after first reading the flag while it is set to 1. If the flag is left set to 1, another interrupt will be requested after interrupt handling ends.
- (3) A PC break interrupt generated when the DTC is the bus master is accepted after the bus has been transferred to the CPU by the bus controller.

6.3.4 Operation in Transitions to Power-Down Modes

The operation when a PC break interrupt is set for an instruction fetch at the address after a SLEEP instruction is shown below.

- (1) When the SLEEP instruction causes a transition from high-speed (medium-speed) mode to sleep mode, or from subactive mode* to subsleep mode*:
After execution of the SLEEP instruction, a transition is not made to sleep mode or subsleep mode*, and PC break interrupt handling is executed. After execution of PC break interrupt handling, the instruction at the address after the SLEEP instruction is executed (figure 6-2 (A)).
- (2) When the SLEEP instruction causes a transition from high-speed (medium-speed) mode to subactive mode*:
After execution of the SLEEP instruction, a transition is made to subactive mode* via direct transition exception handling. After the transition, PC break interrupt handling is executed, then the instruction at the address after the SLEEP instruction is executed (figure 6-2 (B)).
- (3) When the SLEEP instruction causes a transition from subactive mode* to high-speed (medium-speed) mode:
After execution of the SLEEP instruction, and following the clock oscillation settling time, a transition is made to high-speed (medium-speed) mode via direct transition exception handling. After the transition, PC break interrupt handling is executed, then the instruction at the address after the SLEEP instruction is executed (figure 6-2 (C)).
- (4) When the SLEEP instruction causes a transition to software standby mode or watch mode*:
After execution of the SLEEP instruction, a transition is made to the respective mode, and PC break interrupt handling is not executed. However, the CMFA or CMFB flag is set (figure 6-2 (D)).

Note: * Subclock functions (subactive mode, subsleep mode, and watch mode) are available in the U-mask and W-mask versions only.

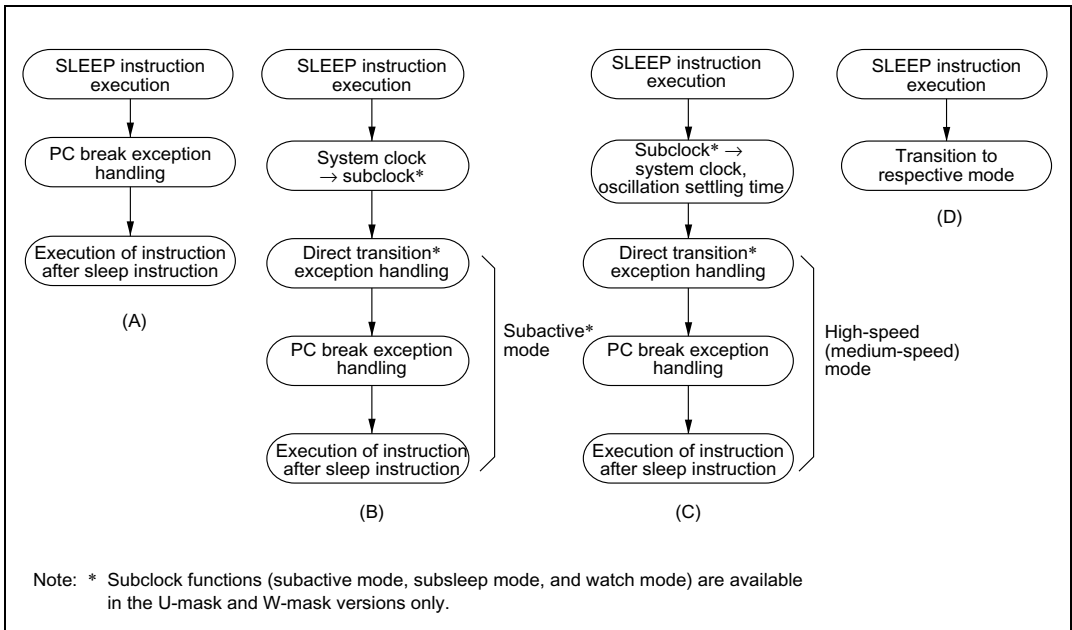

Figure 6-2 Operation in Power-Down Mode Transitions

6.3.5 PC Break Operation in Continuous Data Transfer

If a PC break interrupt is generated when the following operations are being performed, exception handling is executed on completion of the specified transfer.

- (1) When a PC break interrupt is generated at the transfer address of an EEPMOV.B instruction:
PC break exception handling is executed after all data transfers have been completed and the EEPMOV.B instruction has ended.
- (2) When a PC break interrupt is generated at a DTC transfer address:31
PC break exception handling is executed after the DTC has completed the specified number of data transfers, or after data for which the DISEL bit is set to 1 has been transferred.

6.3.6 When Instruction Execution Is Delayed by One State

Caution is required in the following cases, as instruction execution is one state later than usual.

- (1) When the PBC is enabled (i.e. when the break interrupt enable bit is set to 1), execution of a one-word branch instruction (Bcc d:8, BSR, JSR, JMP, TRAPA, RTE, or RTS) located in on-chip ROM or RAM is always delayed by one state.
- (2) When break interruption by instruction fetch is set, the set address indicates on-chip ROM or RAM space, and that address is used for data access, the instruction that executes the data access is one state later than in normal operation.
- (3) When break interruption by instruction fetch is set and a break interrupt is generated, if the executing instruction immediately preceding the set instruction has one of the addressing modes shown below, and that address indicates on-chip ROM or RAM, and that address is used for data access, the instruction will be one state later than in normal operation.

@ERn, @(d:16,ERn), @(d:32,ERn), @-ERn/ERn+, @aa:8, @aa:24, @aa:32, @(d:8,PC), @(d:16,PC), @@aa:8

- (4) When break interruption by instruction fetch is set and a break interrupt is generated, if the executing instruction immediately preceding the set instruction is NOP or SLEEP, or has #xx,Rn as its addressing mode, and that instruction is located in on-chip ROM or RAM, the instruction will be one state later than in normal operation.

6.3.7 Additional Notes

- (1) When a PC break is set for an instruction fetch at the address following a BSR, JSR, JMP, TRAPA, RTE, or RTS instruction:

Even if the instruction at the address following a BSR, JSR, JMP, TRAPA, RTE, or RTS instruction is fetched, it is not executed, and so a PC break interrupt is not generated by the instruction fetch at the next address.

- (2) When the I bit is set by an LDC, ANDC, ORC, or XORC instruction, a PC break interrupt becomes valid two states after the end of the executing instruction. If a PC break interrupt is set for the instruction following one of these instructions, since interrupts, including NMI, are disabled for a 3-state period in the case of LDC, ANDC, ORC, and XORC, the next instruction is always executed. For details, see section 5, Interrupt Controller.

- (3) When a PC break is set for an instruction fetch at the address following a Bcc instruction:

A PC break interrupt is generated if the instruction at the next address is executed in accordance with the branch condition, but is not generated if the instruction at the next address is not executed.

- (4) When a PC break is set for an instruction fetch at the branch destination address of a Bcc instruction:

A PC break interrupt is generated if the instruction at the branch destination is executed in accordance with the branch condition, but is not generated if the instruction at the branch destination is not executed.

Section 7 Bus Controller

7.1 Overview

The chip has an on-chip bus controller (BSC) that manages the external address space divided into eight areas. The bus specifications, such as bus width and number of access states, can be set independently for each area, enabling multiple memories to be connected easily.

The bus controller also has a bus arbitration function, and controls the operation of the internal bus masters: the CPU, and data transfer controller (DTC).

Note: The DTC is not implemented in the H8S/2635 Group.

7.1.1 Features

The features of the bus controller are listed below.

- Manages external address space in area units
 - Manages the external space as 8 areas of 2-Mbytes
 - Bus specifications can be set independently for each area
 - Burst ROM interface can be set
- Basic bus interface
 - 8-bit access or 16-bit access can be selected for each area
 - 2-state access or 3-state access can be selected for each area
 - Program wait states can be inserted for each area
- Burst ROM interface
 - Burst ROM interface can be set for area 0
 - Choice of 1- or 2-state burst access
- Idle cycle insertion
 - An idle cycle can be inserted in case of an external read cycle between different areas
 - An idle cycle can be inserted in case of an external write cycle immediately after an external read cycle
- Write buffer functions
 - External write cycle and internal access can be executed in parallel
- Bus arbitration function
 - Includes a bus arbiter that arbitrates bus mastership among the CPU and DTC

- Other features
 - External bus release function

7.1.2 Block Diagram

Figure 7-1 shows a block diagram of the bus controller.

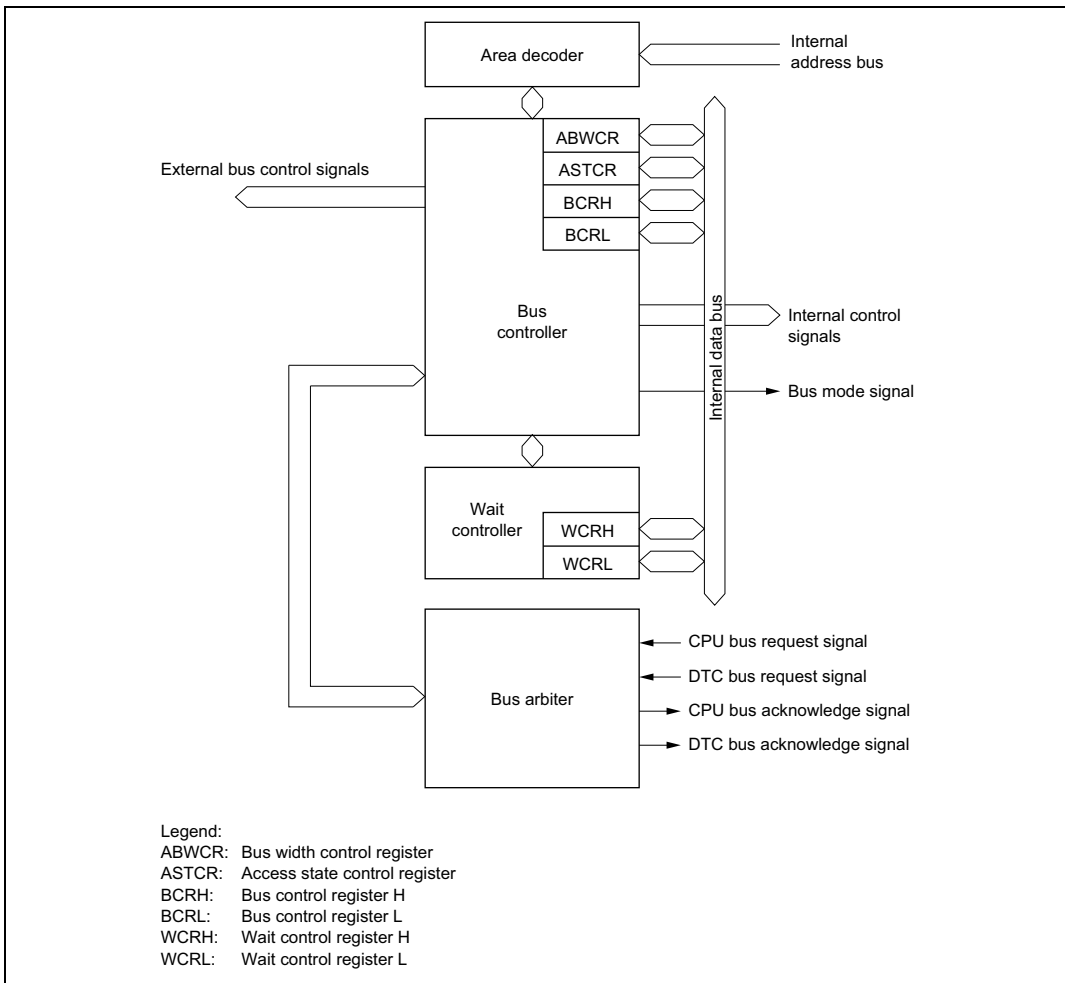

Figure 7-1 Block Diagram of Bus Controller

7.1.3 Pin Configuration

Table 7-1 summarizes the pins of the bus controller.

Table 7-1 Bus Controller Pins

Name	Symbol	I/O	Function
Address strobe	\overline{AS}	Output	Strobe signal indicating that address output on address bus is enabled.
Read	\overline{RD}	Output	Strobe signal indicating that external space is being read.
High write	\overline{HWR}	Output	Strobe signal indicating that external space is to be written, and upper half (D15 to D8) of data bus is enabled.
Low write	\overline{LWR}	Output	Strobe signal indicating that external space is to be written, and lower half (D7 to D0) of data bus is enabled.

7.1.4 Register Configuration

Table 7-2 summarizes the registers of the bus controller.

Table 7-2 Bus Controller Registers

Name	Abbreviation	R/W	Initial Value	Address* ¹
Bus width control register	ABWCR	R/W	H'FF/H'00* ²	H'FED0
Access state control register	ASTCR	R/W	H'FF	H'FED1
Wait control register H	WCRH	R/W	H'FF	H'FED2
Wait control register L	WCRL	R/W	H'FF	H'FED3
Bus control register H	BCRH	R/W	H'D0	H'FED4
Bus control register L	BCRL	R/W	H'08	H'FED5
Pin function control register	PFCR	R/W	H'0D/H'00	H'FDEB

- Notes: 1. Lower 16 bits of the address.
 2. Determined by the MCU operating mode.

7.2 Register Descriptions

7.2.1 Bus Width Control Register (ABWCR)

Bit	:	7	6	5	4	3	2	1	0
		ABW7	ABW6	ABW5	ABW4	ABW3	ABW2	ABW1	ABW0
Modes 5 to 7									
Initial value	:	1	1	1	1	1	1	1	1
RW	:	R/W	R/W	R/W	R/W	R/W	R/W	R/W	R/W
Mode 4									
Initial value	:	0	0	0	0	0	0	0	0
RW	:	R/W	R/W	R/W	R/W	R/W	R/W	R/W	R/W

ABWCR is an 8-bit readable/writable register that designates each area for either 8-bit access or 16-bit access.

ABWCR sets the data bus width for the external memory space. The bus width for on-chip memory and internal I/O registers is fixed regardless of the settings in ABWCR.

After a reset and in hardware standby mode, ABWCR is initialized to H'FF in modes 5, 6, 7, and to H'00 in mode 4. It is not initialized in software standby mode.

Bits 7 to 0—Area 7 to 0 Bus Width Control (ABW7 to ABW0): These bits select whether the corresponding area is to be designated for 8-bit access or 16-bit access.

Bit n

ABWn	Description
0	Area n is designated for 16-bit access
1	Area n is designated for 8-bit access

(n = 7 to 0)

7.2.2 Access State Control Register (ASTCR)

Bit	:	7	6	5	4	3	2	1	0
		AST7	AST6	AST5	AST4	AST3	AST2	AST1	AST0
Initial value	:	1	1	1	1	1	1	1	1
R/W	:	R/W	R/W	R/W	R/W	R/W	R/W	R/W	R/W

ASTCR is an 8-bit readable/writable register that designates each area as either a 2-state access space or a 3-state access space.

ASTCR sets the number of access states for the external memory space. The number of access states for on-chip memory and internal I/O registers is fixed regardless of the settings in ASTCR.

ASTCR is initialized to H'FF by a reset and in hardware standby mode. It is not initialized in software standby mode.

Bits 7 to 0—Area 7 to 0 Access State Control (AST7 to AST0): These bits select whether the corresponding area is to be designated as a 2-state access space or a 3-state access space.

Wait state insertion is enabled or disabled at the same time.

Bit n

ASTn	Description
0	Area n is designated for 2-state access Wait state insertion in area n external space is disabled
1	Area n is designated for 3-state access Wait state insertion in area n external space is enabled

(Initial value)
(n = 7 to 0)

7.2.3 Wait Control Registers H and L (WCRH, WCRL)

WCRH and WCRL are 8-bit readable/writable registers that select the number of program wait states for each area.

Program waits are not inserted in the case of on-chip memory or internal I/O registers.

WCRH and WCRL are initialized to H'FF by a reset and in hardware standby mode. They are not initialized in software standby mode.

WCRH

Bit	:	7	6	5	4	3	2	1	0								
		<table border="1"> <tr> <td>W71</td> <td>W70</td> <td>W61</td> <td>W60</td> <td>W51</td> <td>W50</td> <td>W41</td> <td>W40</td> </tr> </table>								W71	W70	W61	W60	W51	W50	W41	W40
W71	W70	W61	W60	W51	W50	W41	W40										
Initial value	:	1	1	1	1	1	1	1	1								
R/W	:	R/W	R/W	R/W	R/W	R/W	R/W	R/W	R/W								

Bits 7 and 6—Area 7 Wait Control 1 and 0 (W71, W70): These bits select the number of program wait states when area 7 in external space is accessed while the AST7 bit in ASTCR is set to 1.

Bit 7	Bit 6	Description
W71	W70	
0	0	Program wait not inserted when external space area 7 is accessed
	1	1 program wait state inserted when external space area 7 is accessed
1	0	2 program wait states inserted when external space area 7 is accessed
	1	3 program wait states inserted when external space area 7 is accessed (Initial value)

Bits 5 and 4—Area 6 Wait Control 1 and 0 (W61, W60): These bits select the number of program wait states when area 6 in external space is accessed while the AST6 bit in ASTCR is set to 1.

Bit 5	Bit 4	
W61	W60	Description
0	0	Program wait not inserted when external space area 6 is accessed
	1	1 program wait state inserted when external space area 6 is accessed
1	0	2 program wait states inserted when external space area 6 is accessed
	1	3 program wait states inserted when external space area 6 is accessed (Initial value)

Bits 3 and 2—Area 5 Wait Control 1 and 0 (W51, W50): These bits select the number of program wait states when area 5 in external space is accessed while the AST5 bit in ASTCR is set to 1.

Bit 3	Bit 2	
W51	W50	Description
0	0	Program wait not inserted when external space area 5 is accessed
	1	1 program wait state inserted when external space area 5 is accessed
1	0	2 program wait states inserted when external space area 5 is accessed
	1	3 program wait states inserted when external space area 5 is accessed (Initial value)

Bits 1 and 0—Area 4 Wait Control 1 and 0 (W41, W40): These bits select the number of program wait states when area 4 in external space is accessed while the AST4 bit in ASTCR is set to 1.

Bit 1	Bit 0	
W41	W40	Description
0	0	Program wait not inserted when external space area 4 is accessed
	1	1 program wait state inserted when external space area 4 is accessed
1	0	2 program wait states inserted when external space area 4 is accessed
	1	3 program wait states inserted when external space area 4 is accessed (Initial value)

WCRL

Bit	:	7	6	5	4	3	2	1	0
		W31	W30	W21	W20	W11	W10	W01	W00
Initial value	:	1	1	1	1	1	1	1	1
R/W	:	R/W	R/W	R/W	R/W	R/W	R/W	R/W	R/W

Bits 7 and 6—Area 3 Wait Control 1 and 0 (W31, W30): These bits select the number of program wait states when area 3 in external space is accessed while the AST3 bit in ASTCR is set to 1.

Bit 7	Bit 6	
W31	W30	Description
0	0	Program wait not inserted when external space area 3 is accessed
	1	1 program wait state inserted when external space area 3 is accessed
1	0	2 program wait states inserted when external space area 3 is accessed
	1	3 program wait states inserted when external space area 3 is accessed (Initial value)

Bits 5 and 4—Area 2 Wait Control 1 and 0 (W21, W20): These bits select the number of program wait states when area 2 in external space is accessed while the AST2 bit in ASTCR is set to 1.

Bit 5	Bit 4	
W21	W20	Description
0	0	Program wait not inserted when external space area 2 is accessed
	1	1 program wait state inserted when external space area 2 is accessed
1	0	2 program wait states inserted when external space area 2 is accessed
	1	3 program wait states inserted when external space area 2 is accessed (Initial value)

Bits 3 and 2—Area 1 Wait Control 1 and 0 (W11, W10): These bits select the number of program wait states when area 1 in external space is accessed while the AST1 bit in ASTCR is set to 1.

Bit 3	Bit 2	
W11	W10	Description
0	0	Program wait not inserted when external space area 1 is accessed
	1	1 program wait state inserted when external space area 1 is accessed
1	0	2 program wait states inserted when external space area 1 is accessed
	1	3 program wait states inserted when external space area 1 is accessed (Initial value)

Bits 1 and 0—Area 0 Wait Control 1 and 0 (W01, W00): These bits select the number of program wait states when area 0 in external space is accessed while the AST0 bit in ASTCR is set to 1.

Bit 1	Bit 0	
W01	W00	Description
0	0	Program wait not inserted when external space area 0 is accessed
	1	1 program wait state inserted when external space area 0 is accessed
1	0	2 program wait states inserted when external space area 0 is accessed
	1	3 program wait states inserted when external space area 0 is accessed (Initial value)

7.2.4 Bus Control Register H (BCRH)

Bit	:	7	6	5	4	3	2	1	0
		ICIS1	ICIS0	BRSTRM	BRSTS1	BRSTS0	—	—	—
Initial value	:	1	1	0	1	0	0	0	0
R/W	:	R/W	R/W	R/W	R/W	R/W	R/W	R/W	R/W

BCRH is an 8-bit readable/writable register that selects enabling or disabling of idle cycle insertion, and the memory interface for area 2 to 5, and 0.

BCRH is initialized to H'D0 by a reset and in hardware standby mode. It is not initialized in software standby mode.

Bit 7—Idle Cycle Insert 1 (ICIS1): Selects whether or not one idle cycle state is to be inserted between bus cycles when successive external read cycles are performed in different areas.

Bit 7

ICIS1	Description
0	Idle cycle not inserted in case of successive external read cycles in different areas
1	Idle cycle inserted in case of successive external read cycles in different areas (Initial value)

Bit 6—Idle Cycle Insert 0 (ICIS0): Selects whether or not one idle cycle state is to be inserted between bus cycles when successive external read and external write cycles are performed .

Bit 6

ICIS0	Description
0	Idle cycle not inserted in case of successive external read and external write cycles
1	Idle cycle inserted in case of successive external read and external write cycles (Initial value)

Bit 5—Burst ROM Enable (BRSTRM): Selects whether area 0 is used as a burst ROM interface.

Bit 5

BRSTRM	Description	
0	Area 0 is basic bus interface	(Initial value)
1	Area 0 is burst ROM interface	

Bit 4—Burst Cycle Select 1 (BRSTS1): Selects the number of burst cycles for the burst ROM interface.

Bit 4

BRSTS1	Description	
0	Burst cycle comprises 1 state	
1	Burst cycle comprises 2 states	(Initial value)

Bit 3—Burst Cycle Select 0 (BRSTS0): Selects the number of words that can be accessed in a burst ROM interface burst access.

Bit 3

BRSTS0	Description	
0	Max. 4 words in burst access	(Initial value)
1	Max. 8 words in burst access	

Bits 2 to 0—Reserved: Only 0 should be written to these bits.

7.2.5 Bus Control Register L (BCRL)

Bit	:	7	6	5	4	3	2	1	0
		—	—	—	—	—	—	WDBE	—
Initial value	:	0	0	0	0	1	0	0	0
R/W	:	R/W	R/W	—	R/W	R/W	R/W	R/W	R/W

BCRL is an 8-bit readable/writable register that performs selection of the external bus-released state protocol, enabling or disabling of the write data buffer function.

BCRL is initialized to H'08 by a reset and in hardware standby mode. It is not initialized in software standby mode.

Bits 7 and 6—Reserved: Only 0 should be written to these bits.

Bit 5—Reserved: It is always read as 0. Cannot be written to.

Bit 4—Reserved: Only 0 should be written to this bit.

Bit 3—Reserved: Only 1 should be written to this bit.

Bit 2—Reserved: Only 0 should be written to this bit.

Bit 1—Write Data Buffer Enable (WDBE): This bit selects whether or not to use the write buffer function in the external write cycle.

Bit 1

WDBE	Description
0	Write data buffer function not used (Initial value)
1	Write data buffer function used

Bit 0—Reserved: Only 0 should be written to these bits.

7.2.6 Pin Function Control Register (PFCR)

Bit	:	7	6	5	4	3	2	1	0
		—	—	—	—	AE3	AE2	AE1	AE0
Initial value	:	0	0	0	0	1/0	1/0	0	1/0
R/W	:	R/W	R/W	R/W	R/W	R/W	R/W	R/W	R/W

PFCR is an 8-bit read/write register that controls the address output in on-chip ROM-enabled expansion mode.

PFCR is initialized to H'0D/H'00 by a reset and in hardware standby mode. It retains its previous state in software standby mode.

Bits 7 to 4—Reserved: Only 0 should be written to these bits.

Bits 3 to 0—Address Output Enable 3 to 0 (AE3 to AE0): These bits select enabling or disabling of address outputs A8 to A23 in on-chip ROM-disabled expansion mode and on-chip ROM-enabled expansion mode. When a pin is enabled for address output, the address is output regardless of the corresponding DDR setting. When a pin is disabled for address output, it becomes an output port when the corresponding DDR bit is set to 1.

Bit 3	Bit 2	Bit 1	Bit 0	Description
AE3	AE2	AE1	AE0	
0	0	0	0	A8 to A23 address output disabled (Initial value [*])
			1	A8 address output enabled; A9 to A23 address output disabled
		1	0	A8, A9 address output enabled; A10 to A23 address output disabled
			1	A8 to A10 address output enabled; A11 to A23 address output disabled
	1	0	0	A8 to A11 address output enabled; A12 to A23 address output disabled
			1	A8 to A12 address output enabled; A13 to A23 address output disabled
		1	0	A8 to A13 address output enabled; A14 to A23 address output disabled
			1	A8 to A14 address output enabled; A15 to A23 address output disabled
1	0	0	0	A8 to A15 address output enabled; A16 to A23 address output disabled
			1	A8 to A16 address output enabled; A17 to A23 address output disabled
		1	0	A8 to A17 address output enabled; A18 to A23 address output disabled
			1	A8 to A18 address output enabled; A19 to A23 address output disabled
	1	0	0	A8 to A19 address output enabled; A20 to A23 address output disabled
			1	A8 to A20 address output enabled; A21 to A23 address output disabled (Initial value [*])
		1	0	A8 to A21 address output enabled; A22, A23 address output disabled
			1	A8 to A23 address output enabled

Note: * In on-chip ROM-enabled expansion mode, bits AE3 to AE0 are initialized to B'0000.

In on-chip ROM-disabled expansion mode, bits AE3 to AE0 are initialized to B'1101.

Address pins A0 to A7 are made address outputs by setting the corresponding DDR bits to 1.

7.3.2 Bus Specifications

The external space bus specifications consist of three elements: bus width, number of access states, and number of program wait states.

The bus width and number of access states for on-chip memory and internal I/O registers are fixed, and are not affected by the bus controller.

Bus Width: A bus width of 8 or 16 bits can be selected with ADWCR. An area for which an 8-bit bus is selected functions as an 8-bit access space, and an area for which a 16-bit bus is selected functions as a 16-bit access space.

If all areas are designated for 8-bit access, 8-bit bus mode is set; if any area is designated for 16-bit access, 16-bit bus mode is set. When the burst ROM interface is designated, 16-bit bus mode is always set.

Number of Access States: Two or three access states can be selected with ASTCR. An area for which 2-state access is selected functions as a 2-state access space, and an area for which 3-state access is selected functions as a 3-state access space.

With the burst ROM interface, the number of access states may be determined without regard to ASTCR.

When 2-state access space is designated, wait insertion is disabled.

Number of Program Wait States: When 3-state access space is designated by ASTCR, the number of program wait states to be inserted automatically is selected with WCRH and WCRL. From 0 to 3 program wait states can be selected.

Table 7-3 shows the bus specifications for each basic bus interface area.

Table 7-3 Bus Specifications for Each Area (Basic Bus Interface)

ABWCR	ASTCR	WCRH, WCRL		Bus Specifications (Basic Bus Interface)		
ABWn	ASTn	Wn1	Wn0	Bus Width	Access States	Program Wait States
0	0	—	—	16	2	0
	1	0	0		3	0
			1		1	
			0		2	
			1		3	
1	0	—	—	8	2	0
	1	0	0		3	0
			1		1	
			0		2	
			1		3	

7.3.3 Memory Interfaces

The chip's memory interfaces comprise a basic bus interface that allows direct connection or ROM, SRAM, and so on, and a burst ROM interface that allows direct connection of burst ROM. The memory interface can be selected independently for each area.

An area for which the basic bus interface is designated functions as normal space, and an area for which the burst ROM interface is designated functions as burst ROM space.

7.3.4 Interface Specifications for Each Area

The initial state of each area is basic bus interface, 3-state access space. The initial bus width is selected according to the operating mode. The bus specifications described here cover basic items only, and the sections on each memory interface (7.4, Basic Bus Interface, and 7.5, Burst ROM Interface) should be referred to for further details.

Area 0: Area 0 includes on-chip ROM, and in ROM-disabled expansion mode, all of area 0 is external space. In ROM-enabled expansion mode, the space excluding on-chip ROM is external space.

Either basic bus interface or burst ROM interface can be selected for area 0.

Areas 1 to 6: In external expansion mode, all of areas 1 to 6 is external space.

Only the basic bus interface can be used for areas 1 to 6.

Area 7: Area 7 includes the on-chip RAM and internal I/O registers. In external expansion mode, the space excluding the on-chip RAM and internal I/O registers is external space. The on-chip RAM is enabled when the RAME bit in the system control register (SYSCR) is set to 1; when the RAME bit is cleared to 0, the on-chip RAM is disabled and the corresponding space becomes external space.

Only the basic bus interface can be used for the area 7.

7.4 Basic Bus Interface

7.4.1 Overview

The basic bus interface enables direct connection of ROM, SRAM, and so on.

The bus specifications can be selected with ABWCR, ASTCR, WCRH, and WCRL (see table 7-3).

7.4.2 Data Size and Data Alignment

Data sizes for the CPU and other internal bus masters are byte, word, and longword. The bus controller has a data alignment function, and when accessing external space, controls whether the upper data bus (D15 to D8) or lower data bus (D7 to D0) is used according to the bus specifications for the area being accessed (8-bit access space or 16-bit access space) and the data size.

8-Bit Access Space: Figure 7-3 illustrates data alignment control for the 8-bit access space. With the 8-bit access space, the upper data bus (D15 to D8) is always used for accesses. The amount of data that can be accessed at one time is one byte: a word transfer instruction is performed as two byte accesses, and a longword transfer instruction, as four byte accesses.

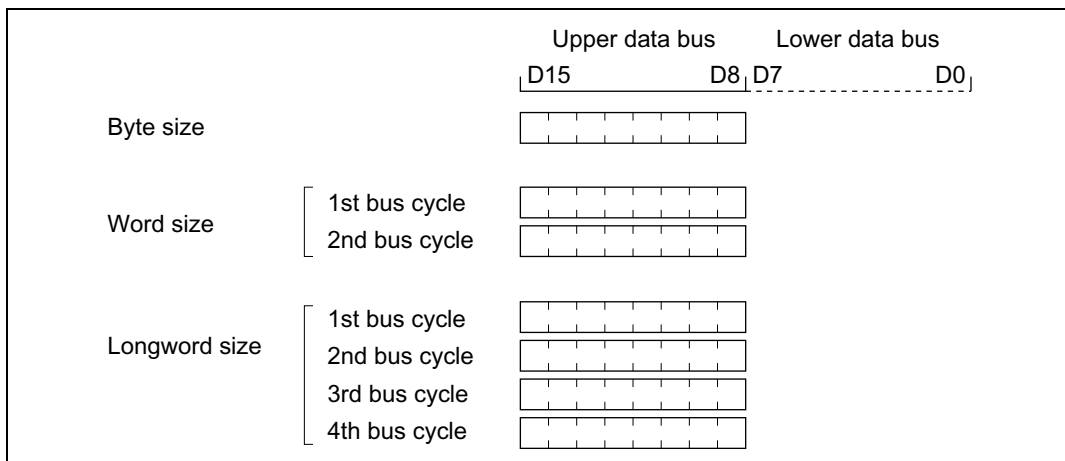

Figure 7-3 Access Sizes and Data Alignment Control (8-Bit Access Space)

16-Bit Access Space: Figure 7-4 illustrates data alignment control for the 16-bit access space. With the 16-bit access space, the upper data bus (D15 to D8) and lower data bus (D7 to D0) are used for accesses. The amount of data that can be accessed at one time is one byte or one word, and a longword transfer instruction is executed as two word transfer instructions.

In byte access, whether the upper or lower data bus is used is determined by whether the address is even or odd. The upper data bus is used for an even address, and the lower data bus for an odd address.

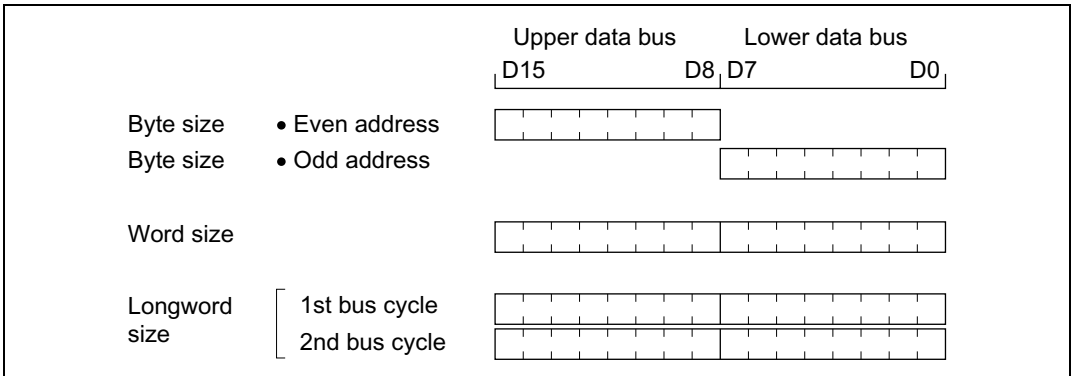

Figure 7-4 Access Sizes and Data Alignment Control (16-Bit Access Space)

7.4.3 Valid Strobes

Table 7-4 shows the data buses used and valid strobes for the access spaces.

In a read, the \overline{RD} signal is valid without discrimination between the upper and lower halves of the data bus.

In a write, the \overline{HWR} signal is valid for the upper half of the data bus, and the \overline{LWR} signal for the lower half.

Table 7-4 Data Buses Used and Valid Strobes

Area	Access Size	Read/Write	Address	Valid Strobe	Upper Data Bus (D15 to D8)	Lower data bus (D7 to D0)
8-bit access space	Byte	Read	—	\overline{RD}	Valid	Invalid
		Write	—	\overline{HWR}		Hi-Z
16-bit access space	Byte	Read	Even	\overline{RD}	Valid	Invalid
			Odd		Invalid	Valid
		Write	Even	\overline{HWR}	Valid	Hi-Z
			Odd	\overline{LWR}	Hi-Z	Valid
Word	Read	—	\overline{RD}	Valid	Valid	
	Write	—		$\overline{HWR}, \overline{LWR}$	Valid	Valid

Note: Hi-Z: High impedance.

Invalid: Input state; input value is ignored.

7.4.4 Basic Timing

8-Bit 2-State Access Space: Figure 7-5 shows the bus timing for an 8-bit 2-state access space. When an 8-bit access space is accessed, the upper half (D15 to D8) of the data bus is used.

The $\overline{\text{LWR}}$ pin is fixed high. Wait states cannot be inserted.

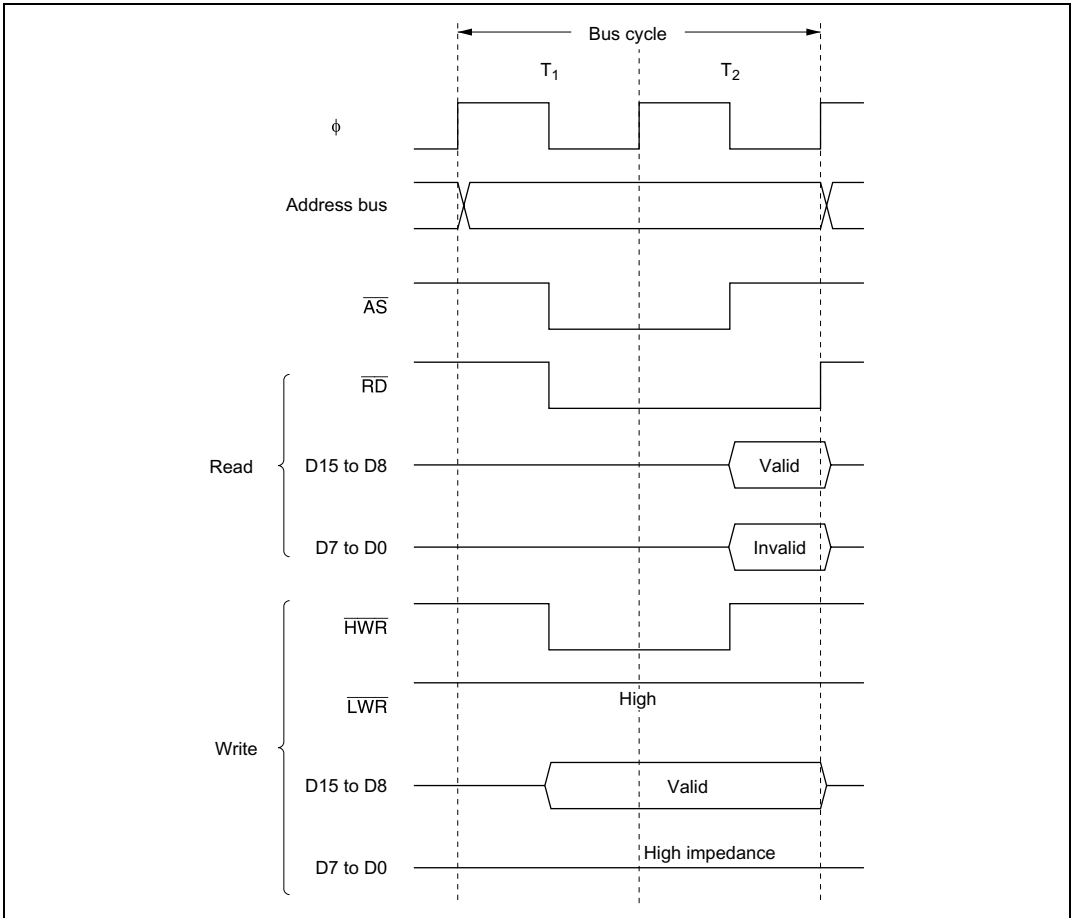

Figure 7-5 Bus Timing for 8-Bit 2-State Access Space

8-Bit 3-State Access Space: Figure 7-6 shows the bus timing for an 8-bit 3-state access space. When an 8-bit access space is accessed, the upper half (D15 to D8) of the data bus is used.

The $\overline{\text{LWR}}$ pin is fixed high. Wait states can be inserted.

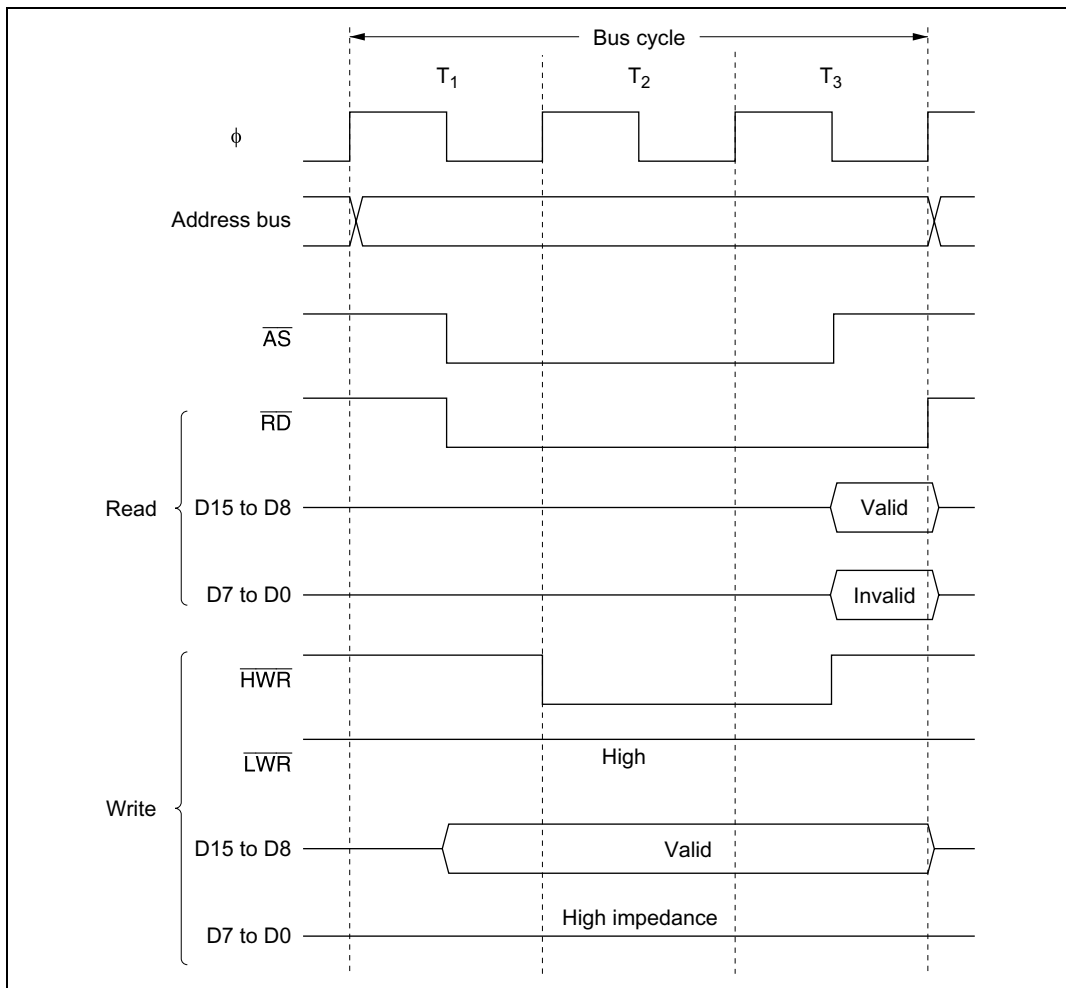

Figure 7-6 Bus Timing for 8-Bit 3-State Access Space

16-Bit 2-State Access Space: Figures 7-7 to 7-9 show bus timings for a 16-bit 2-state access space. When a 16-bit access space is accessed, the upper half (D15 to D8) of the data bus is used for the even address, and the lower half (D7 to D0) for the odd address.

Wait states cannot be inserted.

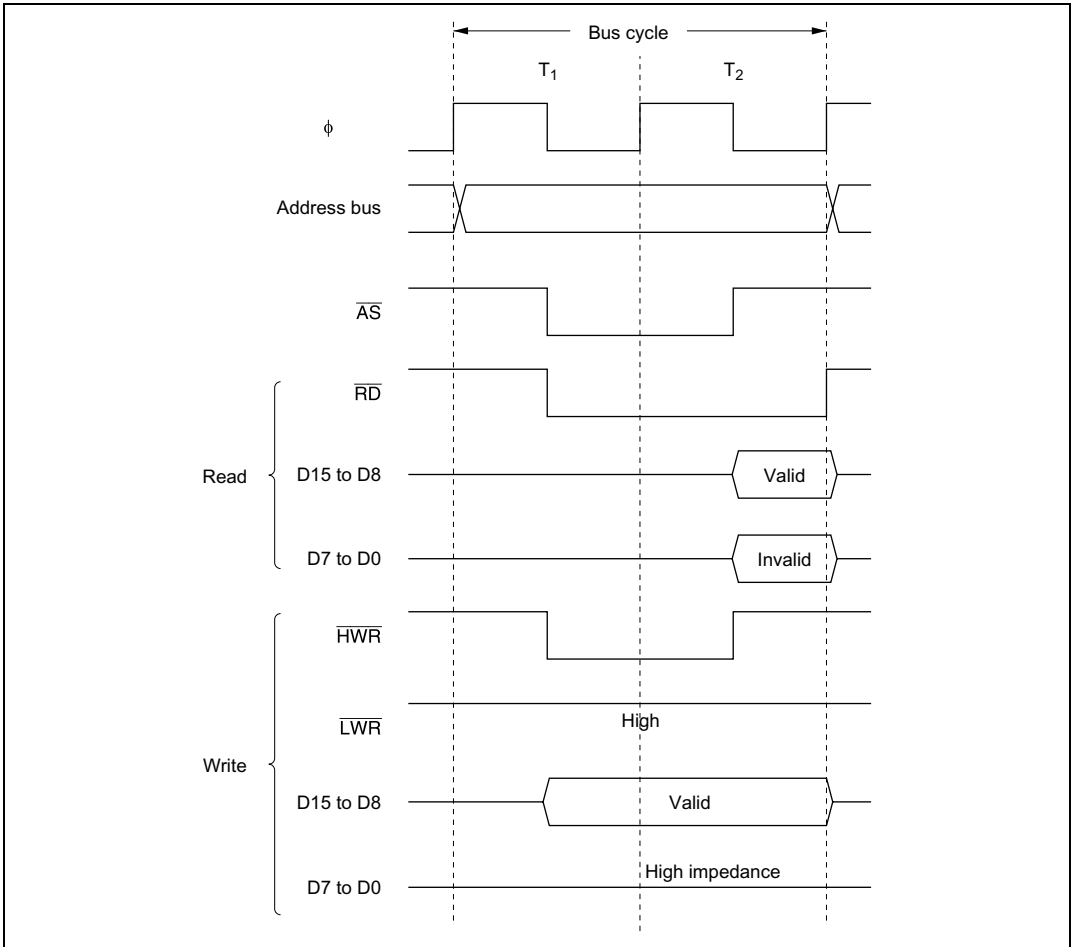

Figure 7-7 Bus Timing for 16-Bit 2-State Access Space (1) (Even Address Byte Access)

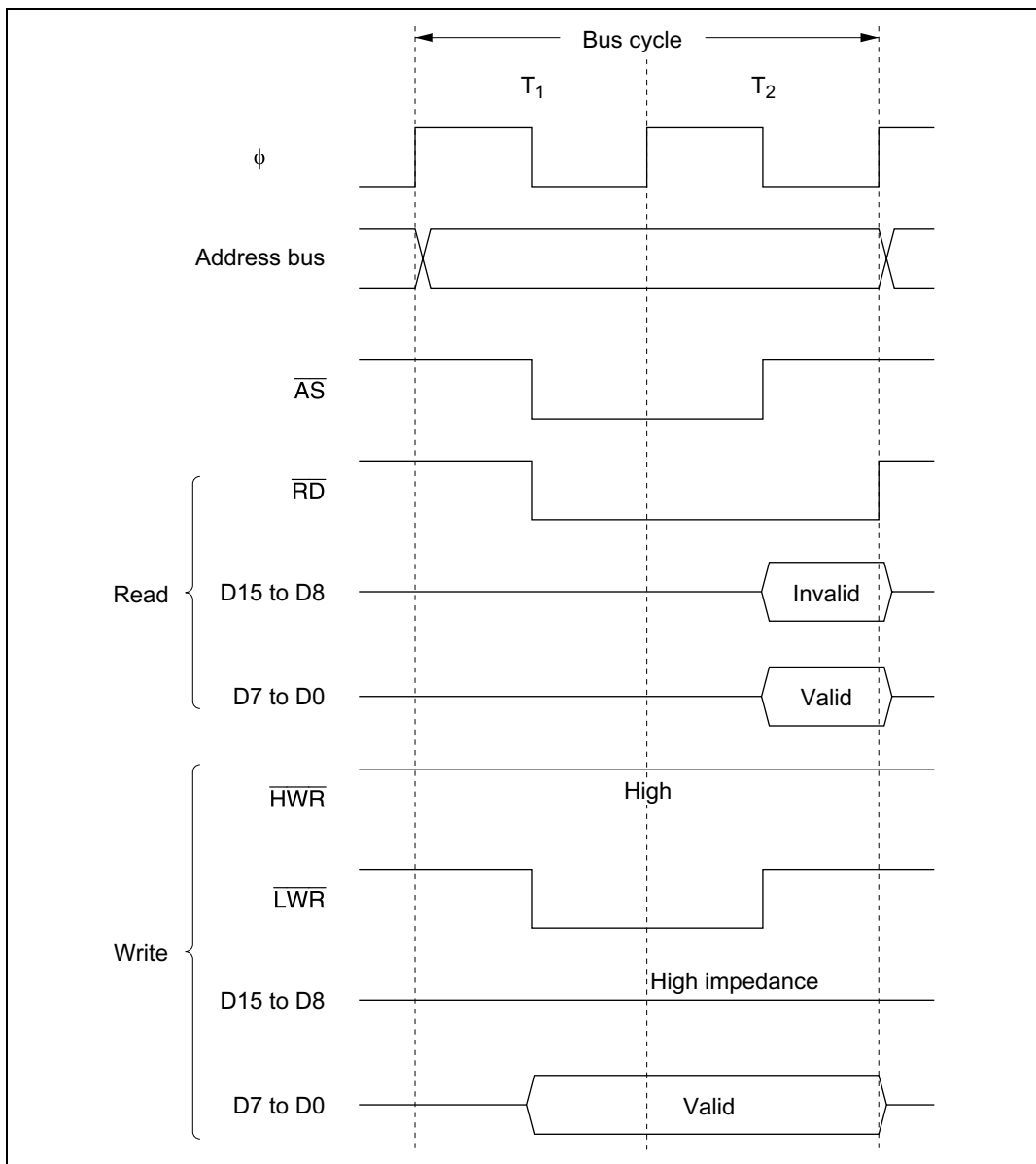

Figure 7-8 Bus Timing for 16-Bit 2-State Access Space (2) (Odd Address Byte Access)

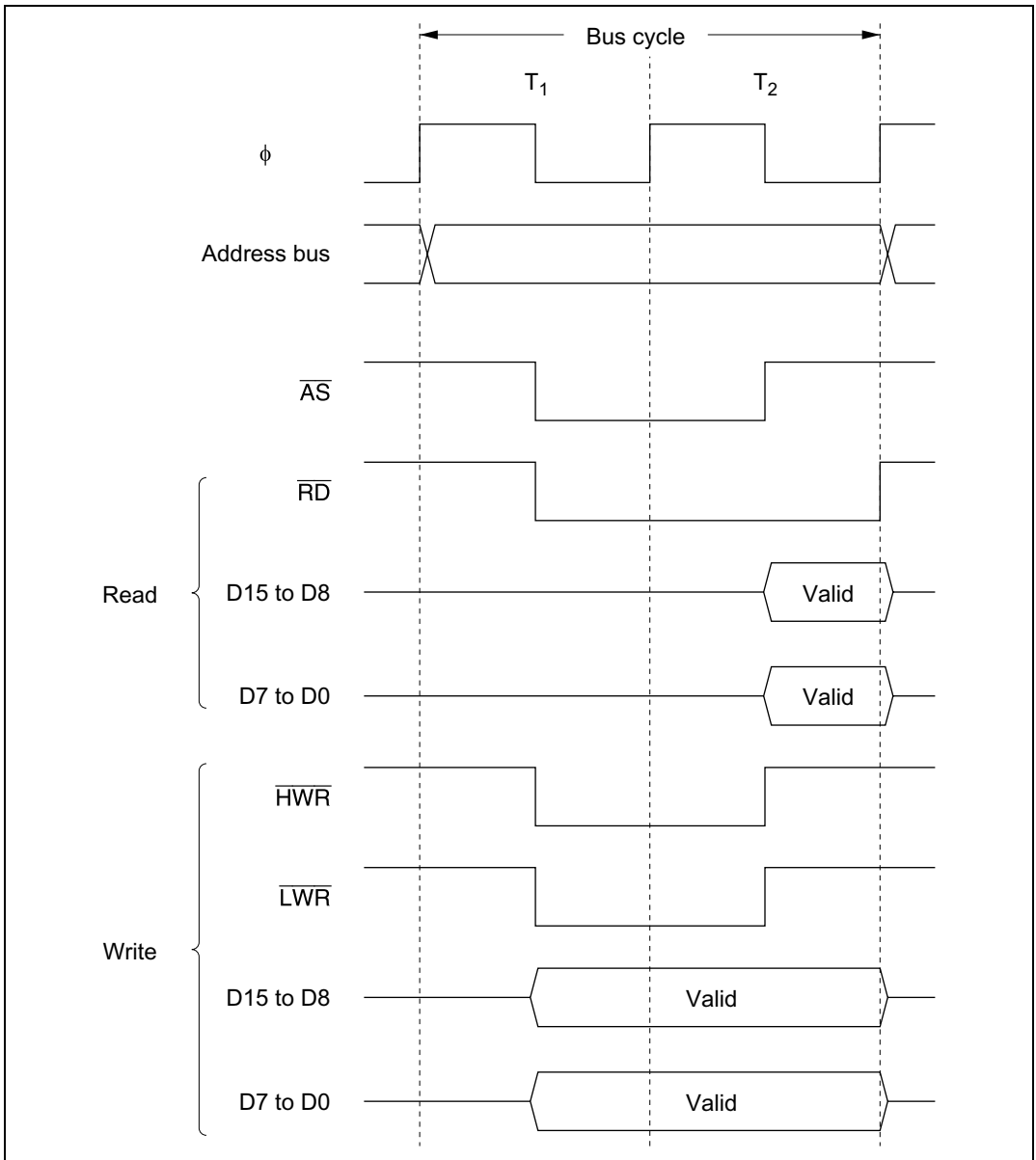

Figure 7-9 Bus Timing for 16-Bit 2-State Access Space (3) (Word Access)

16-Bit 3-State Access Space: Figures 7-10 to 7-12 show bus timings for a 16-bit 3-state access space. When a 16-bit access space is accessed, the upper half (D15 to D8) of the data bus is used for the even address, and the lower half (D7 to D0) for the odd address.

Wait states can be inserted.

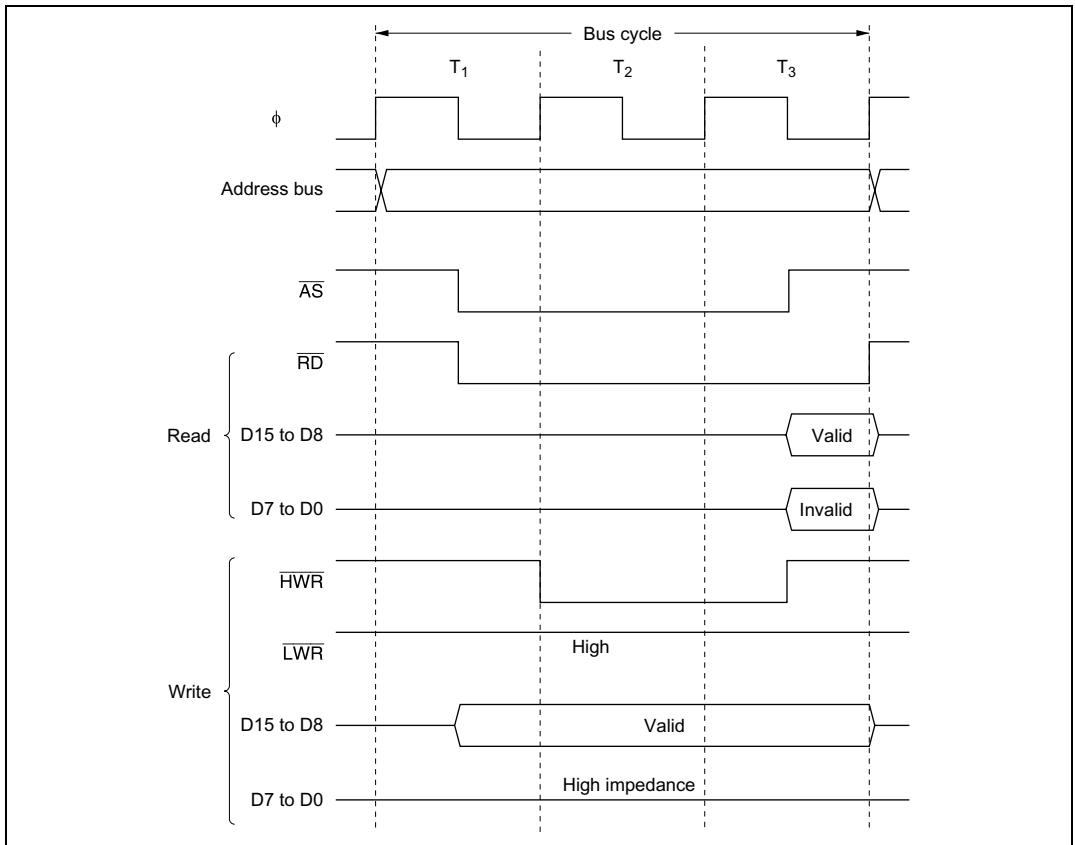

Figure 7-10 Bus Timing for 16-Bit 3-State Access Space (1) (Even Address Byte Access)

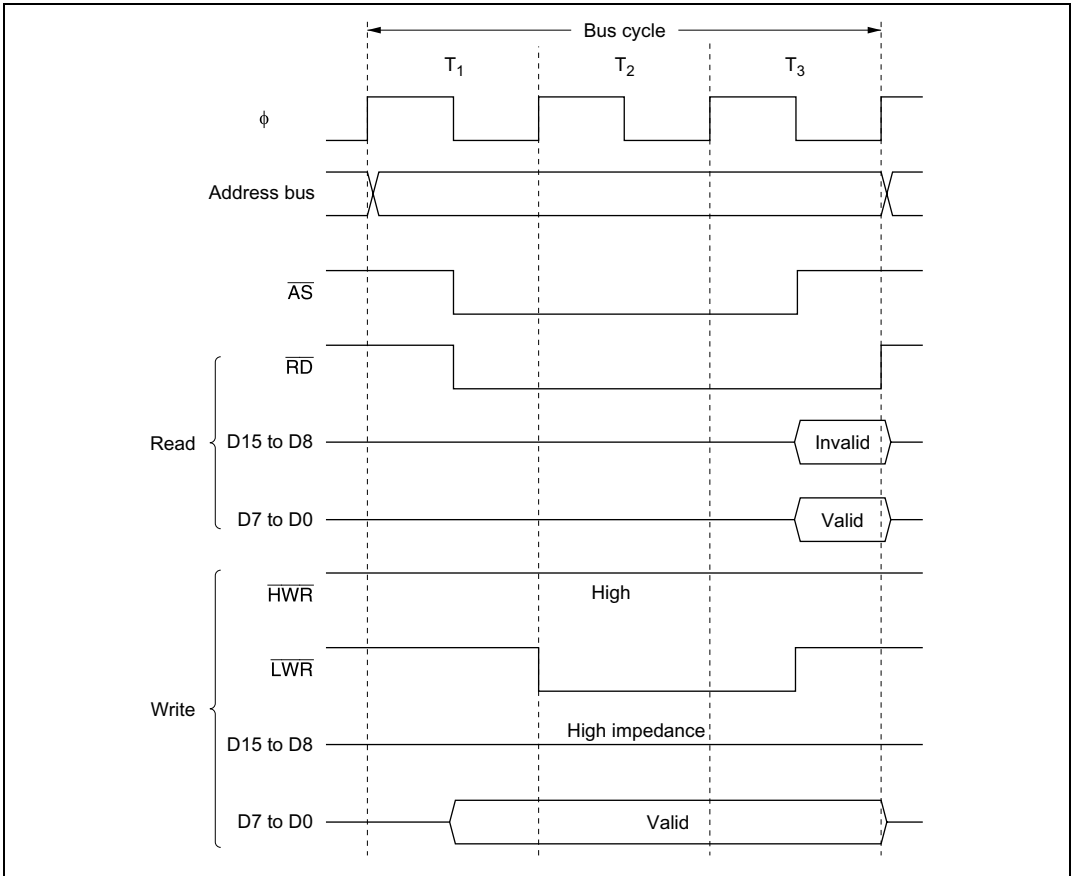

Figure 7-11 Bus Timing for 16-Bit 3-State Access Space (2) (Odd Address Byte Access)

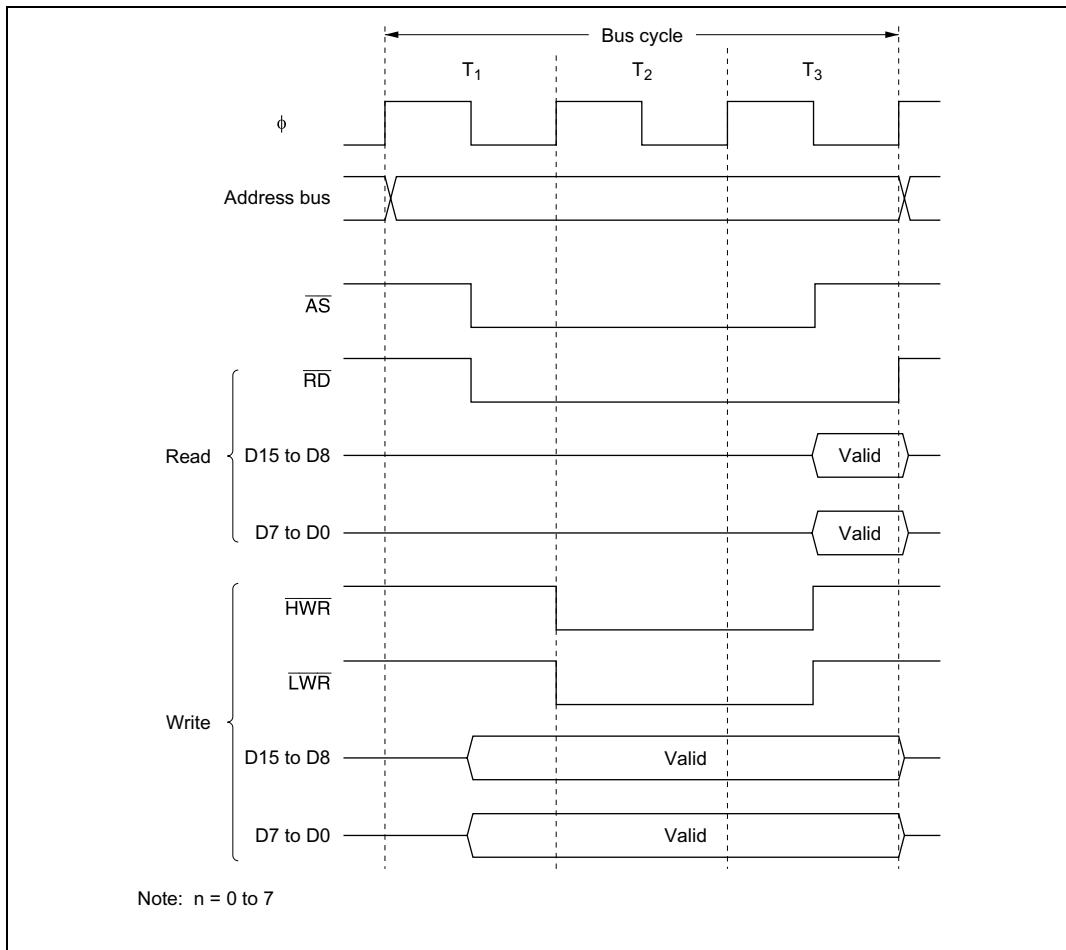

Figure 7-12 Bus Timing for 16-Bit 3-State Access Space (3) (Word Access)

7.4.5 Wait Control

When accessing external space, the chip can extend the bus cycle by inserting one or more wait states (T_w). There are two ways of inserting wait states: program wait insertion.

Program Wait Insertion

From 0 to 3 wait states can be inserted automatically between the T_2 state and T_3 state on an individual area basis in 3-state access space, according to the settings of WCRH and WCRL.

Figure 7-13 shows an example of wait state insertion timing.

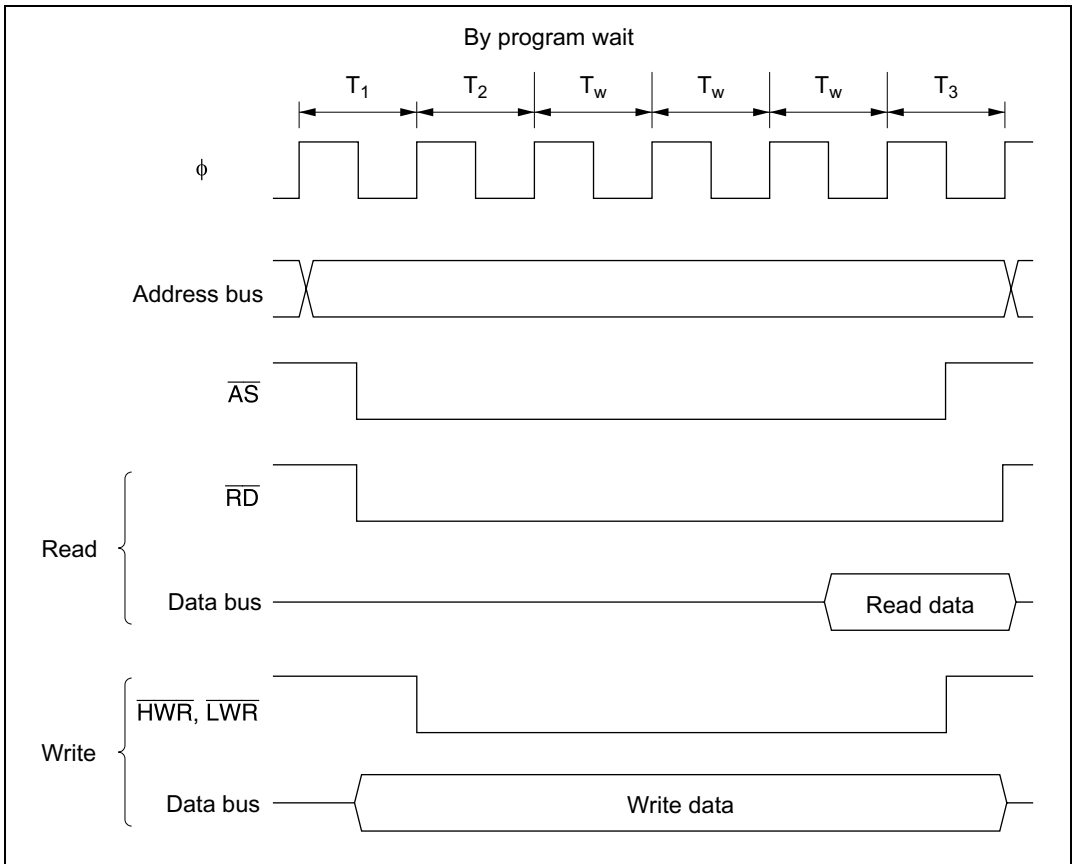

Figure 7-13 Example of Wait State Insertion Timing

The settings after a reset are: 3-state access, 3 program wait state insertion.

7.5 Burst ROM Interface

7.5.1 Overview

In this LSI, the area 0 external space can be set as burst ROM space and burst ROM interfacing performed. Burst ROM space interfacing allows 16-bit ROM capable of burst access to be accessed at high-speed.

The BRSTRM bit of BCRH sets area 0 as burst ROM space. CPU instruction fetches (only) can be performed using a maximum of 4-word or 8-word continuous burst access. 1 state or 2 states can be selected in the case of burst access.

7.5.2 Basic Timing

The AST0 bit of ASTCR sets the number of access states in the initial cycle (full access) of the burst ROM interface. Wait states can be inserted when the AST0 bit is set to 1. The burst cycle can be set for 1 state or 2 states by setting the BRSTS1 bit of BCRH. Wait states cannot be inserted. When area 0 is set as burst ROM space, area 0 is a 16-bit access space regardless of the ABW0 bit of ABWCR.

When the BRSTS0 bit of BCRH is cleared to 0, 4-word max. burst access is performed. When the BRSTS0 bit is set to 1, 8-word max. burst access is performed.

Figures 7-14 (a) and (b) show the basic access timing for the burst ROM space.

Figure 7-14 (a) is an example when both the AST0 and BRSTS1 bits are set to 1.

Figure 7-14 (b) is an example when both the AST0 and BRSTS1 bits are set to 0.

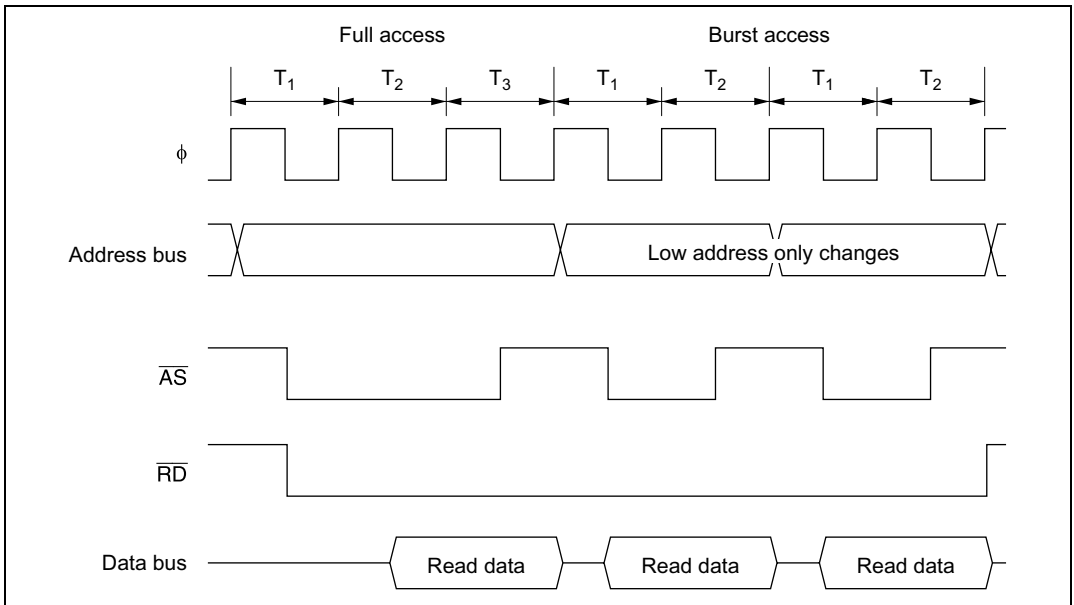

Figure 7-14 (a) Example Burst ROM Access Timing (AST0 = BRSTS1 = 1)

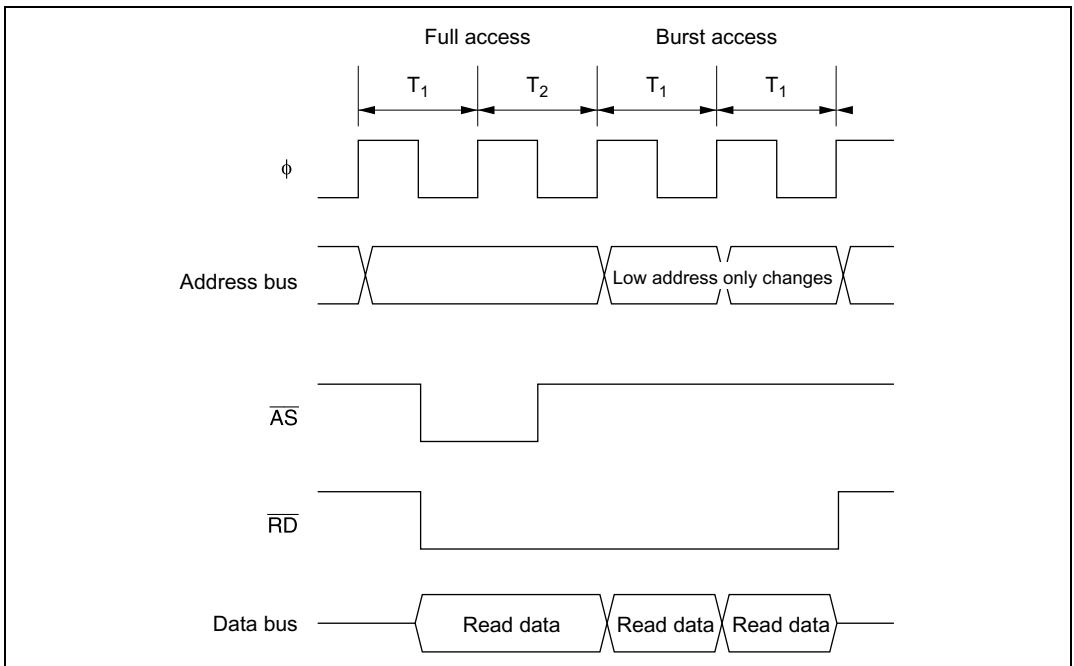

Figure 7-14 (b) Example Burst ROM Access Timing (AST0 = BRSTS1 = 0)

7.5.3 Wait Control

As with the basic bus interface, program waits can be inserted in the burst ROM interface initial cycle (full access). See section 7.4.5, Wait Control.

Wait states cannot be inserted in the burst cycle.

7.6 Idle Cycle

7.6.1 Operation

When the chip accesses external space, it can insert a 1-state idle cycle (T_1) between bus cycles in the following two cases: (1) when read accesses between different areas occur consecutively, and (2) when a write cycle occurs immediately after a read cycle. By inserting an idle cycle it is possible, for example, to avoid data collisions between ROM, with a long output floating time, and high-speed memory, I/O interfaces, and so on.

(1) Consecutive Reads between Different Areas

If consecutive reads between different areas occur while the ICIS1 bit in BCRH is set to 1, an idle cycle is inserted at the start of the second read cycle.

Figure 7-15 shows an example of the operation in this case. In this example, bus cycle A is a read cycle from ROM with a long output floating time, and bus cycle B is a read cycle from SRAM, each being located in a different area. In (a), an idle cycle is not inserted, and a collision occurs in cycle B between the read data from ROM and that from SRAM. In (b), an idle cycle is inserted, and a data collision is prevented.

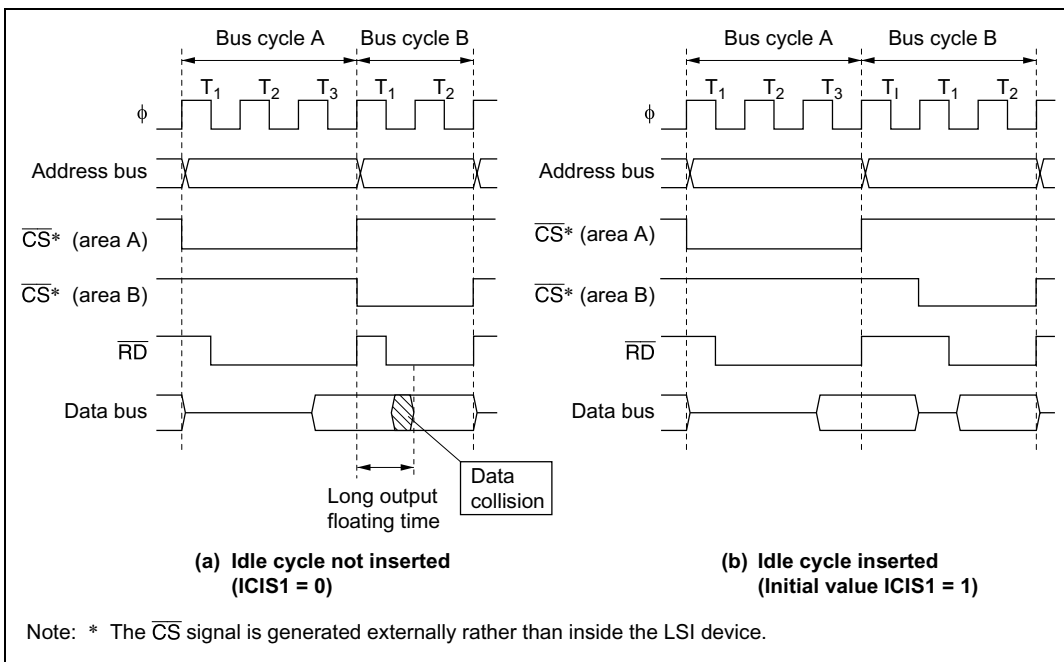

Figure 7-15 Example of Idle Cycle Operation (1)

(2) Write after Read

If an external write occurs after an external read while the ICIS0 bit in BCRH is set to 1, an idle cycle is inserted at the start of the write cycle.

Figure 7-16 shows an example of the operation in this case. In this example, bus cycle A is a read cycle from ROM with a long output floating time, and bus cycle B is a CPU write cycle. In (a), an idle cycle is not inserted, and a collision occurs in cycle B between the read data from ROM and the CPU write data. In (b), an idle cycle is inserted, and a data collision is prevented.

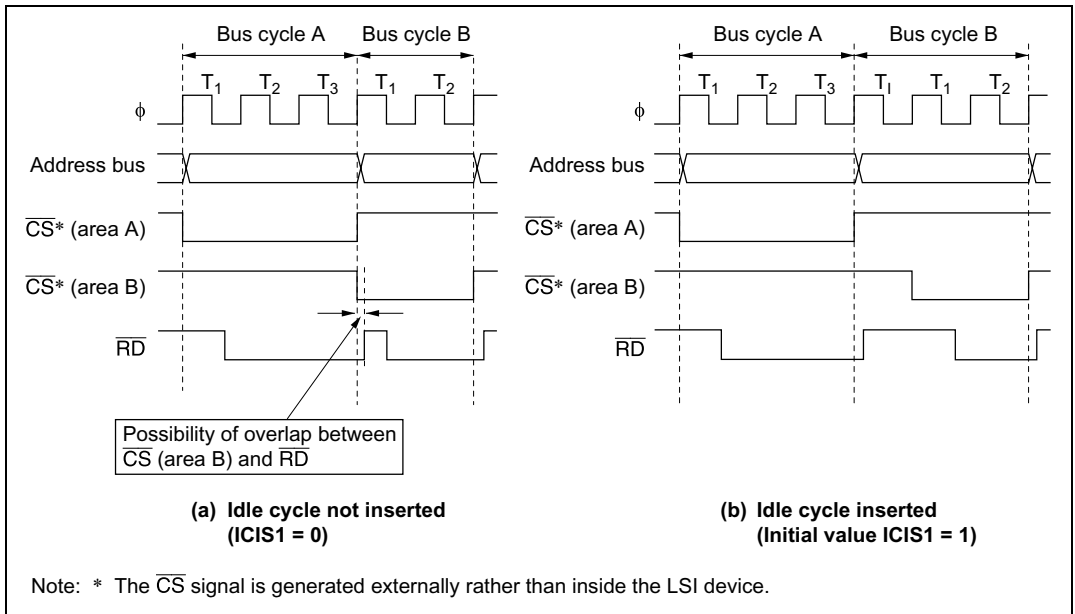

Figure 7-16 Example of Idle Cycle Operation (2)

(3) Relationship between Chip Select (\overline{CS}^*) Signal and Read (\overline{RD}) Signal

Depending on the system's load conditions, the \overline{RD} signal may lag behind the \overline{CS}^* signal*. An example is shown in figure 7-17.

In this case, with the setting for no idle cycle insertion (a), there may be a period of overlap between the bus cycle A \overline{RD} signal and the bus cycle B \overline{CS}^* signal.

Setting idle cycle insertion, as in (b), however, will prevent any overlap between the \overline{RD} and \overline{CS}^* signals.

In the initial state after reset release, idle cycle insertion (b) is set.

Note: * The \overline{CS}^* signal is generated externally rather than inside the LSI device.

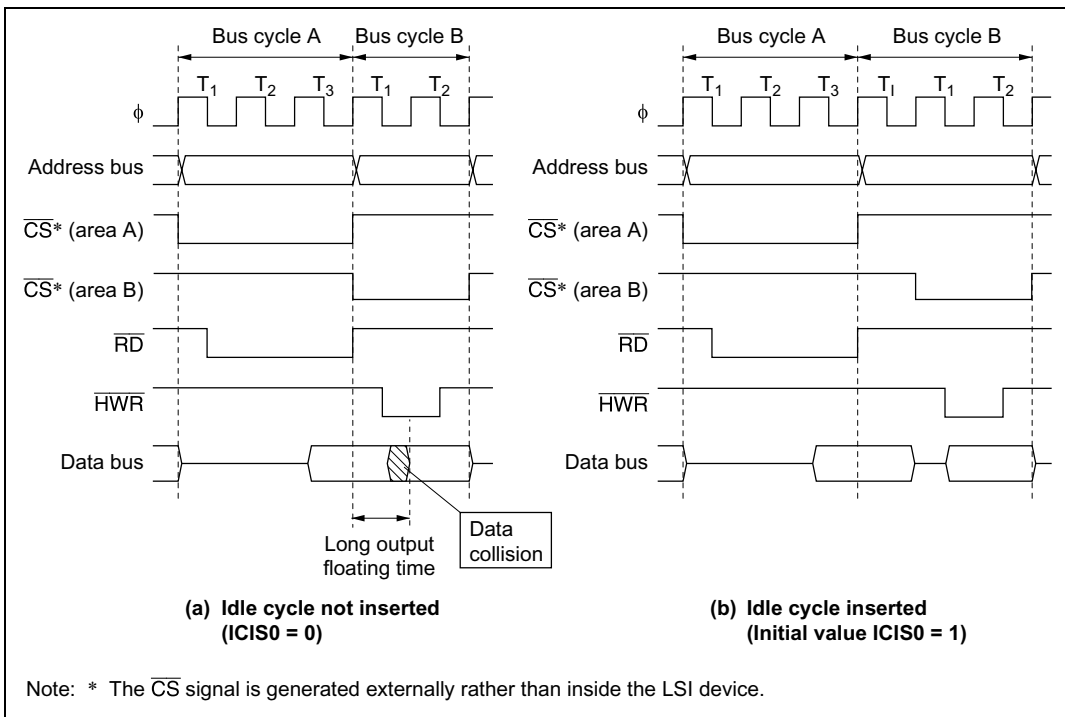

Figure 7-17 Relationship between Chip Select (\overline{CS}^*) and Read (\overline{RD})

7.6.2 Pin States During Idle Cycles

Table 7-5 shows the pin states during idle cycles.

Table 7-5 Pin States During Idle Cycles

Pins	Pin State
A23 to A0	Content identical to immediately following bus cycle
D15 to D0	High impedance
\overline{AS}	High level
\overline{RD}	High level
\overline{HWR}	High level
\overline{LWR}	High level

7.7 Write Data Buffer Function

The chip has a write data buffer function in the external data bus. Using this function enables the write data buffer to be accessed in parallel. The write data buffer function is made available by setting the WDBE bit in BCRL to 1.

Figure 7-18 shows an example of the timing when the write data buffer function is used. When this function is used, if an external write continues for 2 states or longer, and there is an internal access next, only an external write is executed in the first state, but from the next state onward an internal access (on-chip memory or internal I/O register read/write) is executed in parallel with the external write rather than waiting until it ends.

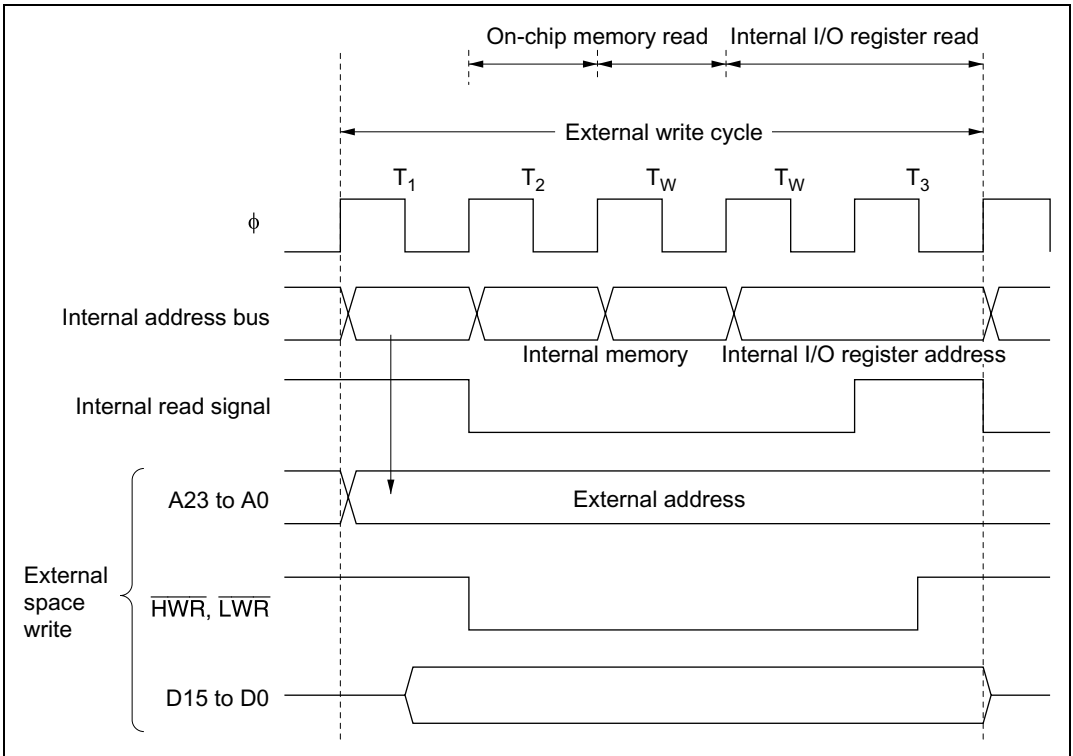

Figure 7-18 Example of Timing when Write Data Buffer Function Is Used

7.8 Bus Arbitration

Note: The H8S/2635 Group is not equipped with a DTC.

7.8.1 Overview

The chip has a bus arbiter that arbitrates bus master operations.

There are two bus masters, the CPU and DTC which perform read/write operations when they have possession of the bus. Each bus master requests the bus by means of a bus request signal. The bus arbiter determines priorities at the prescribed timing, and permits use of the bus by means of a bus request acknowledge signal. The selected bus master then takes possession of the bus and begins its operation.

7.8.2 Operation

The bus arbiter detects the bus masters' bus request signals, and if the bus is requested, sends a bus request acknowledge signal to the bus master making the request. If there are bus requests from more than one bus master, the bus request acknowledge signal is sent to the one with the highest priority. When a bus master receives the bus request acknowledge signal, it takes possession of the bus until that signal is canceled.

The order of priority of the bus masters is as follows:

(High) DTC > CPU (Low)

7.8.3 Bus Transfer Timing

Even if a bus request is received from a bus master with a higher priority than that of the bus master that has acquired the bus and is currently operating, the bus is not necessarily transferred immediately. There are specific times at which each bus master can relinquish the bus.

CPU: The CPU is the lowest-priority bus master, and if a bus request is received from the DTC, the bus arbiter transfers the bus to the bus master that issued the request. The timing for transfer of the bus is as follows:

- The bus is transferred at a break between bus cycles. However, if a bus cycle is executed in discrete operations, as in the case of a longword-size access, the bus is not transferred between the operations. See Appendix A.5, Bus States during Instruction Execution, for timings at which the bus is not transferred.
- If the CPU is in sleep mode, it transfers the bus immediately.

DTC: The DTC sends the bus arbiter a request for the bus when an activation request is generated.

The DTC can release the bus after a vector read, a register information read (3 states), a single data transfer, or a register information write (3 states). It does not release the bus during a register information read (3 states), a single data transfer, or a register information write (3 states).

7.9 Resets and the Bus Controller

In a reset, the chip, including the bus controller, enters the reset state at that point, and an executing bus cycle is discontinued.

Section 8 Data Transfer Controller (DTC)

Note: The H8S/2635 Group is not equipped with a DTC.

8.1 Overview

The chip includes a data transfer controller (DTC). The DTC can be activated by an interrupt or software, to transfer data.

8.1.1 Features

- Transfer possible over any number of channels
 - Transfer information is stored in memory
 - One activation source can trigger a number of data transfers (chain transfer)
- Wide range of transfer modes
 - Normal, repeat, and block transfer modes available
 - Incrementing, decrementing, and fixing of source and destination addresses can be selected
- Direct specification of 16-Mbyte address space possible
 - 24-bit transfer source and destination addresses can be specified
- Transfer can be set in byte or word units
- A CPU interrupt can be requested for the interrupt that activated the DTC
 - An interrupt request can be issued to the CPU after one data transfer ends
 - An interrupt request can be issued to the CPU after the specified data transfers have completely ended
- Activation by software is possible
- Module stop mode can be set
 - The initial setting enables DTC registers to be accessed. DTC operation is halted by setting module stop mode.

8.1.2 Block Diagram

Figure 8-1 shows a block diagram of the DTC.

The DTC's register information is stored in the on-chip RAM*. A 32-bit bus connects the DTC to the on-chip RAM (1 kbyte), enabling 32-bit/1-state reading and writing of the DTC register information.

Note: * When the DTC is used, the RAME bit in SYSCR must be set to 1.

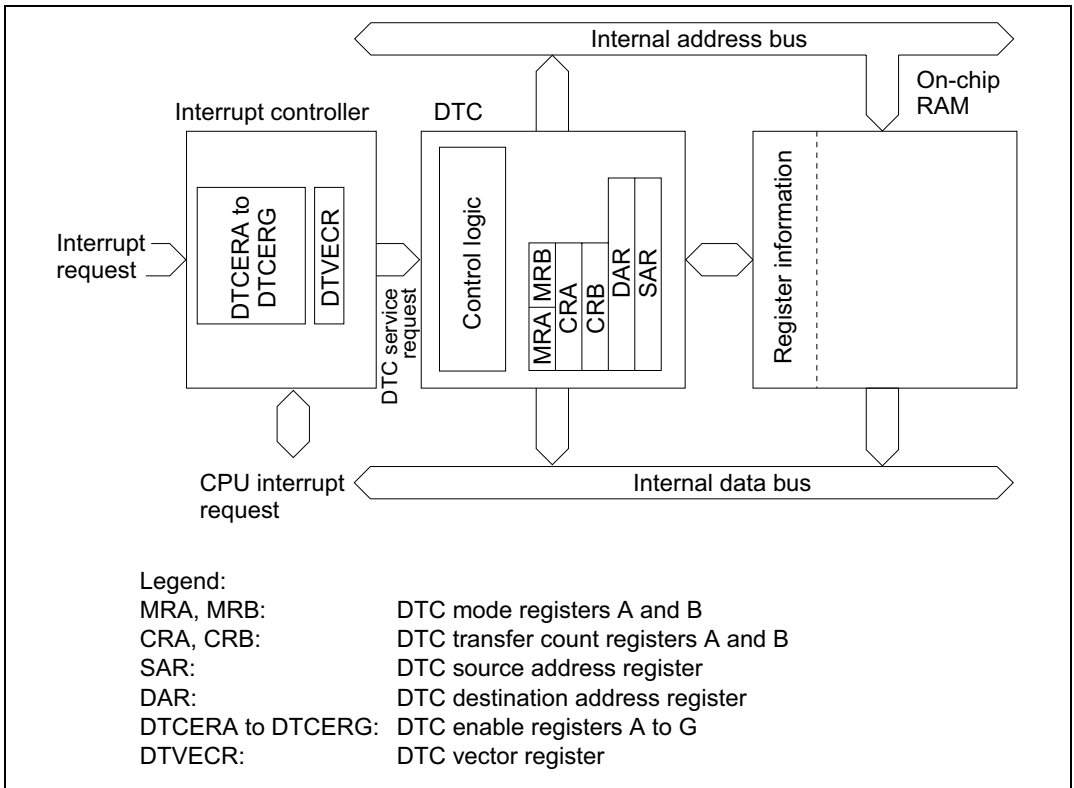

Figure 8-1 Block Diagram of DTC

8.1.3 Register Configuration

Table 8-1 summarizes the DTC registers.

Table 8-1 DTC Registers

Name	Abbreviation	R/W	Initial Value	Address*1
DTC mode register A	MRA	—*2	Undefined	—*3
DTC mode register B	MRB	—*2	Undefined	—*3
DTC source address register	SAR	—*2	Undefined	—*3
DTC destination address register	DAR	—*2	Undefined	—*3
DTC transfer count register A	CRA	—*2	Undefined	—*3
DTC transfer count register B	CRB	—*2	Undefined	—*3
DTC enable registers	DT CER	R/W	H'00	H'FE16 to H'FE1C
DTC vector register	DTVECR	R/W	H'00	H'FE1F
Module stop control register A	MSTPCRA	R/W	H'3F	H'FDE8

Notes: 1. Lower 16 bits of the address.

2. Registers within the DTC cannot be read or written to directly.

3. Register information is located in on-chip RAM addresses H'EBC0 to H'EFBF. It cannot be located in external memory space. When the DTC is used, do not clear the RAME bit in SYSCR to 0.

8.2 Register Descriptions

8.2.1 DTC Mode Register A (MRA)

Bit	:	7	6	5	4	3	2	1	0
		SM1	SM0	DM1	DM0	MD1	MD0	DTS	Sz
Initial value	:	*	*	*	*	*	*	*	*
R/W	:	—	—	—	—	—	—	—	—

*: Undefined

MRA is an 8-bit register that controls the DTC operating mode.

Bits 7 and 6—Source Address Mode 1 and 0 (SM1, SM0): These bits specify whether SAR is to be incremented, decremented, or left fixed after a data transfer.

Bit 7	Bit 6	Description
SM1	SM0	
0	—	SAR is fixed
1	0	SAR is incremented after a transfer (by +1 when Sz = 0; by +2 when Sz = 1)
	1	SAR is decremented after a transfer (by -1 when Sz = 0; by -2 when Sz = 1)

Bits 5 and 4—Destination Address Mode 1 and 0 (DM1, DM0): These bits specify whether DAR is to be incremented, decremented, or left fixed after a data transfer.

Bit 5	Bit 4	Description
DM1	DM0	
0	—	DAR is fixed
1	0	DAR is incremented after a transfer (by +1 when Sz = 0; by +2 when Sz = 1)
	1	DAR is decremented after a transfer (by -1 when Sz = 0; by -2 when Sz = 1)

Bits 3 and 2—DTC Mode (MD1, MD0): These bits specify the DTC transfer mode.

Bit 3	Bit 2	
MD1	MD0	Description
0	0	Normal mode
	1	Repeat mode
1	0	Block transfer mode
	1	—

Bit 1—DTC Transfer Mode Select (DTS): Specifies whether the source side or the destination side is set to be a repeat area or block area, in repeat mode or block transfer mode.

Bit 1	
DTS	Description
0	Destination side is repeat area or block area
1	Source side is repeat area or block area

Bit 0—DTC Data Transfer Size (Sz): Specifies the size of data to be transferred.

Bit 0	
Sz	Description
0	Byte-size transfer
1	Word-size transfer

8.2.2 DTC Mode Register B (MRB)

Bit	:	7	6	5	4	3	2	1	0
		CHNE	DISEL	—	—	—	—	—	—
Initial value:		*	*	*	*	*	*	*	*
R/W	:	—	—	—	—	—	—	—	—

*: Undefined

MRB is an 8-bit register that controls the DTC operating mode.

Bit 7—DTC Chain Transfer Enable (CHNE): Specifies chain transfer. With chain transfer, a number of data transfers can be performed consecutively in response to a single transfer request.

In data transfer with CHNE set to 1, determination of the end of the specified number of transfers, clearing of the interrupt source flag, and clearing of DTCER is not performed.

Bit 7

CHNE	Description
0	End of DTC data transfer (activation waiting state is entered)
1	DTC chain transfer (new register information is read, then data is transferred)

Bit 6—DTC Interrupt Select (DISEL): Specifies whether interrupt requests to the CPU are disabled or enabled after a data transfer.

Bit 6

DISEL	Description
0	After a data transfer ends, the CPU interrupt is disabled unless the transfer counter is 0 (the DTC clears the interrupt source flag of the activating interrupt to 0)
1	After a data transfer ends, the CPU interrupt is enabled (the DTC does not clear the interrupt source flag of the activating interrupt to 0)

Bits 5 to 0—Reserved: These bits have no effect on DTC operation in the chip, and should always be written with 0.

8.2.3 DTC Source Address Register (SAR)

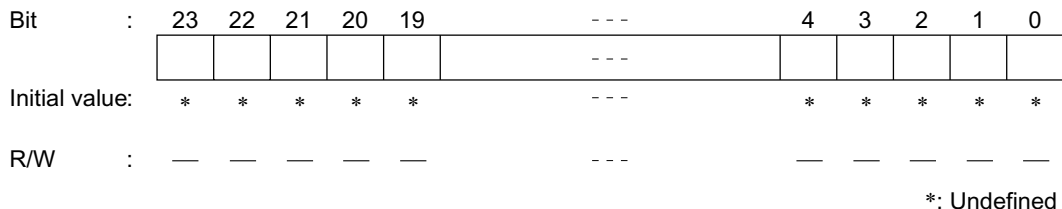

SAR is a 24-bit register that designates the source address of data to be transferred by the DTC. For word-size transfer, specify an even source address.

8.2.4 DTC Destination Address Register (DAR)

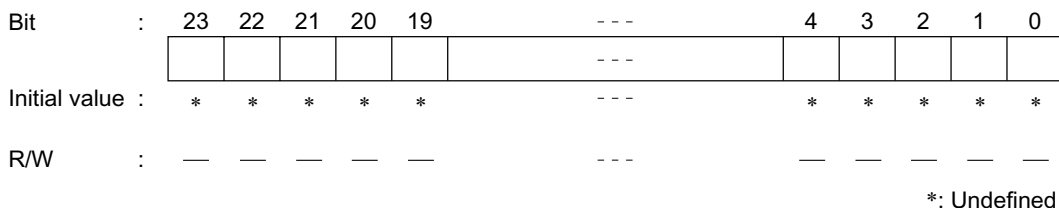

DAR is a 24-bit register that designates the destination address of data to be transferred by the DTC. For word-size transfer, specify an even destination address.

8.2.5 DTC Transfer Count Register A (CRA)

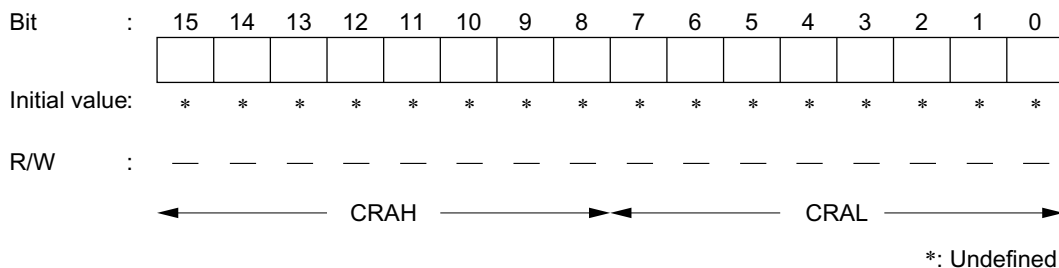

CRA is a 16-bit register that designates the number of times data is to be transferred by the DTC.

In normal mode, the entire CRA functions as a 16-bit transfer counter (1 to 65536). It is decremented by 1 every time data is transferred, and transfer ends when the count reaches H'0000.

In repeat mode or block transfer mode, the CRA is divided into two parts: the upper 8 bits (CRAH) and the lower 8 bits (CRAL). CRAH holds the number of transfers while CRAL functions as an 8-bit transfer counter (1 to 256). CRAL is decremented by 1 every time data is transferred, and the contents of CRAH are sent when the count reaches H'00. This operation is repeated.

8.2.6 DTC Transfer Count Register B (CRB)

Bit	:	15	14	13	12	11	10	9	8	7	6	5	4	3	2	1	0
Initial value:		*	*	*	*	*	*	*	*	*	*	*	*	*	*	*	*
R/W	:	—	—	—	—	—	—	—	—	—	—	—	—	—	—	—	—

*: Undefined

CRB is a 16-bit register that designates the number of times data is to be transferred by the DTC in block transfer mode. It functions as a 16-bit transfer counter (1 to 65,536) that is decremented by 1 every time data is transferred, and transfer ends when the count reaches H'0000.

8.2.7 DTC Enable Registers (DTCER)

Bit	:	7	6	5	4	3	2	1	0
		DTCE7	DTCE6	DTCE5	DTCE4	DTCE3	DTCE2	DTCE1	DTCE0
Initial value:		0	0	0	0	0	0	0	0
R/W	:	R/W	R/W	R/W	R/W	R/W	R/W	R/W	R/W

The DTC enable registers comprise seven 8-bit readable/writable registers, DTCERA to DTCERG with bits corresponding to the interrupt sources that can control enabling and disabling of DTC activation. These bits enable or disable DTC service for the corresponding interrupt sources.

The DTC enable registers are initialized to H'00 by a reset and in hardware standby mode.

Bit n—DTC Activation Enable (DTCEn)**Bit n**

DTCEn	Description
0	DTC activation by this interrupt is disabled (Initial value) [Clearing conditions] <ul style="list-style-type: none"> • When the DISEL bit is 1 and the data transfer has ended • When the specified number of transfers have ended
1	DTC activation by this interrupt is enabled [Holding condition] <ul style="list-style-type: none"> • When the DISEL bit is 0 and the specified number of transfers have not ended

(n = 7 to 0)

A DTCE bit can be set for each interrupt source that can activate the DTC. The correspondence between interrupt sources and DTCE bits is shown in table 8-4, together with the vector number generated for each interrupt controller.

For DTCE bit setting, use bit manipulation instructions such as BSET and BCLR for reading and writing. If all interrupts are masked, multiple activation sources can be set at one time by writing data after executing a dummy read on the relevant register.

8.2.8 DTC Vector Register (DTVECR)

Bit	:	7	6	5	4	3	2	1	0
		SWDTE	DTVEC6	DTVEC5	DTVEC4	DTVEC3	DTVEC2	DTVEC1	DTVEC0
Initial value:		0	0	0	0	0	0	0	0
R/W	:	R/(W)*1	R/W*2	R/W*2	R/W*2	R/W*2	R/W*2	R/W*2	R/W*2

- Notes: 1. Only 1 can be written to the SWDTE bit.
2. Bits DTVEC6 to DTVEC0 can be written to when SWDTE = 0.

DTVECR is an 8-bit readable/writable register that enables or disables DTC activation by software, and sets a vector number for the software activation interrupt.

DTVECR is initialized to H'00 by a reset and in hardware standby mode.

Bit 7—DTC Software Activation Enable (SWDTE): Enables or disables DTC activation by software.

Bit 7

SWDTE	Description
0	DTC software activation is disabled (Initial value) [Clearing conditions] <ul style="list-style-type: none">• When the DISEL bit is 0 and the specified number of transfers have not ended• When 0 is written to the DISEL bit after a software-activated data transfer end interrupt (SWDTEND) request has been sent to the CPU
1	DTC software activation is enabled [Holding conditions] <ul style="list-style-type: none">• When the DISEL bit is 1 and data transfer has ended• When the specified number of transfers have ended• During data transfer due to software activation

Bits 6 to 0—DTC Software Activation Vectors 6 to 0 (DTVEC6 to DTVEC0): These bits specify a vector number for DTC software activation.

The vector address is expressed as $H'0400 + ((\text{vector number}) \ll 1)$. $\ll 1$ indicates a one-bit left-shift. For example, when $DTVEC6$ to $DTVEC0 = H'10$, the vector address is $H'0420$.

8.2.9 Module Stop Control Register A (MSTPCRA)

Bit	7	6	5	4	3	2	1	0
	MSTPA7	MSTPA6	MSTPA5	MSTPA4	MSTPA3	MSTPA2	MSTPA1	MSTPA0
Initial value	0	0	1	1	1	1	1	1
Read/Write	R/W	R/W	R/W	R/W	R/W	R/W	R/W	R/W

MSTPCRA is a 8-bit readable/writable register that performs module stop mode control.

When the MSTPA6 bit in MSTPCRA is set to 1, the DTC operation stops at the end of the bus cycle and a transition is made to module stop mode. However, 1 cannot be written in the MSTPA6 bit while the DTC is operating. For details, see section 23A.5, 23B.5, Module Stop Mode.

MSTPCRA is initialized to H'3F by a reset and in hardware standby mode. It is not initialized in software standby mode.

Bit 6—Module Stop (MSTPA6): Specifies the DTC module stop mode.

Bit 6

MSTPA6	Description
0	DTC module stop mode cleared (Initial value)
1	DTC module stop mode set

8.3 Operation

8.3.1 Overview

When activated, the DTC reads register information that is already stored in memory and transfers data on the basis of that register information. After the data transfer, it writes updated register information back to memory. Pre-storage of register information in memory makes it possible to transfer data over any required number of channels. Setting the CHNE bit to 1 makes it possible to perform a number of transfers with a single activation.

Figure 8-2 shows a flowchart of DTC operation.

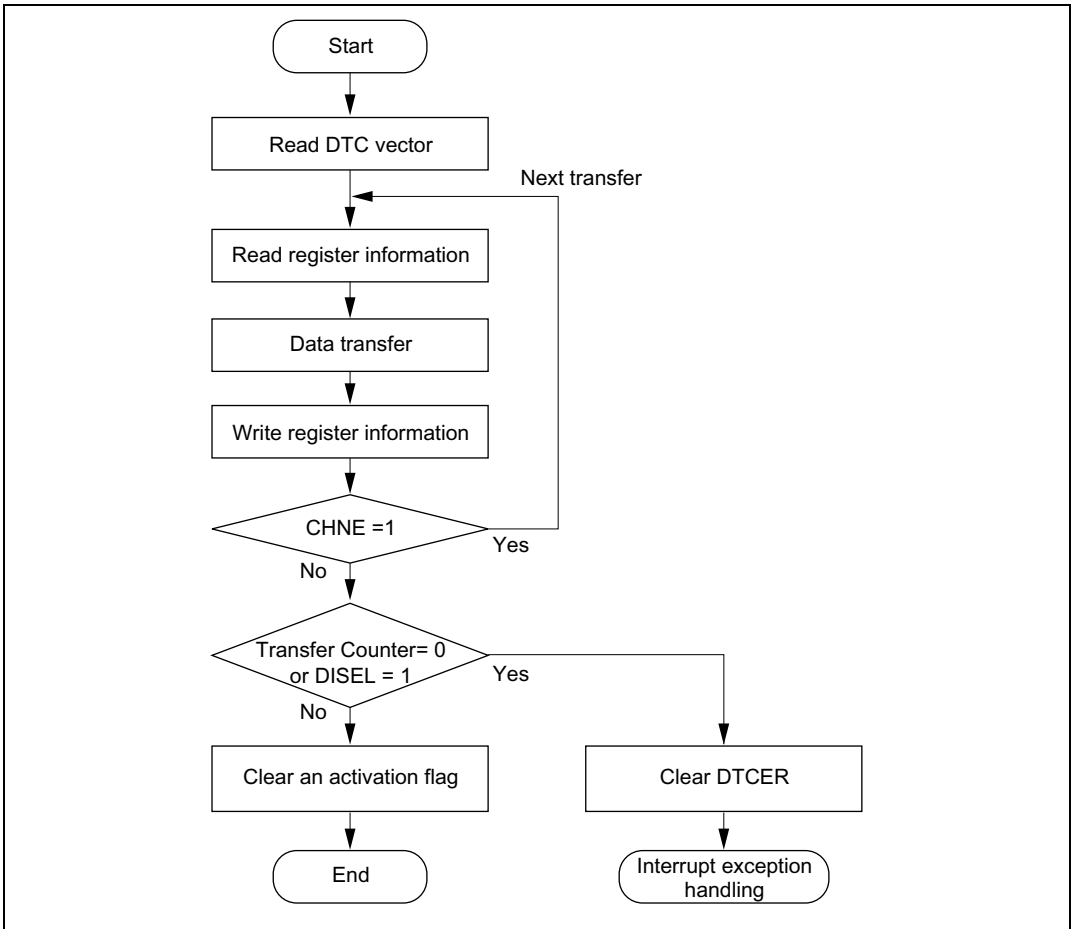

Figure 8-2 Flowchart of DTC Operation

The DTC transfer mode can be normal mode, repeat mode, or block transfer mode.

The 24-bit SAR designates the DTC transfer source address and the 24-bit DAR designates the transfer destination address. After each transfer, SAR and DAR are independently incremented, decremented, or left fixed.

Table 8-2 outlines the functions of the DTC.

Table 8-2 DTC Functions

Transfer Mode	Activation Source	Address Registers	
		Transfer Source	Transfer Destination
<ul style="list-style-type: none"> • Normal mode <ul style="list-style-type: none"> — One transfer request transfers one byte or one word — Memory addresses are incremented or decremented by 1 or 2 — Up to 65,536 transfers possible • Repeat mode <ul style="list-style-type: none"> — One transfer request transfers one byte or one word — Memory addresses are incremented or decremented by 1 or 2 — After the specified number of transfers (1 to 256), the initial state resumes and operation continues • Block transfer mode <ul style="list-style-type: none"> — One transfer request transfers a block of the specified size — Block size is from 1 to 256 bytes or words — Up to 65,536 transfers possible — A block area can be designated at either the source or destination 	<ul style="list-style-type: none"> • IRQ • TPU TGI • SCI TXI or RXI • A/D converter ADI • Motor control PWM CMI • HCAN RMO (mail box 0) • Software 	24 bits	24 bits

8.3.2 Activation Sources

The DTC operates when activated by an interrupt or by a write to DTVECR by software. An interrupt request can be directed to the CPU or DTC, as designated by the corresponding DTCER bit. An interrupt becomes a DTC activation source when the corresponding bit is set to 1, and a CPU interrupt source when the bit is cleared to 0.

At the end of a data transfer (or the last consecutive transfer in the case of chain transfer), the activation source or corresponding DTCER bit is cleared. Table 8-3 shows activation source and DTCER clearance. The activation source flag, in the case of RXI0, for example, is the RDRF flag of SCIO.

Table 8-3 Activation Source and DTCER Clearance

Activation Source	When the DIESEL Bit Is 0 and the Specified Number of Transfers Have not Ended	When the DIESEL Bit Is 1, or when the Specified Number of Transfers Have Ended
Software activation	The SWDTE bit is cleared to 0	The SWDTE bit remains set to 1 An interrupt is issued to the CPU
Interrupt activation	The corresponding DTCER bit remains set to 1 The activation source flag is cleared to 0	The corresponding DTCER bit is cleared to 0 The activation source flag remains set to 1 A request is issued to the CPU for the activation source interrupt

Figure 8-3 shows a block diagram of activation source control. For details see section 5, Interrupt Controller.

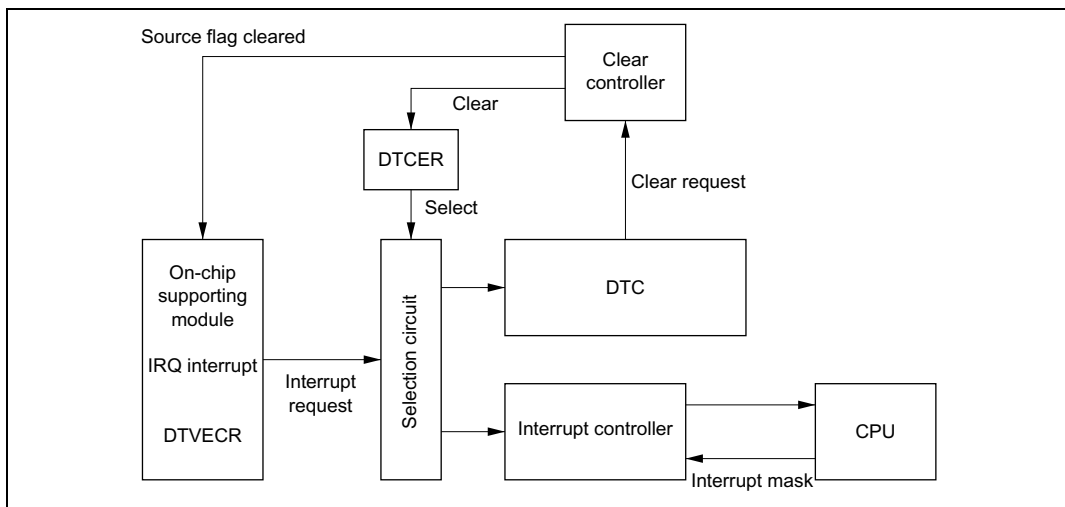

Figure 8-3 Block Diagram of DTC Activation Source Control

When an interrupt has been designated a DTC activation source, existing CPU mask level and interrupt controller priorities have no effect. If there is more than one activation source at the same time, the DTC operates in accordance with the default priorities.

8.3.3 DTC Vector Table

Figure 8-4 shows the correspondence between DTC vector addresses and register information.

Table 8-4 shows the correspondence between activation and vector addresses. When the DTC is activated by software, the vector address is obtained from: $H'0400 + (DTVECR[6:0] \ll 1)$ (where $\ll 1$ indicates a 1-bit left shift). For example, if DTVECR is H'10, the vector address is H'0420.

The DTC reads the start address of the register information from the vector address set for each activation source, and then reads the register information from that start address. The register information can be placed at predetermined addresses in the on-chip RAM. The start address of the register information should be an integral multiple of four.

The configuration of the vector address is the same in both normal* and advanced modes, a 2-byte unit being used in both cases. These two bytes specify the lower bits of the address in the on-chip RAM.

Note: * Not available in the chip.

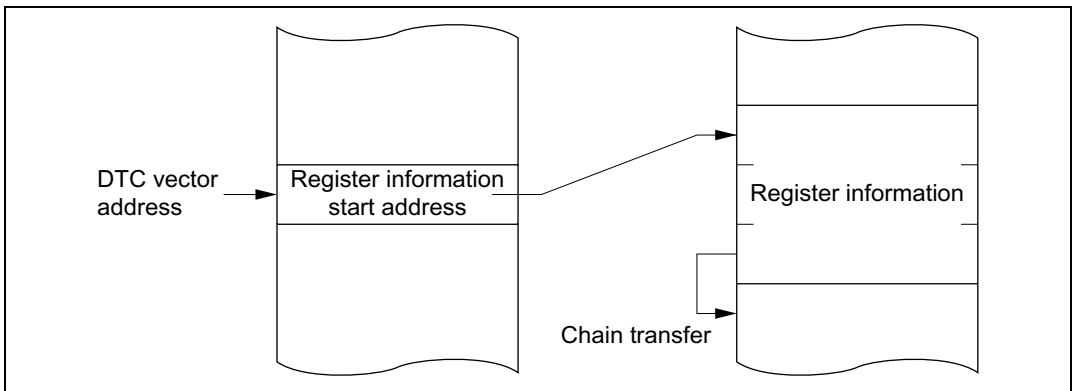

Figure 8-4 Correspondence between DTC Vector Address and Register Information

Table 8-4 Interrupt Sources, DTC Vector Addresses, and Corresponding DTCEs

Interrupt Source	Origin of Interrupt Source	Vector Number	Vector Address	DTCE*1	Priority	
Write to DTVECR	Software	DTVECR	H'0400+ (DTVECR [6:0] <<1)	—	High ↑	
IRQ0	External pin	16	H'0420	DTCEA7	↑	
IRQ1		17	H'0422	DTCEA6		
IRQ2		18	H'0424	DTCEA5		
IRQ3		19	H'0426	DTCEA4		
IRQ4		20	H'0428	DTCEA3		
IRQ5		21	H'042A	DTCEA2		
Reserved	—	22 to 27	H'042C to H'0436	—	↑	
ADI (A/D conversion end)	A/D	28	H'0438	DTCEB6		
Reserved	—	29 to 31	H'043A to H'043E	—		
TGI0A (GR0A compare match/ input capture)	TPU channel 0	32	H'0440	DTCEB5		
TGI0B (GR0B compare match/ input capture)		33	H'0442	DTCEB4		
TGI0C (GR0C compare match/ input capture)		34	H'0444	DTCEB3		
TGI0D (GR0D compare match/ input capture)		35	H'0446	DTCEB2		
Reserved		—	36 to 39	H'0448 to H'044E		—
TGI1A (GR1A compare match/ input capture)	TPU channel 1	40	H'0450	DTCEB1		
TGI1B (GR1B compare match/ input capture)		41	H'0452	DTCEB0		
TGI2A (GR2A compare match/ input capture)	TPU channel 2	44	H'0458	DTCEC7		
TGI2B (GR2B compare match/ input capture)		45	H'045A	DTCEC6		
						Low

Interrupt Source	Origin of Interrupt Source	Vector Number	Vector Address	DTCE* ¹	Priority
TGI3A (GR3A compare match/ input capture)	TPU channel 3	48	H'0460	DTCEC5	↑ High
TGI3B (GR3B compare match/ input capture)		49	H'0462	DTCEC4	
TGI3C (GR3C compare match/ input capture)		50	H'0464	DTCEC3	
TGI3D (GR3D compare match/ input capture)		51	H'0466	DTCEC2	
Reserved	—	52 to 55	H'0468 to H'046E	—	
TGI4A (GR4A compare match/ input capture)	TPU channel 4	56	H'0470	DTCEC1	
TGI4B (GR4B compare match/ input capture)		57	H'0472	DTCEC0	
Reserved	—	58, 59	H'0474 to H'0476	—	
TGI5A (GR5A compare match/ input capture)	TPU channel 5	60	H'0478	DTCED5	
TGI5B (GR5B compare match/ input capture)		61	H'047A	DTCED4	
Reserved	—	62 to 80	H'047C to H'04A0	—	
RXI0 (reception complete 0)	SCI channel 0	81	H'04A2	DTCEE3	
TXI0 (transmit data empty 0)		82	H'04A4	DTCEE2	
Reserved	—	83, 84	H'04A6 to H'04A8	—	
RXI1 (reception complete 1)	SCI channel 1	85	H'04AA	DTCEE1	
TXI1 (transmit data empty 1)		86	H'04AC	DTCEE0	
Reserved	—	87, 88	H'04AE to H'04B0	—	
RXI2 (reception complete 2)	SCI channel 2	89	H'04B2	DTCEF7	
TXI2 (transmit data empty 2)		90	H'04B4	DTCEF6	
Reserved	—	91 to 97	H'04B6 to H'04C2	—	Low

Interrupt Source	Origin of Interrupt Source	Vector Number	Vector Address	DTCE* ¹	Priority
I ² Ci0 (1-byte transmission/reception completed)* ²	I ² C channel 0 (option)	100	H'04C8	DTCEF1	High
I ² Ci1 (1-byte transmission/reception completed)* ²	I ² C channel 1 (option)	102	H'04CC	DTCEF0	
CMI1 (PWCYR1 compare match)	PWM	104	H'04D0	DTCEG7	
CMI2 (PWCYR2 compare match)		105	H'04D2	DTCEG6	
Reserved	—	106	H'04D4	—	
RM0 (HCAN1 mail box 0)	HCAN1	107	H'04D6	DTCEG4	
Reserved	—	108	H'04D8	—	
RM0 (HCAN0 mail box 0)	HCAN0	109	H'04DA	DTCEG2	
Reserved	—	110 to 124	H'04DC to H'04F8	—	Low

- Notes: 1. DTCE bits with no corresponding interrupt are reserved, and should be written with 0.
2. I²C bus interface is available as an option in the H8S/2638, H8S/2639, and H8S/2630. These bits become reserved bits when this optional feature is not used or in the H8S/2636.

8.3.4 Location of Register Information in Address Space

Figure 8-5 shows how the register information should be located in the address space.

Locate the MRA, SAR, MRB, DAR, CRA, and CRB registers, in that order, from the start address of the register information (contents of the vector address). In the case of chain transfer, register information should be located in consecutive areas.

Locate the register information in the on-chip RAM (addresses: H'FFEB0 to H'FFEFBF).

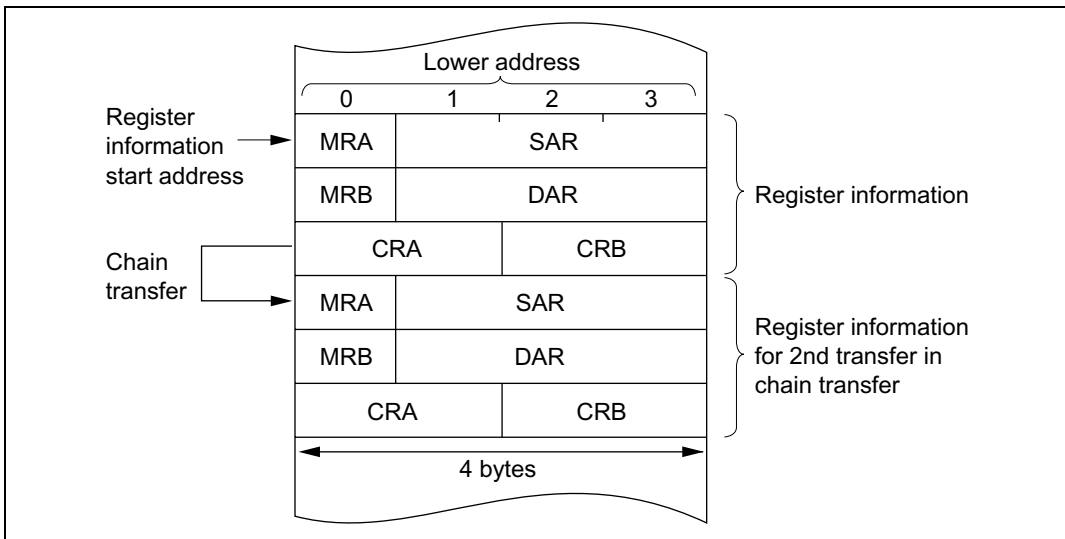

Figure 8-5 Location of Register Information in Address Space

8.3.5 Normal Mode

In normal mode, one operation transfers one byte or one word of data.

From 1 to 65,536 transfers can be specified. Once the specified number of transfers have ended, a CPU interrupt can be requested.

Table 8-5 lists the register information in normal mode and figure 8-6 shows memory mapping in normal mode.

Table 8-5 Register Information in Normal Mode

Name	Abbreviation	Function
DTC source address register	SAR	Designates source address
DTC destination address register	DAR	Designates destination address
DTC transfer count register A	CRA	Designates transfer count
DTC transfer count register B	CRB	Not used

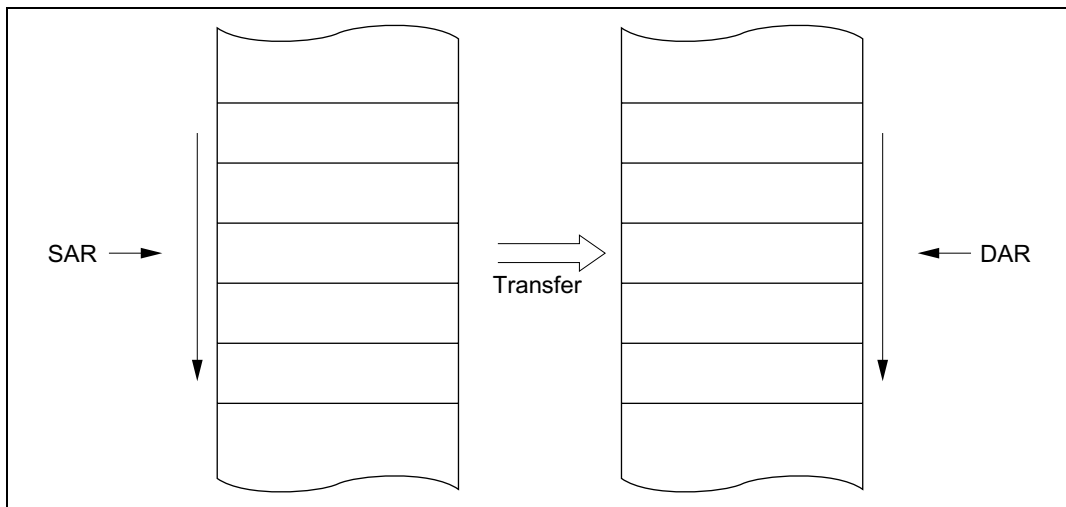

Figure 8-6 Memory Mapping in Normal Mode

8.3.6 Repeat Mode

In repeat mode, one operation transfers one byte or one word of data.

From 1 to 256 transfers can be specified. Once the specified number of transfers have ended, the initial state of the transfer counter and the address register specified as the repeat area is restored, and transfer is repeated. In repeat mode the transfer counter value does not reach H'00, and therefore CPU interrupts cannot be requested when DISEL = 0.

Table 8-6 lists the register information in repeat mode and figure 8-7 shows memory mapping in repeat mode.

Table 8-6 Register Information in Repeat Mode

Name	Abbreviation	Function
DTC source address register	SAR	Designates source address
DTC destination address register	DAR	Designates destination address
DTC transfer count register AH	CRAH	Holds number of transfers
DTC transfer count register AL	CRAL	Designates transfer count
DTC transfer count register B	CRB	Not used

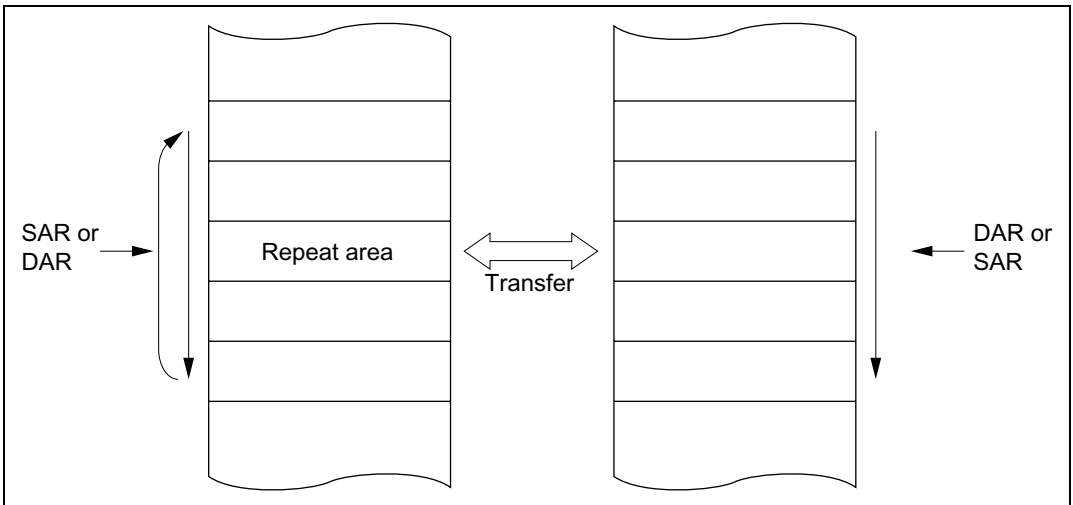

Figure 8-7 Memory Mapping in Repeat Mode

8.3.7 Block Transfer Mode

In block transfer mode, one operation transfers one block of data. Either the transfer source or the transfer destination is designated as a block area.

The block size is 1 to 256. When the transfer of one block ends, the initial state of the block size counter and the address register specified as the block area is restored. The other address register is then incremented, decremented, or left fixed.

From 1 to 65,536 transfers can be specified. Once the specified number of transfers have ended, a CPU interrupt is requested.

Table 8-7 lists the register information in block transfer mode and figure 8-8 shows memory mapping in block transfer mode.

Table 8-7 Register Information in Block Transfer Mode

Name	Abbreviation	Function
DTC source address register	SAR	Designates source address
DTC destination address register	DAR	Designates destination address
DTC transfer count register AH	CRAH	Holds block size
DTC transfer count register AL	CRAL	Designates block size count
DTC transfer count register B	CRB	Transfer count

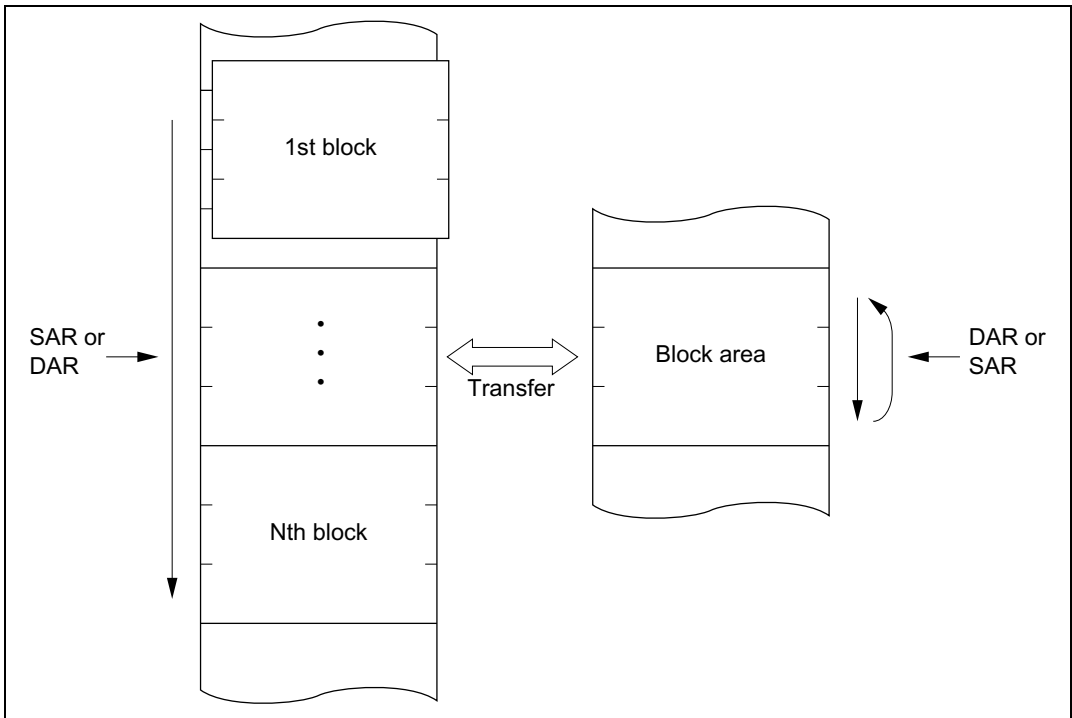

Figure 8-8 Memory Mapping in Block Transfer Mode

8.3.8 Chain Transfer

Setting the CHNE bit to 1 enables a number of data transfers to be performed consecutively in response to a single transfer request. SAR, DAR, CRA, CRB, MRA, and MRB, which define data transfers, can be set independently.

Figure 8-9 shows the memory map for chain transfer.

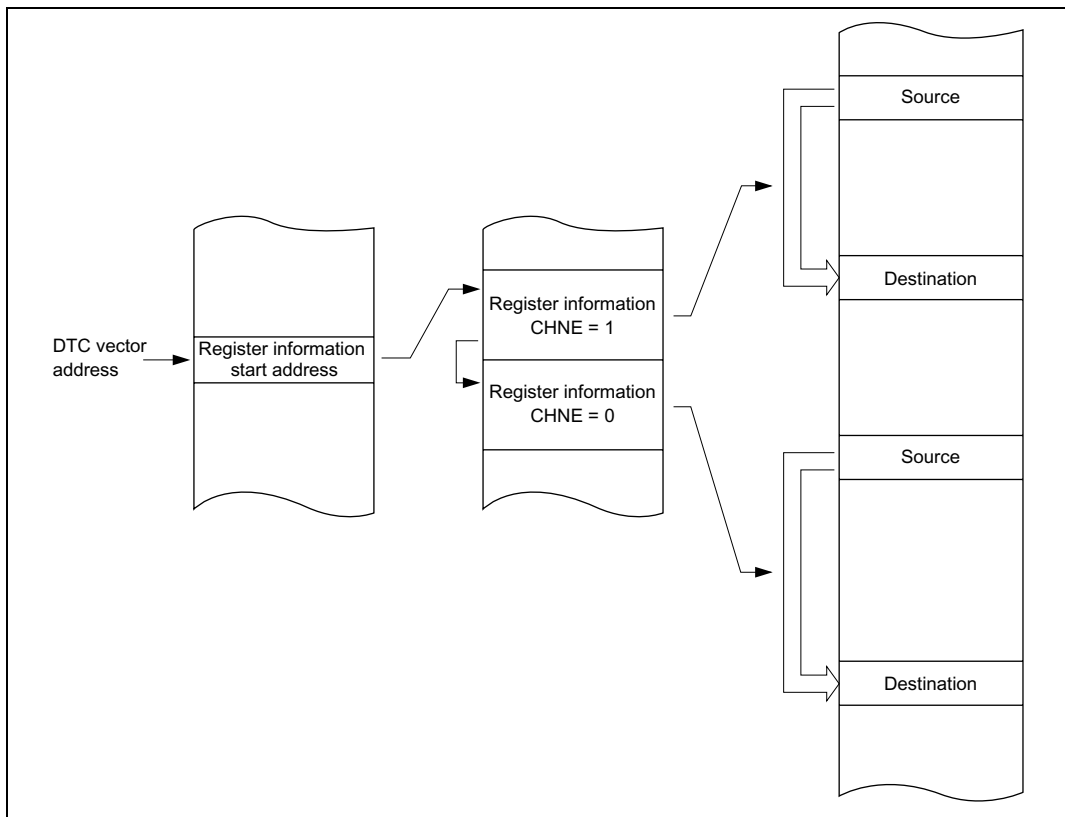

Figure 8-9 Chain Transfer Memory Map

In the case of transfer with CHNE set to 1, an interrupt request to the CPU is not generated at the end of the specified number of transfers or by setting of the DISSEL bit to 1, and the interrupt source flag for the activation source is not affected.

8.3.9 Operation Timing

Figures 8-10 to 8-12 show an example of DTC operation timing.

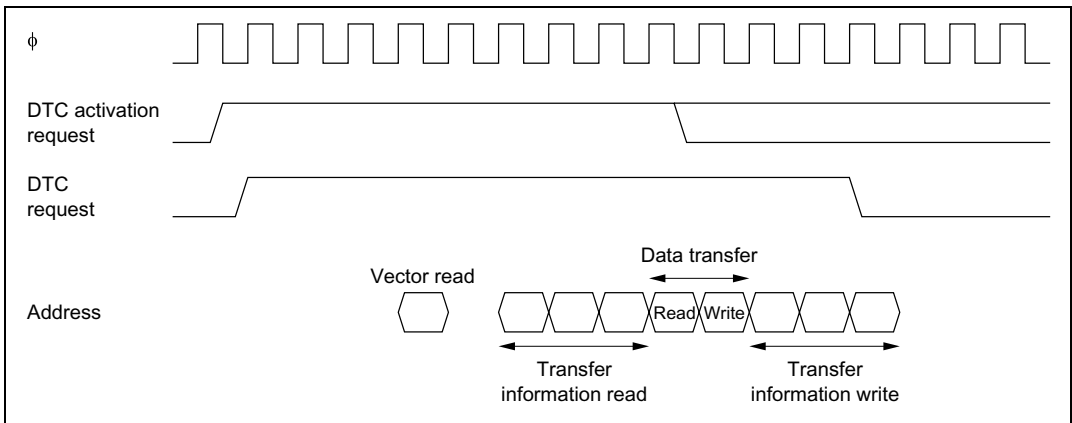

Figure 8-10 DTC Operation Timing (Example in Normal Mode or Repeat Mode)

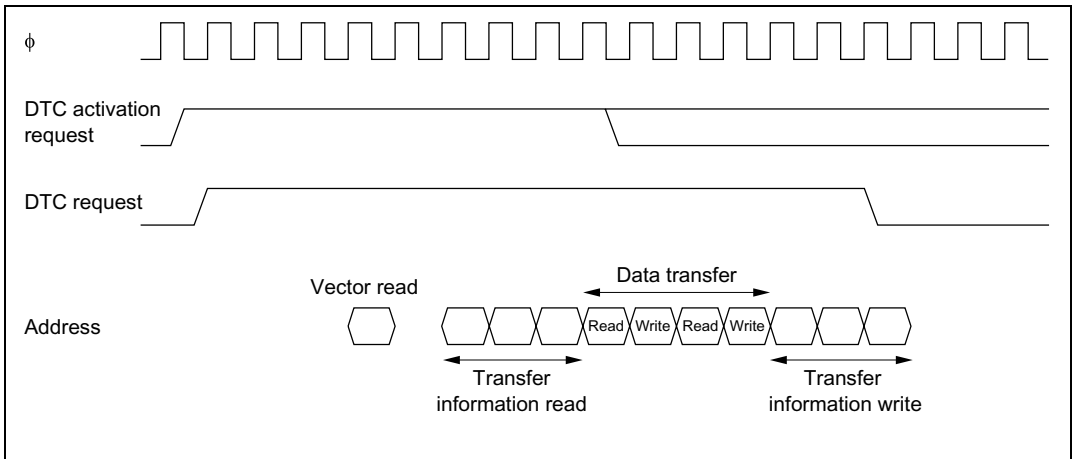

Figure 8-11 DTC Operation Timing (Example of Block Transfer Mode, with Block Size of 2)

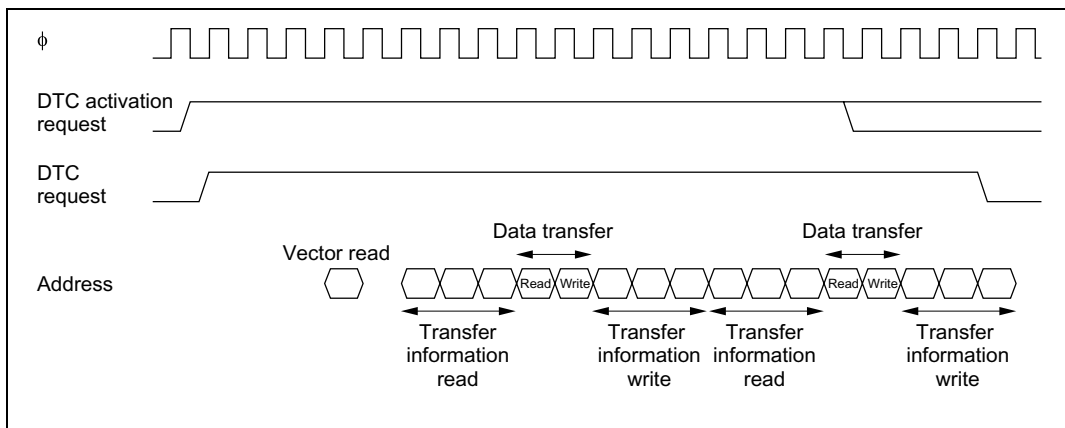

Figure 8-12 DTC Operation Timing (Example of Chain Transfer)

8.3.10 Number of DTC Execution States

Table 8-8 lists execution statuses for a single DTC data transfer, and table 8-9 shows the number of states required for each execution status.

Table 8-8 DTC Execution Statuses

Mode	Vector Read I	Register Information		Data Read K	Data Write L	Internal Operations M
		Read/Write J				
Normal	1	6		1	1	3
Repeat	1	6		1	1	3
Block transfer	1	6		N	N	3

N: Block size (initial setting of CRAH and CRAL)

Table 8-9 Number of States Required for Each Execution Status

Object to be Accessed			On- Chip RAM	On- Chip ROM	On-Chip I/O		External Devices			
			RAM	ROM	Registers					
Bus width			32	16	8	16	8	8	16	16
Access states			1	1	2	2	2	3	2	3
Execution status	Vector read	S _I	—	1	—	—	4	6 + 2m	2	3 + m
	Register information read/write	S _J	1	—	—	—	—	—	—	—
	Byte data read	S _K	1	1	2	2	2	3 + m	2	3 + m
	Word data read	S _K	1	1	4	2	4	6 + 2m	2	3 + m
	Byte data write	S _L	1	1	2	2	2	3 + m	2	3 + m
	Word data write	S _L	1	1	4	2	4	6 + 2m	2	3 + m
	Internal operation	S _M	1	1	1	1	1	1	1	1

The number of execution states is calculated from the formula below. Note that Σ means the sum of all transfers activated by one activation event (the number in which the CHNE bit is set to 1, plus 1).

$$\text{Number of execution states} = I \cdot (S_I + 1) + \Sigma (J \cdot S_J + K \cdot S_K + L \cdot S_L) + M \cdot S_M$$

For example, when the DTC vector address table is located in on-chip ROM, normal mode is set, and data is transferred from the on-chip ROM to an internal I/O register, the time required for the DTC operation is 14 states. The time from activation to the end of the data write is 11 states.

8.3.11 Procedures for Using DTC

Activation by Interrupt: The procedure for using the DTC with interrupt activation is as follows:

- [1] Set the MRA, MRB, SAR, DAR, CRA, and CRB register information in the on-chip RAM.
- [2] Set the start address of the register information in the DTC vector address.
- [3] Set the corresponding bit in DTCER to 1.
- [4] Set the enable bits for the interrupt sources to be used as the activation sources to 1. The DTC is activated when an interrupt used as an activation source is generated.
- [5] After the end of one data transfer, or after the specified number of data transfers have ended, the DTCE bit is cleared to 0 and a CPU interrupt is requested. If the DTC is to continue transferring data, set the DTCE bit to 1.

Activation by Software: The procedure for using the DTC with software activation is as follows:

- [1] Set the MRA, MRB, SAR, DAR, CRA, and CRB register information in the on-chip RAM.
- [2] Set the start address of the register information in the DTC vector address.
- [3] Check that the SWDTE bit is 0.
- [4] Write 1 to SWDTE bit and the vector number to DTVECR.
- [5] Check the vector number written to DTVECR.
- [6] After the end of one data transfer, if the DISEL bit is 0 and a CPU interrupt is not requested, the SWDTE bit is cleared to 0. If the DTC is to continue transferring data, set the SWDTE bit to 1. When the DISEL bit is 1, or after the specified number of data transfers have ended, the SWDTE bit is held at 1 and a CPU interrupt is requested.

8.3.12 Examples of Use of the DTC

(1) Normal Mode

An example is shown in which the DTC is used to receive 128 bytes of data via the SCI.

- [1] Set MRA to fixed source address ($SM1 = SM0 = 0$), incrementing destination address ($DM1 = 1$, $DM0 = 0$), normal mode ($MD1 = MD0 = 0$), and byte size ($Sz = 0$). The DTS bit can have any value. Set MRB for one data transfer by one interrupt ($CHNE = 0$, $DISEL = 0$). Set the SCI RDR address in SAR, the start address of the RAM area where the data will be received in DAR, and 128 (H'0080) in CRA. CRB can be set to any value.
- [2] Set the start address of the register information at the DTC vector address.
- [3] Set the corresponding bit in DTCER to 1.
- [4] Set the SCI to the appropriate receive mode. Set the RIE bit in SCR to 1 to enable the reception complete (RXI) interrupt. Since the generation of a receive error during the SCI reception operation will disable subsequent reception, the CPU should be enabled to accept receive error interrupts.
- [5] Each time reception of one byte of data ends on the SCI, the RDRF flag in SSR is set to 1, an RXI interrupt is generated, and the DTC is activated. The receive data is transferred from RDR to RAM by the DTC. DAR is incremented and CRA is decremented. The RDRF flag is automatically cleared to 0.
- [6] When CRA becomes 0 after the 128 data transfers have ended, the RDRF flag is held at 1, the DTCE bit is cleared to 0, and an RXI interrupt request is sent to the CPU. The interrupt handling routine should perform wrap-up processing.

(2) Chain Transfer

An example of DTC chain transfer is shown in which pulse output is performed using the PPG. Chain transfer can be used to perform pulse output data transfer and PPG output trigger cycle updating. Repeat mode transfer to the PPG's NDR is performed in the first half of the chain transfer, and normal mode transfer to the TPU's TGR in the second half. This is because clearing of the activation source and interrupt generation at the end of the specified number of transfers are restricted to the second half of the chain transfer (transfer when CHNE = 0).

- [1] Perform settings for transfer to the PPG's NDR. Set MRA to source address incrementing ($SM1 = 1$, $SM0 = 0$), fixed destination address ($DM1 = DM0 = 0$), repeat mode ($MD1 = 0$, $MD0 = 1$), and word size ($Sz = 1$). Set the source side as a repeat area ($DTS = 1$). Set MRB to chain mode ($CHNE = 1$, $DISEL = 0$). Set the data table start address in SAR, the NDRH address in DAR, and the data table size in CRAH and CRAL. CRB can be set to any value.
- [2] Perform settings for transfer to the TPU's TGR. Set MRA to source address incrementing ($SM1 = 1$, $SM0 = 0$), fixed destination address ($DM1 = DM0 = 0$), normal mode ($MD1 = MD0 = 0$), and word size ($Sz = 1$). Set the data table start address in SAR, the TGRA address in DAR, and the data table size in CRA. CRB can be set to any value.
- [3] Locate the TPU transfer register information consecutively after the NDR transfer register information.
- [4] Set the start address of the NDR transfer register information to the DTC vector address.
- [5] Set the bit corresponding to TGIA in DTCEr to 1.
- [6] Set TGRA as an output compare register (output disabled) with TIOR, and enable the TGIA interrupt with TIER.
- [7] Set the initial output value in PODR, and the next output value in NDR. Set bits in DDR and NDER for which output is to be performed to 1. Using PCR, select the TPU compare match to be used as the output trigger.
- [8] Set the CST bit in TSTR to 1, and start the TCNT count operation.
- [9] Each time a TGRA compare match occurs, the next output value is transferred to NDR and the set value of the next output trigger period is transferred to TGRA. The activation source TGFA flag is cleared.

[10] When the specified number of transfers are completed (the TPU transfer CRA value is 0), the TGFA flag is held at 1, the DTCE bit is cleared to 0, and a TGIA interrupt request is sent to the CPU. Termination processing should be performed in the interrupt handling routine.

(3) Software Activation

An example is shown in which the DTC is used to transfer a block of 128 bytes of data by means of software activation. The transfer source address is H'1000 and the destination address is H'2000. The vector number is H'60, so the vector address is H'04C0.

- [1] Set MRA to incrementing source address (SM1 = 1, SM0 = 0), incrementing destination address (DM1 = 1, DM0 = 0), block transfer mode (MD1 = 1, MD0 = 0), and byte size (Sz = 0). The DTS bit can have any value. Set MRB for one block transfer by one interrupt (CHNE = 0). Set the transfer source address (H'1000) in SAR, the destination address (H'2000) in DAR, and 128 (H'8080) in CRA. Set 1 (H'0001) in CRB.
- [2] Set the start address of the register information at the DTC vector address (H'04C0).
- [3] Check that the SWDTE bit in DTVECR is 0. Check that there is currently no transfer activated by software.
- [4] Write 1 to the SWDTE bit and the vector number (H'60) to DTVECR. The write data is H'E0.
- [5] Read DTVECR again and check that it is set to the vector number (H'60). If it is not, this indicates that the write failed. This is presumably because an interrupt occurred between steps 3 and 4 and led to a different software activation. To activate this transfer, go back to step 3.
- [6] If the write was successful, the DTC is activated and a block of 128 bytes of data is transferred.
- [7] After the transfer, an SWDTEND interrupt occurs. The interrupt handling routine should clear the SWDTE bit to 0 and perform other wrap-up processing.

8.4 Interrupts

An interrupt request is issued to the CPU when the DTC finishes the specified number of data transfers, or a data transfer for which the DISEL bit was set to 1. In the case of interrupt activation, the interrupt set as the activation source is generated. These interrupts to the CPU are subject to CPU mask level and interrupt controller priority level control.

In the case of activation by software, a software activated data transfer end interrupt (SWDTEND) is generated.

When the DISEL bit is 1 and one data transfer has ended, or the specified number of transfers have ended, after data transfer ends, the SWDTE bit is held at 1 and an SWDTEND interrupt is generated. The interrupt handling routine should clear the SWDTE bit to 0.

When the DTC is activated by software, an SWDTEND interrupt is not generated during a data transfer wait or during data transfer even if the SWDTE bit is set to 1.

8.5 Usage Notes

Module Stop: When the MSTPA6 bit in MSTPCRA is set to 1, the DTC clock stops, and the DTC enters the module stop state. However, 1 cannot be written in the MSTPA6 bit while the DTC is operating.

On-Chip RAM: The MRA, MRB, SAR, DAR, CRA, and CRB registers are all located in on-chip RAM. When the DTC is used, the RAME bit in SYSCR must not be cleared to 0.

DTCE Bit Setting: For DTCE bit setting, use bit manipulation instructions such as BSET and BCLR. If all interrupts are masked, multiple activation sources can be set at one time by writing data after executing a dummy read on the relevant register.

Section 9 I/O Ports

9.1 Overview

The chip has 10 I/O ports (ports 1, 3 and A to F, H, J), and two input-only port (ports 4 and 9).

Table 9-1 summarizes the port functions. The pins of each port also have other functions.

Each I/O port includes a data direction register (DDR) that controls input/output, a data register (DR) that stores output data, and a port register (PORT) used to read the pin states. The input-only ports do not have a DR or DDR register.

Ports A to E have an on-chip pull-up MOS function, and in addition to DR and DDR, have a MOS input pull-up control register (PCR) to control the on/off state of MOS input pull-up.

Ports 3, and A to C include an open-drain control register (ODR) that controls the on/off state of the output buffer PMOS.

When ports 10 to 13 and A to F are used as the output pins for expanded bus control signals, they can drive one TTL load plus a 90pF capacitance load. Those ports in other cases and ports 14 to 17 and 3 can drive one TTL load and a 30pF capacitance load. All I/O ports can drive Darlington transistors when set to output.

Port 1 pins (P16 and P14) and port 3 pins (P35 and P32) and port F (PF3 and PF0) are Schmitt-trigger inputs.

See appendix C, I/O Port Block Diagrams, for a block diagram of each port.

Table 9-1 Port Functions

Port	Description	Pins	Mode 4	Mode 5	Mode 6	Mode 7
Port 1 *2	<ul style="list-style-type: none"> 8-bit I/O port Schmitt-triggered input (P16, P14) 	P17/PO15/TIOCB2/ TCLKD P16/PO14/TIOCA2/ IRQ1 P15/PO13/TIOCB1/ TCLKC P14/PO12/TIOCA1/ IRQ0 P13/PO11/TIOCD0/ TCLKB/A23 P12/PO10/TIOCC0/ TCLKA/A22 P11/PO9/TIOCB0/A21 P10/PO8/TIOCA0/A20	8 bit I/O port also functioning as TPU I/O pins (TCLKA, TCLKB, TCLKC, TCLKD, TIOCA0, TIOCB0, TIOCC0, TIOCD0, TIOCA1, TIOCB1, TIOCA2, TIOCB2), PPG output pins (PO15 to PO8), interrupt input pins (IRQ0, IRQ1), and address outputs (A20 to A23)			8-bit I/O port also functioning as TPU I/O pins (TCLKA, TCLKB, TCLKC, TCLKD, TIOCA0, TIOCB0, TIOCC0, TIOCD0, TIOCA1, TIOCB1, TIOCA2, TIOCB2), PPG output pins (PO15 to PO8), interrupt input pins (IRQ0, IRQ1)
Port 3	<ul style="list-style-type: none"> 6-bit I/O port Open-drain output capability Schmitt-triggered input (P35, P32) 	P35/SCK1/SCL0*1/ IRQ5 P34/RxD1/SDA0*1 P33/TxD1/SCL1*1 P32/SCK0/SDA1*1/ IRQ4 P31/RxD0 P30/TxD0	6-bit I/O port also functioning as SCI (channel 0, 1) I/O pins (TxD0, RxD0, SCK0, TxD1, RxD1, SCK1), interrupt input pins (IRQ4, IRQ5), IIC (channel 0, 1) I/O pins (SCL0, SDA0, SCL1, SDA1)*1			
Port 4 *3	<ul style="list-style-type: none"> 8-bit input port 	P47/AN7/DA1 P46/AN6/DA0 P45/AN5 P44/AN4 P43/AN3 P42/AN2 P41/AN1 P40/AN0	8-bit input port also functioning as A/D converter analog inputs (AN7 to AN0) and D/A converter analog outputs (DA1, DA0)			

Port	Description	Pins	Mode 4	Mode 5	Mode 6	Mode 7
Port 9	<ul style="list-style-type: none"> 4-bit input port 	P93/AN11 P92/AN10 P91/AN9 P90/AN8	4-bit input port also functioning as A/D converter analog inputs (AN11 to AN8)			
Port A	<ul style="list-style-type: none"> 4-bit I/O port On-chip MOS input pull-up Open-drain output capability 	PA3/A19/SCK2 PA2/A18/RxD2 PA1/A17/TxD2 PA0/A16	4-bit I/O port also functioning as SCI (channel 2) I/O pins (TxD2, RxD2, SCK2) and address outputs (A19 to A16)			4-bit I/O port also functioning as SCI (channel 2) I/O pins (TxD2, RxD2, SCK2)
Port B	<ul style="list-style-type: none"> 8-bit I/O port On-chip MOS input pull-up Open-drain output capability 	PB7/A15/TIOCB5 PB6/A14/TIOCA5 PB5/A13/TIOCB4 PB4/A12/TIOCA4 PB3/A11/TIOCD3 PB2/A10/TIOCC3 PB1/A9/TIOCB3 PB0/A8/TIOCA3	8-bit I/O port also functioning as TPU I/O pins (TIOCB5, TIOCA5, TIOCB4, TIOCA4, TIOCD3, TIOCC3, TIOCB3, TIOCA3) and address outputs (A15 to A8)			8-bit I/O port also functioning as TPU I/O pins (TIOCB5, TIOCA5, TIOCB4, TIOCA4, TIOCD3, TIOCC3, TIOCB3, TIOCA3)
Port C	<ul style="list-style-type: none"> 8-bit I/O port On-chip MOS input pull-up Open-drain output capability 	PC7/A7 PC6/A6 PC5/A5 PC4/A4 PC3/A3 PC2/A2 PC1/A1 PC0/A0	8-bit I/O port also functioning as address outputs (A7 to A0)			I/O port
Port D	<ul style="list-style-type: none"> 8-bit I/O port On-chip MOS input pull-up 	PD7/D15 PD6/D14 PD5/D13 PD4/D12 PD3/D11 PD2/D10 PD1/D9 PD0/D8	Data bus input/output			I/O port

Port	Description	Pins	Mode 4	Mode 5	Mode 6	Mode 7
Port E	<ul style="list-style-type: none"> 8-bit I/O port On-chip MOS input pull-up 	PE7/D7 PE6/D6 PE5/D5 PE4/D4 PE3/D3 PE2/D2 PE1/D1 PE0/D0	In 8-bit-bus mode: I/O port In 16-bit-bus mode: data bus input/output			I/O port
Port F	<ul style="list-style-type: none"> 6-bit I/O port Schmitt-triggered input (PF3, PF0) 	PF7/ ϕ	When DDR = 0: input port When DDR = 1 (after reset): ϕ output			When DDR = 0 (after reset): input port When DDR = 1: ϕ output
		PF6/ \overline{AS} PF5/ \overline{RD} PF4/ \overline{HWR} PF3/ $\overline{LWR}/\overline{ADTRG}/\overline{IRQ3}$	\overline{RD} , \overline{HWR} , \overline{LWR} outputs \overline{ADTRG} , $\overline{IRQ3}$ input			I/O port \overline{ADTRG} , $\overline{IRQ3}$ input
		PF0/ $\overline{IRQ2}$	$\overline{IRQ2}$ input, I/O port			
Port H	8-bit I/O port	PH7/PWM1H PH6/PWM1G PH5/PWM1F PH4/PWM1E PH3/PWM1D PH2/PWM1C PH1/PWM1B PH0/PWM1A	Function as both Motor Control PWM Timer output pins and 8-bit I/O port.			
Port J	8-bit I/O port	PJ7/PWM2H PJ6/PWM2G PJ5/PWM2F PJ4/PWM2E PJ3/PWM2D PJ2/PWM2C PJ1/PWM2B PJ0/PWM2A	Function as both Motor Control PWM Timer output pins and 8-bit I/O port.			

Notes: 1. Pins for I²C bus interface.

I²C bus interface is available as an option in the H8S/2638, H8S/2639, and H8S/2630.

2. The PPG output is not implemented in the H8S/2635 Group.

3. The DA output is not implemented in the H8S/2635 Group.

9.2 Port 1

Note: The PPG output is not implemented in the H8S/2635 Group.

9.2.1 Overview

Port 1 is an 8-bit I/O port. Port 1 pins also function as PPG output pins (PO15 to PO8), TPU I/O pins (TCLKA, TCLKB, TCLKC, TCLKD, TIOCA0, TIOCB0, TIOCC0, TIOCD0, TIOCA1, TIOCB1, TIOCA2, and TIOCB2), external interrupt pins ($\overline{\text{IRQ0}}$ and $\overline{\text{IRQ1}}$), and address bus output pins (A23 to A20). Port 1 pin functions change according to the operating mode.

Figure 9-1 shows the port 1 pin configuration.

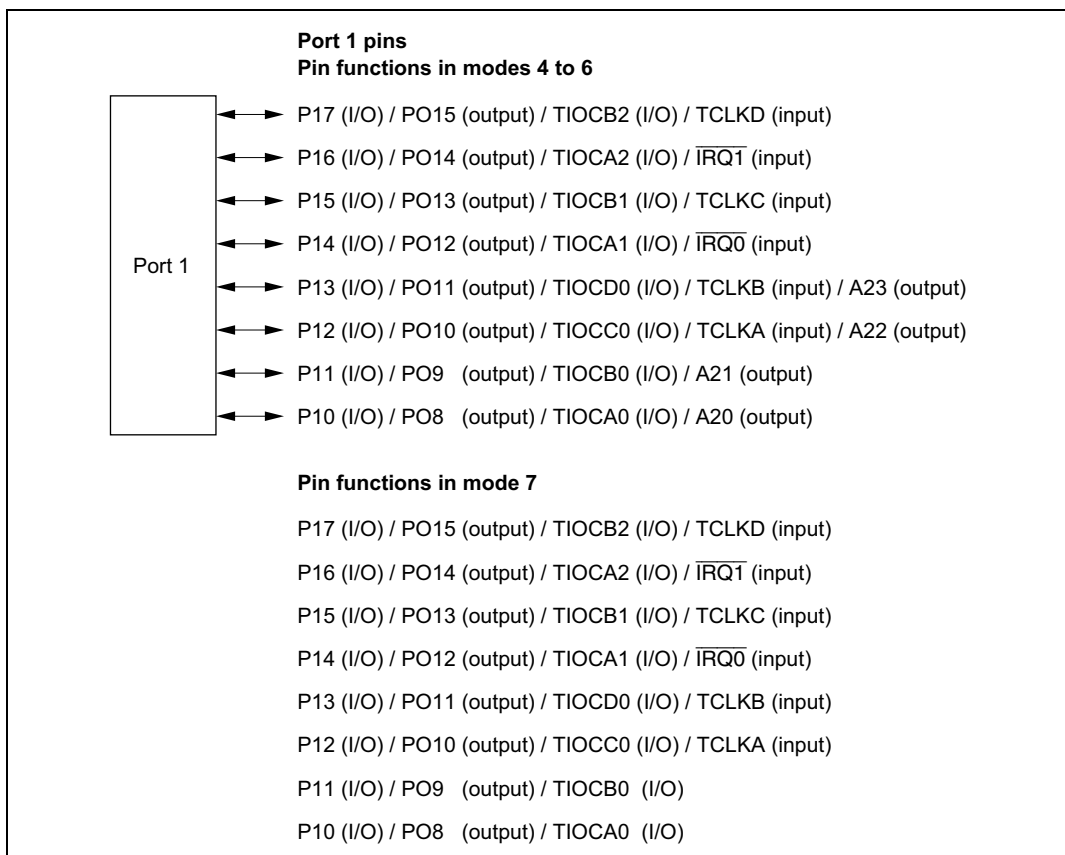

Figure 9-1 Port 1 Pin Functions

9.2.2 Register Configuration

Table 9-2 shows the port 1 register configuration.

Table 9-2 Port 1 Registers

Name	Abbreviation	R/W	Initial Value	Address*
Port 1 data direction register	P1DDR	W	H'00	H'FE30
Port 1 data register	P1DR	R/W	H'00	H'FF00
Port 1 register	PORT1	R	Undefined	H'FFB0

Note: * Lower 16 bits of the address.

Port 1 Data Direction Register (P1DDR)

Bit	:	7	6	5	4	3	2	1	0
		P17DDR	P16DDR	P15DDR	P14DDR	P13DDR	P12DDR	P11DDR	P10DDR
Initial value :		0	0	0	0	0	0	0	0
R/W	:	W	W	W	W	W	W	W	W

P1DDR is an 8-bit write-only register, the individual bits of which specify input or output for the pins of port 1. P1DDR cannot be read; if it is, an undefined value will be read.

Setting a P1DDR bit to 1 makes the corresponding port 1 pin an output pin, while clearing the bit to 0 makes the pin an input pin.

P1DDR is initialized to H'00 by a reset, and in hardware standby mode. It retains its prior state in software standby mode.

Port 1 Data Register (P1DR)

Bit	:	7	6	5	4	3	2	1	0
		P17DR	P16DR	P15DR	P14DR	P13DR	P12DR	P11DR	P10DR
Initial value :		0	0	0	0	0	0	0	0
R/W	:	R/W	R/W	R/W	R/W	R/W	R/W	R/W	R/W

P1DR is an 8-bit readable/writable register that stores output data for the port 1 pins (P17 to P10).

P1DR is initialized to H'00 by a reset, and in hardware standby mode. It retains its prior state in software standby mode.

Port 1 Register (PORT1)

Bit	:	7	6	5	4	3	2	1	0
		P17	P16	P15	P14	P13	P12	P11	P10
Initial value :		—*	—*	—*	—*	—*	—*	—*	—*
R/W	:	R	R	R	R	R	R	R	R

Note: * Determined by state of pins P17 to P10.

PORT1 is an 8-bit read-only register that shows the pin states. It cannot be written to. Writing of output data for the port 1 pins (P17 to P10) must always be performed on P1DR.

If a port 1 read is performed while P1DDR bits are set to 1, the P1DR values are read. If a port 1 read is performed while P1DDR bits are cleared to 0, the pin states are read.

After a reset and in hardware standby mode, PORT1 contents are determined by the pin states, as P1DDR and P1DR are initialized. PORT1 retains its prior state in software standby mode.

9.2.3 Pin Functions

Port 1 pins also function as PPG output pins (PO15 to PO8), TPU I/O pins (TCLKA, TCLKB, TCLKC, TCLKD, TIOCA0, TIOCB0, TIOCC0, TIOCD0, TIOCA1, TIOCB1, TIOCA2, and TIOCB2), external interrupt input pins ($\overline{IRQ0}$ and $\overline{IRQ1}$), and address bus output pins (A23 to A20). Port 1 pin functions are shown in table 9-3.

Note: The PPG output is not implemented in the H8S/2635 Group.

Table 9-3 Port 1 Pin Functions**Pin Selection Method and Pin Functions**

P17/PO15/
TIOCB2/
TCLKD

The pin function is switched as shown below according to the combination of the TPU channel 2 setting (by bits MD3 to MD0 in TMDR2, bits IOB3 to IOB0 in TIOR2, and bits CCLR1 and CCLR0 in TCR2), bits TPSC2 to TPSC0 in TCR0 and TCR5, bit NDER15 in NDERH, and bit P17DDR.

TPU Channel 2 Setting	Table Below (1)	Table Below (2)		
P17DDR	—	0	1	1
NDER15	—	—	0	1
Pin function	TIOCB2 output	P17 input	P17 output	PO15 output
		TIOCB2 input ^{*1}		
	TCLKD input ^{*2}			

- Notes: 1. TIOCB2 input when MD3 to MD0 = B'0000 or B'01xx, and IOB3 = 1.
 2. TCLKD input when the setting for either TCR0 or TCR5 is: TPSC2 to TPSC0 = B'111.
 TCLKD input when channels 2 and 4 are set to phase counting mode.

TPU Channel 2 Setting	(2)	(1)	(2)	(2)	(1)	(2)
MD3 to MD0	B'0000, B'01xx		B'0010	B'0011		
IOB3 to IOB0	B'0000 B'0100 B'1xxx	B'0001 to B'0011 B'0101 to B'0111	—	B'xx00	Other than B'xx00	
CCLR1, CCLR0	—	—	—	—	Other than B'10	B'10
Output function	—	Output compare output	—	—	PWM mode 2 output	—

x: Don't care

Pin Selection Method and Pin Functions

P16/PO14/
TIOCA2/
 $\overline{\text{IRQ1}}$

The pin function is switched as shown below according to the combination of the TPU channel 2 setting (by bits MD3 to MD0 in TMDR2, bits IOA3 to IOA0 in TIOR2, and bits CCLR1 and CCLR0 in TCR2), bit NDER14 in NDERH, and bit P16DDR.

TPU Channel 2 Setting	Table Below (1)	Table Below (2)		
P16DDR	—	0	1	1
NDER14	—	—	0	1
Pin function	TIOCA2 output	P16 input	P16 output	PO14 output
		TIOCA2 input ^{*1}		
	$\overline{\text{IRQ1}}$ input			

TPU Channel 2 Setting	(2)	(1)	(2)	(1)	(1)	(2)
MD3 to MD0	B'0000, B'01xx		B'001x	B'0010	B'0011	
IOA3 to IOA0	B'0000 B'0100 B'1xxx	B'0001 to B'0011 B'0101 to B'0111	B'xx00	Other than B'xx00		
CCLR1, CCLR0	—	—	—	—	Other than B'01	B'01
Output function	—	Output compare output	—	PWM mode 1 output ^{*2}	PWM mode 2 output	—

x: Don't care

- Notes: 1. TIOCA2 input when MD3 to MD0 = B'0000 or B'01xx, and IOA3 = 1.
2. TIOCB2 output is disabled.

Pin Selection Method and Pin Functions

P15/PO13/
TIOCB1/TCLKC

The pin function is switched as shown below according to the combination of the TPU channel 1 setting (by bits MD3 to MD0 in TMDR1, bits IOB3 to IOB0 in TIOR1, and bits CCLR1 and CCLR0 in TCR1), bits TPSC2 to TPSC0 in TCR0, TCR2, TCR4, and TCR5, bit NDER13 in NDERH, and bit P15DDR.

TPU Channel 1 Setting	Table Below (1)	Table Below (2)		
P15DDR	—	0	1	1
NDER13	—	—	0	1
Pin function	TIOCB1 output	P15 input	P15 output	PO13 output
		TIOCB1 input *1		
	TCLKC input *2			

- Notes: 1. TIOCB1 input when MD3 to MD0 = B'0000 or B'01xx, and IOB3 to IOB0 = B'10xx.
2. TCLKC input when the setting for either TCR0 or TCR2 is: TPSC2 to TPSC0 = B'110; or when the setting for either TCR4 or TCR5 is TPSC2 to TPSC0 = B'101.
TCLKC input when channels 2 and 4 are set to phase counting mode.

TPU Channel 1 Setting	(2)	(1)	(2)	(2)	(1)	(2)
MD3 to MD0	B'0000, B'01xx		B'0010	B'0011		
IOB3 to IOB0	B'0000 B'0100 B'1xxx	B'0001 to B'0011 B'0101 to B'0111	—	B'xx00	Other than B'xx00	
CCLR1, CCLR0	—	—	—	—	Other than B'10	B'10
Output function	—	Output compare output	—	—	PWM mode 2 output	—

x: Don't care

Pin Selection Method and Pin Functions

P14/PO12/
TIOCA1/ $\overline{\text{IRQ0}}$

The pin function is switched as shown below according to the combination of the TPU channel 1 setting (by bits MD3 to MD0 in TMDR1, bits IOA3 to IOA0 in TIOR1, and bits CCLR1 and CCLR0 in TCR1), bit NDER12 in NDERH, and bit P14DDR.

TPU Channel 1 Setting	Table Below (1)	Table Below (2)		
P14DDR	—	0	1	1
NDER12	—	—	0	1
Pin function	TIOCA1 output	P14 input	P14 output	PO12 output
		TIOCA1 input ^{*1}		
$\overline{\text{IRQ0}}$ input				

TPU Channel 1 Setting	(2)	(1)	(2)	(1)	(1)	(2)
MD3 to MD0	B'0000, B'01xx		B'001x	B'0010	B'0011	
IOA3 to IOA0	B'0000 B'0100 B'1xxx	B'0001 to B'0011 B'0101 to B'0111	B'xx00	Other than B'xx00		
CCLR1, CCLR0	—	—	—	—	Other than B'01	B'01
Output function	—	Output compare output	—	PWM mode 1 output ^{*2}	PWM mode 2 output	—

x: Don't care

- Notes: 1. TIOCA1 input when MD3 to MD0 = B'0000 or B'01xx, and IOA3 to IOA0 = B'10xx.
2. TIOCB1 output is disabled.

Pin Selection Method and Pin Functions

P13/PO11/
TIOCD0/TCLKB/
A23

The pin function is switched as shown below according to the combination of the operating mode, and the TPU channel 0 setting (by bits MD3 to MD0 in TMDR0, bits IOD3 to IOD0 in TIOR0L, and bits CCLR2 to CCLR0 in TCR0), bits TPSC2 to TPSC0 in TCR0 to TCR2, bits AE3 to AE0 in PFCR, bit NDER11 in NDERH, and bit P13DDR.

Operating mode	Modes 4 to 6				
AE3 to AE0	B'0000 to B'1110				B'1111
TPU Channel 0 Setting	Table Below (1)	Table Below (2)			—
P13DDR	—	0	1	1	—
NDER11	—	—	0	1	—
Pin function	TIOCD0 output	P13 input	P13 output	PO11 output	A23 output
		TIOCD0 input *1			
	TCLKB input *2				

Operating mode	Mode 7				
AE3 to AE0	—				
TPU Channel 0 Setting	Table Below (1)	Table Below (2)			—
P13DDR	—	0	1	1	—
NDER11	—	—	0	1	—
Pin function	TIOCD0 output	P13 input	P13 output	PO11 output	—
		TIOCD0 input *1			
	TCLKB input *2				

- Notes: 1. TIOCD0 input when MD3 to MD0 = B'0000, and IOD3 to IOD0 = B'10xx.
2. TCLKB input when the setting for TCR0 to TCR2 is: TPSC2 to TPSC0 = B'101.
TCLKB input when channels 1 and 5 are set to phase counting mode.

Pin Selection Method and Pin Functions

 P13/PO11/
 TIOCD0/TCLKB/
 A23

TPU Channel 0 Setting	(2)	(1)	(2)	(2)	(1)	(2)
MD3 to MD0	B'0000		B'0010	B'0011		
IOD3 to IOD0	B'0000 B'0100 B'1xxx	B'0001 to B'0011 B'0101 to B'0111	—	B'xx00	Other than B'xx00	
CCLR2 to CCLR0	—	—	—	—	Other than B'110	B'110
Output function	—	Output compare output	—	—	PWM mode 2 output	—

x: Don't care

Pin Selection Method and Pin Functions

P12/PO10/
TIOCC0/TCLKA/
A22

The pin function is switched as shown below according to the combination of the operating mode, and the TPU channel 0 setting (by bits MD3 to MD0 in TMDR0, bits IOC3 to IOC0 in TIOR0L, and bits CCLR2 to CCLR0 in TCR0), bits TPSC2 to TPSC0 in TCR0 to TCR5, bits AE3 to AE0 in PFCR, bit NDER10 in NDERH, and bit P12DDR.

Operating mode	Modes 4 to 6				
AE3 to AE0	B'0000 to B'1110				B'1111
TPU Channel 0 Setting	Table Below (1)	Table Below (2)			—
P12DDR	—	0	1	1	—
NDER10	—	—	0	1	—
Pin function	TIOCC0 output	P12 input	P12 output	PO10 output	A22 output
		TIOCC0 input ^{*1}			
	TCLKA input ^{*2}				

Operating mode	Mode 7				
AE3 to AE0	—				
TPU Channel 0 Setting	Table Below (1)	Table Below (2)			
P12DDR	—	0	1	1	
NDER10	—	—	0	1	
Pin function	TIOCC0 output	P12 input	P12 output	PO10 output	
		TIOCC0 input ^{*1}			
	TCLKA input ^{*2}				

Pin Selection Method and Pin Functions

P12/PO10/
TIOCC0/TCLKA/
A22

TPU Channel 0 Setting	(2)	(1)	(2)	(1)	(1)	(2)
MD3 to MD0	B'0000		B'001x	B'0010	B'0011	
IOC3 to IOC0	B'0000 B'0100 B'1xxx	B'0001 to B'0011 B'0101 to B'0111	B'xx00	Other than B'xx00		
CCLR2 to CCLR0	—	—	—	—	Other than B'101	B'101
Output function	—	Output compare output	—	PWM mode 1 output*3	PWM mode 2 output	—

x: Don't care

- Notes:
1. TIOCC0 input when MD3 to MD0 = B'0000, and IOC3 to IOC0 = B'10xx.
 2. TCLKA input when the setting for TCR0 to TCR5 is: TPSC2 to TPSC0 = B'100.
TCLKA input when channels 1 and 5 are set to phase counting mode.
 3. TIOCD0 output is disabled.
When BFA = 1 or BFB = 1 in TMDR0, output is disabled and setting (2) applies.
-

Pin Selection Method and Pin Functions

P11/PO9/TIOCB0/A21 The pin function is switched as shown below according to the combination of the operating mode, and the TPU channel 0 setting (by bits MD3 to MD0 in TMDR0, and bits IOB3 to IOB0 in TIOR0H), bits AE3 to AE0 in PFCR, bit NDER9 in NDERH, and bit P11DDR.

Operating mode	Modes 4 to 6				
AE3 to AE0	B'0000 to B'1101				B'1110 to B'1111
TPU Channel 0 Setting	Table Below (1)	Table Below (2)			—
P11DDR	—	0	1	1	—
NDER9	—	—	0	1	—
Pin function	TIOCB0 output	P11 input	P11 output	PO9 output	A21 output
		TIOCB0 input *			

Operating mode	Mode 7				
AE3 to AE0	—				
TPU Channel 0 Setting	Table Below (1)	Table Below (2)			
P11DDR	—	0	1	1	
NDER9	—	—	0	1	
Pin function	TIOCB0 output	P11 input	P11 output	PO9 output	
		TIOCB0 input *			

Note: * TIOCB0 input when MD3 to MD0 = B'0000, and IOB3 to IOB0 = B'10xx.

Pin Selection Method and Pin Functions

P11/PO9/TIOCB0/ A21	TPU Channel 0 Setting	(2)	(1)	(2)	(2)	(1)	(2)
	MD3 to MD0	B'0000		B'0010	B'0011		
	IOB3 to IOB0	B'0000 B'0100 B'1xxx	B'0001 to B'0011 B'0101 to B'0111	—	B'xx00	Other than B'xx00	
	CCLR2 to CCLR0	—	—	—	—	Other than B'010	B'010
	Output function	—	Output compare output	—	—	PWM mode 2 output	—

x: Don't care

Pin Selection Method and Pin Functions

P10/PO8/TIOCA0/A20 The pin function is switched as shown below according to the combination of the operating mode, and the TPU channel 0 setting (by bits MD3 to MD0 in TMDR0, bits IOA3 to IOA0 in TIOR0H, and bits CCLR2 to CCLR0 in TCRO), bits AE3 to AE0 in PFCR, bit NDER8 in NDERH, SAE0 bit in DMABCRH, and bit P10DDR.

Operating mode	Modes 4 to 6				
AE3 to AE0	B'0000 to B'1110				B'1101 to B'1111
TPU Channel 0 Setting	Table Below (1)	Table Below (2)			—
P10DDR	—	0	1	1	—
NDER8	—	—	0	1	—
Pin function	TIOCA0 output	P10 input	P10 output	PO8 output	A20 output
		TIOCA0 input *1			

Operating mode	Mode 7				
AE3 to AE0	—				
TPU Channel 0 Setting	Table Below (1)	Table Below (2)			—
P10DDR	—	0	1	1	—
NDER8	—	—	0	1	—
Pin function	TIOCA0 output	P10 input	P10 output	PO8 output	A20 output
		TIOCA0 input *1			

Pin Selection Method and Pin Functions

P10/PO8/TIOCA0/ A20	TPU Channel 0 Setting	(2)	(1)	(2)	(1)	(1)	(2)
	MD3 to MD0	B'0000		B'001x	B'0010	B'0011	
	IOA3 to IOA0	B'0000 B'0100 B'1xxx	B'0001 to B'0011 B'0101 to B'0111	B'xx00	Other than B'xx00		
	CCLR2 to CCLR0	—	—	—	—	Other than B'001	B'001
	Output function	—	Output compare output	—	PWM mode 1 output*2	PWM mode 2 output	—

x: Don't care

- Notes: 1. TIOCA0 input when MD3 to MD0 = B'0000, and IOA3 to IOA0 = B'10xx.
2. TIOCB0 output is disabled.
-

9.3 Port 3

9.3.1 Overview

Port 3 is an 6-bit I/O port. Port 3 is a multi-purpose port for SCI I/O pins (TxD0, RxD0, SCK0, TxD1, RxD1, SCK1), external interrupt input pins ($\overline{\text{IRQ4}}$, $\overline{\text{IRQ5}}$), and IIC I/O pins* (SCL0, SDA0, SCL1, SDA1). All of the port 3 pin functions have the same operating mode. The configuration for each of the port 3 pins is shown in figure. 9-2.

Note: * Available when using I²C bus interface as an option in the H8S/2638, H8S/2639, and H8S/2630 (the product equipped with the I²C bus interface is the W-mask version).

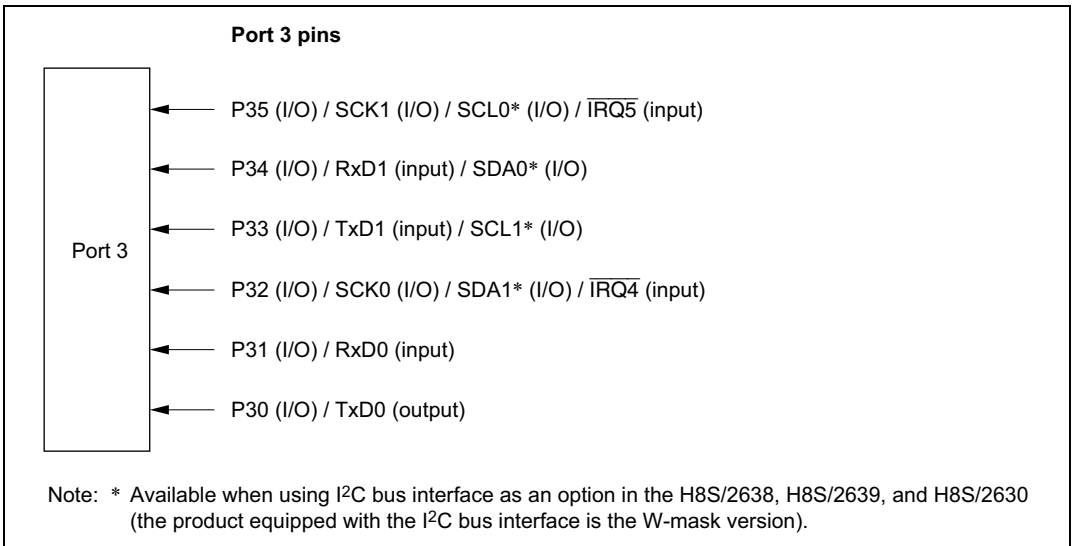

Figure 9-2 Port 3 Pin Functions

9.3.2 Register Configuration

Table 9-4 shows the configuration of port 3 registers.

Table 9-4 Port 3 Register Configuration

Name	Abbreviation	R/W	Initial Value* ²	Address* ¹
Port 3 data direction register	P3DDR	W	B'***000000	H'FE32
Port 3 data register	P3DR	R/W	B'***000000	H'FF02
Port 3 register	PORT3	R	Undefined	H'FFB2
Port 3 open drain control register	P3ODR	R/W	B'***000000	H'FE46

Notes: 1. Lower 16 bits of the address.

2. Value of bits 5 to 0.

Port 3 Data Direction Register (P3DDR)

Bit	7	6	5	4	3	2	1	0
	—	—	P35DDR	P34DDR	P33DDR	P32DDR	P31DDR	P30DDR
Initial value	Undefined	Undefined	0	0	0	0	0	0
Read/Write	—	—	W	W	W	W	W	W

P3DDR is an 8-bit write-dedicated register, which specifies the I/O for each port 3 pin by bit. Read is disabled. If a read is carried out, undefined values are read out.

By setting P3DDR to 1, the corresponding port 3 pins become output, and by clearing to 0 they become input.

P3DDR is initialized to B'***000000 by a reset and in hardware standby mode. The previous state is maintained in software standby mode. The pin state is determined by specifying SCI, IIC*, P3DDR, and P3DR.

Note: * Available when using I²C bus interface as an option in the H8S/2638, H8S/2639, and H8S/2630 (the product equipped with the I²C bus interface is the W-mask version).

Port 3 Data Register (P3DR)

Bit	7	6	5	4	3	2	1	0
	—	—	P35DR	P34DR	P33DR	P32DR	P31DR	P30DR
Initial value	Undefined	Undefined	0	0	0	0	0	0
Read/Write	—	—	R/W	R/W	R/W	R/W	R/W	R/W

P3DR is an 8-bit readable/writable register, which stores the output data of port 3 pins (P35 to P30).

P3DR is initialized to B^{*}000000 by a reset and in hardware standby mode. The previous state is maintained in software standby mode.

Port 3 Register (PORT3)

Bit	7	6	5	4	3	2	1	0
	—	—	P35	P34	P33	P32	P31	P30
Initial value	Undefined	Undefined	—*	—*	—*	—*	—*	—*
Read/Write	—	—	R	R	R	R	R	R

Note: * Determined by the state of pins P35 to P30.

PORT3 is an 8-bit read-dedicated register, which reflects the state of pins. Write is disabled. Always carry out writing off output data of port 3 pins (P35 to P30) to P3DR without fail.

When P3DDR is set to 1, if port 3 is read, the values of P3DR are read. When P3DDR is cleared to 0, if port 3 is read, the states of pins are read out.

P3DDR and P3DR are initialized by a reset and in hardware standby mode, so PORT3 is determined by the state of the pins. The previous state is maintained in software standby mode.

Port 3 Open Drain Control Register (P3ODR)

Bit	7	6	5	4	3	2	1	0
	—	—	P35ODR	P34ODR	P33ODR	P32ODR	P31ODR	P30ODR
Initial value	Undefined	Undefined	0	0	0	0	0	0
Read/Write	—	—	R/W	R/W	R/W	R/W	R/W	R/W

P3ODR is an 8-bit readable/writable register, which controls the on/off of port 3 pins (P35 to P30).

By setting P3ODR to 1, the port 3 pins become an open drain out, and when cleared to 0 they become CMOS output.

P3ODR is initialized to B^{***}000000 by a reset and in hardware standby mode. The previous state is maintained in software standby mode.

9.3.3 Pin Functions

The port 3 pins double as SCI I/O input pins (TxD0, RxD0, SCK0, TxD1, RxD1, and SCK1) external interrupt input pins ($\overline{\text{IRQ}}4$ and $\overline{\text{IRQ}}5$), and IIC I/O pins* (SCL0, SDA0, SCL1, and SDA1). The functions of port 3 pins are shown in table 9-5.

Note: * Available when using I²C bus interface as an option in the H8S/2638, H8S/2639, and H8S/2630 (the product equipped with the I²C bus interface is the W-mask version).

Table 9-5 Port 3 Pin Functions**Pin Selection Method and Pin Functions**

P35/SCK1/
SCL0*¹/IRQ5 Switches as follows according to combinations of ICCR0 ICE bit*¹ of IIC0, bit C/ \bar{A} of SMR1, bits CKE0 and CKE1 of SCR1, and bit P35DDR.

When used as a SCL0 I/O pin, always be sure to clear the following bits to 0: bit C/ \bar{A} of SMR1, and bits CKE0 and CKE1 of SCR1. The SCL0 output format is NMOS open drain output, enabling direct bus driving.

ICE* ¹	0					1
CKE1	0			1	—	0
C/ \bar{A}	0		1	—	—	0
CKE0	0	1	—	—	—	0
P35DDR	0	1	—	—	—	—
Pin function	P35 input	P35 output*	SCK1 output*	SCK1 output*	SCK1 input	SCL0 I/O
	IRQ5 input					

Note: * When P35ODR = 1, it becomes NMOS open drain output.

In W mask-ROM versions, the output format is NMOS push-pull. However, it becomes NMOS open drain output when P35ODR = 1.

P34/RxD1/
SDA0*¹ Switches as follows according to combinations of ICCR0 ICE bit*¹ of IIC0, bit RE of SCR1 and bit P34DDR. The SDA0 output format is NMOS open drain output, enabling direct bus driving.

ICE* ¹	0			1
RE	0		1	—
P34DDR	0	1	—	—
Pin function	P34 input	P34 output*	RxD1 input	SDA0 I/O

Note: * When P34ODR = 1, it becomes NMOS open drain output.

In W mask-ROM versions, the output format is NMOS push-pull. However, it becomes NMOS open drain output when P34ODR = 1.

Pin Selection Method and Pin Functions

**P33/TxD1/
SCL1*¹** Switches as follows according to combinations of ICCR1 ICE bit*¹ of IIC1, bit TE of SCR1 and bit P33DDR. The SCL1 output format is NMOS open drain output, enabling direct bus driving.

ICE* ¹	0			1
TE	0		1	—
P33DDR	0	1	—	—
Pin function	P33 input	P33 output*	TxD1 output*	SCL1 I/O

Note: * When P33ODR = 1, it becomes NMOS open drain output.

**P32/SCK0/
SDA1*¹/IRQ4** Switches as follows according to combinations of ICCR1 ICE bit*¹ of IIC1, bit C/A of SMR0, bits CKE0 and CKE1 of SCR0, and bit P32DDR. When used as a SDA1 I/O pin, always be sure to clear the following bits to 0: SMR0 C/A bit, SCR0 CKE0 and CKE1 bits.

The SDA1 output format is NMOS open drain output, enabling direct bus driving.

ICE* ¹	0				1	
CKE1	0			1	0	
C/A	0		1	—	0	
CKE0	0	1	—	—	0	
P32DDR	0	1	—	—	—	
Pin function	P32 input	P32 output	SCK0 output*	SCK0 output*	SCK0 input	SDA1 I/O
	IRQ4 input					

Note: * When P32ODR = 1, it becomes NMOS open drain output.

**P31/RxD0/
IrRxD** Switches as follows according to combinations of bit RE of SCR0 and bit P31DDR.

RE	0		1
P31DDR	0	1	—
Pin function	P31 input	P31 output*	RxD0 input

Note: * When P31ODR = 1, it becomes NMOS open drain output.

**P30/TxD0/
IrTxD** Switches as follows according to combinations of bit TE of SCR0 and bit P30DDR.

TE	0		1
P30DDR	0	1	—
Pin function	P30 input	P30 output*	TxD0 output*

Note: * When P30ODR = 1, it becomes NMOS open drain output.

Note: 1. Available when using I²C bus interface (the W-mask version of the H8S/2638, H8S/2639, and H8S/2630 only). In W mask-ROM versions, the output format is NMOS push-pull. However, it becomes NMOS open drain output when P34ODR = 1 and P35ODR = 1.

9.4 Port 4

Note: The DA output is not implemented in the H8S/2635 Group.

9.4.1 Overview

Port 4 is an 8-bit input-only port. Port 4 pins also function as A/D converter analog input pins (AN0 to AN7) and D/A converter analog output pins (DA0, DA1). Port 4 pin functions are the same in all operating modes. Figure 9-3 shows the port 4 pin configuration.

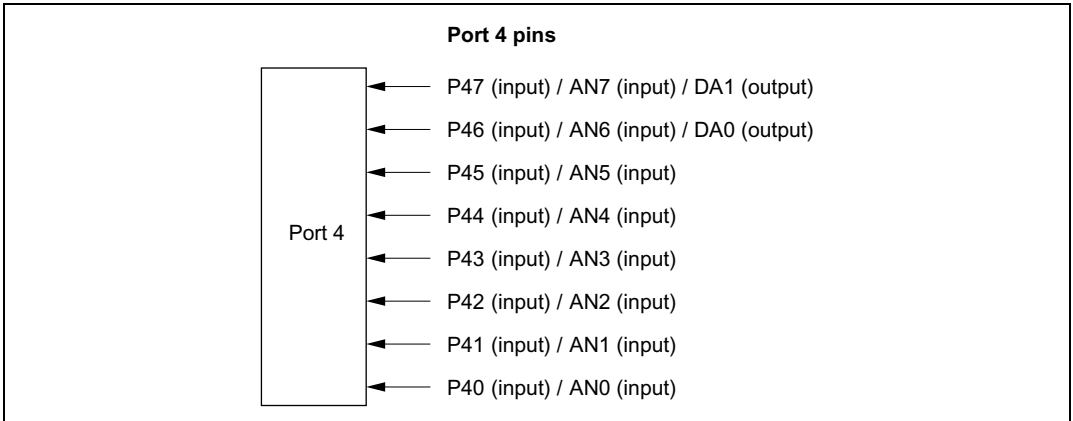

Figure 9-3 Port 4 Pin Functions

9.4.2 Register Configuration

Table 9-6 shows the port 4 register configuration. Port 4 is an input-only port, and does not have a data direction register or data register.

Table 9-6 Port 4 Registers

Name	Abbreviation	R/W	Initial Value	Address*
Port 4 register	PORT4	R	Undefined	H'FFB3

Note: * Lower 16 bits of the address.

Port 4 Register (PORT4): The pin states are always read when a port 4 read is performed.

Bit	:	7	6	5	4	3	2	1	0								
		<table border="1" style="width: 100%; text-align: center;"> <tr> <td>P47</td> <td>P46</td> <td>P45</td> <td>P44</td> <td>P43</td> <td>P42</td> <td>P41</td> <td>P40</td> </tr> </table>								P47	P46	P45	P44	P43	P42	P41	P40
P47	P46	P45	P44	P43	P42	P41	P40										
Initial value :		__*	__*	__*	__*	__*	__*	__*	__*								
R/W	:	R	R	R	R	R	R	R	R								

Note: * Determined by state of pins P47 to P40.

9.4.3 Pin Functions

Port 4 pins also function as A/D converter analog input pins (AN0 to AN7) and D/A converter analog output pins (DA0 and DA1).

9.5 Port 9

9.5.1 Overview

Port 9 is a 4-bit input-only port. Port 9 pins also function as A/D converter analog input pins (AN8 to AN11). Port 9 pin functions are the same in all operating modes. Figure 9-4 shows the port 9 pin configuration.

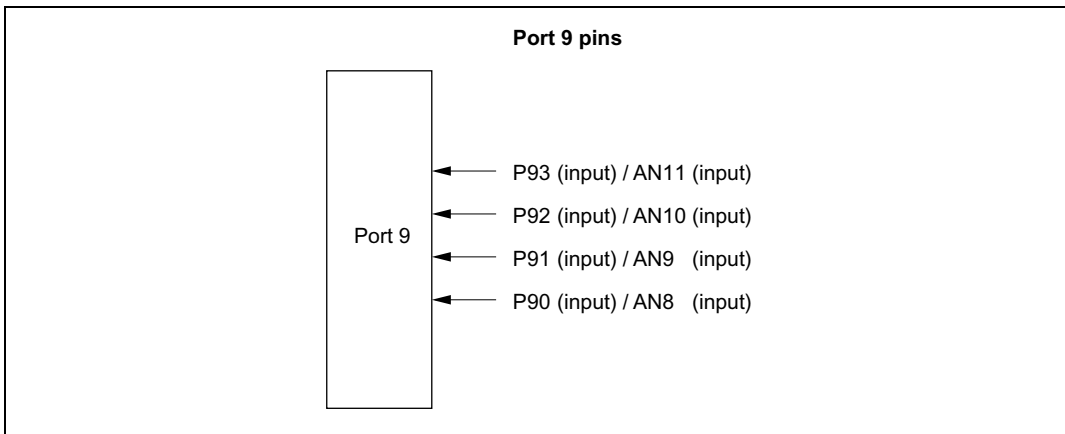

Figure 9-4 Port 9 Pin Functions

9.5.2 Register Configuration

Table 9-7 shows the port 9 register configuration. Port 9 is an input-only port, and does not have a data direction register or data register.

Table 9-7 Port 9 Registers

Name	Abbreviation	R/W	Initial Value	Address*
Port 9 register	PORT9	R	Undefined	H'FFB8

Note: * Lower 16 bits of the address.

Port 9 Register (PORT9): The pin states are always read when a port 9 read is performed.

Bit	:	7	6	5	4	3	2	1	0
		—	—	—	—	P93	P92	P91	P90
Initial value :		—*	—*	—*	—*	—*	—*	—*	—*
R/W	:	—	—	—	—	R	R	R	R

Note: * Determined by state of pins P93 to P90.

9.5.3 Pin Functions

Port 9 pins also function as A/D converter analog input pins (AN8 to AN11) are multipurpose pins which function as A/D converter analog input pins (AN8 to AN11).

9.6 Port A

9.6.1 Overview

Port A is a 4-bit I/O port. Port A pins also function as address bus outputs and SCI2 I/O pins (SCK2, RxD2, and TxD2). The pin functions change according to the operating mode.

Port A has an on-chip MOS input pull-up function that can be controlled by software.

Figure 9-5 shows the port A pin configuration.

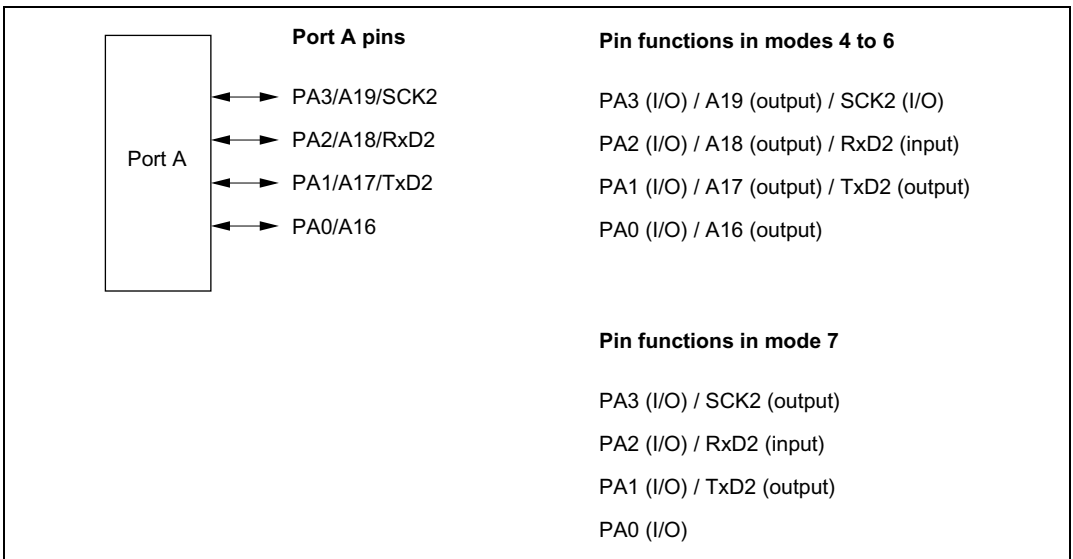

Figure 9-5 Port A Pin Functions

9.6.2 Register Configuration

Table 9-8 shows the port A register configuration.

Table 9-8 Port A Registers

Name	Abbreviation	R/W	Initial Value* ²	Address* ¹
Port A data direction register	PADDR	W	H'0	H'FE39
Port A data register	PADR	R/W	H'0	H'FF09
Port A register	PORTA	R	Undefined	H'FFB9
Port A MOS pull-up control register	PAPCR	R/W	H'0	H'FF40
Port A open-drain control register	PAODR	R/W	H'0	H'FF47

Notes: 1. Lower 16 bits of the address.
2. Value of bits 3 to 0.

Port A Data Direction Register (PADDR)

Bit	:	7	6	5	4	3	2	1	0
		—	—	—	—	PA3DDR	PA2DDR	PA1DDR	PA0DDR
Initial value	:	Undefined	Undefined	Undefined	Undefined	0	0	0	0
R/W	:	—	—	—	—	W	W	W	W

PADDR is an 8-bit write-only register, the individual bits of which specify input or output for the pins of port A. PADDR cannot be read; if it is, an undefined value will be read.

Bits 7 to 4 are reserved; they return an undetermined value if read.

PADDR is initialized to H'0 (bits 3 to 0) by a reset, and in hardware standby mode. It retains its prior state in software standby mode. The OPE bit in SBYCR is used to select whether the address output pins retain their output state or become high-impedance when a transition is made to software standby mode.

- Modes 4 to 6

The corresponding port A pins become address outputs in accordance with the setting of bits AE3 to AE0 in PFCR, irrespective of the value of bits PA3DDR to PA0DDR. When pins are not used as address outputs, setting a PADDR bit to 1 makes the corresponding port A pin an output port, while clearing the bit to 0 makes the pin an input port.

- Mode 7

Setting a PADDR bit to 1 makes the corresponding port A pin an output port, while clearing the bit to 0 makes the pin an input port.

Port A Data Register (PADR)

Bit	:	7	6	5	4	3	2	1	0
		—	—	—	—	PA3DR	PA2DR	PA1DR	PA0DR
Initial value	:	Undefined	Undefined	Undefined	Undefined	0	0	0	0
R/W	:	—	—	—	—	R/W	R/W	R/W	R/W

PADR is an 8-bit readable/writable register that stores output data for the port A pins (PA3 to PA0).

Bits 7 to 4 are reserved; they return an undetermined value if read, and cannot be modified.

PADR is initialized to H'0 (bits 3 to 0) by a reset, and in hardware standby mode. It retains its prior state in software standby mode.

Port A Register (PORTA)

Bit	:	7	6	5	4	3	2	1	0
		—	—	—	—	PA3	PA2	PA1	PA0
Initial value	:	Undefined	Undefined	Undefined	Undefined	—*	—*	—*	—*
R/W	:	—	—	—	—	R	R	R	R

Note: * Determined by state of pins PA3 to PA0.

PORTA is an 8-bit read-only register that shows the pin states. It cannot be written to. Writing of output data for the port A pins (PA3 to PA0) must always be performed on PADR.

Bits 7 to 4 are reserved; they return an undetermined value if read, and cannot be modified.

If a port A read is performed while PADDR bits are set to 1, the PADR values are read. If a port A read is performed while PADDR bits are cleared to 0, the pin states are read.

After a reset and in hardware standby mode, PORTA contents are determined by the pin states, as PADDR and PADR are initialized. PORTA retains its prior state in software standby mode.

Port A MOS Pull-Up Control Register (PAPCR)

Bit	:	7	6	5	4	3	2	1	0
		—	—	—	—	PA3PCR	PA2PCR	PA1PCR	PA0PCR
Initial value	:	Undefined	Undefined	Undefined	Undefined	0	0	0	0
R/W	:	—	—	—	—	R/W	R/W	R/W	R/W

PAPCR is an 8-bit readable/writable register that controls the MOS input pull-up function incorporated into port A on an individual bit basis.

Bits 7 to 4 are reserved; they return an undetermined value if read, and cannot be modified. In modes 4 to 6, if a pin is in the input state in accordance with the settings in PFCR, in the SCI's SCMR, SMR, and SCR, and in DDR, setting the corresponding PAPCR bit to 1 turns on the MOS input pull-up for that pin.

In mode 7, if a pin is in the input state in accordance with the settings in the SCI's SCMR, SMR, and SCR, and in DDR, setting the corresponding PAPCR bit to 1 turns on the MOS input pull-up for that pin.

PAPCR is initialized by a reset or to H'0 (bits 3 to 0), and in hardware standby mode. It retains its prior state in software standby mode.

Port A Open Drain Control Register (PAODR)

Bit	:	7	6	5	4	3	2	1	0
		—	—	—	—	PA3ODR	PA2ODR	PA1ODR	PA0ODR
Initial value	:	Undefined	Undefined	Undefined	Undefined	0	0	0	0
R/W	:	—	—	—	—	R/W	R/W	R/W	R/W

PAODR is an 8-bit readable/writable register that controls whether PMOS is on or off for each port A pin (PA3 to PA0).

Bits 7 to 4 are reserved; they return an undetermined value if read, and cannot be modified.

When pins are not address outputs in accordance with the setting of bits AE3 to AE0 in PFCR, setting a PAODR bit makes the corresponding port A pin an NMOS open-drain output, while clearing the bit to 0 makes the pin a CMOS output.

PAODR is initialized to H'0 (bits 3 to 0) by a reset, and in hardware standby mode. It retains its prior state in software standby mode.

9.6.3 Pin Functions

Port A pins also function as SCI input/output pins (TxD2, RxD2, SCK2) and address bus output pins (A19 to A16). Port A pin functions are shown in table 9-9.

Table 9-9 Port A Pin Functions

Pin	Selection Method and Pin Functions					
PA3/A19/SCK2	The pin function is switched as shown below according to the operating mode, bits AE3 to AE0 in PFCR, bit C/A in SMR and bits CKE0 and CKE1 in SCR of SCI2, and bit PA3DDR.					
Operating mode	Modes 4 to 6					
AE3 to AE0	B'0000 to B'1011					B'1100 to B'1111
CKE1	0			1		—
C/A	0		1	—	—	
CKE0	0		1	—	—	—
PA3DDR	0	1	—	—	—	—
Pin function	PA3 input	PA3 output	SCK2 output	SCK2 output	SCK2 input	A19 output
Operating mode	Mode 7					
CKE1	0					1
C/A	0			1		—
CKE0	0		1		—	—
PA3DDR	0	1	—	—	—	
Pin function	PA3 input	PA3 output	SCK2 output	SCK2 output	SCK2 input	

Pin Selection Method and Pin Functions

PA2/A18/RxD2 The pin function is switched as shown below according to the operating mode, bits AE3 to AE0 in PFCR, bit RE in SCR of SCI2, and bit PA2DDR.

Operating mode	Modes 4 to 6			
AE3 to AE0	B'0000 to B'1011			B'1011 to B'1111
RE	0		1	—
PA2DDR	0	1	—	—
Pin function	PA2 input	PA2 output	RxD2 input	A18 output

Operating mode	Mode 7		
RE	0		1
PA2DDR	0	1	—
Pin function	PA2 input	PA2 output	RxD2 input

PA1/A17/TxD2 The pin function is switched as shown below according to the operating mode, bits AE3 to AE0 in PFCR, bit TE in SCR of SCI2, and bit PA1DDR.

Operating mode	Modes 4 to 6			
AE3 to AE0	B'0000 to B'1001			B'1010 to B'1111
TE	0		1	—
PA1DDR	0	1	—	—
Pin function	PA1 input	PA1 output	TxD2 output	A17 output

Operating mode	Mode 7		
TE	0		1
PA1DDR	0	1	—
Pin function	PA1 input	PA1 output	TxD2 output

Pin Selection Method and Pin Functions

PA0/A16 The pin function is switched as shown below according to the operating mode, bits AE3 to AE0 in PFCCR, and bit PA0DDR.

Operating mode	Modes 4 to 6		
AE3 to AE0	B'0000 to B'1000		B'1001 to B'1111
PA0DDR	0	1	—
Pin function	PA0 input	PA0 output	A16 output

Operating mode	Mode 7	
PA0DDR	0	1
Pin function	PA0 input	PA0 output

9.6.4 Pin Functions

Modes 4 to 6: In modes 4 to 6, port A pins function as address outputs according to the setting of AE3 to AE0 in PFCCR; when they do not function as address outputs, the pins function as SCI I/O pins and I/O ports.

Port A pin functions in modes 4 to 6 are shown in figure 9-6.

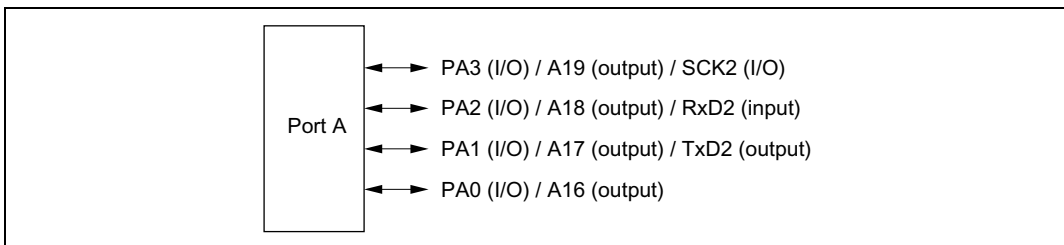

Figure 9-6 Port A Pin Functions (Modes 4 to 6)

Mode 7: In mode 7, port A pins function as I/O ports and SCI2 I/O pins (SCK2, TxD2, RxD2). Input or output can be specified for each pin on an individual bit basis. Setting a PADDDR bit to 1 makes the corresponding port A pin an output port, while clearing the bit to 0 makes the pin an input port.

Port A pin functions are shown in figure 9-7.

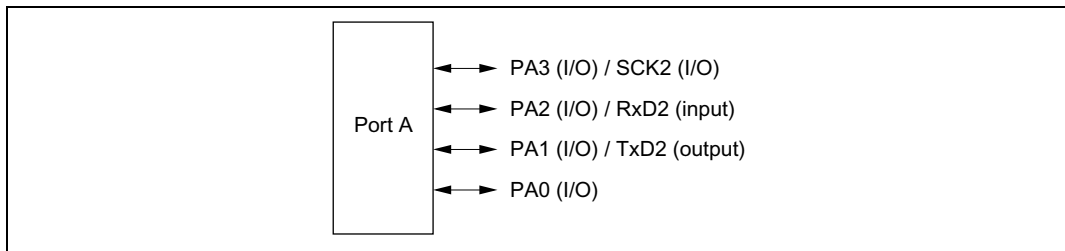

Figure 9-7 Port A Pin Functions (Mode 7)

9.6.5 MOS Input Pull-Up Function

Port A has an on-chip MOS input pull-up function that can be controlled by software. MOS input pull-up can be specified as on or off on an individual bit basis.

In modes 4 to 6, if a pin is in the input state in accordance with the settings in PFCR, in the SCI's SCMR, SMR, and SCR, and in DDR, setting the corresponding PAPCR bit to 1 turns on the MOS input pull-up for that pin.

In mode 7, if a pin is in the input state in accordance with the settings in the SCI's SCMR, SMR, and SCR, and in DDR, setting the corresponding PAPCR bit to 1 turns on the MOS input pull-up for that pin.

The MOS input pull-up function is in the off state after a reset, and in hardware standby mode. The prior state is retained in software standby mode.

Table 9-10 summarizes the MOS input pull-up states.

Table 9-10 MOS Input Pull-Up States (Port A)

Pin States	Reset	Hardware Standby Mode	Software Standby Mode	In Other Operations
Address output or SCI output	OFF	OFF	OFF	OFF
Other than above			ON/OFF	ON/OFF

Legend:

OFF: MOS input pull-up is always off.

ON/OFF: On when PADDR = 0 and PAPCR = 1; otherwise off.

9.7 Port B

9.7.1 Overview

Port B is an 8-bit I/O port. Port B pins also function as TPU I/O pins (TIOCA3, TIOCB3, TIOCC3, TIOCD3, TIOCA4, TIOCB4, TIOCA5, TIOCB5) and as address outputs; the pin functions change according to the operating mode.

Port B has an on-chip MOS input pull-up function that can be controlled by software.

Figure 9-8 shows the port B pin configuration.

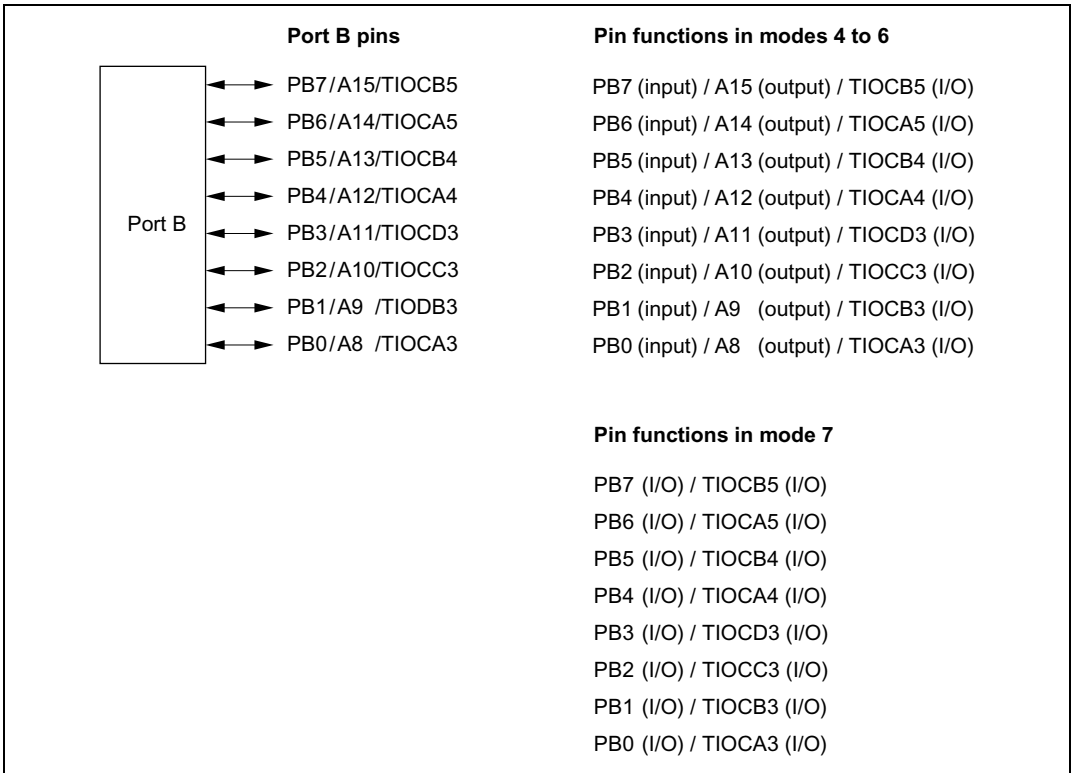

Figure 9-8 Port B Pin Functions

9.7.2 Register Configuration

Table 9-11 shows the port B register configuration.

Table 9-11 Port B Registers

Name	Abbreviation	R/W	Initial Value	Address*
Port B data direction register	PBDDR	W	H'00	H'FE3A
Port B data register	PBDR	R/W	H'00	H'FF0A
Port B register	PORTB	R	Undefined	H'FFBA
Port B MOS pull-up control register	PBPCR	R/W	H'00	H'FF41
Port B open-drain control register	PBODR	R/W	H'00	H'FE48

Note: * Lower 16 bits of the address.

Port B Data Direction Register (PBDDR)

Bit	:	7	6	5	4	3	2	1	0
		PB7DDR	PB6DDR	PB5DDR	PB4DDR	PB3DDR	PB2DDR	PB1DDR	PB0DDR
Initial value :		0	0	0	0	0	0	0	0
R/W	:	W	W	W	W	W	W	W	W

PBDDR is an 8-bit write-only register, the individual bits of which specify input or output for the pins of port B. PBDDR cannot be read; if it is, an undefined value will be read.

PBDDR is initialized to H'00 by a reset, and in hardware standby mode. It retains its prior state in software standby mode. The OPE bit in SBYCR is used to select whether the address output pins retain their output state or become high-impedance when a transition is made to software standby mode.

- Modes 4 to 6

The corresponding port B pins become address outputs in accordance with the setting of bits AE3 to AE0 in PFCR, irrespective of the value of the PBDDR bits. When pins are not used as address outputs, setting a PBDDR bit to 1 makes the corresponding port B pin an output port, while clearing the bit to 0 makes the pin an input port.

- Mode 7

Setting a PBDDR bit to 1 makes the corresponding port B pin an output port, while clearing the bit to 0 makes the pin an input port.

Port B Data Register (PBDR)

Bit	:	7	6	5	4	3	2	1	0
		PB7DR	PB6DR	PB5DR	PB4DR	PB3DR	PB2DR	PB1DR	PB0DR
Initial value :		0	0	0	0	0	0	0	0
R/W	:	R/W	R/W	R/W	R/W	R/W	R/W	R/W	R/W

PBDR is an 8-bit readable/writable register that stores output data for the port B pins (PB7 to PB0). PBDR is initialized to H'00 by a reset, and in hardware standby mode. It retains its prior state in software standby mode.

Port B Register (PORTB)

Bit	:	7	6	5	4	3	2	1	0
		PB7	PB6	PB5	PB4	PB3	PB2	PB1	PB0
Initial value :		—*	—*	—*	—*	—*	—*	—*	—*
R/W	:	R	R	R	R	R	R	R	R

Note: * Determined by state of pins PB7 to PB0.

PORTB is an 8-bit read-only register that shows the pin states. It cannot be written to. Writing of output data for the port B pins (PB7 to PB0) must always be performed on PBDR.

If a port B read is performed while PBDDR bits are set to 1, the PBDR values are read. If a port B read is performed while PBDDR bits are cleared to 0, the pin states are read.

After a reset and in hardware standby mode, PORTB contents are determined by the pin states, as PBDDR and PBDR are initialized. PORTB retains its prior state in software standby mode.

Port B MOS Pull-Up Control Register (PBPCR)

Bit	:	7	6	5	4	3	2	1	0
		PB7PCR	PB6PCR	PB5PCR	PB4PCR	PB3PCR	PB2PCR	PB1PCR	PB0PCR
Initial value :		0	0	0	0	0	0	0	0
R/W	:	R/W	R/W	R/W	R/W	R/W	R/W	R/W	R/W

PBPCR is an 8-bit readable/writable register that controls the MOS input pull-up function incorporated into port B on an individual bit basis.

In modes 4 to 6, if a pin is in the input state in accordance with the settings in PFCR, in the TPU's TIOR, and in DDR, setting the corresponding PBPCR bit to 1 turns on the MOS input pull-up for that pin.

In mode 7, if a pin is in the input state in accordance with the settings in the TPU's TIOR and in DDR, setting the corresponding PBPCR bit to 1 turns on the MOS input pull-up for that pin.

PBPCR is initialized to H'00 by a reset, and in hardware standby mode. It retains its prior state in software standby mode.

Port B Open Drain Control Register (PBODR)

Bit	:	7	6	5	4	3	2	1	0
		PB7ODR	PB6ODR	PB5ODR	PB4ODR	PB3ODR	PB2ODR	PB1ODR	PB0ODR
Initial value :		0	0	0	0	0	0	0	0
R/W	:	R/W	R/W	R/W	R/W	R/W	R/W	R/W	R/W

PBODR is an 8-bit readable/writable register that controls the PMOS on/off state for each port B pin (PB7 to PB0).

When pins are not address outputs in accordance with the setting of bits AE3 to AE0 in PFCR, setting a PBODR bit makes the corresponding port B pin an NMOS open-drain output, while clearing the bit to 0 makes the pin a CMOS output.

PBODR is initialized to H'00 by a reset, and in hardware standby mode. It retains its prior state in software standby mode.

9.7.3 Pin Functions

Modes 4 to 6: In modes 4 to 6, the corresponding port B pins become address outputs in accordance with the setting of bits AE3 to AE0 in PFCR. When pins are not used as address outputs, they function as TPU I/O pins and I/O ports.

Port B pin functions in modes 4 to 6 are shown in figure 9-9.

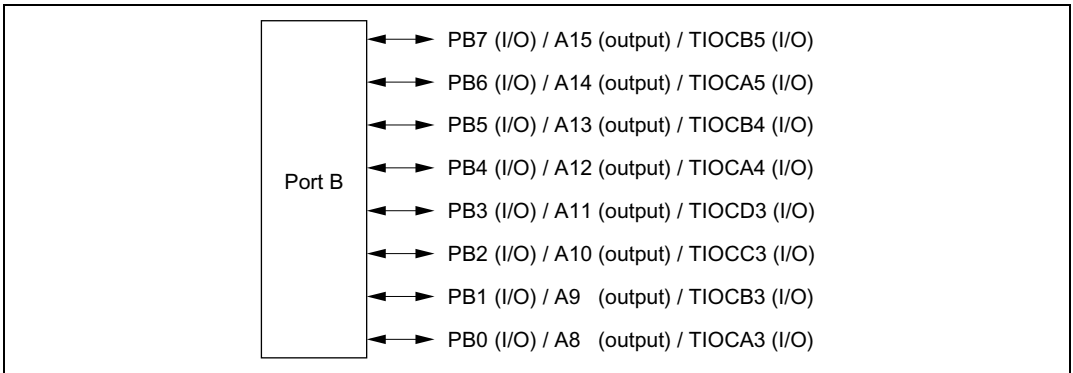

Figure 9-9 Port B Pin Functions (Modes 4 to 6)

Mode 7: In mode 7, port B pins function as I/O ports and TPU I/O pins (TIOCA3, TIOCB3, TIOCC3, TIOCD3, TIOCA4, TIOCB4, TIOCA5, and TIOCB5). Input or output can be specified for each pin on an individual bit basis. Setting a PBDDR bit to 1 makes the corresponding port B pin an output port, while clearing the bit to 0 makes the pin an input port.

Port B pin functions in mode 7 are shown in figure 9-10.

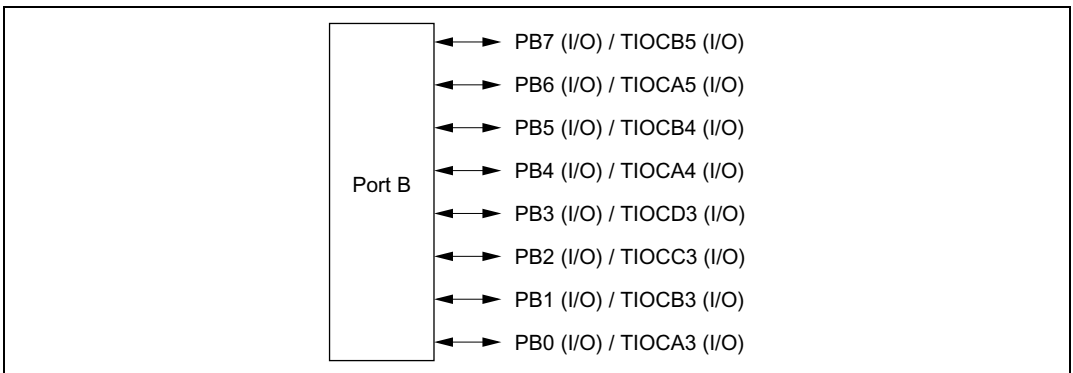

Figure 9-10 Port B Pin Functions (Mode 7)

9.7.4 MOS Input Pull-Up Function

Port B has an on-chip MOS input pull-up function that can be controlled by software. MOS input pull-up can be specified as on or off on an individual bit basis.

In modes 4 to 6, if a pin is in the input state in accordance with the settings in PFCR, in the TPU's TIOR, and in DDR, setting the corresponding PBPCR bit to 1 turns on the MOS input pull-up for that pin.

In mode 7, if a pin is in the input state in accordance with the settings in the TPU's TIOR and in DDR, setting the corresponding PBPCR bit to 1 turns on the MOS input pull-up for that pin.

The MOS input pull-up function is in the off state after a reset, and in hardware standby mode. The prior state is retained by a manual reset or in software standby mode.

Table 9-12 summarizes the MOS input pull-up states.

Table 9-12 MOS Input Pull-Up States (Port B)

Pin States	Reset	Hardware Standby Mode	Software Standby Mode	In Other Operations
Address output or TPU output	OFF	OFF	OFF	OFF
Other than above			ON/OFF	ON/OFF

Legend:

OFF: MOS input pull-up is always off.

ON/OFF: On when PBDDR = 0 and PBPCR = 1; otherwise off.

9.8 Port C

9.8.1 Overview

Port C is an 8-bit I/O port. Port C has an address bus output function. The pin functions change according to the operating mode.

Port C has an on-chip MOS input pull-up function that can be controlled by software.

Figure 9-11 shows the port C pin configuration.

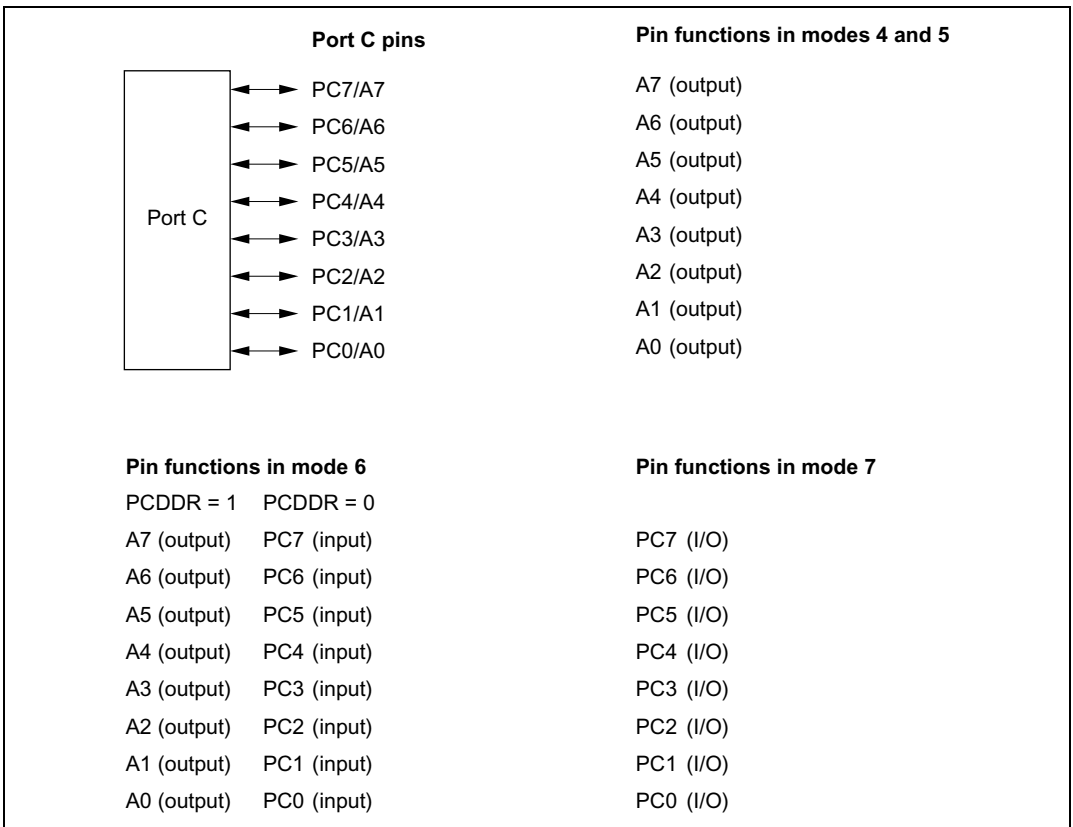

Figure 9-11 Port C Pin Functions

9.8.2 Register Configuration

Table 9-13 shows the port C register configuration.

Table 9-13 Port C Registers

Name	Abbreviation	R/W	Initial Value	Address*
Port C data direction register	PCDDR	W	H'00	H'FE3B
Port C data register	PCDR	R/W	H'00	H'FF0B
Port C register	PORTC	R	Undefined	H'FFBB
Port C MOS pull-up control register	PCPCR	R/W	H'00	H'FF42
Port C open-drain control register	PCODR	R/W	H'00	H'FE49

Note: * Lower 16 bits of the address.

Port C Data Direction Register (PCDDR)

Bit	:	7	6	5	4	3	2	1	0
		PC7DDR	PC6DDR	PC5DDR	PC4DDR	PC3DDR	PC2DDR	PC1DDR	PC0DDR
Initial value :		0	0	0	0	0	0	0	0
R/W	:	W	W	W	W	W	W	W	W

PCDDR is an 8-bit write-only register, the individual bits of which specify input or output for the pins of port C. PCDDR cannot be read; if it is, an undefined value will be read.

PCDDR is initialized to H'00 by a reset, and in hardware standby mode. It retains its prior state in software standby mode. The OPE bit in SBYCR is used to select whether the address output pins retain their output state or become high-impedance when the mode is changed to software standby mode.

- Modes 4 and 5
The corresponding port C pins are address outputs irrespective of the value of the PCDDR bits.
- Mode 6
Setting a PCDDR bit to 1 makes the corresponding port C pin an address output, while clearing the bit to 0 makes the pin an input port.
- Mode 7
Setting a PCDDR bit to 1 makes the corresponding port C pin an output port, while clearing the bit to 0 makes the pin an input port.

Port C Data Register (PCDR)

Bit	:	7	6	5	4	3	2	1	0
		PC7DR	PC6DR	PC5DR	PC4DR	PC3DR	PC2DR	PC1DR	PC0DR
Initial value :		0	0	0	0	0	0	0	0
R/W	:	R/W	R/W	R/W	R/W	R/W	R/W	R/W	R/W

PCDR is an 8-bit readable/writable register that stores output data for the port C pins (PC7 to PC0).

PCDR is initialized to H'00 by a reset, and in hardware standby mode. It retains its prior state in software standby mode.

Port C Register (PORTC)

Bit	:	7	6	5	4	3	2	1	0
		PC7	PC6	PC5	PC4	PC3	PC2	PC1	PC0
Initial value :		—*	—*	—*	—*	—*	—*	—*	—*
R/W	:	R	R	R	R	R	R	R	R

Note: * Determined by state of pins PC7 to PC0.

PORTC is an 8-bit read-only register that shows the pin states. It cannot be written to. Writing of output data for the port C pins (PC7 to PC0) must always be performed on PCDR.

If a port C read is performed while PCDDR bits are set to 1, the PCDR values are read. If a port C read is performed while PCDDR bits are cleared to 0, the pin states are read.

After a reset and in hardware standby mode, PORTC contents are determined by the pin states, as PCDDR and PCDR are initialized. PORTC retains its prior state in software standby mode.

Port C MOS Pull-Up Control Register (PCPCR)

Bit	:	7	6	5	4	3	2	1	0
		PC7PCR	PC6PCR	PC5PCR	PC4PCR	PC3PCR	PC2PCR	PC1PCR	PC0PCR
Initial value :		0	0	0	0	0	0	0	0
R/W	:	R/W	R/W	R/W	R/W	R/W	R/W	R/W	R/W

PCPCR is an 8-bit readable/writable register that controls the MOS input pull-up function incorporated into port C on an individual bit basis.

In modes 6 and 7, if PCPCR is set to 1 when the port is in the input state in accordance with the settings of PCDDR, the MOS input pull-up is set to ON.

PCPCR is initialized to H'00 by a reset, and in hardware standby mode. It retains its prior state by a manual reset or in software standby mode.

Port C Open Drain Control Register (PCODR)

Bit		7	6	5	4	3	2	1	0
		PC7ODR	PC6ODR	PC5ODR	PC4ODR	PC3ODR	PC2ODR	PC1ODR	PC0ODR
Initial value		0	0	0	0	0	0	0	0
Read/Write		R/W	R/W	R/W	R/W	R/W	R/W	R/W	R/W

PCDDR is an 8-bit Read/Write register and controls PMOS On/Off of each pin (PC7 to PC0) of port C.

If PCODR is set to 1 by setting AE3 to AE0 in PFCR in mode other than address output mode, port C pins function as NMOS open drain outputs and when the setting is cleared to 0, the pins function as CMOS outputs.

PCODR is initialized to H'00 in reset mode or hardware standby mode. PCODR retains the last state in software standby mode.

9.8.3 Pin Functions for Each Mode

Modes 4 and 5: In modes 4 and 5, port C pins function as address outputs automatically.

Figure 9-12 shows the port C pin functions.

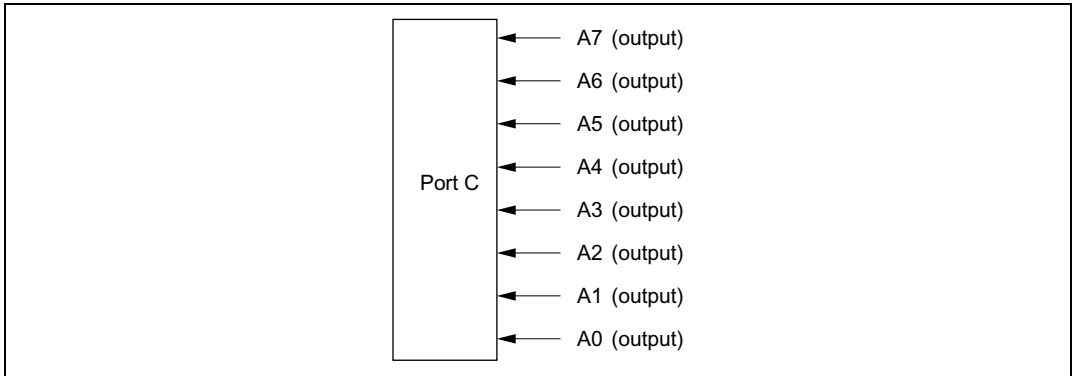

Figure 9-12 Port C Pin Functions (Modes 4 and 5)

Mode 6: In mode 6, port C pins function as address outputs or input ports and I/O can be specified in bit units. When each bit in PCDDR is set to 1, the corresponding pin functions as an address output and when the bit cleared to 0, the pin functions as an input port.

Figure 9-13 shows the port C pin functions.

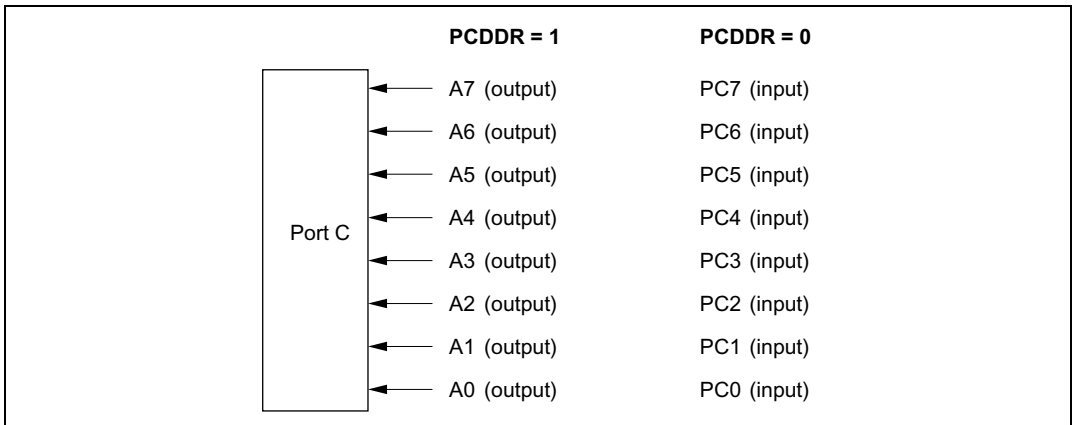

Figure 9-13 Port C Pin Functions (Mode 6)

Mode 7: In mode 7, port C pins function as I/O ports and I/O can be specified for each pin in bit units. When each bit in PCDDR is set to 1, the corresponding pin functions as an output port and when the bit is cleared to 0, the pin functions as an input port.

Figure 9-14 shows the port C pin functions.

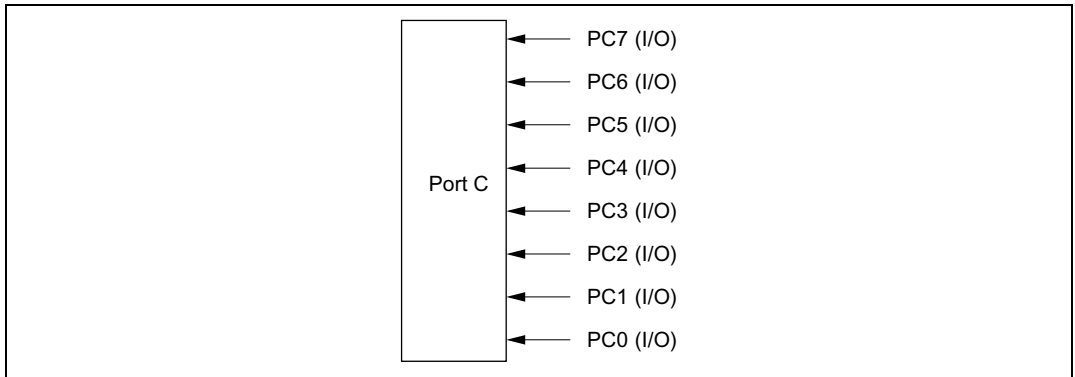

Figure 9-14 Port C Pin Functions (Mode 7)

9.8.4 MOS Input Pull-Up Function

Port C has an on-chip MOS input pull-up function that can be controlled by software. This MOS input pull-up function can be used in modes 6 and 7, and can be specified as on or off on an individual bit basis.

In modes 6 and 7, when PCPCR is set to 1 in the input state by setting of PCDDR, the MOS input pull-up is set to ON.

The MOS input pull-up function is in the off state after a reset, and in hardware standby mode. The prior state is retained by a manual reset or in software standby mode.

Table 9-14 summarizes the MOS input pull-up states.

Table 9-14 MOS Input Pull-Up States (Port C)

Pin States	Reset	Hardware Standby Mode	Software Standby Mode	In Other Operations
Address output	OFF	OFF	OFF	OFF
Other than above			ON/OFF	ON/OFF

Legend:

OFF: MOS input pull-up is always off.

ON/OFF: On when PCDDR = 0 and PCPCR = 1; otherwise off.

9.9 Port D

9.9.1 Overview

Port D is an 8-bit I/O port. Port D has a data bus I/O function, and the pin functions change according to the operating mode.

Port D has an on-chip MOS input pull-up function that can be controlled by software.

Figure 9-15 shows the port D pin configuration.

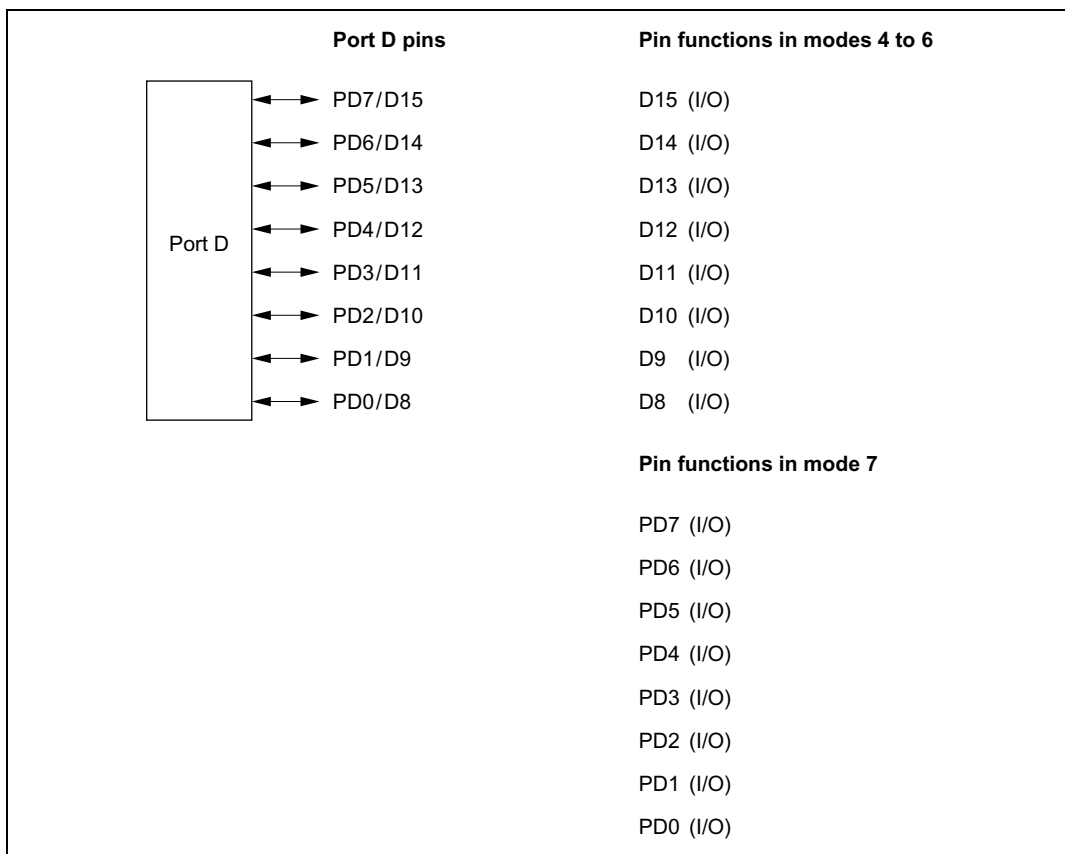

Figure 9-15 Port D Pin Functions

9.9.2 Register Configuration

Table 9-15 shows the port D register configuration.

Table 9-15 Port D Registers

Name	Abbreviation	R/W	Initial Value	Address*
Port D data direction register	PDDDR	W	H'00	H'FE3C
Port D data register	PDDR	R/W	H'00	H'FF0C
Port D register	PORTD	R	Undefined	H'FFBC
Port D MOS pull-up control register	PDPCR	R/W	H'00	H'FE43

Note: * Lower 16 bits of the address.

Port D Data Direction Register (PDDDR)

Bit	:	7	6	5	4	3	2	1	0
		PD7DDR	PD6DDR	PD5DDR	PD4DDR	PD3DDR	PD2DDR	PD1DDR	PD0DDR
Initial value :		0	0	0	0	0	0	0	0
R/W	:	W	W	W	W	W	W	W	W

PDDDR is an 8-bit write-only register, the individual bits of which specify input or output for the pins of port D. PDDDR cannot be read; if it is, an undefined value will be read.

PDDDR is initialized to H'00 by a reset, and in hardware standby mode. It retains its prior state in software standby mode.

- Modes 4 to 6

The input/output direction specification by PDDDR is ignored, and port D is automatically designated for data I/O.

- Mode 7

Setting a PDDDR bit to 1 makes the corresponding port D pin an output port, while clearing the bit to 0 makes the pin an input port.

Port D Data Register (PDDR)

Bit	:	7	6	5	4	3	2	1	0
		PD7DR	PD6DR	PD5DR	PD4DR	PD3DR	PD2DR	PD1DR	PD0DR
Initial value :		0	0	0	0	0	0	0	0
R/W	:	R/W	R/W	R/W	R/W	R/W	R/W	R/W	R/W

PDDR is an 8-bit readable/writable register that stores output data for the port D pins (PD7 to PD0).

PDDR is initialized to H'00 by a reset, and in hardware standby mode. It retains its prior state in software standby mode.

Port D Register (PORTD)

Bit	:	7	6	5	4	3	2	1	0
		PD7	PD6	PD5	PD4	PD3	PD2	PD1	PD0
Initial value :		—*	—*	—*	—*	—*	—*	—*	—*
R/W	:	R	R	R	R	R	R	R	R

Note: * Determined by state of pins PD7 to PD0.

PORTD is an 8-bit read-only register that shows the pin states. It cannot be written to. Writing of output data for the port D pins (PD7 to PD0) must always be performed on PDDR.

If a port D read is performed while PDDDR bits are set to 1, the PDDR values are read. If a port D read is performed while PDDDR bits are cleared to 0, the pin states are read.

After a reset and in hardware standby mode, PORTD contents are determined by the pin states, as PDDDR and PDDR are initialized. PORTD retains its prior state in software standby mode.

Port D MOS Pull-Up Control Register (PDPCR)

Bit	:	7	6	5	4	3	2	1	0
		PD7PCR	PD6PCR	PD5PCR	PD4PCR	PD3PCR	PD2PCR	PD1PCR	PD0PCR
Initial value :		0	0	0	0	0	0	0	0
R/W	:	R/W	R/W	R/W	R/W	R/W	R/W	R/W	R/W

PDPCR is an 8-bit readable/writable register that controls the MOS input pull-up function incorporated into port D on an individual bit basis.

When a PDDDR bit is cleared to 0 (input port setting) in mode 7, setting the corresponding PDPCR bit to 1 turns on the MOS input pull-up for the corresponding pin.

PDPCR is initialized to H'00 by a reset, and in hardware standby mode. It retains its prior state in software standby mode.

9.9.3 Pin Functions

Modes 4 to 6: In modes 4 to 6, port D pins are automatically designated as data I/O pins.

Port D pin functions in modes 4 to 6 are shown in figure 9-16.

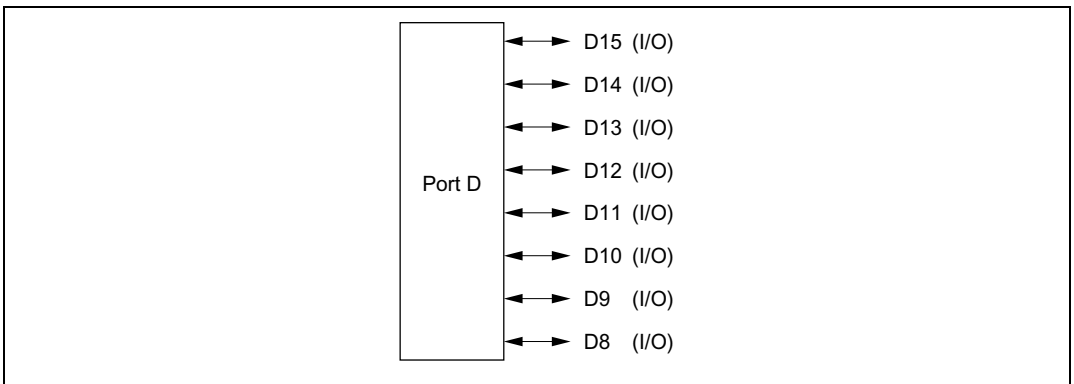

Figure 9-16 Port D Pin Functions (Modes 4 to 6)

Mode 7: In mode 7, port D pins function as I/O ports. Input or output can be specified for each pin on an individual bit basis. Setting a PDDDR bit to 1 makes the corresponding port D pin an output port, while clearing the bit to 0 makes the pin an input port.

Port D pin functions in mode 7 are shown in figure 9-17.

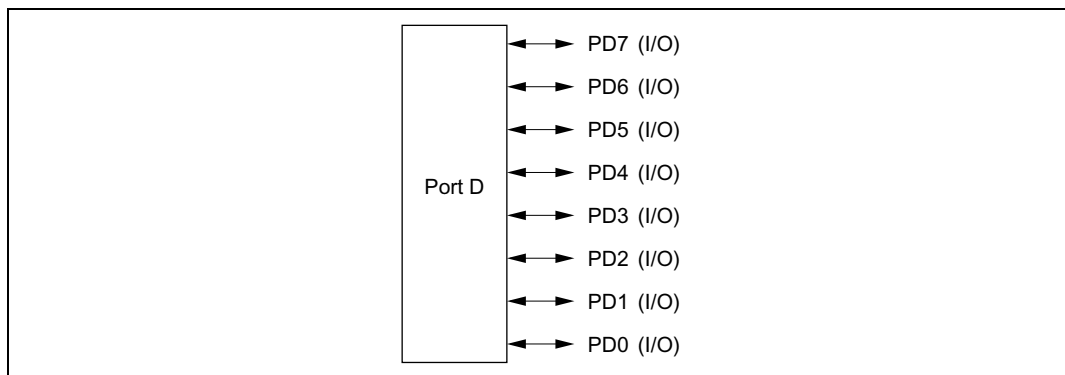

Figure 9-17 Port D Pin Functions (Mode 7)

9.9.4 MOS Input Pull-Up Function

Port D has an on-chip MOS input pull-up function that can be controlled by software. This MOS input pull-up function can be used in mode 7, and can be specified as on or off on an individual bit basis.

When a PDDDR bit is cleared to 0 in mode 7, setting the corresponding PDPCR bit to 1 turns on the MOS input pull-up for that pin.

The MOS input pull-up function is in the off state after a reset, and in hardware standby mode. The prior state is retained in software standby mode.

Table 9-16 summarizes the MOS input pull-up states.

Table 9-16 MOS Input Pull-Up States (Port D)

Modes	Reset	Hardware Standby Mode	Software Standby Mode	In Other Operations
4 to 6	OFF	OFF	OFF	OFF
7			ON/OFF	ON/OFF

Legend:

OFF: MOS input pull-up is always off.

ON/OFF: On when PDDDR = 0 and PDPCR = 1; otherwise off.

9.10 Port E

9.10.1 Overview

Port E is an 8-bit I/O port. Port E has a data bus I/O function, and the pin functions change according to the operating mode and whether 8-bit or 16-bit bus mode is selected.

Port E has an on-chip MOS input pull-up function that can be controlled by software.

Figure 9-18 shows the port E pin configuration.

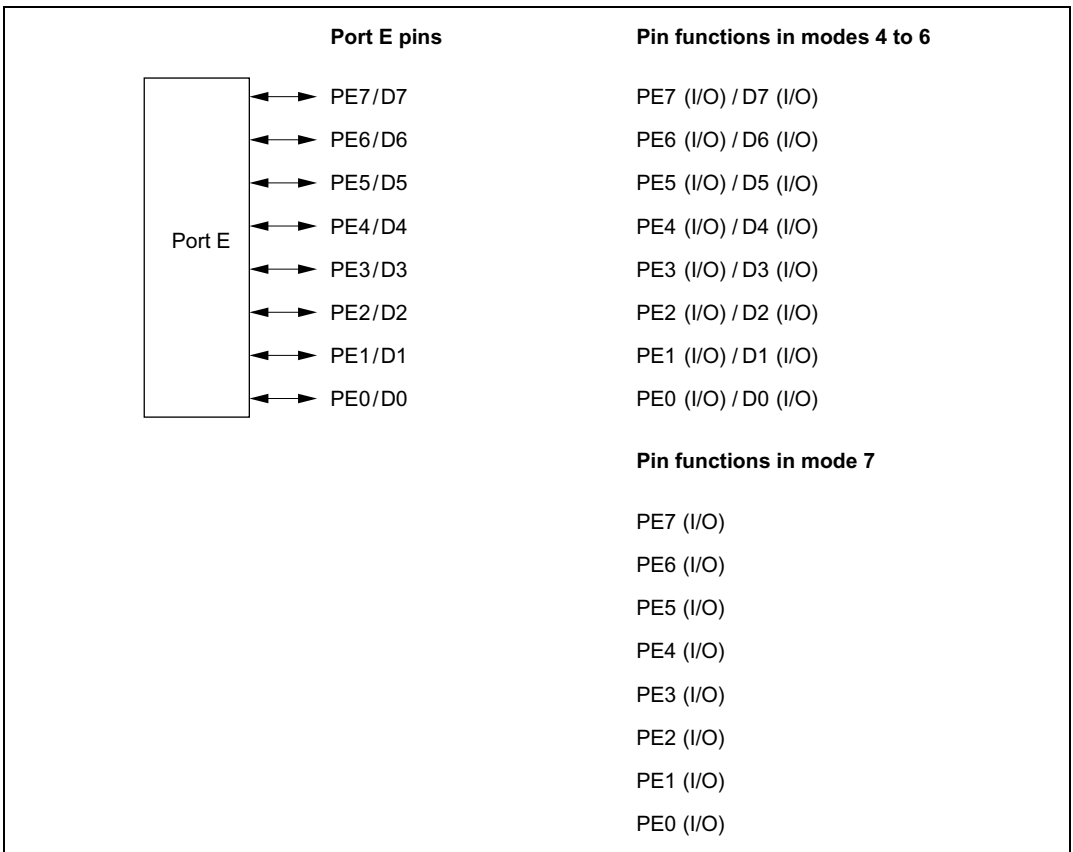

Figure 9-18 Port E Pin Functions

9.10.2 Register Configuration

Table 9-17 shows the port E register configuration.

Table 9-17 Port E Registers

Name	Abbreviation	R/W	Initial Value	Address*
Port E data direction register	PEDDR	W	H'00	H'FE3D
Port E data register	PEDR	R/W	H'00	H'FF0D
Port E register	PORTE	R	Undefined	H'FFBD
Port E MOS pull-up control register	PEPCR	R/W	H'00	H'FE44

Note: * Lower 16 bits of the address.

Port E Data Direction Register (PEDDR)

Bit	:	7	6	5	4	3	2	1	0
		PE7DDR	PE6DDR	PE5DDR	PE4DDR	PE3DDR	PE2DDR	PE1DDR	PE0DDR
Initial value :		0	0	0	0	0	0	0	0
R/W	:	W	W	W	W	W	W	W	W

PEDDR is an 8-bit write-only register, the individual bits of which specify input or output for the pins of port E. PEDDR cannot be read; if it is, an undefined value will be read.

PEDDR is initialized to H'00 by a reset, and in hardware standby mode. It retains its prior state by a manual reset or in software standby mode.

- Modes 4 to 6

When 8-bit bus mode has been selected, port E pins function as I/O ports. Setting a PEDDR bit to 1 makes the corresponding port E pin an output port, while clearing the bit to 0 makes the pin an input port.

When 16-bit bus mode has been selected, the input/output direction specification by PEDDR is ignored, and port E is designated for data I/O.

For details of 8-bit and 16-bit bus modes, see section 7, Bus Controller.

- Mode 7

Setting a PEDDR bit to 1 makes the corresponding port E pin an output port, while clearing the bit to 0 makes the pin an input port.

Port E Data Register (PEDR)

Bit	:	7	6	5	4	3	2	1	0
		PE7DR	PE6DR	PE5DR	PE4DR	PE3DR	PE2DR	PE1DR	PE0DR
Initial value :		0	0	0	0	0	0	0	0
R/W	:	R/W	R/W	R/W	R/W	R/W	R/W	R/W	R/W

PEDR is an 8-bit readable/writable register that stores output data for the port E pins (PE7 to PE0).

PEDR is initialized to H'00 by a reset, and in hardware standby mode. It retains its prior state in software standby mode.

Port E Register (PORTE)

Bit	:	7	6	5	4	3	2	1	0
		PE7	PE6	PE5	PE4	PE3	PE2	PE1	PE0
Initial value :		—*	—*	—*	—*	—*	—*	—*	—*
R/W	:	R	R	R	R	R	R	R	R

Note: * Determined by state of pins PE7 to PE0.

PORTE is an 8-bit read-only register that shows the pin states. It cannot be written to. Writing of output data for the port E pins (PE7 to PE0) must always be performed on PEDR.

If a port E read is performed while PEDDR bits are set to 1, the PEDR values are read. If a port E read is performed while PEDDR bits are cleared to 0, the pin states are read.

After a reset and in hardware standby mode, PORTE contents are determined by the pin states, as PEDDR and PEDR are initialized. PORTE retains its prior state in software standby mode.

Port E MOS Pull-Up Control Register (PEPCR)

Bit	:	7	6	5	4	3	2	1	0
		PE7PCR	PE6PCR	PE5PCR	PE4PCR	PE3PCR	PE2PCR	PE1PCR	PE0PCR
Initial value :		0	0	0	0	0	0	0	0
R/W	:	R/W	R/W	R/W	R/W	R/W	R/W	R/W	R/W

PEPCR is an 8-bit readable/writable register that controls the MOS input pull-up function incorporated into port E on an individual bit basis.

When a PEDDR bit is cleared to 0 (input port setting) with 8-bit bus mode selected in mode 4, 5, or 6, or in mode 7, setting the corresponding PEPCR bit to 1 turns on the MOS input pull-up for the corresponding pin.

PEPCR is initialized to H'00 by a reset, and in hardware standby mode. It retains its prior state in software standby mode.

9.10.3 Pin Functions

Modes 4 to 6: In modes 4 to 6, when 8-bit access is designated and 8-bit bus mode is selected, port E pins are automatically designated as I/O ports. Setting a PEDDR bit to 1 makes the corresponding port E pin an output port, while clearing the bit to 0 makes the pin an input port.

When 16-bit bus mode is selected, the input/output direction specification by PEDDR is ignored, and port E is designated for data I/O.

Port E pin functions in modes 4 to 6 are shown in figure 9-19.

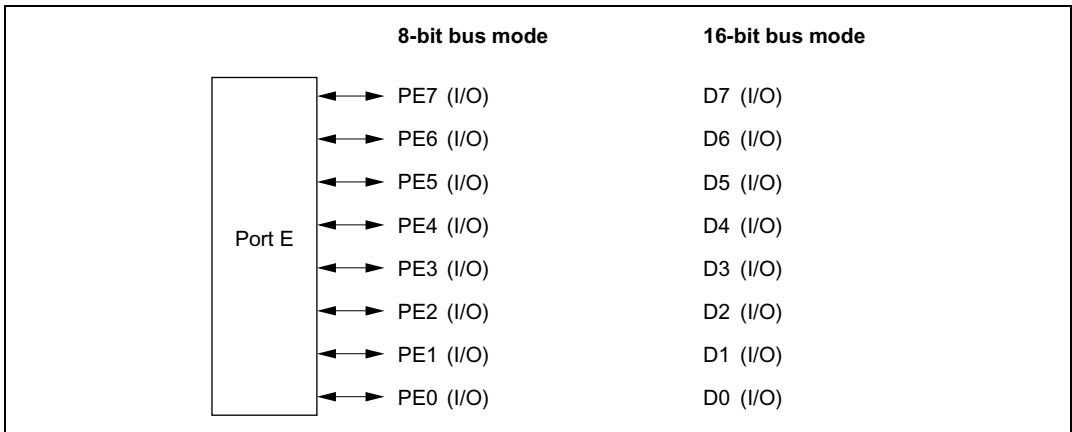

Figure 9-19 Port E Pin Functions (Modes 4 to 6)

Mode 7: In mode 7, port E pins function as I/O ports. Input or output can be specified for each pin on a bit-by-bit basis. Setting a PEDDR bit to 1 makes the corresponding port E pin an output port, while clearing the bit to 0 makes the pin an input port.

Port E pin functions in mode 7 are shown in figure 9-20.

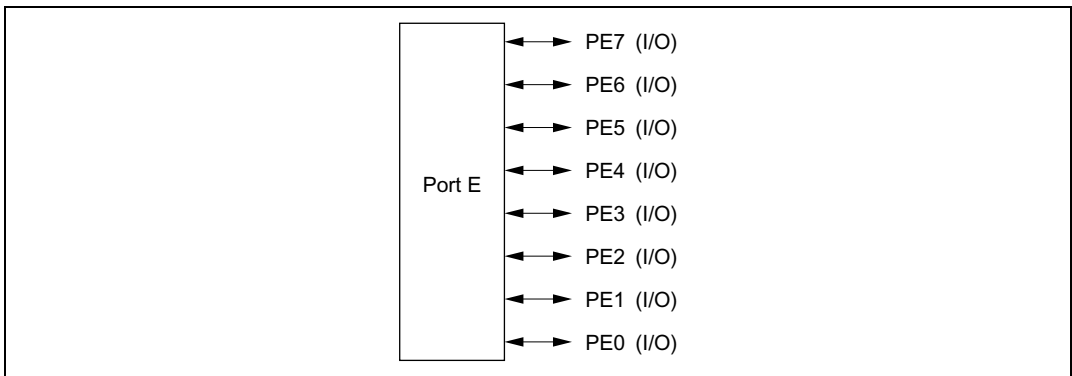

Figure 9-20 Port E Pin Functions (Mode 7)

9.10.4 MOS Input Pull-Up Function

Port E has an on-chip MOS input pull-up function that can be controlled by software. This MOS input pull-up function can be used in modes 4 to 6 when 8-bit bus mode is selected, or in mode 7, and can be specified as on or off on an individual bit basis.

When a PEDDR bit is cleared to 0 in modes 4 to 6 when 8-bit bus mode is selected, or in mode 7, setting the corresponding PEPCR bit to 1 turns on the MOS input pull-up for that pin.

The MOS input pull-up function is in the off state after a reset, and in hardware standby mode. The prior state is retained in software standby mode.

Table 9-18 summarizes the MOS input pull-up states.

Table 9-18 MOS Input Pull-Up States (Port E)

Modes	Reset	Hardware Standby Mode	Software Standby Mode	In Other Operations
7	OFF	OFF	ON/OFF	ON/OFF
4 to 6				
			8-bit bus	
			16-bit bus	OFF

Legend:

OFF: MOS input pull-up is always off.

ON/OFF: On when PEDDR = 0 and PEPCR = 1; otherwise off.

9.11 Port F

9.11.1 Overview

Port F is a 6-bit I/O port. Port F pins also function as external interrupt input pins ($\overline{\text{IRQ2}}$ and $\overline{\text{IRQ3}}$), A/D trigger input pin ($\overline{\text{ADTRG}}$), bus control signal input/output pins ($\overline{\text{AS}}$, $\overline{\text{RD}}$, $\overline{\text{HWR}}$, and $\overline{\text{LWR}}$), and the system clock (ϕ) output pin.

Figure 9-21 shows the port F pin configuration.

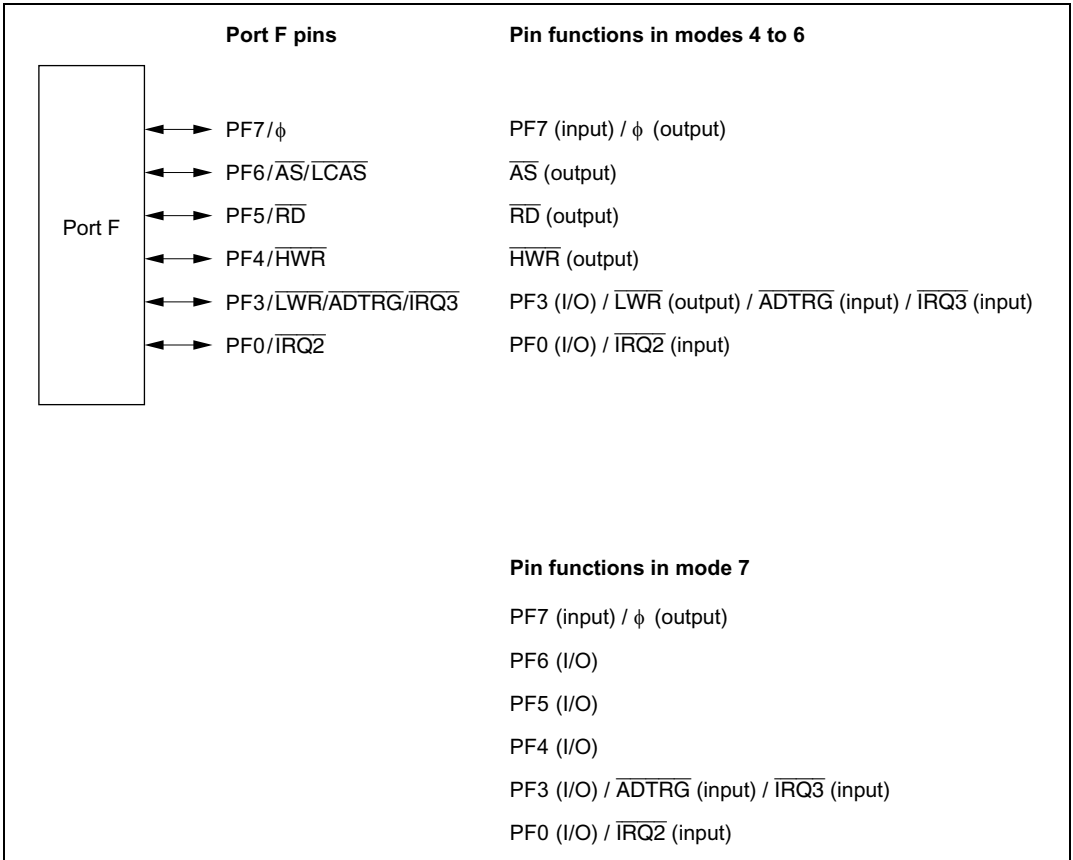

Figure 9-21 Port F Pin Functions

9.11.2 Register Configuration

Table 9-19 shows the port F register configuration.

Table 9-19 Port F Registers

Name	Abbreviation	R/W	Initial Value	Address ^{*1}
Port F data direction register	PFDDR	W	B'10000**0 ^{*2} / B'00000**0 ^{*2}	H'FE3E
Port F data register	PFDR	R/W	B'00000**0	H'FF0E
Port F register	PORTF	R	Undefined	H'FFBE

Notes: 1. Lower 16 bits of the address.
2. Initial value depends on the mode.

Port F Data Direction Register (PFDDR)

Bit	7	6	5	4	3	2	1	0
	PF7DDR	PF6DDR	PF5DDR	PF4DDR	PF3DDR	—	—	PF0DDR
Modes 4 to 6								
Initial value :	1	0	0	0	0	undefined	undefined	0
R/W :	W	W	W	W	W	—	—	W
Mode 7								
Initial value :	0	0	0	0	0	undefined	undefined	0
R/W :	W	W	W	W	W	—	—	W

PFDDR is an 8-bit write-only register, the individual bits of which specify input or output for the pins of port F. PFDDR cannot be read; if it is, an undefined value will be read.

PFDDR is initialized by a reset, and in hardware standby mode, to B'10000**0 in modes 4 to 6, and to B'00000**0 in mode 7. It retains its prior state in software standby mode. The OPE bit in SBYCR is used to select whether the bus control output pins retain their output state or become high-impedance when a transition is made to software standby mode.

- Modes 4 to 6

Pin PF7 functions as the ϕ output pin when the corresponding PFDDR bit is set to 1, and as an input port when the bit is cleared to 0.

The input/output direction specified by PFDDR is ignored for pins PF6 to PF3, which are automatically designated as bus control outputs (\overline{AS} , \overline{RD} , \overline{HWR} , and \overline{LWR}) (in the 8-bit mode, pin PF3 is designated by PFDDR).

Pin PF0 is setting a PFDDR bit to 1 makes the corresponding port F pin an output port, while clearing the bit to 0 makes the pin an input port.

- Mode 7

Setting a PFDDR bit to 1 makes the corresponding port F pin PF6 to PF3, PF0 an output port, or in the case of pin PF7, the ϕ output pin. Clearing the bit to 0 makes the pin an input port.

Port F Data Register (PFDR)

Bit	:	7	6	5	4	3	2	1	0
		PF7DR	PF6DR	PF5DR	PF4DR	PF3DR	—	—	PF0DR
Initial value	:	0	0	0	0	0	undefined	undefined	0
R/W	:	R/W	R/W	R/W	R/W	R/W	—	—	R/W

PFDR is an 8-bit readable/writable register that stores output data for the port F pins (PF7 to PF3, PF0).

PFDR is initialized to B'00000**0 by a reset, and in hardware standby mode. It retains its prior state in software standby mode.

Port F Register (PORTF)

Bit	:	7	6	5	4	3	2	1	0
		PF7	PF6	PF5	PF4	PF3	—	—	PF0
Initial value	:	—*	—*	—*	—*	—*	undefined	undefined	—*
R/W	:	R	R	R	R	R	—	—	R

Note: * Determined by state of pins PF7 to PF3, PF0.

PORTF is an 8-bit read-only register that shows the pin states. It cannot be written to. Writing of output data for the port F pins (PF7 to PF3, PF0) must always be performed on PFDR.

If a port F read is performed while PFDDR bits are set to 1, the PFDR values are read. If a port F read is performed while PFDDR bits are cleared to 0, the pin states are read.

After a reset and in hardware standby mode, PORTF contents are determined by the pin states, as PFDDR and PFDR are initialized. PORTF retains its prior state in software standby mode.

9.11.3 Pin Functions

Port F pins also function as external interrupt input pins (IRQ2 and IRQ3), A/D trigger input pin ($\overline{\text{ADTRG}}$), bus control signal input/output pins ($\overline{\text{AS}}$, $\overline{\text{RD}}$, $\overline{\text{HWR}}$, $\overline{\text{LWR}}$), and the system clock (ϕ) output pin. The pin functions differ between modes 4 to 6, and mode 7. Port F pin functions are shown in table 9-20.

Table 9-20 Port F Pin Functions

Pin	Selection Method and Pin Functions		
PF7/ ϕ	The pin function is switched as shown below according to bit PF7DDR.		
	PF7DDR	0	1
	Pin function	PF7 input	ϕ output
PF6/ $\overline{\text{AS}}$	The pin function is switched as shown below according to bit PF6DDR.		
	Operating Mode	Modes 4 to 6	Mode 7
	PF6DDR	—	0 1
	Pin function	$\overline{\text{AS}}$ output	PF6 input PF6 output
PF5/ $\overline{\text{RD}}$	The pin function is switched as shown below according to the operating mode and bit PF5DDR.		
	Operating Mode	Modes 4 to 6	Mode 7
	PF5DDR	—	0 1
	Pin function	$\overline{\text{RD}}$ output	PF5 input PF5 output
PF4/ $\overline{\text{HWR}}$	The pin function is switched as shown below according to the operating mode and bit PF4DDR.		
	Operating Mode	Modes 4 to 6	Mode 7
	PF4DDR	—	0 1
	Pin function	$\overline{\text{HWR}}$ output	PF4 input PF4 output

Pin Selection Method and Pin Functions

PF3/ $\overline{\text{LWR}}$ /
 $\overline{\text{ADTRG}}$ / $\overline{\text{IRQ3}}$

The pin function is switched as shown below according to the operating mode, the bus mode, A/D converter bits TRGS1 and TRGS0, and bit PF3DDR.

Operating mode	Modes 4 to 6			Mode 7	
	16-bit bus mode	8-bit bus mode		—	
PF3DDR	—	0	1	0	1
Pin function	$\overline{\text{LWR}}$ output pin	PF3 input pin	PF3 output pin	PF3 input pin	PF3 output pin
		$\overline{\text{ADTRG}}$ input pin* ¹			
		$\overline{\text{IRQ3}}$ input pin* ²			

Notes: 1. $\overline{\text{ADTRG}}$ input when TRGS0 = TRGS1 = 1.

2. When used as an external interrupt input pin, do not use as an I/O pin for another function.

PF0/ $\overline{\text{IRQ2}}$

The pin function is switched as shown below according to the bit PF0DDR.

PF0DDR	0	1
Pin function	PF0 input	PF0 output
	$\overline{\text{IRQ2}}$ input	

9.12 Port H

9.12.1 Overview

Port H is an 8-bit I/O port. Port H pins also function as motor control PWM timer output pins (PWM1A to PWM1H).

Figure 9-22 shows the port H pin configuration.

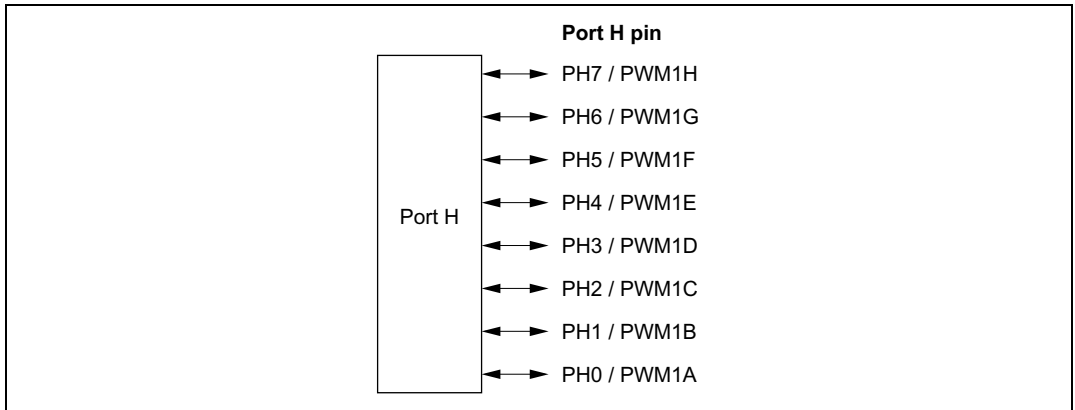

Figure 9-22 Port H Pin Functions

9.12.2 Register Configuration

Table 9-21 shows the port H register configuration.

Table 9-21 Port H Registers

Name	Abbreviation	R/W	Initial Value	Address*
Port H data direction register	PHDDR	W	H'00	H'FC20
Port H data register	PHDR	RW	H'00	H'FC24
Port H register	PORTH	R	Undefined	H'FC28

Note: * Lower 16 bits of the address.

Port H Data Direction Register (PHDDR)

Bit	:	7	6	5	4	3	2	1	0
		PH7DDR	PH6DDR	PH5DDR	PH4DDR	PH3DDR	PH2DDR	PH1DDR	PH0DDR
Initial value :		0	0	0	0	0	0	0	0
R/W	:	W	W	W	W	W	W	W	W

PHDDR is an 8-bit write-only register, the individual bits of which specify input or output for the pins of port H. PHDDR cannot be read. If it is, an undefined value will be read.

PHDDR is initialized to H'00 by a reset and in hardware standby mode. It retains its prior state in software standby mode.

Port H Data Register (PHDR)

Bit	:	7	6	5	4	3	2	1	0
		PH7DR	PH6DR	PH5DR	PH4DR	PH3DR	PH2DR	PH1DR	PH0DR
Initial value :		0	0	0	0	0	0	0	0
R/W	:	R/W	R/W	R/W	R/W	R/W	R/W	R/W	R/W

PHDR is an 8-bit readable/writeable register that stores output data for the port H pins (PH7 to PH0).

PHDR is initialized to H'00 by a reset and in hardware standby mode. It retains its prior state in software standby mode.

Port H Register (PORTH)

Bit	:	7	6	5	4	3	2	1	0
		PH7	PH6	PH5	PH4	PH3	PH2	PH1	PH0
Initial value :		—*	—*	—*	—*	—*	—*	—*	—*
R/W	:	R	R	R	R	R	R	R	R

Note: * Determined by the state of PH7 to PH0

PORTH is an 8-bit read-only register that shows the pin states. It cannot be written to. Writing of output data for the port H pins (PH7 to PH0) must always be performed on PHDR.

If a port H read is performed while PHDDR bits are set to 1, the PHDR values are read. If a port H read is performed while PHDDR bits are cleared to 0, the pin states are read.

After a reset and in hardware standby mode, PORTH contents are determined by the pin states, as PHDDR and PHDR are initialized. PORTH retains its prior state in software standby mode.

9.12.3 Pin Functions

As shown in table 9-22, the port H pin functions can be switched, bit by bit, by changing the values of OE1A to OE1H of motor control PWM timer PWOCR1 and PHDDR.

Table 9-22 Port H Pin Functions

OE1A to OE1H	1	0	
PHDDR	—	0	1
Pin function	PWM output	PH7 to PH0 input	PH7 to PH0 output

9.13 Port J

9.13.1 Overview

Port J is an 8-bit I/O port. Port J pins also function as motor control PWM timer output pins (PWM2A to PWM2H).

Figure 9-23 shows the port J pin configuration.

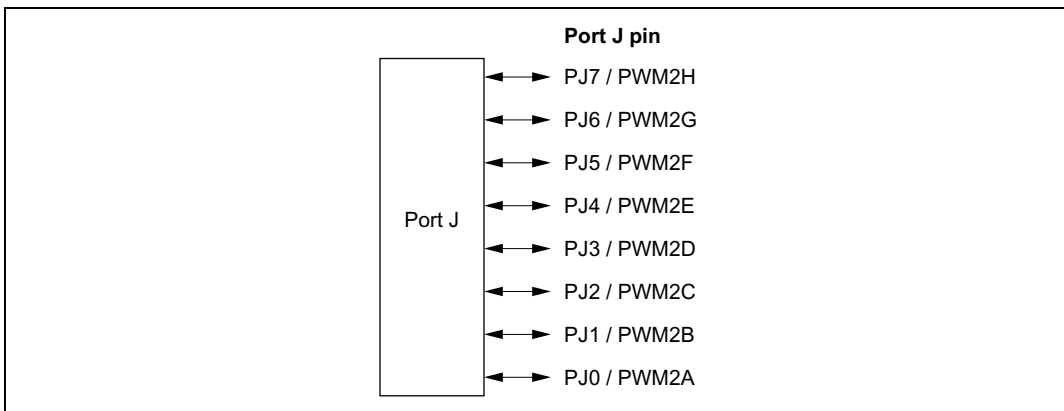

Figure 9-23 Port J Pin Functions

9.13.2 Register Configuration

Table 9-23 shows the port J register configuration.

Table 9-23 Port J Registers

Name	Abbreviation	R/W	Initial Value	Address*
Port J data direction register	PJDDR	W	H'00	H'FC21
Port J data register	PJDR	RW	H'00	H'FC25
Port J register	PORTJ	R	Undefined	H'FC29

Note: * Lower 16 bits of the address

Port J Data Direction Register (PJDDR)

Bit	:	7	6	5	4	3	2	1	0
		PJ7DDR	PJ6DDR	PJ5DDR	PJ4DDR	PJ3DDR	PJ2DDR	PJ1DDR	PJ0DDR
Initial value :		0	0	0	0	0	0	0	0
R/W	:	W	W	W	W	W	W	W	W

PJDDR is an 8-bit write-only register, the individual bits of which specify input or output for the pins of port J. PJDDR cannot be read. If it is, an undefined value will be read.

PJDDR is initialized to H'00 by a reset and in hardware standby mode. It retains its prior state in software standby mode.

Port J Data Register (PJDR)

Bit	:	7	6	5	4	3	2	1	0
		PJ7DR	PJ6DR	PJ5DR	PJ4DR	PJ3DR	PJ2DR	PJ1DR	PJ0DR
Initial value :		0	0	0	0	0	0	0	0
R/W	:	R/W	R/W	R/W	R/W	R/W	R/W	R/W	R/W

PJDR is an 8-bit readable/writeable register that stores output data for the port J pins (PJ7 to PJ0).

PJDR is initialized to H'00 by a reset and in hardware standby mode. It retains its prior state in software standby mode.

Port J Register (PORTJ)

Bit	:	7	6	5	4	3	2	1	0
		PJ7	PJ6	PJ5	PJ4	PJ3	PJ2	PJ1	PJ0
Initial value :		—*	—*	—*	—*	—*	—*	—*	—*
R/W	:	R	R	R	R	R	R	R	R

PORTJ is an 8-bit read-only register that shows the pin states. It cannot be written to. Writing of output data for the port J pins (PJ7 to PJ0) must always be performed on PJDR.

If a port J read is performed while PJDDR bits are set to 1, the PJDR values are read. If a port J read is performed while PJDDR bits are cleared to 0, the pin states are read.

After a reset and in hardware standby mode, PORTJ contents are determined by the pin states, as PJDDR and PJDR are initialized. PORTJ retains its prior state in software standby mode.

9.13.3 Pin Functions

As shown in table 9-24, the port J pin functions can be switched, bit by bit, by changing the values of OE2A to OE2H of motor control PWM timer PWOCR2 and PJDDR.

Table 9-24 Port J Pin Functions

OE2A to OE2H	1	0
PJDDR	—	0
Pin function	PWM output	PJ7 to PJ0 input
		PJ7 to PJ0 output

Section 10 16-Bit Timer Pulse Unit (TPU)

Note: The H8S/2635 Group is not equipped with a DTC or a PPG.

10.1 Overview

The chip has an on-chip 16-bit timer pulse unit (TPU) that comprises six 16-bit timer channels.

10.1.1 Features

- Maximum 16-pulse input/output
 - A total of 16 timer general registers (TGRs) are provided (four each for channels 0 and 3, and two each for channels 1, 2, 4, and 5), each of which can be set independently as an output compare/input capture register
 - TGRC and TGRD for channels 0 and 3 can also be used as buffer registers
- Selection of 8 counter input clocks for each channel
- The following operations can be set for each channel:
 - Waveform output at compare match: Selection of 0, 1, or toggle output
 - Input capture function: Selection of rising edge, falling edge, or both edge detection
 - Counter clear operation: Counter clearing possible by compare match or input capture
 - Synchronous operation: Multiple timer counters (TCNT) can be written to simultaneously
 - Simultaneous clearing by compare match and input capture possible
 - Register simultaneous input/output possible by counter synchronous operation
 - PWM mode: Any PWM output duty can be set
 - Maximum of 15-phase PWM output possible by combination with synchronous operation
- Buffer operation settable for channels 0 and 3
 - Input capture register double-buffering possible
 - Automatic rewriting of output compare register possible
- Phase counting mode settable independently for each of channels 1, 2, 4, and 5
 - Two-phase encoder pulse up/down-count possible
- Cascaded operation
 - Channel 2 (channel 5) input clock operates as 32-bit counter by setting channel 1 (channel 4) overflow/underflow
- Fast access via internal 16-bit bus
 - Fast access is possible via a 16-bit bus interface

- 26 interrupt sources
 - For channels 0 and 3, four compare match/input capture dual-function interrupts and one overflow interrupt can be requested independently
 - For channels 1, 2, 4, and 5, two compare match/input capture dual-function interrupts, one overflow interrupt, and one underflow interrupt can be requested independently
- Automatic transfer of register data
 - Block transfer, 1-word data transfer, and 1-byte data transfer possible by data transfer controller (DTC)
- Programmable pulse generator (PPG) output trigger can be generated
 - Channel 0 to 3 compare match/input capture signals can be used as PPG output trigger
- A/D converter conversion start trigger can be generated
 - Channel 0 to 5 compare match A/input capture A signals can be used as A/D converter conversion start trigger
- Module stop mode can be set
 - As the initial setting, TPU operation is halted. Register access is enabled by exiting module stop mode.

Table 10-1 lists the functions of the TPU.

Table 10-1 TPU Functions

Item	Channel 0	Channel 1	Channel 2	Channel 3	Channel 4	Channel 5
Count clock	$\phi/1$	$\phi/1$	$\phi/1$	$\phi/1$	$\phi/1$	$\phi/1$
	$\phi/4$	$\phi/4$	$\phi/4$	$\phi/4$	$\phi/4$	$\phi/4$
	$\phi/16$	$\phi/16$	$\phi/16$	$\phi/16$	$\phi/16$	$\phi/16$
	$\phi/64$	$\phi/64$	$\phi/64$	$\phi/64$	$\phi/64$	$\phi/64$
	TCLKA	$\phi/256$	$\phi/1024$	$\phi/256$	$\phi/1024$	$\phi/256$
	TCLKB	TCLKA	TCLKA	$\phi/1024$	TCLKA	TCLKA
	TCLKC	TCLKB	TCLKB	$\phi/4096$	TCLKC	TCLKC
TCLKD		TCLKC	TCLKA		TCLKD	
General registers	TGR0A	TGR1A	TGR2A	TGR3A	TGR4A	TGR5A
	TGR0B	TGR1B	TGR2B	TGR3B	TGR4B	TGR5B
General registers/ buffer registers	TGR0C	—	—	TGR3C	—	—
	TGR0D			TGR3D		
I/O pins	TIOCA0	TIOCA1	TIOCA2	TIOCA3	TIOCA4	TIOCA5
	TIOCB0	TIOCB1	TIOCB2	TIOCB3	TIOCB4	TIOCB5
	TIOCC0			TIOCC3		
	TIOCD0			TIOCD3		
Counter clear function	TGR compare match or input capture	TGR compare match or input capture	TGR compare match or input capture	TGR compare match or input capture	TGR compare match or input capture	TGR compare match or input capture
Compare match output	0 output	○	○	○	○	○
	1 output	○	○	○	○	○
	Toggle output	○	○	○	○	○
Input capture function	○	○	○	○	○	○
Synchronous operation	○	○	○	○	○	○
PWM mode	○	○	○	○	○	○
Phase counting mode	—	○	○	—	○	○
Buffer operation	○	—	—	○	—	—

Item	Channel 0	Channel 1	Channel 2	Channel 3	Channel 4	Channel 5
DTC activation	TGR compare match or input capture	TGR compare match or input capture	TGR compare match or input capture	TGR compare match or input capture	TGR compare match or input capture	TGR compare match or input capture
A/D converter trigger	TGR0A compare match or input capture	TGR1A compare match or input capture	TGR2A compare match or input capture	TGR3A compare match or input capture	TGR4A compare match or input capture	TGR5A compare match or input capture
PPG trigger	TGR0A/ TGR0B compare match or input capture	TGR1A/ TGR1B compare match or input capture	TGR2A/ TGR2B compare match or input capture	TGR3A/ TGR3B compare match or input capture	—	—
Interrupt sources	5 sources • Compare match or input capture 0A • Compare match or input capture 0B • Compare match or input capture 0C • Compare match or input capture 0D • Overflow	4 sources • Compare match or input capture 1A • Compare match or input capture 1B • Overflow • Underflow	4 sources • Compare match or input capture 2A • Compare match or input capture 2B • Overflow • Underflow	5 sources • Compare match or input capture 3A • Compare match or input capture 3B • Compare match or input capture 3C • Compare match or input capture 3D • Overflow	4 sources • Compare match or input capture 4A • Compare match or input capture 4B • Overflow • Underflow	4 sources • Compare match or input capture 5A • Compare match or input capture 5B • Overflow • Underflow

Legend:

○ : Possible

—: Not possible

10.1.2 Block Diagram

Figure 10-1 shows a block diagram of the TPU.

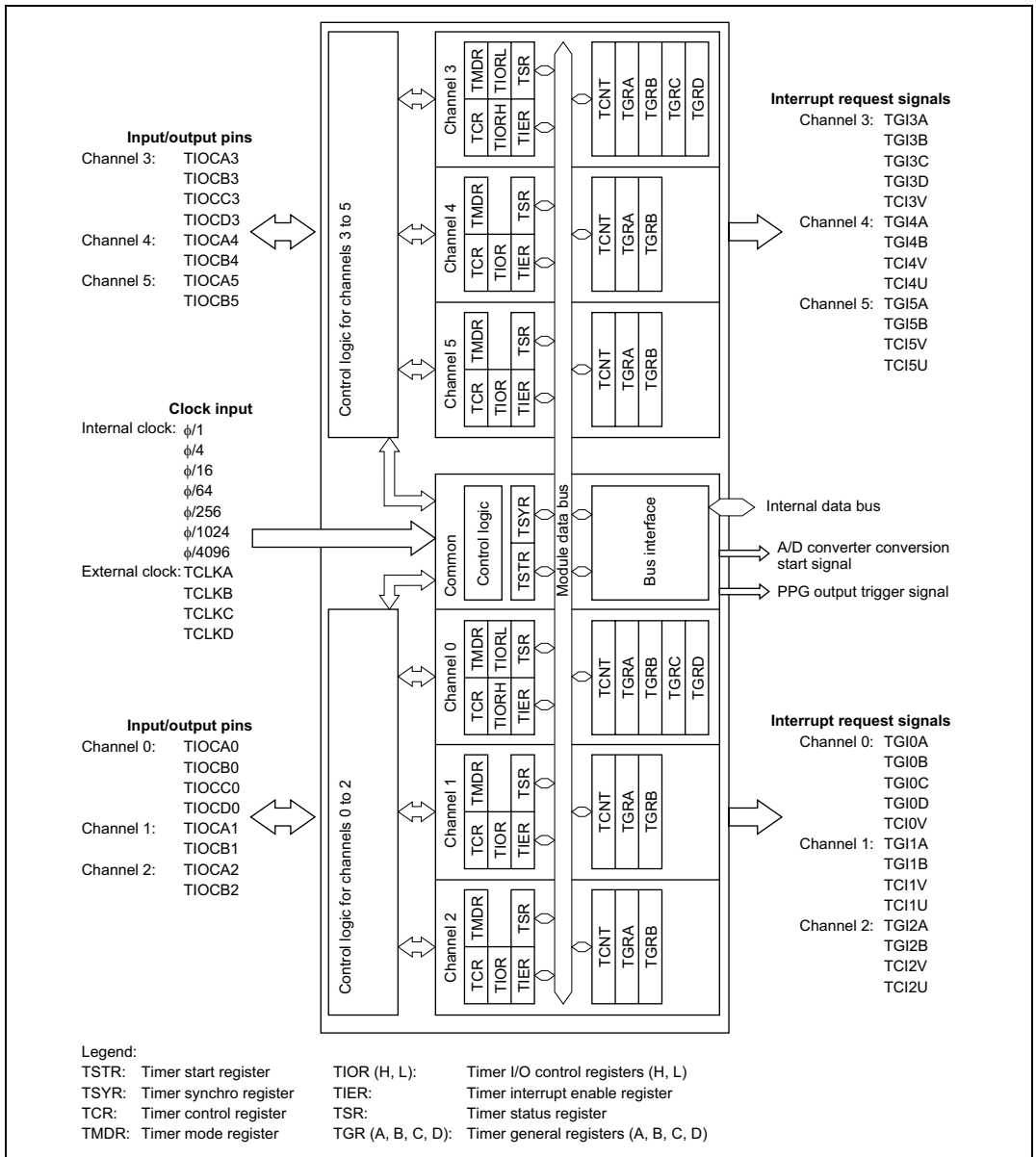

Figure 10-1 Block Diagram of TPU

10.1.3 Pin Configuration

Table 10-2 summarizes the TPU pins.

Table 10-2 TPU Pins

Channel	Name	Symbol	I/O	Function
All	Clock input A	TCLKA	Input	External clock A input pin (Channel 1 and 5 phase counting mode A phase input)
	Clock input B	TCLKB	Input	External clock B input pin (Channel 1 and 5 phase counting mode B phase input)
	Clock input C	TCLKC	Input	External clock C input pin (Channel 2 and 4 phase counting mode A phase input)
	Clock input D	TCLKD	Input	External clock D input pin (Channel 2 and 4 phase counting mode B phase input)
0	Input capture/output compare match A0	TIOCA0	I/O	TGR0A input capture input/output compare output/PWM output pin
	Input capture/output compare match B0	TIOCB0	I/O	TGR0B input capture input/output compare output/PWM output pin
	Input capture/output compare match C0	TIOCC0	I/O	TGR0C input capture input/output compare output/PWM output pin
	Input capture/output compare match D0	TIOCD0	I/O	TGR0D input capture input/output compare output/PWM output pin
1	Input capture/output compare match A1	TIOCA1	I/O	TGR1A input capture input/output compare output/PWM output pin
	Input capture/output compare match B1	TIOCB1	I/O	TGR1B input capture input/output compare output/PWM output pin
2	Input capture/output compare match A2	TIOCA2	I/O	TGR2A input capture input/output compare output/PWM output pin
	Input capture/output compare match B2	TIOCB2	I/O	TGR2B input capture input/output compare output/PWM output pin

Channel	Name	Symbol	I/O	Function
3	Input capture/out compare match A3	TIOCA3	I/O	TGR3A input capture input/output compare output/PWM output pin
	Input capture/out compare match B3	TIOCB3	I/O	TGR3B input capture input/output compare output/PWM output pin
	Input capture/out compare match C3	TIOCC3	I/O	TGR3C input capture input/output compare output/PWM output pin
	Input capture/out compare match D3	TIOCD3	I/O	TGR3D input capture input/output compare output/PWM output pin
4	Input capture/out compare match A4	TIOCA4	I/O	TGR4A input capture input/output compare output/PWM output pin
	Input capture/out compare match B4	TIOCB4	I/O	TGR4B input capture input/output compare output/PWM output pin
5	Input capture/out compare match A5	TIOCA5	I/O	TGR5A input capture input/output compare output/PWM output pin
	Input capture/out compare match B5	TIOCB5	I/O	TGR5B input capture input/output compare output/PWM output pin

10.1.4 Register Configuration

Table 10-3 summarizes the TPU registers.

Table 10-3 TPU Registers

Channel	Name	Abbreviation	R/W	Initial Value	Address ^{*1}
0	Timer control register 0	TCR0	R/W	H'00	H'FF10
	Timer mode register 0	TMDR0	R/W	H'C0	H'FF11
	Timer I/O control register 0H	TIOR0H	R/W	H'00	H'FF12
	Timer I/O control register 0L	TIOR0L	R/W	H'00	H'FF13
	Timer interrupt enable register 0	TIER0	R/W	H'40	H'FF14
	Timer status register 0	TSR0	R/(W) ^{*2}	H'C0	H'FF15
	Timer counter 0	TCNT0	R/W	H'0000	H'FF16
	Timer general register 0A	TGR0A	R/W	H'FFFF	H'FF18
	Timer general register 0B	TGR0B	R/W	H'FFFF	H'FF1A
	Timer general register 0C	TGR0C	R/W	H'FFFF	H'FF1C
Timer general register 0D	TGR0D	R/W	H'FFFF	H'FF1E	
1	Timer control register 1	TCR1	R/W	H'00	H'FF20
	Timer mode register 1	TMDR1	R/W	H'C0	H'FF21
	Timer I/O control register 1	TIOR1	R/W	H'00	H'FF22
	Timer interrupt enable register 1	TIER1	R/W	H'40	H'FF24
	Timer status register 1	TSR1	R/(W) ^{*2}	H'C0	H'FF25
	Timer counter 1	TCNT1	R/W	H'0000	H'FF26
	Timer general register 1A	TGR1A	R/W	H'FFFF	H'FF28
	Timer general register 1B	TGR1B	R/W	H'FFFF	H'FF2A
2	Timer control register 2	TCR2	R/W	H'00	H'FF30
	Timer mode register 2	TMDR2	R/W	H'C0	H'FF31
	Timer I/O control register 2	TIOR2	R/W	H'00	H'FF32
	Timer interrupt enable register 2	TIER2	R/W	H'40	H'FF34
	Timer status register 2	TSR2	R/(W) ^{*2}	H'C0	H'FF35
	Timer counter 2	TCNT2	R/W	H'0000	H'FF36
	Timer general register 2A	TGR2A	R/W	H'FFFF	H'FF38
Timer general register 2B	TGR2B	R/W	H'FFFF	H'FF3A	

Channel	Name	Abbreviation	R/W	Initial Value	Address*1
3	Timer control register 3	TCR3	R/W	H'00	H'FE80
	Timer mode register 3	TMDR3	R/W	H'C0	H'FE81
	Timer I/O control register 3H	TIOR3H	R/W	H'00	H'FE82
	Timer I/O control register 3L	TIOR3L	R/W	H'00	H'FE83
	Timer interrupt enable register 3	TIER3	R/W	H'40	H'FE84
	Timer status register 3	TSR3	R/(W)*2	H'C0	H'FE85
	Timer counter 3	TCNT3	R/W	H'0000	H'FE86
	Timer general register 3A	TGR3A	R/W	H'FFFF	H'FE88
	Timer general register 3B	TGR3B	R/W	H'FFFF	H'FE8A
	Timer general register 3C	TGR3C	R/W	H'FFFF	H'FE8C
	Timer general register 3D	TGR3D	R/W	H'FFFF	H'FE8E
4	Timer control register 4	TCR4	R/W	H'00	H'FE90
	Timer mode register 4	TMDR4	R/W	H'C0	H'FE91
	Timer I/O control register 4	TIOR4	R/W	H'00	H'FE92
	Timer interrupt enable register 4	TIER4	R/W	H'40	H'FE94
	Timer status register 4	TSR4	R/(W)*2	H'C0	H'FE95
	Timer counter 4	TCNT4	R/W	H'0000	H'FE96
	Timer general register 4A	TGR4A	R/W	H'FFFF	H'FE98
	Timer general register 4B	TGR4B	R/W	H'FFFF	H'FE9A
5	Timer control register 5	TCR5	R/W	H'00	H'FEA0
	Timer mode register 5	TMDR5	R/W	H'C0	H'FEA1
	Timer I/O control register 5	TIOR5	R/W	H'00	H'FEA2
	Timer interrupt enable register 5	TIER5	R/W	H'40	H'FEA4
	Timer status register 5	TSR5	R/(W)*2	H'C0	H'FEA5
	Timer counter 5	TCNT5	R/W	H'0000	H'FEA6
	Timer general register 5A	TGR5A	R/W	H'FFFF	H'FEA8
	Timer general register 5B	TGR5B	R/W	H'FFFF	H'FEAA
All	Timer start register	TSTR	R/W	H'00	H'FEB0
	Timer synchro register	TSYR	R/W	H'00	H'FEB1
	Module stop control register A	MSTPCRA	R/W	H'3F	H'FDE8

- Notes: 1. Lower 16 bits of the address.
 2. Can only be written with 0 for flag clearing.

10.2 Register Descriptions

10.2.1 Timer Control Register (TCR)

Channel 0: TCR0

Channel 3: TCR3

Bit	:	7	6	5	4	3	2	1	0
		CCLR2	CCLR1	CCLR0	CKEG1	CKEG0	TPSC2	TPSC1	TPSC0
Initial value :		0	0	0	0	0	0	0	0
R/W	:	R/W	R/W	R/W	R/W	R/W	R/W	R/W	R/W

Channel 1: TCR1

Channel 2: TCR2

Channel 4: TCR4

Channel 5: TCR5

Bit	:	7	6	5	4	3	2	1	0
		—	CCLR1	CCLR0	CKEG1	CKEG0	TPSC2	TPSC1	TPSC0
Initial value :		0	0	0	0	0	0	0	0
R/W	:	—	R/W	R/W	R/W	R/W	R/W	R/W	R/W

The TCR registers are 8-bit registers that control the TCNT channels. The TPU has six TCR registers, one for each of channels 0 to 5. The TCR registers are initialized to H'00 by a reset, and in hardware standby mode.

TCR register settings should be made only when TCNT operation is stopped.

Bits 7 to 5—Counter Clear 2, 1, and 0 (CCLR2, CCLR1, CCLR0): These bits select the TCNT counter clearing source.

Channel	Bit 7 CCLR2	Bit 6 CCLR1	Bit 5 CCLR0	Description	
0, 3	0	0	0	TCNT clearing disabled (Initial value)	
			1	TCNT cleared by TGRA compare match/input capture	
			1	0	TCNT cleared by TGRB compare match/input capture
				1	TCNT cleared by counter clearing for another channel performing synchronous clearing/synchronous operation ^{*1}
	1	0	0	TCNT clearing disabled	
			1	TCNT cleared by TGRC compare match/input capture ^{*2}	
			1	0	TCNT cleared by TGRD compare match/input capture ^{*2}
				1	TCNT cleared by counter clearing for another channel performing synchronous clearing/synchronous operation ^{*1}

Channel	Bit 7 Reserved ^{*3}	Bit 6 CCLR1	Bit 5 CCLR0	Description	
1, 2, 4, 5	0	0	0	TCNT clearing disabled (Initial value)	
			1	TCNT cleared by TGRA compare match/input capture	
			1	0	TCNT cleared by TGRB compare match/input capture
				1	TCNT cleared by counter clearing for another channel performing synchronous clearing/synchronous operation ^{*1}

- Notes:
1. Synchronous operation setting is performed by setting the SYNC bit in TSYR to 1.
 2. When TGRC or TGRD is used as a buffer register, TCNT is not cleared because the buffer register setting has priority, and compare match/input capture does not occur.
 3. Bit 7 is reserved in channels 1, 2, 4, and 5. It is always read as 0 and cannot be modified.

Bits 4 and 3—Clock Edge 1 and 0 (CKEG1, CKEG0): These bits select the input clock edge. When the input clock is counted using both edges, the input clock period is halved (e.g. $\phi/4$ both edges = $\phi/2$ rising edge). If phase counting mode is used on channels 1, 2, 4, and 5, this setting is ignored and the phase counting mode setting has priority.

Bit 4 CKEG1	Bit 3 CKEG0	Description	
0	0	Count at rising edge	(Initial value)
	1	Count at falling edge	
1	—	Count at both edges	

Note: Internal clock edge selection is valid when the input clock is $\phi/4$ or slower. This setting is ignored if the input clock is $\phi/1$, or when overflow/underflow of another channel is selected.

Bits 2 to 0—Time Prescaler 2, 1, and 0 (TPSC2 to TPSC0): These bits select the TCNT counter clock. The clock source can be selected independently for each channel. Table 10-4 shows the clock sources that can be set for each channel.

Table 10-4 TPU Clock Sources

Channel	Internal Clock							External Clock				Overflow/ Underflow on Another Channel
	$\phi/1$	$\phi/4$	$\phi/16$	$\phi/64$	$\phi/256$	$\phi/1024$	$\phi/4096$	TCLKA	TCLKB	TCLKC	TCLKD	
0	○	○	○	○				○	○	○	○	
1	○	○	○	○	○			○	○			○
2	○	○	○	○		○		○	○	○		
3	○	○	○	○	○	○	○	○				
4	○	○	○	○		○		○		○		○
5	○	○	○	○	○			○		○	○	

Legend:

○ : Setting

Blank: No setting

Channel	Bit 2 TPSC2	Bit 1 TPSC1	Bit 0 TPSC0	Description	
0	0	0	0	Internal clock: counts on $\phi/1$ (Initial value)	
			1	Internal clock: counts on $\phi/4$	
			1	0	Internal clock: counts on $\phi/16$
				1	Internal clock: counts on $\phi/64$
	1	0	0	External clock: counts on TCLKA pin input	
			1	External clock: counts on TCLKB pin input	
			1	0	External clock: counts on TCLKC pin input
				1	External clock: counts on TCLKD pin input

Channel	Bit 2 TPSC2	Bit 1 TPSC1	Bit 0 TPSC0	Description	
1	0	0	0	Internal clock: counts on $\phi/1$ (Initial value)	
			1	Internal clock: counts on $\phi/4$	
			1	0	Internal clock: counts on $\phi/16$
				1	Internal clock: counts on $\phi/64$
	1	0	0	External clock: counts on TCLKA pin input	
			1	External clock: counts on TCLKB pin input	
			1	0	Internal clock: counts on $\phi/256$
				1	Counts on TCNT2 overflow/underflow

Note: This setting is ignored when channel 1 is in phase counting mode.

Channel	Bit 2 TPSC2	Bit 1 TPSC1	Bit 0 TPSC0	Description	
2	0	0	0	Internal clock: counts on $\phi/1$ (Initial value)	
			1	Internal clock: counts on $\phi/4$	
			1	0	Internal clock: counts on $\phi/16$
				1	Internal clock: counts on $\phi/64$
	1	0	0	External clock: counts on TCLKA pin input	
			1	External clock: counts on TCLKB pin input	
			1	0	External clock: counts on TCLKC pin input
				1	Internal clock: counts on $\phi/1024$

Note: This setting is ignored when channel 2 is in phase counting mode.

Channel	Bit 2 TPSC2	Bit 1 TPSC1	Bit 0 TPSC0	Description
3	0		0	Internal clock: counts on $\phi/1$ (Initial value)
			1	Internal clock: counts on $\phi/4$
			0	Internal clock: counts on $\phi/16$
			1	Internal clock: counts on $\phi/64$
	1		0	External clock: counts on TCLKA pin input
			1	Internal clock: counts on $\phi/1024$
			0	Internal clock: counts on $\phi/256$
			1	Internal clock: counts on $\phi/4096$

Channel	Bit 2 TPSC2	Bit 1 TPSC1	Bit 0 TPSC0	Description
4	0		0	Internal clock: counts on $\phi/1$ (Initial value)
			1	Internal clock: counts on $\phi/4$
			0	Internal clock: counts on $\phi/16$
			1	Internal clock: counts on $\phi/64$
	1		0	External clock: counts on TCLKA pin input
			1	External clock: counts on TCLKC pin input
			0	Internal clock: counts on $\phi/1024$
			1	Counts on TCNT5 overflow/underflow

Note: This setting is ignored when channel 4 is in phase counting mode.

Channel	Bit 2 TPSC2	Bit 1 TPSC1	Bit 0 TPSC0	Description
5	0		0	Internal clock: counts on $\phi/1$ (Initial value)
			1	Internal clock: counts on $\phi/4$
			0	Internal clock: counts on $\phi/16$
			1	Internal clock: counts on $\phi/64$
	1		0	External clock: counts on TCLKA pin input
			1	External clock: counts on TCLKC pin input
			0	Internal clock: counts on $\phi/256$
			1	External clock: counts on TCLKD pin input

Note: This setting is ignored when channel 5 is in phase counting mode.

10.2.2 Timer Mode Register (TMDR)

Channel 0: TMDR0

Channel 3: TMDR3

Bit	:	7	6	5	4	3	2	1	0
		—	—	BFB	BFA	MD3	MD2	MD1	MD0
Initial value :		1	1	0	0	0	0	0	0
R/W	:	—	—	R/W	R/W	R/W	R/W	R/W	R/W

Channel 1: TMDR1

Channel 2: TMDR2

Channel 4: TMDR4

Channel 5: TMDR5

Bit	:	7	6	5	4	3	2	1	0
		—	—	—	—	MD3	MD2	MD1	MD0
Initial value :		1	1	0	0	0	0	0	0
R/W	:	—	—	—	—	R/W	R/W	R/W	R/W

The TMDR registers are 8-bit readable/writable registers that are used to set the operating mode for each channel. The TPU has six TMDR registers, one for each channel. The TMDR registers are initialized to H'C0 by a reset, and in hardware standby mode.

TMDR register settings should be made only when TCNT operation is stopped.

Bits 7 and 6—Reserved: These bits are always read as 1 and cannot be modified.

Bit 5—Buffer Operation B (BFB): Specifies whether TGRB is to operate in the normal way, or TGRB and TGRD are to be used together for buffer operation. When TGRD is used as a buffer register, TGRD input capture/output compare is not generated.

In channels 1, 2, 4, and 5, which have no TGRD, bit 5 is reserved. It is always read as 0 and cannot be modified.

Bit 5

BFB	Description
0	TGRB operates normally (Initial value)
1	TGRB and TGRD used together for buffer operation

Bit 4—Buffer Operation A (BFA): Specifies whether TGRA is to operate in the normal way, or TGRA and TGRC are to be used together for buffer operation. When TGRC is used as a buffer register, TGRC input capture/output compare is not generated.

In channels 1, 2, 4, and 5, which have no TGRC, bit 4 is reserved. It is always read as 0 and cannot be modified.

Bit 4 BFA	Description	
0	TGRA operates normally	(Initial value)
1	TGRA and TGRC used together for buffer operation	

Bits 3 to 0—Modes 3 to 0 (MD3 to MD0): These bits are used to set the timer operating mode.

Bit 3 MD3* ¹	Bit 2 MD2* ²	Bit 1 MD1	Bit 0 MD0	Description			
0	0	0	0	Normal operation	(Initial value)		
			1	Reserved			
	1	0	1	0	PWM mode 1		
				1	PWM mode 2		
			0	1	0	Phase counting mode 1	
					1	Phase counting mode 2	
		1	0	1	0	Phase counting mode 3	
					1	Phase counting mode 4	
1	*	*	*	—			

*: Don't care

- Notes: 1. MD3 is a reserved bit. In a write, it should always be written with 0.
2. Phase counting mode cannot be set for channels 0 and 3. In this case, 0 should always be written to MD2.

10.2.3 Timer I/O Control Register (TIOR)

Channel 0: TIOR0H

Channel 1: TIOR1

Channel 2: TIOR2

Channel 3: TIOR3H

Channel 4: TIOR4

Channel 5: TIOR5

Bit	:	7	6	5	4	3	2	1	0
		IOB3	IOB2	IOB1	IOB0	IOA3	IOA2	IOA1	IOA0
Initial value :		0	0	0	0	0	0	0	0
R/W	:	R/W	R/W	R/W	R/W	R/W	R/W	R/W	R/W

Channel 0: TIOR0L

Channel 3: TIOR3L

Bit	:	7	6	5	4	3	2	1	0
		IOD3	IOD2	IOD1	IOD0	IOC3	IOC2	IOC1	IOC0
Initial value :		0	0	0	0	0	0	0	0
R/W	:	R/W	R/W	R/W	R/W	R/W	R/W	R/W	R/W

Note: When TGRC or TGRD is designated for buffer operation, this setting is invalid and the register operates as a buffer register.

The TIOR registers are 8-bit registers that control the TGR registers. The TPU has eight TIOR registers, two each for channels 0 and 3, and one each for channels 1, 2, 4, and 5. The TIOR registers are initialized to H'00 by a reset, and in hardware standby mode.

Care is required since TIOR is affected by the TMDR setting. The initial output specified by TIOR is valid when the counter is stopped (the CST bit in TSTR is cleared to 0). Note also that, in PWM mode 2, the output at the point at which the counter is cleared to 0 is specified.

Bits 7 to 4— I/O Control B3 to B0 (IOB3 to IOB0)**I/O Control D3 to D0 (IOD3 to IOD0):**

Bits IOB3 to IOB0 specify the function of TGRB.

Bits IOD3 to IOD0 specify the function of TGRD.

Channel	Bit 7	Bit 6	Bit 5	Bit 4	Description		
	IOB3	IOB2	IOB1	IOB0			
0	0	0	0	0	TGR0B	Output disabled	(Initial value)
				1	is output capture register	Initial output is 0 output	0 output at compare match
				0		0 output	1 output at compare match
				1		Toggle output at compare match	
	1	0	0	0		Output disabled	
				1		Initial output is 1 output	0 output at compare match
				0		1 output	1 output at compare match
				1		Toggle output at compare match	
	1	0	0	0	TGR0B	Capture input source is TIOCB0 pin	Input capture at rising edge
				1	is input capture register		Input capture at falling edge
				1	*		Input capture at both edges
				1	*	*	Capture input source is channel 1/count clock

*: Don't care

Note: 1. When bits TPSC2 to TPSC0 in TCR1 are set to B'000 and $\phi/1$ is used as the TCNT1 count clock, this setting is invalid and input capture is not generated.

Channel	Bit 7 IOD3	Bit 6 IOD2	Bit 5 IOD1	Bit 4 IOD0	Description	
0	0	0	0	0	TGR0D	Output disabled (Initial value)
				1	is output	Initial output is 0
				0	compare	0 output at compare match
				1	register*2	1 output at compare match
	1	0	0	0		Toggle output at compare match
				1		Output disabled
				0		Initial output is 1
				1		0 output at compare match
	1	0	0	0		1 output at compare match
				1		Toggle output at compare match
				0		Input capture at rising edge
				1		Input capture at falling edge
1	0	0	0	TGR0D	Input capture at both edges	
			1	is input	Capture input source is	
			*	capture	TIOCD0 pin	
			*	register*2	Capture input source is channel	
1	0	0	0		Input capture at TCNT1	
			1		count-up/count-down*1	
			*		1/count clock	
			*			

*: Don't care

- Notes: 1. When bits TPSC2 to TPSC0 in TCR1 are set to B'000 and $\phi/1$ is used as the TCNT1 count clock, this setting is invalid and input capture is not generated.
2. When the BFB bit in TMDR0 is set to 1 and TGR0D is used as a buffer register, this setting is invalid and input capture/output compare is not generated.

Channel	Bit 7 IOB3	Bit 6 IOB2	Bit 5 IOB1	Bit 4 IOB0	Description		
1	0	0	0	0	TGR1B is output compare register	Output disabled (Initial value)	
				1		Initial output is 0 output	0 output at compare match
				0		1 output at compare match	
				1		Toggle output at compare match	
	1	0	0	0		Output disabled	
				1		Initial output is 1 output	0 output at compare match
				0		1 output at compare match	
				1		Toggle output at compare match	
	1	0	0	0	TGR1B is input capture register	Capture input source is TIOCB1 pin	Input capture at rising edge
				1			Input capture at falling edge
				*			Input capture at both edges
				*			Capture input source is TGR0C compare match/ input capture

*: Don't care

Channel	Bit 7 IOB3	Bit 6 IOB2	Bit 5 IOB1	Bit 4 IOB0	Description			
2	0	0	0	0	TGR2B is output compare register	Output disabled	(Initial value)	
				1			Initial output is 0 output	0 output at compare match
				1			1 output at compare match	
				1			Toggle output at compare match	
	1	0	0	0	TGR2B is input capture register	Output disabled		
				1			Initial output is 1 output	0 output at compare match
				1			1 output at compare match	
				1			Toggle output at compare match	
	1	*	0	0	TGR2B is input capture register	Capture input source is TIOCB2 pin	Input capture at rising edge	
				1			Input capture at falling edge	
				1			Input capture at both edges	
				*				

*: Don't care

Channel	Bit 7	Bit 6	Bit 5	Bit 4	Description		
	IOB3	IOB2	IOB1	IOB0			
3	0	0	0	0	TGR3B is output compare register	Output disabled	(Initial value)
				1		Initial output is 0 output	0 output at compare match
				1		0	1 output at compare match
				1			Toggle output at compare match
	1	0	0	0	TGR3B is input capture register	Output disabled	
				1		Initial output is 1 output	0 output at compare match
				1		0	1 output at compare match
				1			Toggle output at compare match
1	0	0	0	TGR3B is input capture register	Capture input source is TIOCB3 pin	Input capture at rising edge	
			1			Input capture at falling edge	
			1		*	Input capture at both edges	
			1		*	*	Capture input source is channel 4/count clock

*: Don't care

Note: 1. When bits TPSC2 to TPSC0 in TCR4 are set to B'000 and $\phi/1$ is used as the TCNT4 count clock, this setting is invalid and input capture is not generated.

Channel	Bit 7 IOD3	Bit 6 IOD2	Bit 5 IOD1	Bit 4 IOD0	Description	
3	0	0	0	0	TGR3D is output	Output disabled (Initial value)
				1	is output	Initial output is 0
				0	compare register*2	0 output at compare match
				1		1 output at compare match
	1	0	0	0		Toggle output at compare match
				1		Output disabled
				0		Initial output is 1
				1		0 output at compare match
				0		1 output at compare match
				1		Toggle output at compare match
1	0	0	0	TGR3D is input	Input capture at rising edge	
			1	capture source is	Input capture at falling edge	
			*	capture register*2	Input capture at both edges	
			*		Input capture at TCNT4	
1	*	*	*		count-up/count-down*1	
					4/count clock	

*: Don't care

- Notes: 1. When bits TPSC2 to TPSC0 in TCR4 are set to B'000 and $\phi/1$ is used as the TCNT4 count clock, this setting is invalid and input capture is not generated.
2. When the BFB bit in TMDR3 is set to 1 and TGR3D is used as a buffer register, this setting is invalid and input capture/output compare is not generated.

Channel	Bit 7	Bit 6	Bit 5	Bit 4	Description		
	IOB3	IOB2	IOB1	IOB0			
4	0	0	0	0	TGR4B is output compare register	Output disabled (Initial value)	
				1		Initial output is 0 output	0 output at compare match
				1		1 output at compare match	Toggle output at compare match
				1			
	1	0	0	0		Output disabled	
				1	Initial output is 1 output	0 output at compare match	
				1	1 output at compare match	Toggle output at compare match	
				1			
1	0	0	0	TGR4B is input capture register	Capture input source is TIOCB4 pin	Input capture at rising edge	
			1		Input capture at falling edge		
			1		Input capture at both edges		
			1		Input capture at generation of TGR3C compare match/ input capture		

*: Don't care

Channel	Bit 7	Bit 6	Bit 5	Bit 4	Description		
	IOB3	IOB2	IOB1	IOB0			
5	0	0	0	0	TGR5B is output compare register	Output disabled (Initial value)	
				1		Initial output is 0 output	0 output at compare match
				1		1 output at compare match	Toggle output at compare match
				1			
	1	0	0	0		Output disabled	
				1	Initial output is 1 output	0 output at compare match	
				1	1 output at compare match	Toggle output at compare match	
				1			
1	*	0	0	TGR5B is input capture register	Capture input source is TIOCB5 pin	Input capture at rising edge	
			1		Input capture at falling edge		
			1		Input capture at both edges		
			1				

*: Don't care

Bits 3 to 0— I/O Control A3 to A0 (IOA3 to IOA0)**I/O Control C3 to C0 (IOC3 to IOC0):**

IOA3 to IOA0 specify the function of TGRA.

IOC3 to IOC0 specify the function of TGRC.

Channel	Bit 3 IOA3	Bit 2 IOA2	Bit 1 IOA1	Bit 0 IOA0	Description
0	0	0	0	0	TGR0A Output disabled (Initial value)
				1	is output compare register
				0	Initial output is 0 output
				1	0 output at compare match
	1	0	0	0	Initial output is 1 output
				1	0 output at compare match
				0	1 output at compare match
				1	Toggle output at compare match
	1	0	0	0	Capture input source is TIOCA0 pin
				1	Input capture at rising edge
				*	Input capture at falling edge
				*	Input capture at both edges
1	*	*	*	Capture input source is channel 1/ count clock	
			*	Input capture at TCNT1 count-up/count-down	

*: Don't care

Channel	Bit 3	Bit 2	Bit 1	Bit 0	Description		
	IOC3	IOC2	IOC1	IOC0			
0	0	0	0	0	TGR0C	Output disabled	(Initial value)
				1	is output compare register*1	Initial output is 0 output	0 output at compare match
				0		1 output at compare match	
				1		Toggle output at compare match	
	1	0	0	0		Output disabled	
				1		Initial output is 1 output	0 output at compare match
				0		1 output at compare match	
				1		Toggle output at compare match	
1	0	0	0	TGR0C	Capture input source is TIOCC0 pin	Input capture at rising edge	
			1	is input capture register*1	Input capture at falling edge		
			*		Input capture at both edges		
			*	*	Capture input source is channel 1/count clock	Input capture at TCNT1 count-up/count-down	

*: Don't care

Note: 1. When the BFA bit in TMDR0 is set to 1 and TGR0C is used as a buffer register, this setting is invalid and input capture/output compare is not generated.

Channel	Bit 3 IOA3	Bit 2 IOA2	Bit 1 IOA1	Bit 0 IOA0	Description			
1	0	0	0	0	TGR1A is output compare register	Output disabled	(Initial value)	
				1			Initial output is 0 output	0 output at compare match
				0			1 output at compare match	
				1			Toggle output at compare match	
	1	0	0	0	TGR1A is input capture register	Output disabled		
				1			Initial output is 1 output	0 output at compare match
				0			1 output at compare match	
				1			Toggle output at compare match	
	1	0	0	0	TGR1A is input capture register	Capture input source is TIOCA1 pin	Input capture at rising edge	
				1			Input capture at falling edge	
				*			Input capture at both edges	
				*			Input capture at generation of channel 0/TGR0A compare match/input capture	

*: Don't care

Channel	Bit 3 IOA3	Bit 2 IOA2	Bit 1 IOA1	Bit 0 IOA0	Description			
2	0	0	0	0	TGR2A is output compare register	Output disabled	(Initial value)	
				1			Initial output is 0 output	0 output at compare match
				0			1 output at compare match	
				1			Toggle output at compare match	
	1	0	0	0	TGR2A is input capture register	Output disabled		
				1			Initial output is 1 output	0 output at compare match
				0			1 output at compare match	
				1			Toggle output at compare match	
	1	*	0	0	TGR2A is input capture register	Capture input source is TIOCA2 pin	Input capture at rising edge	
				1			Input capture at falling edge	
				*			Input capture at both edges	

*: Don't care

Channel	Bit 3	Bit 2	Bit 1	Bit 0	Description		
	IOA3	IOA2	IOA1	IOA0			
3	0	0	0	0	TGR3A is output compare register	Output disabled	(Initial value)
				1		Initial output is 0 output	0 output at compare match
				0		1 output at compare match	
				1		Toggle output at compare match	
	1	0	0	0	TGR3A is input capture register	Output disabled	
				1		Initial output is 1 output	0 output at compare match
				0		1 output at compare match	
				1		Toggle output at compare match	
1	0	0	0	TGR3A is input capture register	Capture input source is TIOCA3 pin	Input capture at rising edge	
			1		Input capture at falling edge		
			*		Input capture at both edges		
			*		Capture input source is channel 4/count clock	Input capture at TCNT4 count-up/count-down	

*: Don't care

Channel	Bit 3	Bit 2	Bit 1	Bit 0	Description		
	IOC3	IOC2	IOC1	IOC0			
3	0	0	0	0	TGR3C is output compare register*1	Output disabled	(Initial value)
				1		Initial output is 0 output	0 output at compare match
				1		0	1 output at compare match
				1		Toggle output at compare match	
	1	0	0	0	TGR3C is input capture register*1	Output disabled	
				1		Initial output is 1 output	0 output at compare match
				1		0	1 output at compare match
				1		Toggle output at compare match	
	1	0	0	0	TGR3C is input capture register*1	Capture input source is TIOCC3 pin	Input capture at rising edge
				1			Input capture at falling edge
				1		*	Input capture at both edges
				1		*	*

*: Don't care

Note: 1. When the BFA bit in TMDR3 is set to 1 and TGR3C is used as a buffer register, this setting is invalid and input capture/output compare is not generated.

Channel	Bit 3	Bit 2	Bit 1	Bit 0	Description					
	IOA3	IOA2	IOA1	IOA0						
4	0	0	0	0	TGR4A is output compare register	Output disabled	(Initial value)			
				1				Initial output is 0 output	0	0 output at compare match
				1					0	1 output at compare match
				1					Toggle output at compare match	
				1				0	0	Output disabled
	1	0	0	Initial output is 1 output	0 output at compare match					
	1	0	0	0	TGR4A is input capture register	Capture input source is TIOCA4 pin	Input capture at rising edge			
				1				Input capture at falling edge		
				1				*	Input capture at both edges	
				1				*	*	Capture input source is TGR3A compare match/ input capture
1				*				*		

*: Don't care

Channel	Bit 3	Bit 2	Bit 1	Bit 0	Description					
	IOA3	IOA2	IOA1	IOA0						
5	0	0	0	0	TGR5A is output compare register	Output disabled	(Initial value)			
				1				Initial output is 0 output	0	0 output at compare match
				1					0	1 output at compare match
				1					Toggle output at compare match	
				1				0	0	Output disabled
	1	0	0	Initial output is 1 output	0 output at compare match					
	1	*	0	0	TGR5A is input capture register	Capture input source is TIOCA5 pin	Input capture at rising edge			
				1				Input capture at falling edge		
				1				*	Input capture at both edges	
				1				*	*	
1				*				*		

*: Don't care

10.2.4 Timer Interrupt Enable Register (TIER)

Channel 0: TIER0

Channel 3: TIER3

Bit	:	7	6	5	4	3	2	1	0
		TTGE	—	—	TCIEV	TGIED	TGIEC	TGIEB	TGIEA
Initial value :		0	1	0	0	0	0	0	0
R/W	:	R/W	—	—	R/W	R/W	R/W	R/W	R/W

Channel 1: TIER1

Channel 2: TIER2

Channel 4: TIER4

Channel 5: TIER5

Bit	:	7	6	5	4	3	2	1	0
		TTGE	—	TCIEU	TCIEV	—	—	TGIEB	TGIEA
Initial value :		0	1	0	0	0	0	0	0
R/W	:	R/W	—	R/W	R/W	—	—	R/W	R/W

The TIER registers are 8-bit registers that control enabling or disabling of interrupt requests for each channel. The TPU has six TIER registers, one for each channel. The TIER registers are initialized to H'40 by a reset, and in hardware standby mode.

Bit 7—A/D Conversion Start Request Enable (TTGE): Enables or disables generation of A/D conversion start requests by TGRA input capture/compare match.

Bit 7 TTGE	Description	
0	A/D conversion start request generation disabled	(Initial value)
1	A/D conversion start request generation enabled	

Bit 6—Reserved: This bit is always read as 1 and cannot be modified.

Bit 5—Underflow Interrupt Enable (TCIEU): Enables or disables interrupt requests (TCIU) by the TCFU flag when the TCFU flag in TSR is set to 1 in channels 1, 2, 4, and 5.

In channels 0 and 3, bit 5 is reserved. It is always read as 0 and cannot be modified.

Bit 5 TCIEU	Description	
0	Interrupt requests (TCIU) by TCFU disabled	(Initial value)
1	Interrupt requests (TCIU) by TCFU enabled	

Bit 4—Overflow Interrupt Enable (TCIEV): Enables or disables interrupt requests (TCIV) by the TCFV flag when the TCFV flag in TSR is set to 1.

Bit 4 TCIEV	Description	
0	Interrupt requests (TCIV) by TCFV disabled	(Initial value)
1	Interrupt requests (TCIV) by TCFV enabled	

Bit 3—TGR Interrupt Enable D (TGIED): Enables or disables interrupt requests (TGID) by the TGFD bit when the TGFD bit in TSR is set to 1 in channels 0 and 3.

In channels 1, 2, 4, and 5, bit 3 is reserved. It is always read as 0 and cannot be modified.

Bit 3 TGIED	Description	
0	Interrupt requests (TGID) by TGFD bit disabled	(Initial value)
1	Interrupt requests (TGID) by TGFD bit enabled	

Bit 2—TGR Interrupt Enable C (TGIEC): Enables or disables interrupt requests (TGIC) by the TGFC bit when the TGFC bit in TSR is set to 1 in channels 0 and 3.

In channels 1, 2, 4, and 5, bit 2 is reserved. It is always read as 0 and cannot be modified.

Bit 2

TGIEC	Description	
0	Interrupt requests (TGIC) by TGFC bit disabled	(Initial value)
1	Interrupt requests (TGIC) by TGFC bit enabled	

Bit 1—TGR Interrupt Enable B (TGIEB): Enables or disables interrupt requests (TGIB) by the TGFB bit when the TGFB bit in TSR is set to 1.

Bit 1

TGIEB	Description	
0	Interrupt requests (TGIB) by TGFB bit disabled	(Initial value)
1	Interrupt requests (TGIB) by TGFB bit enabled	

Bit 0—TGR Interrupt Enable A (TGIEA): Enables or disables interrupt requests (TGIA) by the TGFA bit when the TGFA bit in TSR is set to 1.

Bit 0

TGIEA	Description	
0	Interrupt requests (TGIA) by TGFA bit disabled	(Initial value)
1	Interrupt requests (TGIA) by TGFA bit enabled	

10.2.5 Timer Status Register (TSR)

Channel 0: TSR0

Channel 3: TSR3

Bit	:	7	6	5	4	3	2	1	0
		—	—	—	TCFV	TGFD	TGFC	TGFB	TGFA
Initial value	:	1	1	0	0	0	0	0	0
R/W	:	—	—	—	R/(W)*	R/(W)*	R/(W)*	R/(W)*	R/(W)*

Note: * Can only be written with 0 for flag clearing.

Channel 1: TSR1

Channel 2: TSR2

Channel 4: TSR4

Channel 5: TSR5

Bit	:	7	6	5	4	3	2	1	0
		TCFD	—	TCFU	TCFV	—	—	TGFB	TGFA
Initial value	:	1	1	0	0	0	0	0	0
R/W	:	R	—	R/(W)*	R/(W)*	—	—	R/(W)*	R/(W)*

Note: * Can only be written with 0 for flag clearing.

The TSR registers are 8-bit registers that indicate the status of each channel. The TPU has six TSR registers, one for each channel. The TSR registers are initialized to H'00 by a reset, and in hardware standby mode.

Bit 7—Count Direction Flag (TCFD): Status flag that shows the direction in which TCNT counts in channels 1, 2, 4, and 5.

In channels 0 and 3, bit 7 is reserved. It is always read as 1 and cannot be modified.

Bit 7 TCFD	Description	
0	TCNT counts down	
1	TCNT counts up	(Initial value)

Bit 6—Reserved: This bit is always read as 1 and cannot be modified.

Bit 5—Underflow Flag (TCFU): Status flag that indicates that TCNT underflow has occurred when channels 1, 2, 4, and 5 are set to phase counting mode.

In channels 0 and 3, bit 5 is reserved. It is always read as 0 and cannot be modified.

Bit 5 TCFU	Description	
0	[Clearing condition]	(Initial value)
	<ul style="list-style-type: none"> When 0 is written to TCFU after reading TCFU = 1 	
1	[Setting condition]	
	<ul style="list-style-type: none"> When the TCNT value underflows (changes from H'0000 to H'FFFF) 	

Bit 4—Overflow Flag (TCFV): Status flag that indicates that TCNT overflow has occurred.

Bit 4 TCFV	Description	
0	[Clearing condition]	(Initial value)
	<ul style="list-style-type: none"> When 0 is written to TCFV after reading TCFV = 1 	
1	[Setting condition]	
	<ul style="list-style-type: none"> When the TCNT value overflows (changes from H'FFFF to H'0000) 	

Bit 3—Input Capture/Output Compare Flag D (TGFD): Status flag that indicates the occurrence of TGRD input capture or compare match in channels 0 and 3.

In channels 1, 2, 4, and 5, bit 3 is reserved. It is always read as 0 and cannot be modified.

Bit 3

TGFD	Description
0	[Clearing conditions] (Initial value) <ul style="list-style-type: none"> When DTC is activated by TGID interrupt while DISEL bit of MRB in DTC is 0 When 0 is written to TGFD after reading TGFD = 1
1	[Setting conditions] <ul style="list-style-type: none"> When TCNT = TGRD while TGRD is functioning as output compare register When TCNT value is transferred to TGRD by input capture signal while TGRD is functioning as input capture register

Bit 2—Input Capture/Output Compare Flag C (TGFC): Status flag that indicates the occurrence of TGRC input capture or compare match in channels 0 and 3.

In channels 1, 2, 4, and 5, bit 2 is reserved. It is always read as 0 and cannot be modified.

Bit 2

TGFC	Description
0	[Clearing conditions] (Initial value) <ul style="list-style-type: none"> When DTC is activated by TGIC interrupt while DISEL bit of MRB in DTC is 0 When 0 is written to TGFC after reading TGFC = 1
1	[Setting conditions] <ul style="list-style-type: none"> When TCNT = TGRC while TGRC is functioning as output compare register When TCNT value is transferred to TGRC by input capture signal while TGRC is functioning as input capture register

Bit 1—Input Capture/Output Compare Flag B (TGFB): Status flag that indicates the occurrence of TGRB input capture or compare match.

Bit 1 TGFB	Description
0	[Clearing conditions] (Initial value) <ul style="list-style-type: none"> • When DTC is activated by TGIB interrupt while DISEL bit of MRB in DTC is 0 • When 0 is written to TGFB after reading TGFB = 1
1	[Setting conditions] <ul style="list-style-type: none"> • When TCNT = TGRB while TGRB is functioning as output compare register • When TCNT value is transferred to TGRB by input capture signal while TGRB is functioning as input capture register

Bit 0—Input Capture/Output Compare Flag A (TGFA): Status flag that indicates the occurrence of TGRA input capture or compare match.

Bit 0 TGFA	Description
0	[Clearing conditions] (Initial value) <ul style="list-style-type: none"> • When DTC is activated by TGIA interrupt while DISEL bit of MRB in DTC is 0 • When 0 is written to TGFA after reading TGFA = 1
1	[Setting conditions] <ul style="list-style-type: none"> • When TCNT = TGRA while TGRA is functioning as output compare register • When TCNT value is transferred to TGRA by input capture signal while TGRA is functioning as input capture register

10.2.6 Timer Counter (TCNT)

Channel 0: TCNT0 (up-counter)

Channel 1: TCNT1 (up/down-counter*)

Channel 2: TCNT2 (up/down-counter*)

Channel 3: TCNT3 (up-counter)

Channel 4: TCNT4 (up/down-counter*)

Channel 5: TCNT5 (up/down-counter*)

Bit	:	15	14	13	12	11	10	9	8	7	6	5	4	3	2	1	0
Initial value :		0	0	0	0	0	0	0	0	0	0	0	0	0	0	0	0
R/W	:	R/W	R/W	R/W	R/W	R/W	R/W	R/W	R/W	R/W	R/W	R/W	R/W	R/W	R/W	R/W	R/W

Note: * These counters can be used as up/down-counters only in phase counting mode or when counting overflow/underflow on another channel. In other cases they function as up-counters.

The TCNT registers are 16-bit counters. The TPU has six TCNT counters, one for each channel.

The TCNT counters are initialized to H'0000 by a reset, and in hardware standby mode.

The TCNT counters cannot be accessed in 8-bit units; they must always be accessed as a 16-bit unit.

10.2.7 Timer General Register (TGR)

Bit	:	15	14	13	12	11	10	9	8	7	6	5	4	3	2	1	0
Initial value :		1	1	1	1	1	1	1	1	1	1	1	1	1	1	1	1
R/W	:	R/W	R/W	R/W	R/W	R/W	R/W	R/W	R/W	R/W	R/W	R/W	R/W	R/W	R/W	R/W	R/W

The TGR registers are 16-bit registers with a dual function as output compare and input capture registers. The TPU has 16 TGR registers, four each for channels 0 and 3 and two each for channels 1, 2, 4, and 5. TGRC and TGRD for channels 0 and 3 can also be designated for operation as buffer registers*. The TGR registers are initialized to H'FFFF by a reset, and in hardware standby mode.

The TGR registers cannot be accessed in 8-bit units; they must always be accessed as a 16-bit unit.

Note: * TGR buffer register combinations are TGRA—TGRC and TGRB—TGRD.

10.2.8 Timer Start Register (TSTR)

Bit	:	7	6	5	4	3	2	1	0
		—	—	CST5	CST4	CST3	CST2	CST1	CST0
Initial value :		0	0	0	0	0	0	0	0
R/W	:	—	—	R/W	R/W	R/W	R/W	R/W	R/W

TSTR is an 8-bit readable/writable register that selects operation/stoppage for channels 0 to 5. TSTR is initialized to H'00 by a reset, and in hardware standby mode. When setting the operating mode in TMDR or setting the count clock in TCR, first stop the TCNT counter.

Bits 7 and 6—Reserved: Should always be written with 0.

Bits 5 to 0—Counter Start 5 to 0 (CST5 to CST0): These bits select operation or stoppage for TCNT.

Bit n CSTn	Description	
0	TCNTn count operation is stopped	(Initial value)
1	TCNTn performs count operation	

n = 5 to 0

Note: If 0 is written to the CST bit during operation with the TIOC pin designated for output, the counter stops but the TIOC pin output compare output level is retained. If TIOR is written to when the CST bit is cleared to 0, the pin output level will be changed to the set initial output value.

10.2.9 Timer Synchro Register (TSYR)

Bit	:	7	6	5	4	3	2	1	0
		—	—	SYNC5	SYNC4	SYNC3	SYNC2	SYNC1	SYNC0
Initial value	:	0	0	0	0	0	0	0	0
R/W	:	—	—	R/W	R/W	R/W	R/W	R/W	R/W

TSYR is an 8-bit readable/writable register that selects independent operation or synchronous operation for the channel 0 to 4 TCNT counters. A channel performs synchronous operation when the corresponding bit in TSYR is set to 1.

TSYR is initialized to H'00 by a reset, and in hardware standby mode.

Bits 7 and 6—Reserved: Should always be written with 0.

Bits 5 to 0—Timer Synchro 5 to 0 (SYNC5 to SYNC0): These bits select whether operation is independent of or synchronized with other channels.

When synchronous operation is selected, synchronous presetting of multiple channels^{*1}, and synchronous clearing through counter clearing on another channel^{*2} are possible.

- Notes: 1. To set synchronous operation, the SYNC bits for at least two channels must be set to 1.
 2. To set synchronous clearing, in addition to the SYNC bit, the TCNT clearing source must also be set by means of bits CCLR2 to CCLR0 in TCR.

Bit n SYNCn	Description
0	TCNTn operates independently (TCNT presetting/clearing is unrelated to other channels) (Initial value)
1	TCNTn performs synchronous operation TCNT synchronous presetting/synchronous clearing is possible

n = 5 to 0

10.2.10 Module Stop Control Register A (MSTPCRA)

Bit	:	7	6	5	4	3	2	1	0
		MSTPA7	MSTPA6	MSTPA5	MSTPA4	MSTPA3	MSTPA2	MSTPA1	MSTPA0
Initial value :		0	0	1	1	1	1	1	1
R/W	:	R/W	R/W	R/W	R/W	R/W	R/W	R/W	R/W

MSTPCRA is an 8-bit readable/writable register that performs module stop mode control.

When the MSTPA5 bit in MSTPCRA is set to 1, TPU operation stops at the end of the bus cycle and a transition is made to module stop mode. Registers cannot be read or written to in module stop mode. For details, see section 23A.5, 23B.5, Module Stop Mode.

MSTPCRA is initialized to H'3F by a reset and in hardware standby mode. It is not initialized in software standby mode.

Bit 5—Module Stop (MSTPA5): Specifies the TPU module stop mode.

Bit 5**MSTPA5 Description**

0	TPU module stop mode cleared	
1	TPU module stop mode set	(Initial value)

10.3 Interface to Bus Master

10.3.1 16-Bit Registers

TCNT and TGR are 16-bit registers. As the data bus to the bus master is 16 bits wide, these registers can be read and written to in 16-bit units.

These registers cannot be read or written to in 8-bit units; 16-bit access must always be used.

An example of 16-bit register access operation is shown in figure 10-2.

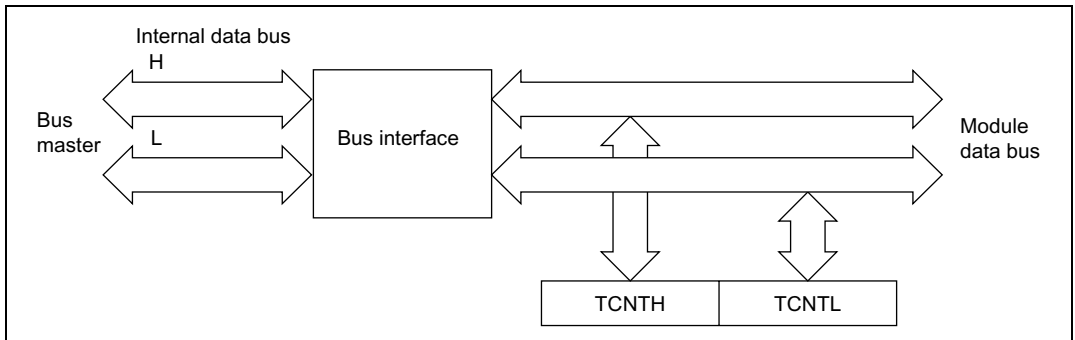

Figure 10-2 16-Bit Register Access Operation [Bus Master ↔ TCNT (16 Bits)]

10.3.2 8-Bit Registers

Registers other than TCNT and TGR are 8-bit. As the data bus to the CPU is 16 bits wide, these registers can be read and written to in 16-bit units. They can also be read and written to in 8-bit units.

Examples of 8-bit register access operation are shown in figures 10-3, 10-4, and 10-5.

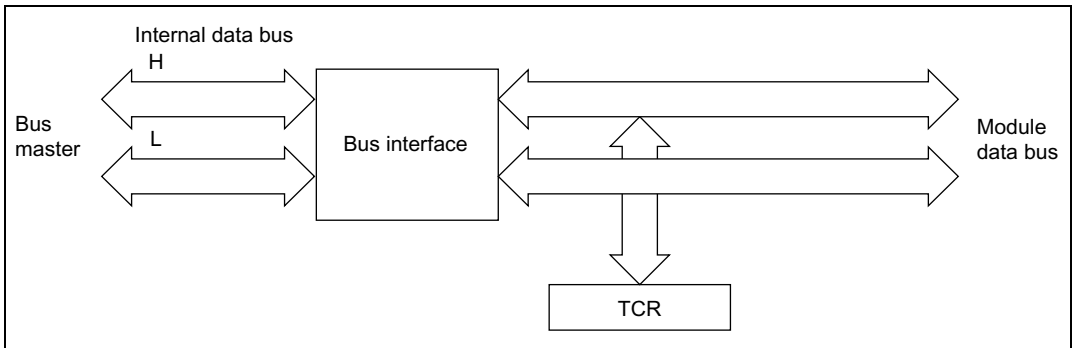

Figure 10-3 8-Bit Register Access Operation [Bus Master ↔ TCR (Upper 8 Bits)]

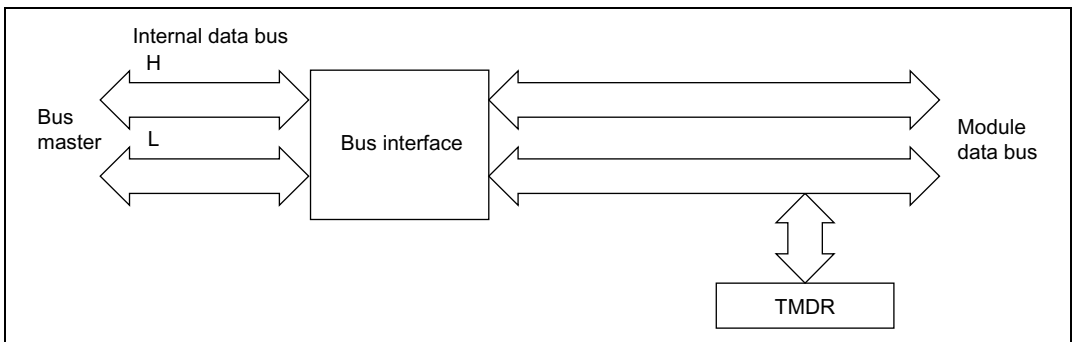

Figure 10-4 8-Bit Register Access Operation [Bus Master ↔ TMDR (Lower 8 Bits)]

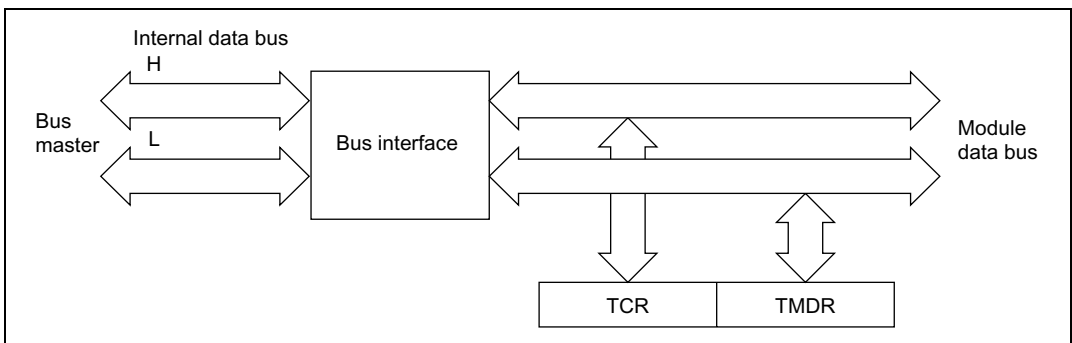

Figure 10-5 8-Bit Register Access Operation [Bus Master ↔ TCR and TMDR (16 Bits)]

10.4 Operation

10.4.1 Overview

Operation in each mode is outlined below.

Normal Operation: Each channel has a TCNT and TGR register. TCNT performs up-counting, and is also capable of free-running operation, synchronous counting, and external event counting.

Each TGR can be used as an input capture register or output compare register.

Synchronous Operation: When synchronous operation is designated for a channel, TCNT for that channel performs synchronous presetting. That is, when TCNT for a channel designated for synchronous operation is rewritten, the TCNT counters for the other channels are also rewritten at the same time. Synchronous clearing of the TCNT counters is also possible by setting the timer synchronization bits in TSYR for channels designated for synchronous operation.

Buffer Operation

- When TGR is an output compare register
When a compare match occurs, the value in the buffer register for the relevant channel is transferred to TGR.
- When TGR is an input capture register
When input capture occurs, the value in TCNT is transfer to TGR and the value previously held in TGR is transferred to the buffer register.

Cascaded Operation: The channel 1 counter (TCNT1), channel 2 counter (TCNT2), channel 4 counter (TCNT4), and channel 5 counter (TCNT5) can be connected together to operate as a 32-bit counter.

PWM Mode: In this mode, a PWM waveform is output. The output level can be set by means of TIOR. A PWM waveform with a duty of between 0% and 100% can be output, according to the setting of each TGR register.

Phase Counting Mode: In this mode, TCNT is incremented or decremented by detecting the phases of two clocks input from the external clock input pins in channels 1, 2, 4, and 5. When phase counting mode is set, the corresponding TCLK pin functions as the clock pin, and TCNT performs up- or down-counting.

This can be used for two-phase encoder pulse input.

10.4.2 Basic Functions

Counter Operation: When one of bits CST0 to CST5 is set to 1 in TSTR, the TCNT counter for the corresponding channel starts counting. TCNT can operate as a free-running counter, periodic counter, and so on.

- Example of count operation setting procedure

Figure 10-6 shows an example of the count operation setting procedure.

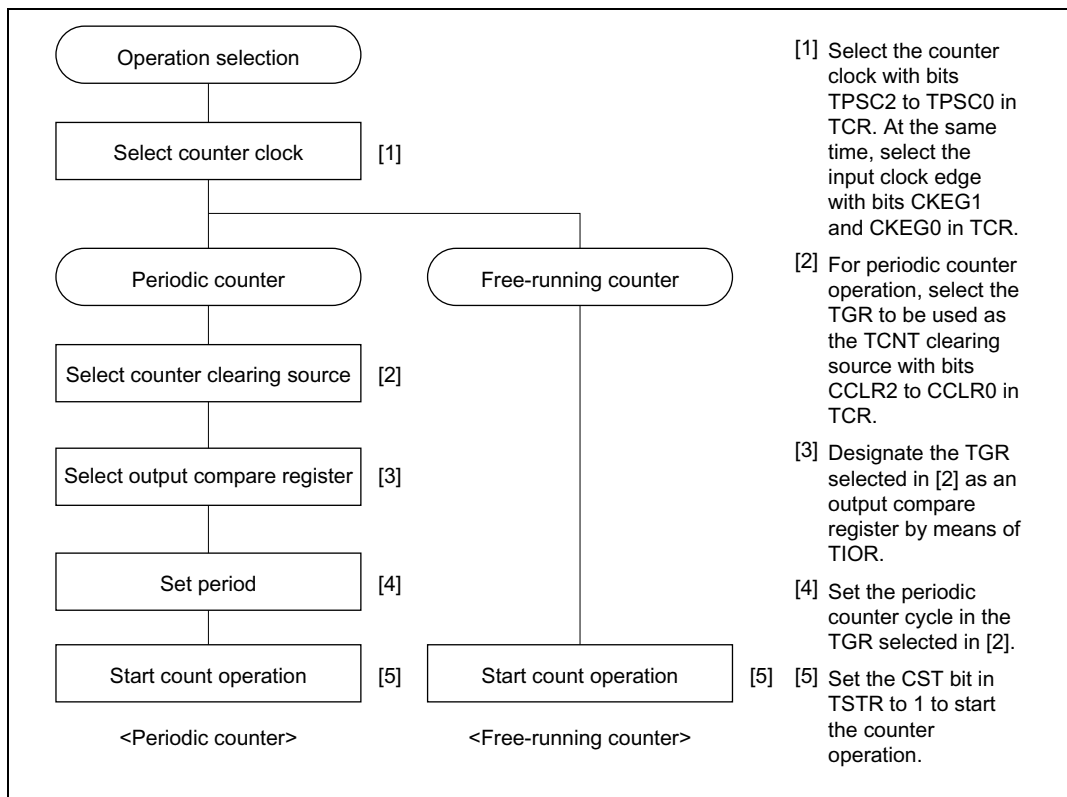

Figure 10-6 Example of Counter Operation Setting Procedure

- Free-running count operation and periodic count operation

Immediately after a reset, the TPU's TCNT counters are all designated as free-running counters. When the relevant bit in TSTR is set to 1 the corresponding TCNT counter starts up-count operation as a free-running counter. When TCNT overflows (from H'FFFF to H'0000), the TCFV bit in TSR is set to 1. If the value of the corresponding TCIEV bit in TIER is 1 at this point, the TPU requests an interrupt. After overflow, TCNT starts counting up again from H'0000.

Figure 10-7 illustrates free-running counter operation.

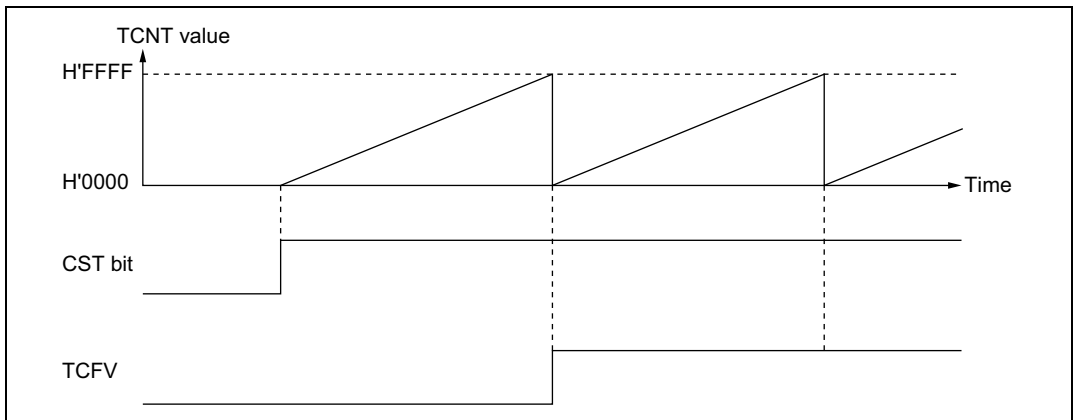

Figure 10-7 Free-Running Counter Operation

When compare match is selected as the TCNT clearing source, the TCNT counter for the relevant channel performs periodic count operation. The TGR register for setting the period is designated as an output compare register, and counter clearing by compare match is selected by means of bits CCLR2 to CCLR0 in TCR. After the settings have been made, TCNT starts up-count operation as periodic counter when the corresponding bit in TSTR is set to 1. When the count value matches the value in TGR, the TGF bit in TSR is set to 1 and TCNT is cleared to H'0000.

If the value of the corresponding TGIE bit in TIER is 1 at this point, the TPU requests an interrupt. After a compare match, TCNT starts counting up again from H'0000.

Figure 10-8 illustrates periodic counter operation.

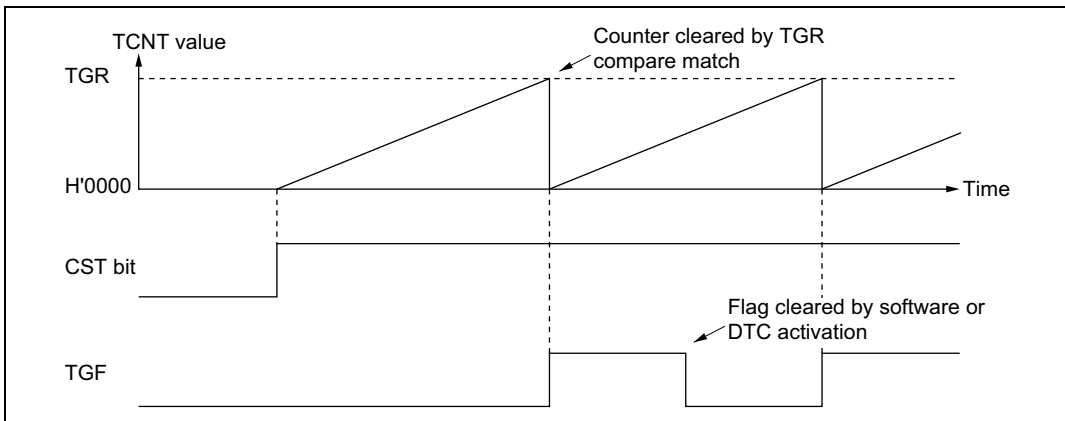

Figure 10-8 Periodic Counter Operation

Waveform Output by Compare Match: The TPU can perform 0, 1, or toggle output from the corresponding output pin using compare match.

- Example of setting procedure for waveform output by compare match

Figure 10-9 shows an example of the setting procedure for waveform output by compare match

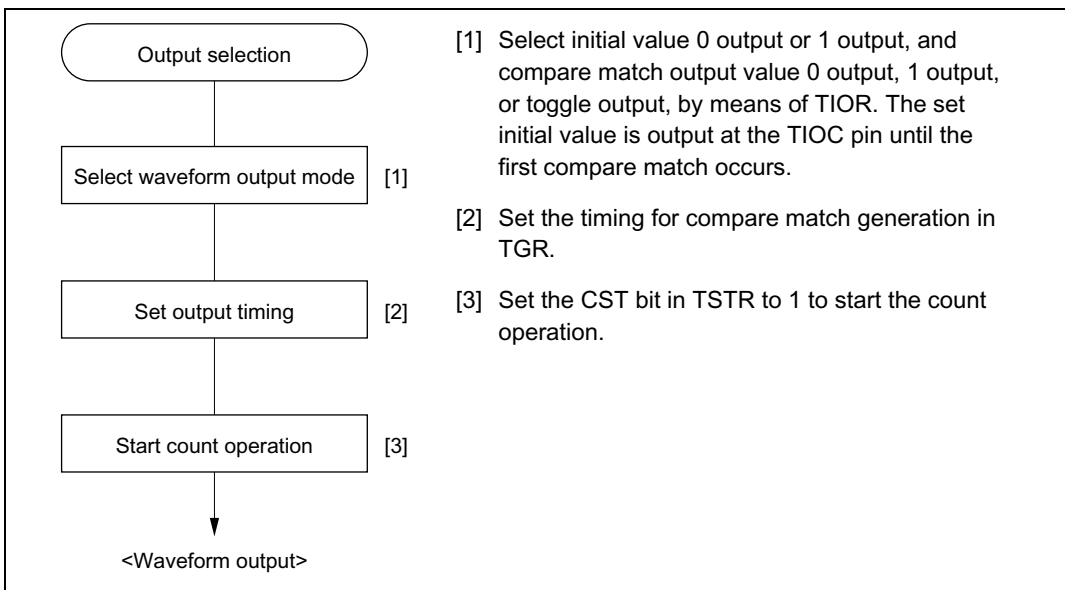

Figure 10-9 Example of Setting Procedure for Waveform Output by Compare Match

- Examples of waveform output operation

Figure 10-10 shows an example of 0 output/1 output.

In this example TCNT has been designated as a free-running counter, and settings have been made so that 1 is output by compare match A, and 0 is output by compare match B. When the set level and the pin level coincide, the pin level does not change.

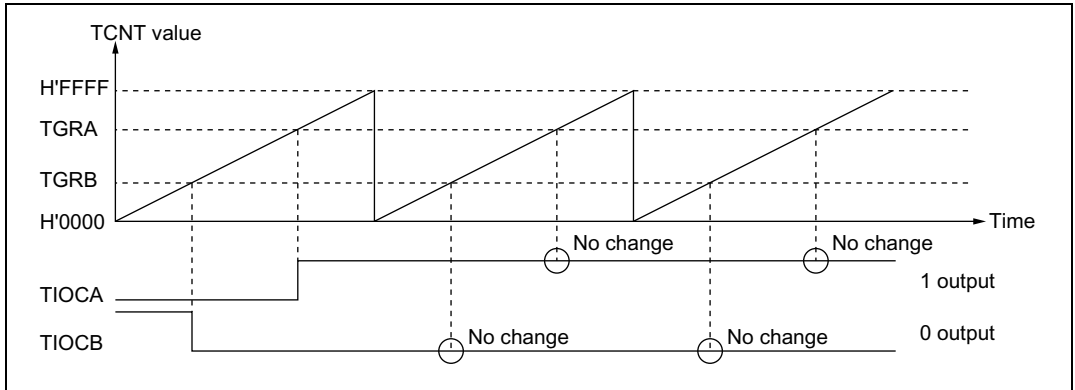

Figure 10-10 Example of 0 Output/1 Output Operation

Figure 10-11 shows an example of toggle output.

In this example TCNT has been designated as a periodic counter (with counter clearing performed by compare match B), and settings have been made so that output is toggled by both compare match A and compare match B.

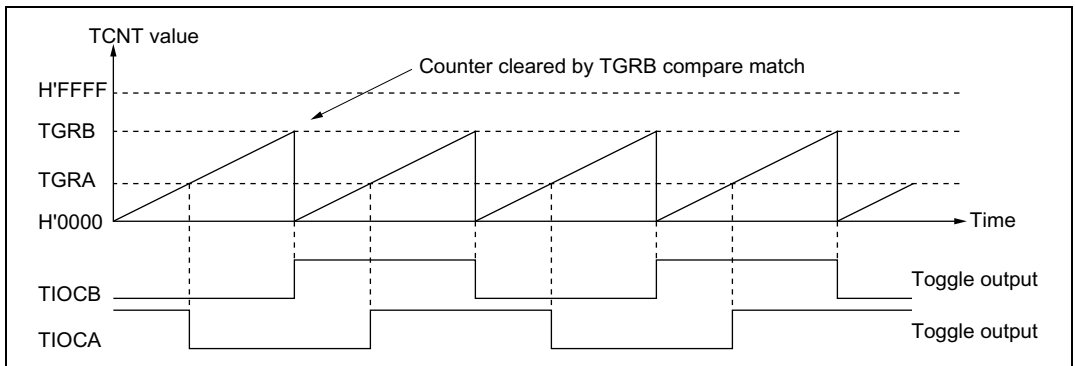

Figure 10-11 Example of Toggle Output Operation

Input Capture Function: The TCNT value can be transferred to TGR on detection of the TIOC pin input edge.

Rising edge, falling edge, or both edges can be selected as the detected edge. For channels 0, 1, 3, and 4, it is also possible to specify another channel's counter input clock or compare match signal as the input capture source.

Note: When another channel's counter input clock is used as the input capture input for channels 0 and 3, $\phi/1$ should not be selected as the counter input clock used for input capture input. Input capture will not be generated if $\phi/1$ is selected.

- Example of input capture operation setting procedure

Figure 10-12 shows an example of the input capture operation setting procedure.

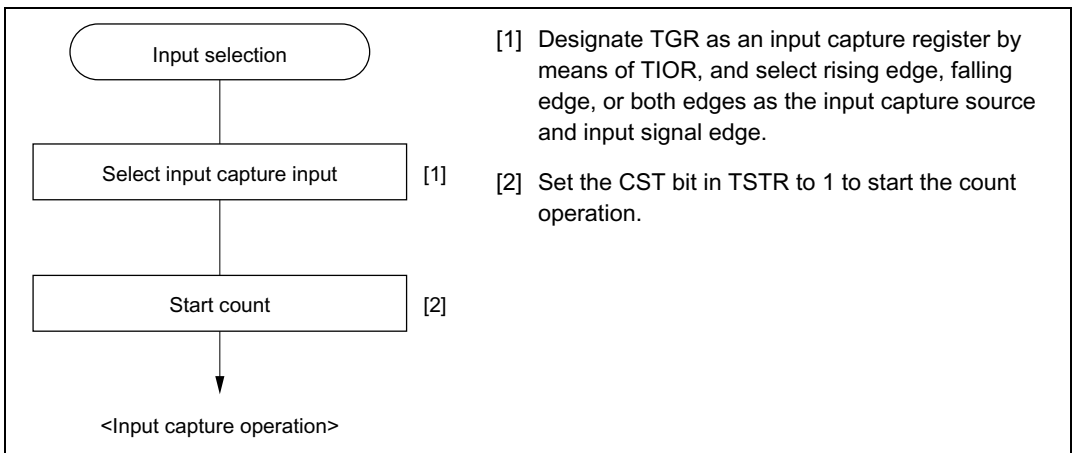

Figure 10-12 Example of Input Capture Operation Setting Procedure

- Example of input capture operation

Figure 10-13 shows an example of input capture operation.

In this example both rising and falling edges have been selected as the TIOCA pin input capture input edge, falling edge has been selected as the TIOCB pin input capture input edge, and counter clearing by TGRB input capture has been designated for TCNT.

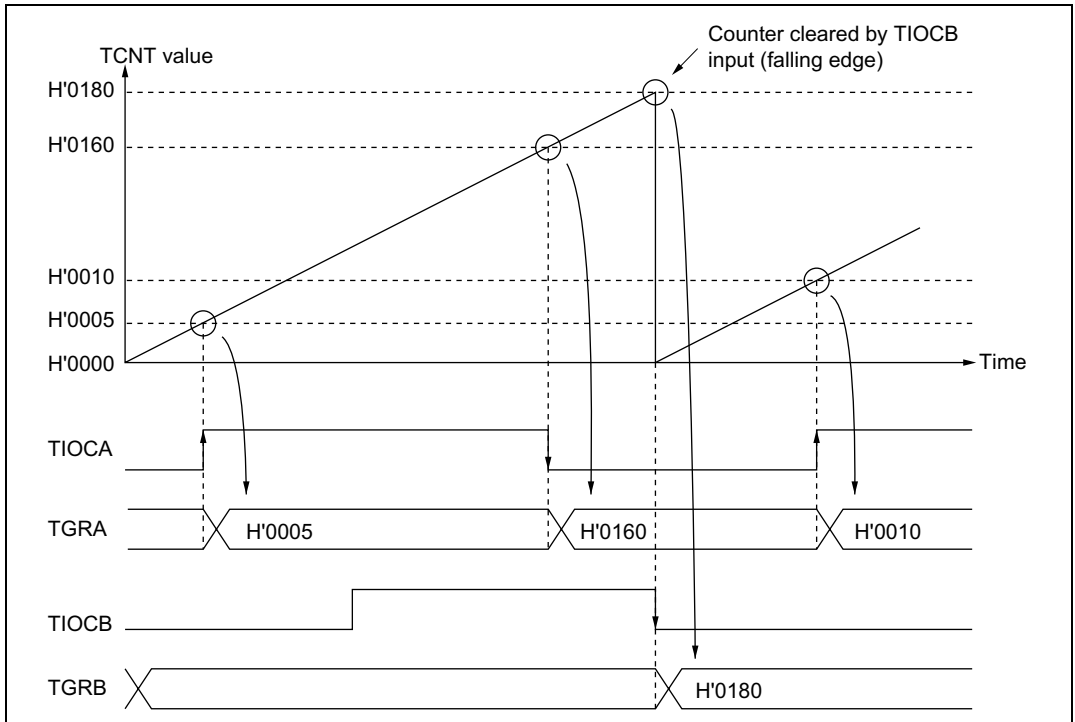

Figure 10-13 Example of Input Capture Operation

10.4.3 Synchronous Operation

In synchronous operation, the values in a number of TCNT counters can be rewritten simultaneously (synchronous presetting). Also, a number of TCNT counters can be cleared simultaneously by making the appropriate setting in TCR (synchronous clearing).

Synchronous operation enables TGR to be incremented with respect to a single time base.

Channels 0 to 5 can all be designated for synchronous operation.

Example of Synchronous Operation Setting Procedure: Figure 10-14 shows an example of the synchronous operation setting procedure.

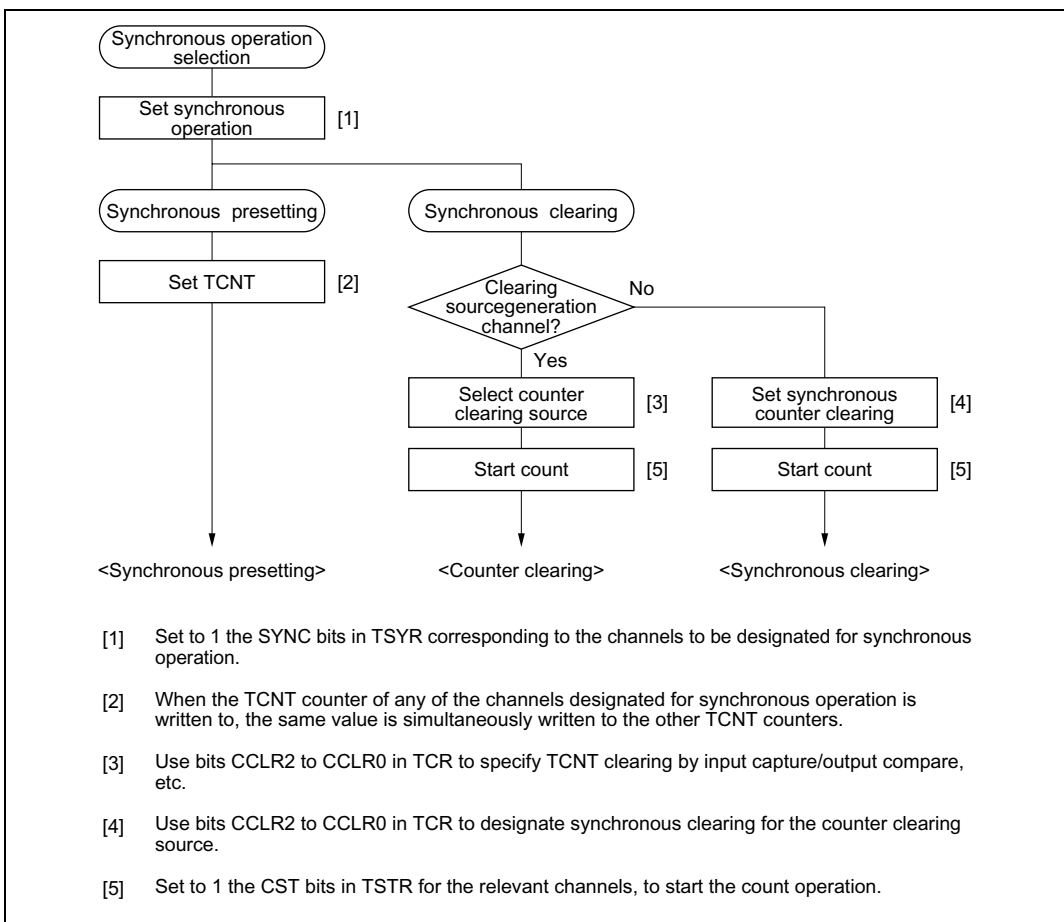

Figure 10-14 Example of Synchronous Operation Setting Procedure

Example of Synchronous Operation: Figure 10-15 shows an example of synchronous operation.

In this example, synchronous operation and PWM mode 1 have been designated for channels 0 to 2, TGR0B compare match has been set as the channel 0 counter clearing source, and synchronous clearing has been set for the channel 1 and 2 counter clearing source.

Three-phase PWM waveforms are output from pins TIOC0A, TIOC1A, and TIOC2A. At this time, synchronous presetting, and synchronous clearing by TGR0B compare match, is performed for channel 0 to 2 TCNT counters, and the data set in TGR0B is used as the PWM cycle.

For details of PWM modes, see section 10.4.6, PWM Modes.

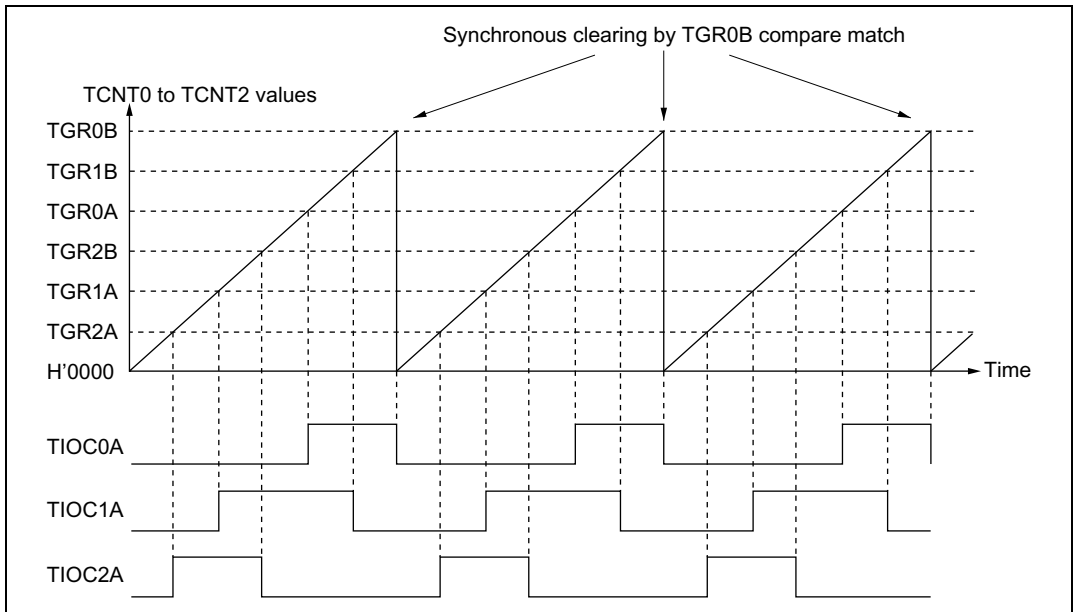

Figure 10-15 Example of Synchronous Operation

10.4.4 Buffer Operation

Buffer operation, provided for channels 0 and 3, enables TGRC and TGRD to be used as buffer registers.

Buffer operation differs depending on whether TGR has been designated as an input capture register or as a compare match register.

Table 10-5 shows the register combinations used in buffer operation.

Table 10-5 Register Combinations in Buffer Operation

Channel	Timer General Register	Buffer Register
0	TGR0A	TGR0C
	TGR0B	TGR0D
3	TGR3A	TGR3C
	TGR3B	TGR3D

- When TGR is an output compare register

When a compare match occurs, the value in the buffer register for the corresponding channel is transferred to the timer general register.

This operation is illustrated in figure 10-16.

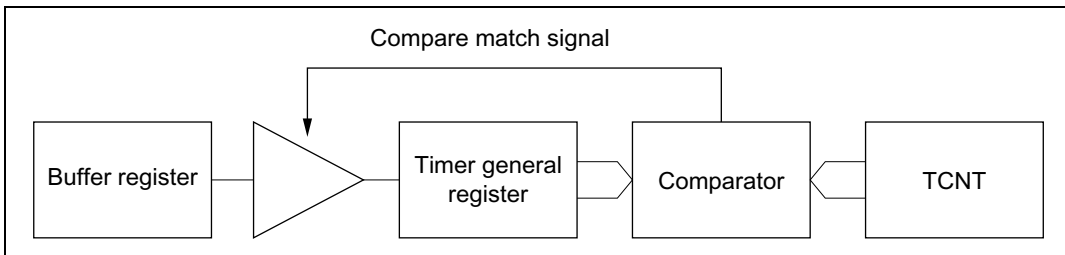

Figure 10-16 Compare Match Buffer Operation

- When TGR is an input capture register

When input capture occurs, the value in TCNT is transferred to TGR and the value previously held in the timer general register is transferred to the buffer register.

This operation is illustrated in figure 10-17.

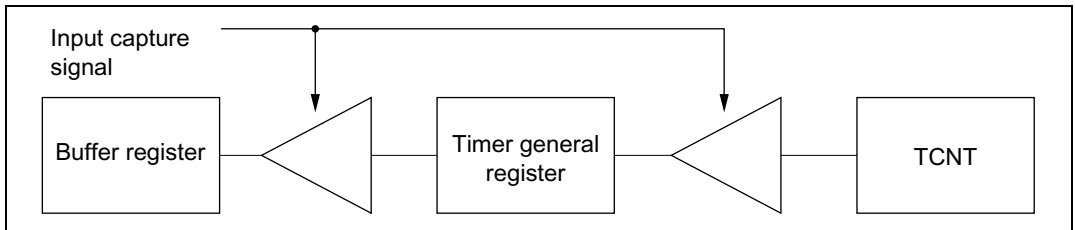

Figure 10-17 Input Capture Buffer Operation

Example of Buffer Operation Setting Procedure: Figure 10-18 shows an example of the buffer operation setting procedure.

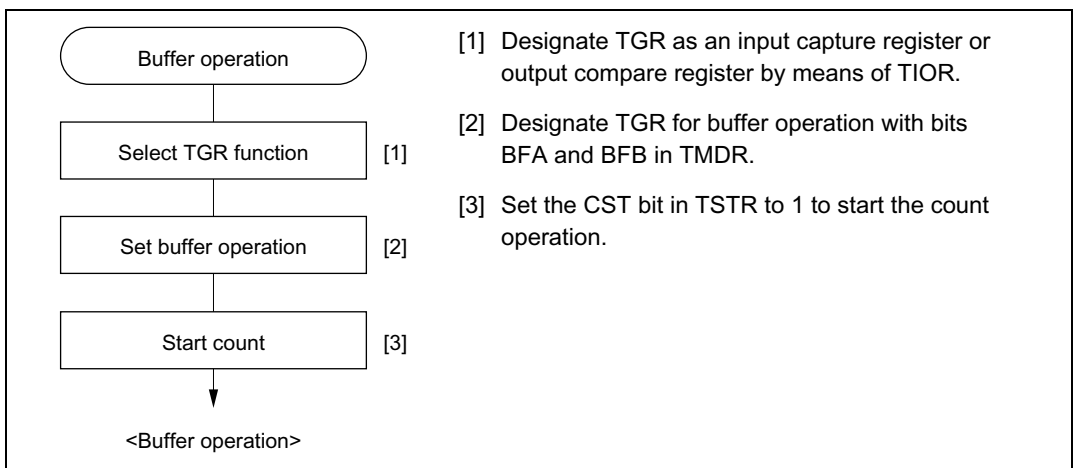

Figure 10-18 Example of Buffer Operation Setting Procedure

Examples of Buffer Operation

- When TGR is an output compare register

Figure 10-19 shows an operation example in which PWM mode 1 has been designated for channel 0, and buffer operation has been designated for TGRA and TGRC. The settings used in this example are TCNT clearing by compare match B, 1 output at compare match A, and 0 output at compare match B.

As buffer operation has been set, when compare match A occurs the output changes and the value in buffer register TGRC is simultaneously transferred to timer general register TGRA. This operation is repeated each time compare match A occurs.

For details of PWM modes, see section 10.4.6, PWM Modes.

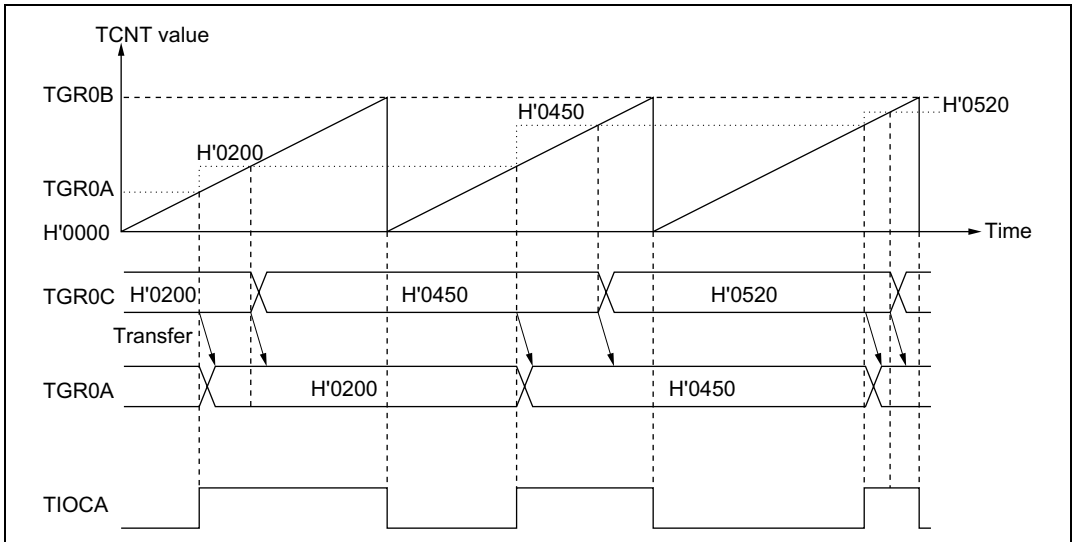

Figure 10-19 Example of Buffer Operation (1)

- When TGR is an input capture register

Figure 10-20 shows an operation example in which TGRA has been designated as an input capture register, and buffer operation has been designated for TGRA and TGRC.

Counter clearing by TGRA input capture has been set for TCNT, and both rising and falling edges have been selected as the TIOCA pin input capture input edge.

As buffer operation has been set, when the TCNT value is stored in TGRA upon occurrence of input capture A, the value previously stored in TGRA is simultaneously transferred to TGRC.

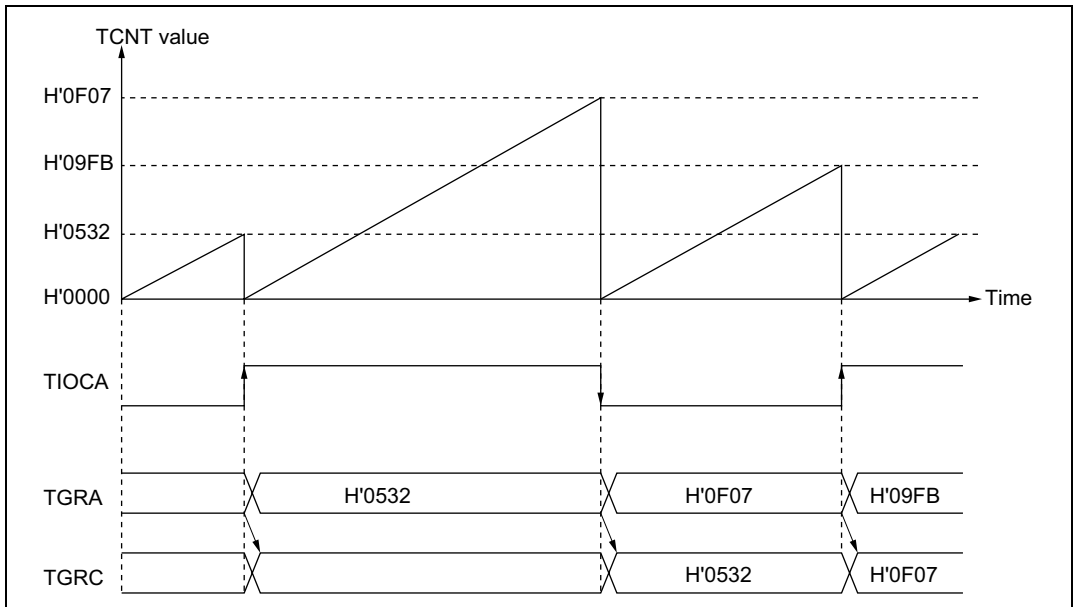

Figure 10-20 Example of Buffer Operation (2)

10.4.5 Cascaded Operation

In cascaded operation, two 16-bit counters for different channels are used together as a 32-bit counter.

This function works by counting the channel 1 (channel 4) counter clock upon overflow/underflow of TCNT2 (TCNT5) as set in bits TPSC2 to TPSC0 in TCR.

Underflow occurs only when the lower 16-bit TCNT is in phase-counting mode.

Table 10-6 shows the register combinations used in cascaded operation.

Note: When phase counting mode is set for channel 1 or 4, the counter clock setting is invalid and the counter operates independently in phase counting mode.

Table 10-6 Cascaded Combinations

Combination	Upper 16 Bits	Lower 16 Bits
Channels 1 and 2	TCNT1	TCNT2
Channels 4 and 5	TCNT4	TCNT5

Example of Cascaded Operation Setting Procedure: Figure 10-21 shows an example of the setting procedure for cascaded operation.

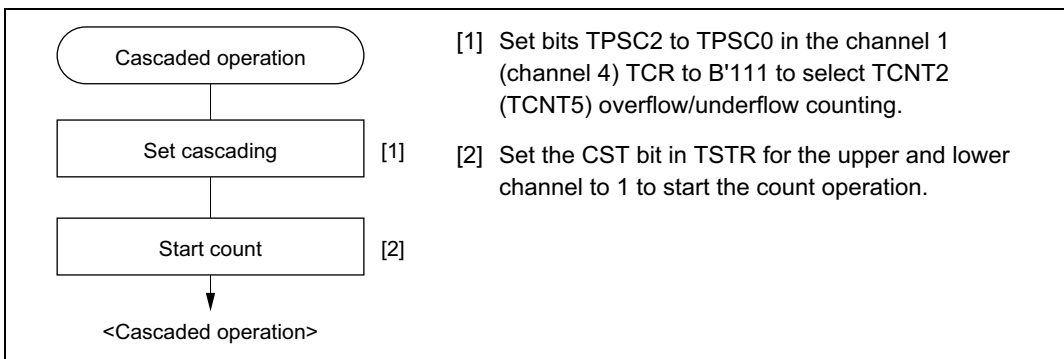

Figure 10-21 Cascaded Operation Setting Procedure

Examples of Cascaded Operation: Figure 10-22 illustrates the operation when counting upon TCNT2 overflow/underflow has been set for TCNT1, TGR1A, and TGR2A have been designated as input capture registers, and TIOC pin rising edge has been selected.

When a rising edge is input to the TIOCA1 and TIOCA2 pins simultaneously, the upper 16 bits of the 32-bit data are transferred to TGR1A, and the lower 16 bits to TGR2A.

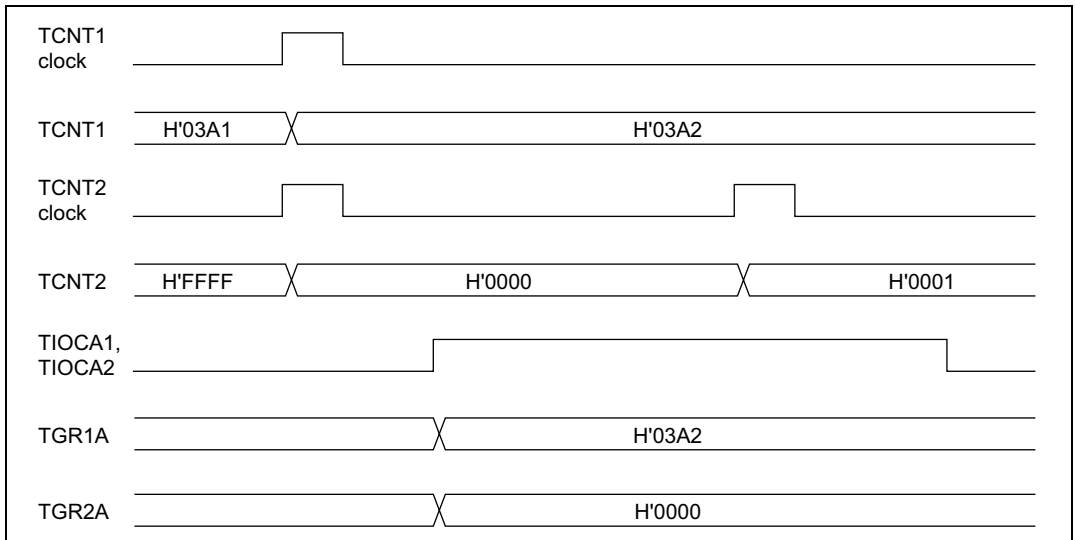

Figure 10-22 Example of Cascaded Operation (1)

Figure 10-23 illustrates the operation when counting upon TCNT2 overflow/underflow has been set for TCNT1, and phase counting mode has been designated for channel 2.

TCNT1 is incremented by TCNT2 overflow and decremented by TCNT2 underflow.

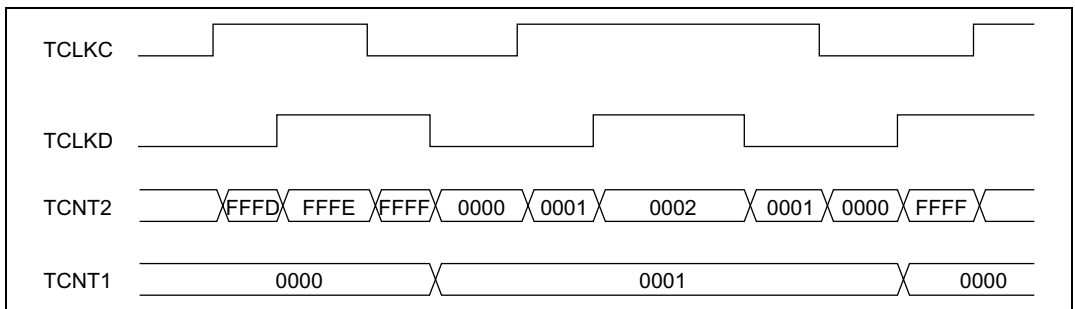

Figure 10-23 Example of Cascaded Operation (2)

10.4.6 PWM Modes

In PWM mode, PWM waveforms are output from the output pins. 0, 1, or toggle output can be selected as the output level in response to compare match of each TGR.

Designating TGR compare match as the counter clearing source enables the period to be set in that register. All channels can be designated for PWM mode independently. Synchronous operation is also possible.

There are two PWM modes, as described below.

- PWM mode 1

PWM output is generated from the TIOCA and TIOCC pins by pairing TGRA with TGRB and TGRC with TGRD. The output specified by bits IOA3 to IOA0 and IOC3 to IOC0 in TIOR is output from the TIOCA and TIOCC pins at compare matches A and C, and the output specified by bits IOB3 to IOB0 and IOD3 to IOD0 in TIOR is output at compare matches B and D. The initial output value is the value set in TGRA or TGRC. If the set values of paired TGRs are identical, the output value does not change when a compare match occurs.

In PWM mode 1, a maximum 8-phase PWM output is possible.

- PWM mode 2

PWM output is generated using one TGR as the cycle register and the others as duty registers. The output specified in TIOR is performed by means of compare matches. Upon counter clearing by a synchronization register compare match, the output value of each pin is the initial value set in TIOR. If the set values of the cycle and duty registers are identical, the output value does not change when a compare match occurs.

In PWM mode 2, a maximum 15-phase PWM output is possible by combined use with synchronous operation.

The correspondence between PWM output pins and registers is shown in table 10-7.

Table 10-7 PWM Output Registers and Output Pins

Channel	Registers	Output Pins	
		PWM Mode 1	PWM Mode 2
0	TGR0A	TIOCA0	TIOCA0
	TGR0B		TIOCB0
	TGR0C	TIOCC0	TIOCC0
	TGR0D		TIOCD0
1	TGR1A	TIOCA1	TIOCA1
	TGR1B		TIOCB1
2	TGR2A	TIOCA2	TIOCA2
	TGR2B		TIOCB2
3	TGR3A	TIOCA3	TIOCA3
	TGR3B		TIOCB3
	TGR3C	TIOCC3	TIOCC3
	TGR3D		TIOCD3
4	TGR4A	TIOCA4	TIOCA4
	TGR4B		TIOCB4
5	TGR5A	TIOCA5	TIOCA5
	TGR5B		TIOCB5

Note: In PWM mode 2, PWM output is not possible for the TGR register in which the period is set.

Example of PWM Mode Setting Procedure: Figure 10-24 shows an example of the PWM mode setting procedure.

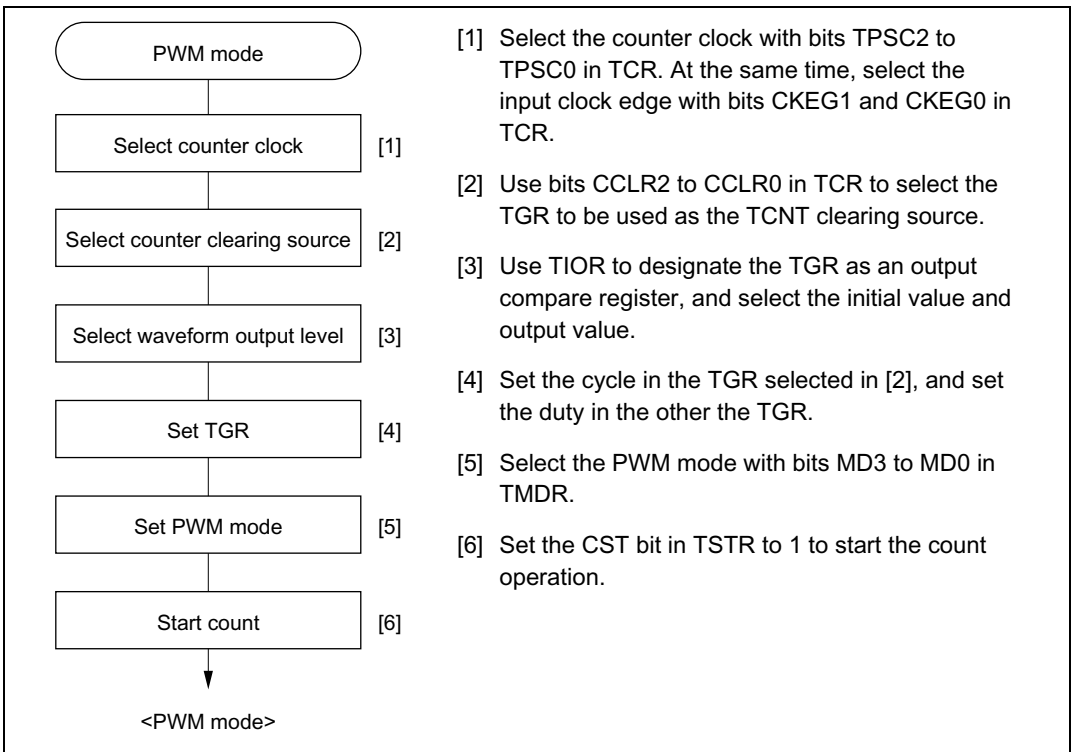

Figure 10-24 Example of PWM Mode Setting Procedure

Examples of PWM Mode Operation: Figure 10-25 shows an example of PWM mode 1 operation.

In this example, TGRA compare match is set as the TCNT clearing source, 0 is set for the TGRA initial output value and output value, and 1 is set as the TGRB output value.

In this case, the value set in TGRA is used as the period, and the values set in TGRB registers as the duty.

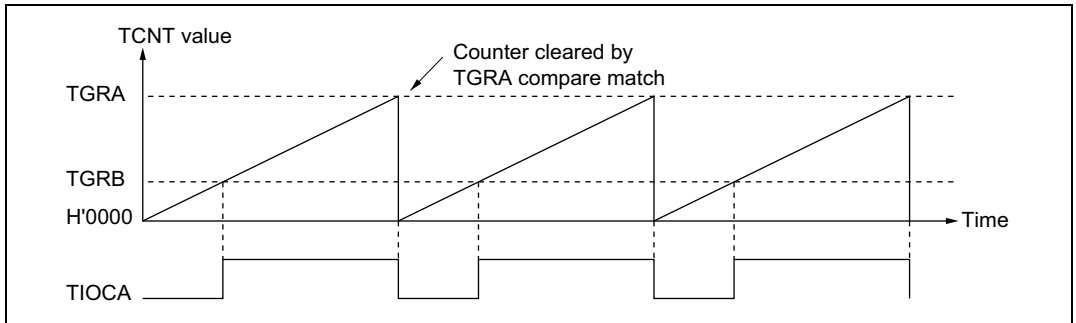

Figure 10-25 Example of PWM Mode Operation (1)

Figure 10-26 shows an example of PWM mode 2 operation.

In this example, synchronous operation is designated for channels 0 and 1, TGR1B compare match is set as the TCNT clearing source, and 0 is set for the initial output value and 1 for the output value of the other TGR registers (TGR0A to TGR0D, TGR1A), to output a 5-phase PWM waveform.

In this case, the value set in TGR1B is used as the cycle, and the values set in the other TGRs as the duty.

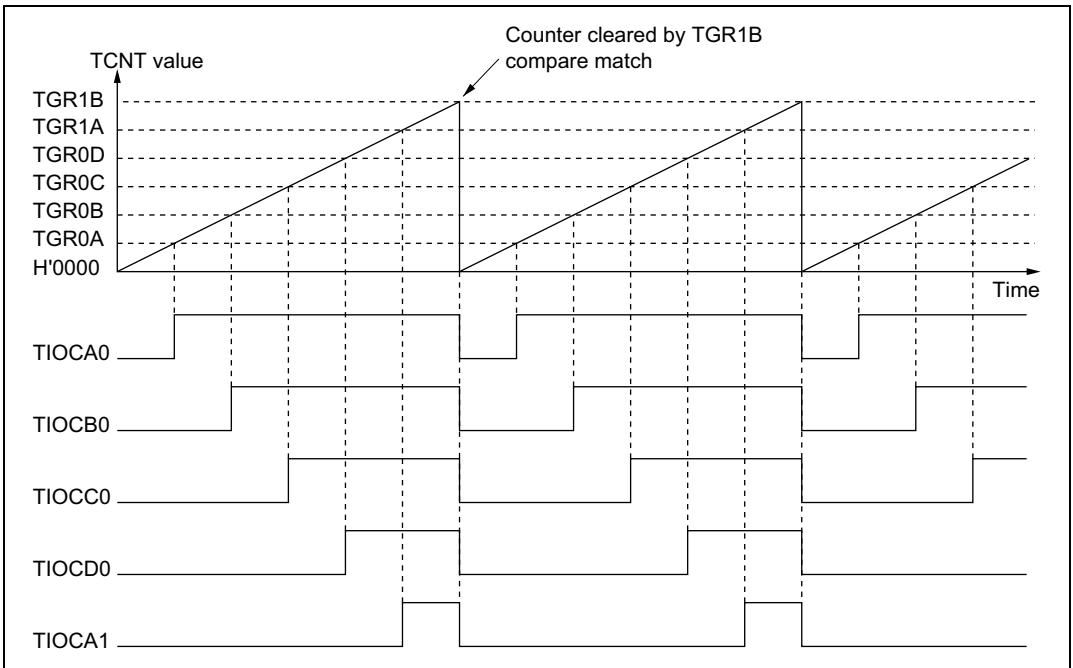

Figure 10-26 Example of PWM Mode Operation (2)

Figure 10-27 shows examples of PWM waveform output with 0% duty and 100% duty in PWM mode.

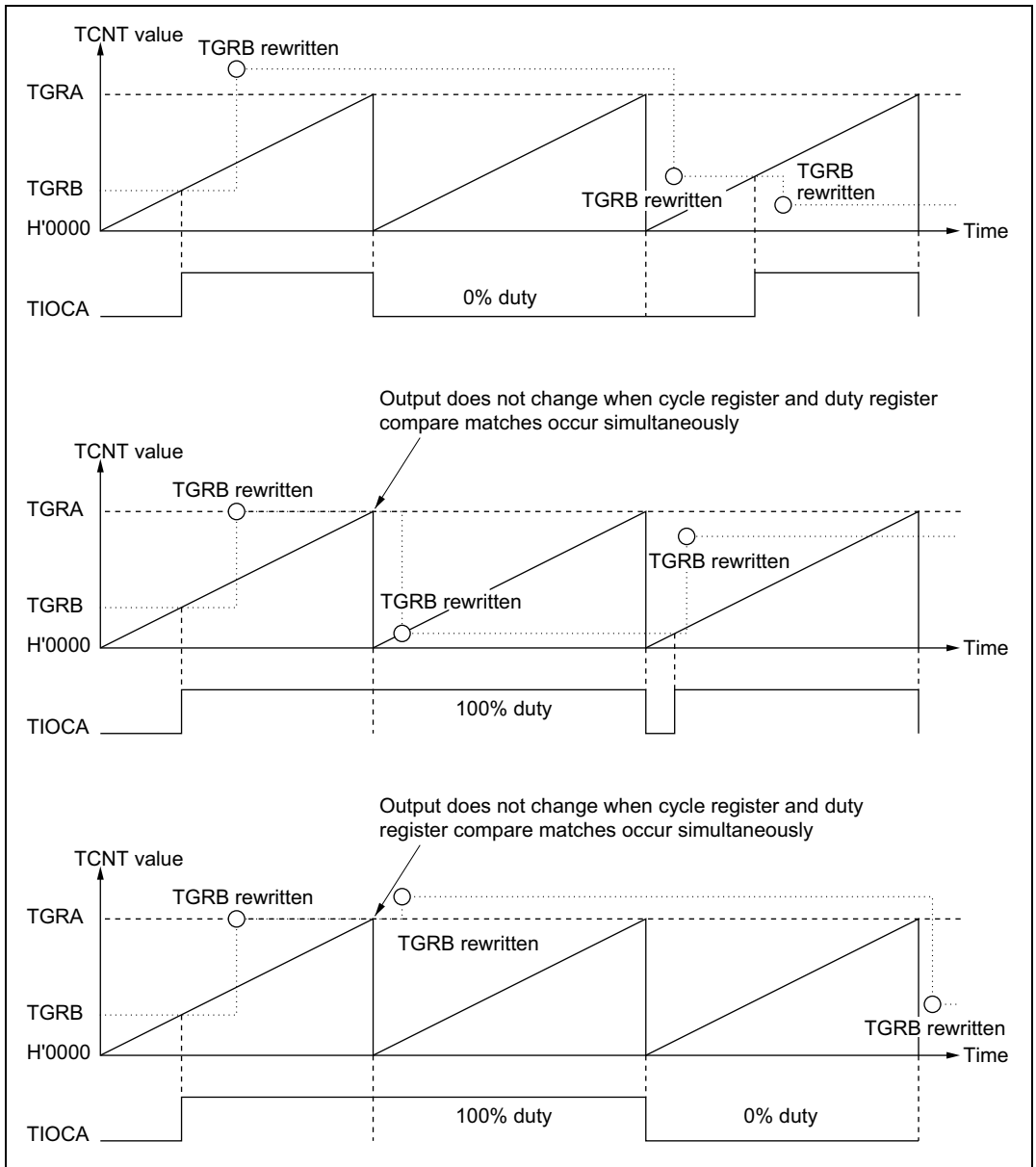

Figure 10-27 Example of PWM Mode Operation (3)

10.4.7 Phase Counting Mode

In phase counting mode, the phase difference between two external clock inputs is detected and TCNT is incremented/decremented accordingly. This mode can be set for channels 1, 2, 4, and 5.

When phase counting mode is set, an external clock is selected as the counter input clock and TCNT operates as an up/down-counter regardless of the setting of bits TPSC2 to TPSC0 and bits CKEG1 and CKEG0 in TCR. However, the functions of bits CCLR1 and CCLR0 in TCR, and of TIOR, TIER, and TGR are valid, and input capture/compare match and interrupt functions can be used.

When overflow occurs while TCNT is counting up, the TCFV flag in TSR is set; when underflow occurs while TCNT is counting down, the TCFU flag is set.

The TCFD bit in TSR is the count direction flag. Reading the TCFD flag provides an indication of whether TCNT is counting up or down.

Table 10-8 shows the correspondence between external clock pins and channels.

Table 10-8 Phase Counting Mode Clock Input Pins

Channels	External Clock Pins	
	A-Phase	B-Phase
When channel 1 or 5 is set to phase counting mode	TCLKA	TCLKB
When channel 2 or 4 is set to phase counting mode	TCLKC	TCLKD

Example of Phase Counting Mode Setting Procedure: Figure 10-28 shows an example of the phase counting mode setting procedure.

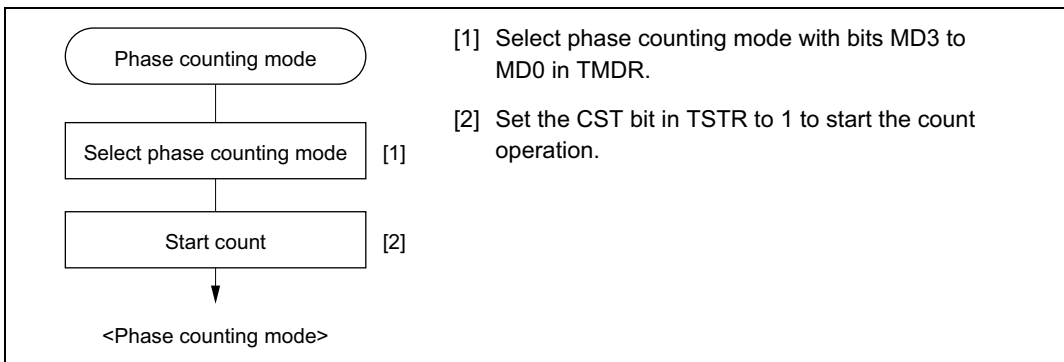

Figure 10-28 Example of Phase Counting Mode Setting Procedure

Examples of Phase Counting Mode Operation: In phase counting mode, TCNT counts up or down according to the phase difference between two external clocks. There are four modes, according to the count conditions.

- Phase counting mode 1

Figure 10-29 shows an example of phase counting mode 1 operation, and table 10-9 summarizes the TCNT up/down-count conditions.

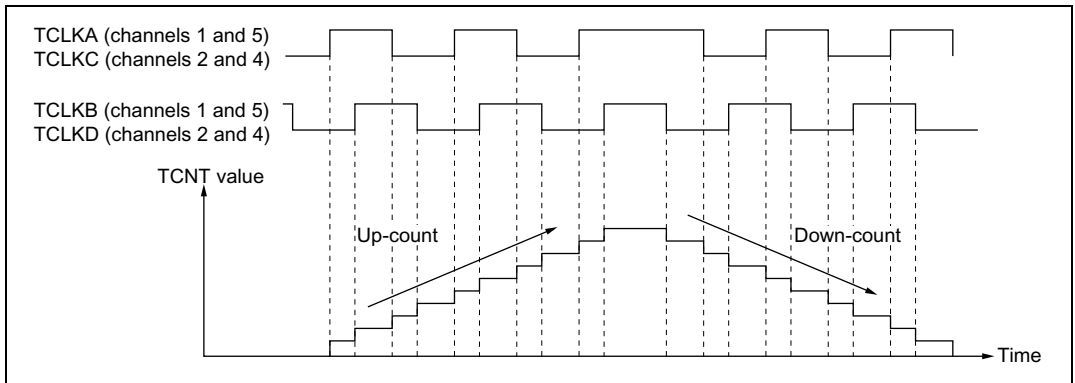

Figure 10-29 Example of Phase Counting Mode 1 Operation

Table 10-9 Up/Down-Count Conditions in Phase Counting Mode 1

TCLKA (Channels 1 and 5) TCLKC (Channels 2 and 4)	TCLKB (Channels 1 and 5) TCLKD (Channels 2 and 4)	Operation
High level		Up-count
Low level		
	Low level	
	High level	
High level		Down-count
Low level		
	High level	
	Low level	

Legend:

: Rising edge
 : Falling edge

- Phase counting mode 2

Figure 10-30 shows an example of phase counting mode 2 operation, and table 10-10 summarizes the TCNT up/down-count conditions.

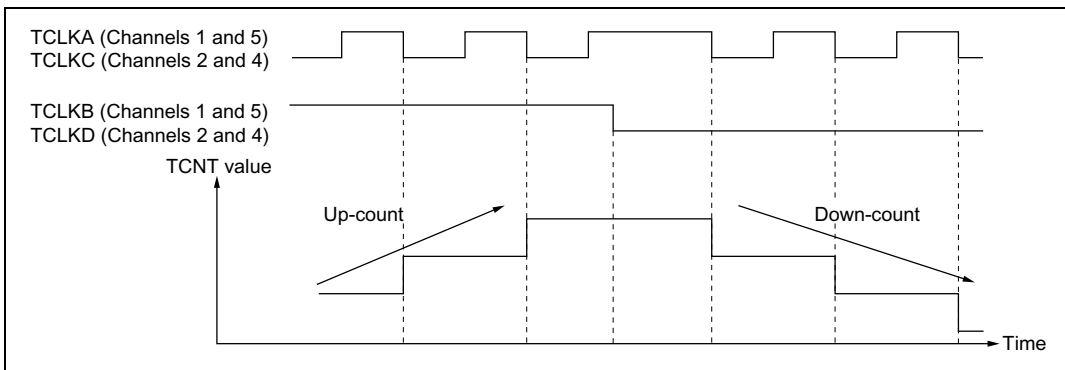

Figure 10-30 Example of Phase Counting Mode 2 Operation

Table 10-10 Up/Down-Count Conditions in Phase Counting Mode 2

TCLKA (Channels 1 and 5) TCLKC (Channels 2 and 4)	TCLKB (Channels 1 and 5) TCLKD (Channels 2 and 4)	Operation
High level		Don't care
Low level		Don't care
	Low level	Don't care
	High level	Up-count
High level		Don't care
Low level		Don't care
	High level	Don't care
	Low level	Down-count

Legend:

: Rising edge
 : Falling edge

- Phase counting mode 3

Figure 10-31 shows an example of phase counting mode 3 operation, and table 10-11 summarizes the TCNT up/down-count conditions.

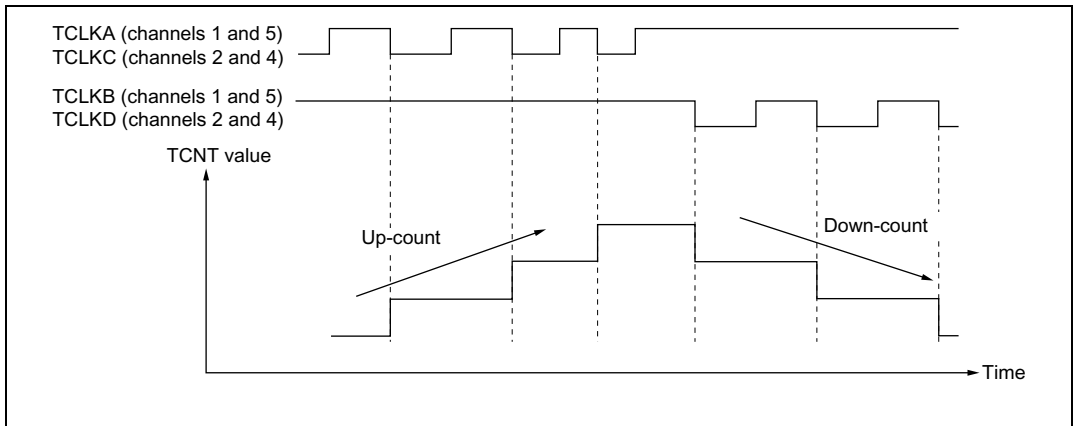

Figure 10-31 Example of Phase Counting Mode 3 Operation

Table 10-11 Up/Down-Count Conditions in Phase Counting Mode 3

TCLKA (Channels 1 and 5) TCLKC (Channels 2 and 4)	TCLKB (Channels 1 and 5) TCLKD (Channels 2 and 4)	Operation
High level		Don't care
Low level		Don't care
	Low level	Don't care
	High level	Up-count
High level		Down-count
Low level		Don't care
	High level	Don't care
	Low level	Don't care

Legend:

: Rising edge
 : Falling edge

- Phase counting mode 4

Figure 10-32 shows an example of phase counting mode 4 operation, and table 10-12 summarizes the TCNT up/down-count conditions.

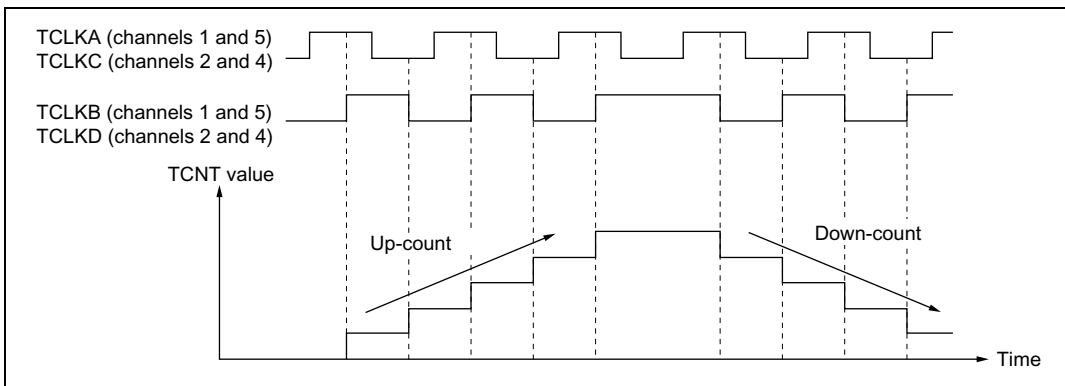

Figure 10-32 Example of Phase Counting Mode 4 Operation

Table 10-12 Up/Down-Count Conditions in Phase Counting Mode 4

TCLKA (Channels 1 and 5) TCLKC (Channels 2 and 4)	TCLKB (Channels 1 and 5) TCLKD (Channels 2 and 4)	Operation
High level		Up-count
Low level		Up-count
	Low level	Don't care
	High level	Don't care
High level		Down-count
Low level		Down-count
	High level	Don't care
	Low level	Don't care

Legend:

: Rising edge
 : Falling edge

Phase Counting Mode Application Example: Figure 10-33 shows an example in which phase counting mode is designated for channel 1, and channel 1 is coupled with channel 0 to input servo motor 2-phase encoder pulses in order to detect the position or speed.

Channel 1 is set to phase counting mode 1, and the encoder pulse A-phase and B-phase are input to TCLKA and TCLKB.

Channel 0 operates with TCNT counter clearing by TGR0C compare match; TGR0A and TGR0C are used for the compare match function, and are set with the speed control period and position control period. TGR0B is used for input capture, with TGR0B and TGR0D operating in buffer mode. The channel 1 counter input clock is designated as the TGR0B input capture source, and detection of the pulse width of 2-phase encoder 4-multiplication pulses is performed.

TGR1A and TGR1B for channel 1 are designated for input capture, channel 0 TGR0A and TGR0C compare matches are selected as the input capture source, and store the up/down-counter values for the control periods.

This procedure enables accurate position/speed detection to be achieved.

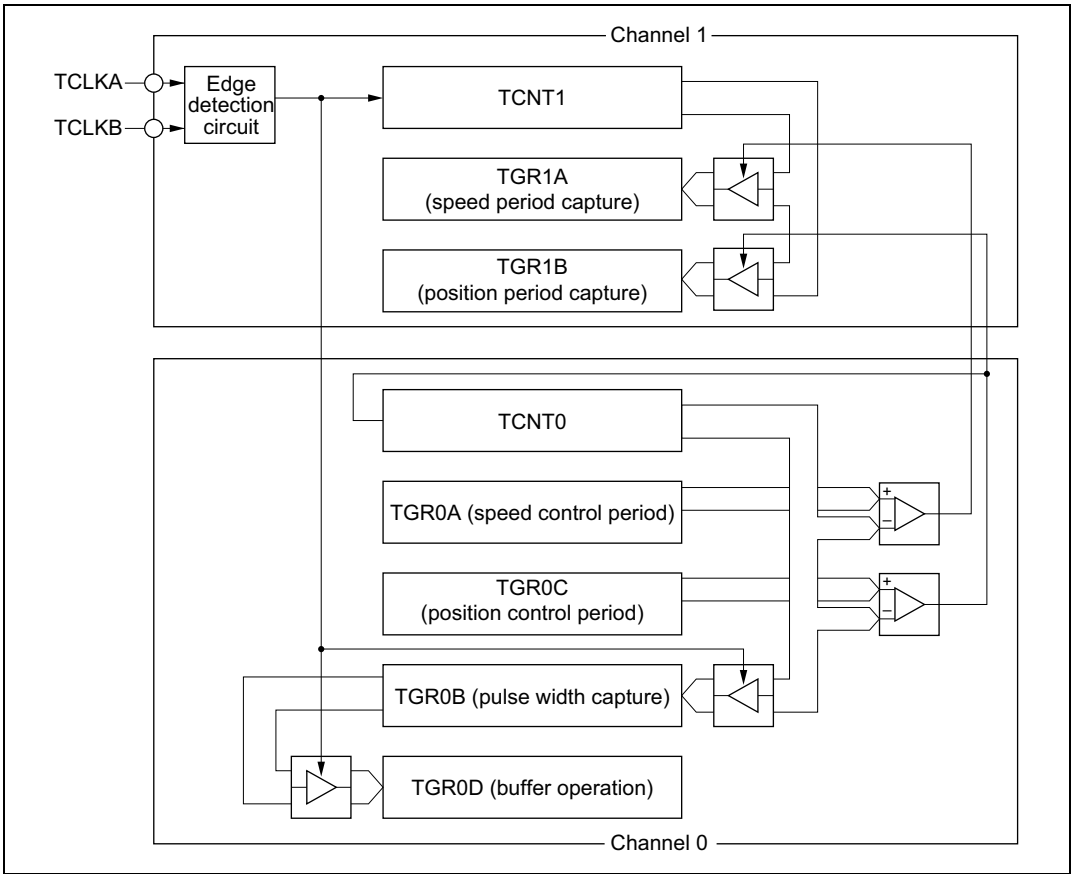

Figure 10-33 Phase Counting Mode Application Example

10.5 Interrupts

10.5.1 Interrupt Sources and Priorities

There are three kinds of TPU interrupt source: TGR input capture/compare match, TCNT overflow, and TCNT underflow. Each interrupt source has its own status flag and enable/disabled bit, allowing generation of interrupt request signals to be enabled or disabled individually.

When an interrupt request is generated, the corresponding status flag in TSR is set to 1. If the corresponding enable/disable bit in TIER is set to 1 at this time, an interrupt is requested. The interrupt request is cleared by clearing the status flag to 0.

Relative channel priorities can be changed by the interrupt controller, but the priority order within a channel is fixed. For details, see section 5, Interrupt Controller.

Table 10-13 lists the TPU interrupt sources.

Table 10-13 TPU Interrupts

Channel	Interrupt Source	Description	DTC Activation	Priority
0	TGI0A	TGR0A input capture/compare match	Possible	High ↑ Low
	TGI0B	TGR0B input capture/compare match	Possible	
	TGI0C	TGR0C input capture/compare match	Possible	
	TGI0D	TGR0D input capture/compare match	Possible	
	TCI0V	TCNT0 overflow	Not possible	
1	TGI1A	TGR1A input capture/compare match	Possible	
	TGI1B	TGR1B input capture/compare match	Possible	
	TCI1V	TCNT1 overflow	Not possible	
	TCI1U	TCNT1 underflow	Not possible	
2	TGI2A	TGR2A input capture/compare match	Possible	
	TGI2B	TGR2B input capture/compare match	Possible	
	TCI2V	TCNT2 overflow	Not possible	
	TCI2U	TCNT2 underflow	Not possible	
3	TGI3A	TGR3A input capture/compare match	Possible	
	TGI3B	TGR3B input capture/compare match	Possible	
	TGI3C	TGR3C input capture/compare match	Possible	
	TGI3D	TGR3D input capture/compare match	Possible	
	TCI3V	TCNT3 overflow	Not possible	
4	TGI4A	TGR4A input capture/compare match	Possible	
	TGI4B	TGR4B input capture/compare match	Possible	
	TCI4V	TCNT4 overflow	Not possible	
	TCI4U	TCNT4 underflow	Not possible	
5	TGI5A	TGR5A input capture/compare match	Possible	
	TGI5B	TGR5B input capture/compare match	Possible	
	TCI5V	TCNT5 overflow	Not possible	
	TCI5U	TCNT5 underflow	Not possible	

Note: This table shows the initial state immediately after a reset. The relative channel priorities can be changed by the interrupt controller.

Input Capture/Compare Match Interrupt: An interrupt is requested if the TGIE bit in TIER is set to 1 when the TGF flag in TSR is set to 1 by the occurrence of a TGR input capture/compare match on a particular channel. The interrupt request is cleared by clearing the TGF flag to 0. The TPU has 16 input capture/compare match interrupts, four each for channels 0 and 3, and two each for channels 1, 2, 4, and 5.

Overflow Interrupt: An interrupt is requested if the TCIEV bit in TIER is set to 1 when the TCFV flag in TSR is set to 1 by the occurrence of TCNT overflow on a channel. The interrupt request is cleared by clearing the TCFV flag to 0. The TPU has six overflow interrupts, one for each channel.

Underflow Interrupt: An interrupt is requested if the TCIEU bit in TIER is set to 1 when the TCFU flag in TSR is set to 1 by the occurrence of TCNT underflow on a channel. The interrupt request is cleared by clearing the TCFU flag to 0. The TPU has four underflow interrupts, one each for channels 1, 2, 4, and 5.

10.5.2 DTC Activation

Note: The DTC is not implemented in the H8S/2635 and H8S/2634.

DTC Activation: The DTC can be activated by the TGR input capture/compare match interrupt for a channel. For details, see section 8, Data Transfer Controller (DTC).

A total of 16 TPU input capture/compare match interrupts can be used as DTC activation sources, four each for channels 0 and 3, and two each for channels 1, 2, 4, and 5.

10.5.3 A/D Converter Activation

The A/D converter can be activated by the TGRA input capture/compare match for a channel.

If the TTGE bit in TIER is set to 1 when the TGFA flag in TSR is set to 1 by the occurrence of a TGRA input capture/compare match on a particular channel, a request to start A/D conversion is sent to the A/D converter. If the TPU conversion start trigger has been selected on the A/D converter side at this time, A/D conversion is started.

In the TPU, a total of six TGRA input capture/compare match interrupts can be used as A/D converter conversion start sources, one for each channel.

10.6 Operation Timing

10.6.1 Input/Output Timing

TCNT Count Timing: Figure 10-34 shows TCNT count timing in internal clock operation, and figure 10-35 shows TCNT count timing in external clock operation.

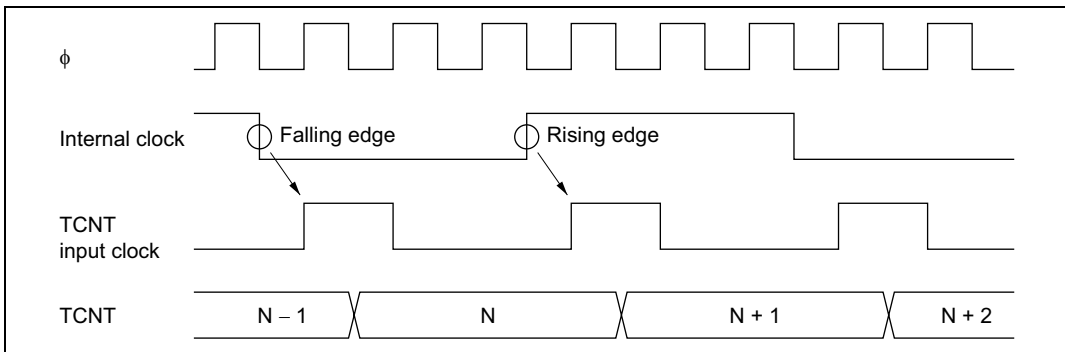

Figure 10-34 Count Timing in Internal Clock Operation

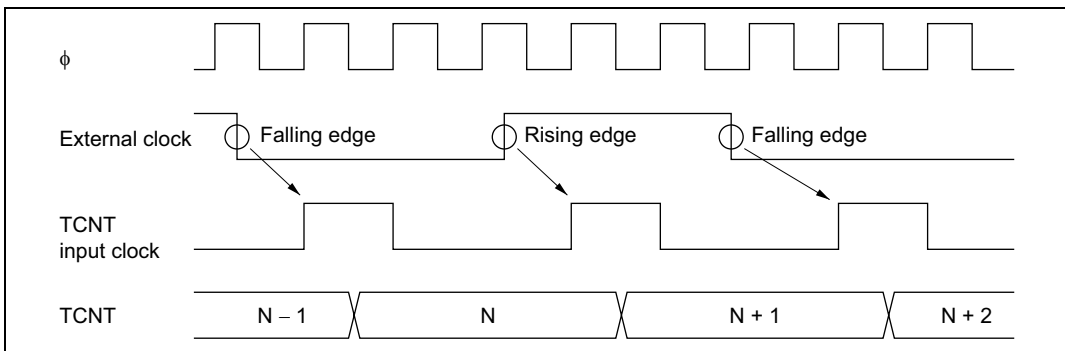

Figure 10-35 Count Timing in External Clock Operation

Output Compare Output Timing: A compare match signal is generated in the final state in which TCNT and TGR match (the point at which the count value matched by TCNT is updated). When a compare match signal is generated, the output value set in TIOR is output at the output compare output pin. After a match between TCNT and TGR, the compare match signal is not generated until the TCNT input clock is generated.

Figure 10-36 shows output compare output timing.

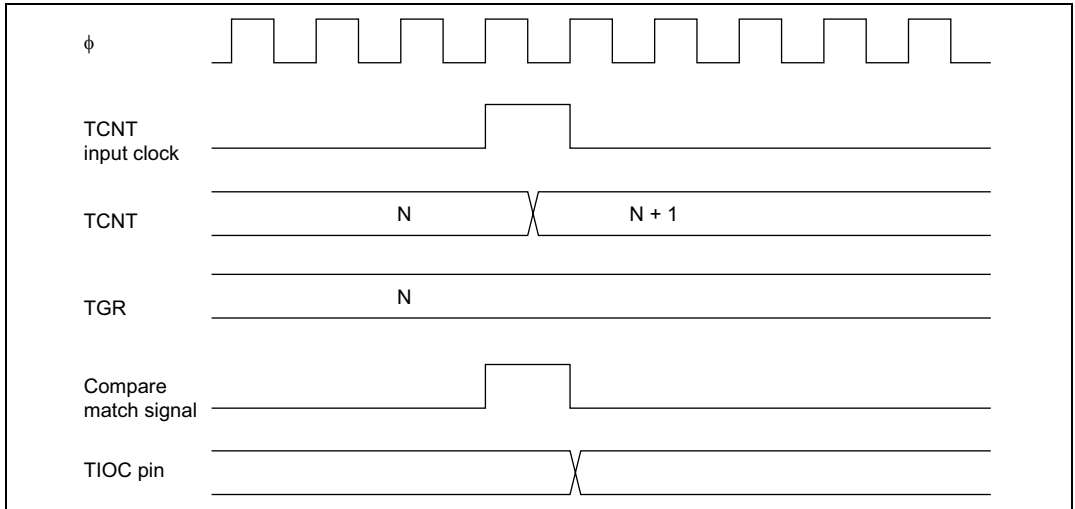

Figure 10-36 Output Compare Output Timing

Input Capture Signal Timing: Figure 10-37 shows input capture signal timing.

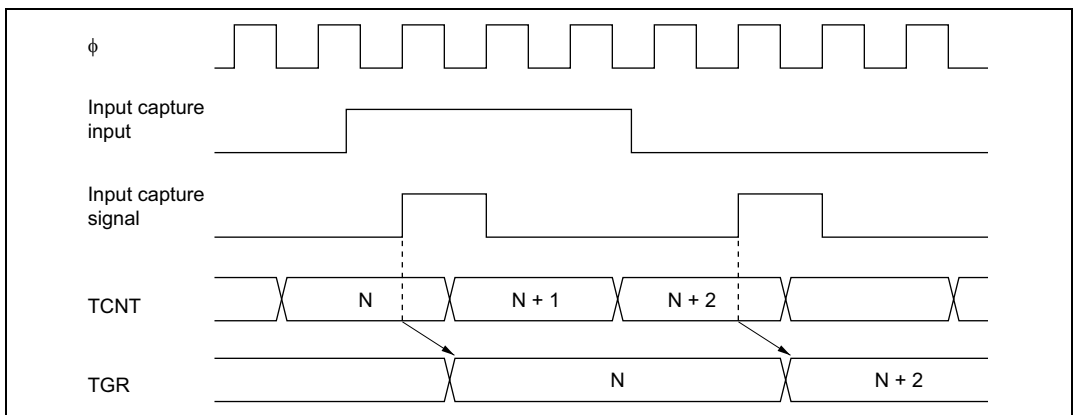

Figure 10-37 Input Capture Input Signal Timing

Timing for Counter Clearing by Compare Match/Input Capture: Figure 10-38 shows the timing when counter clearing by compare match occurrence is specified, and figure 10-39 shows the timing when counter clearing by input capture occurrence is specified.

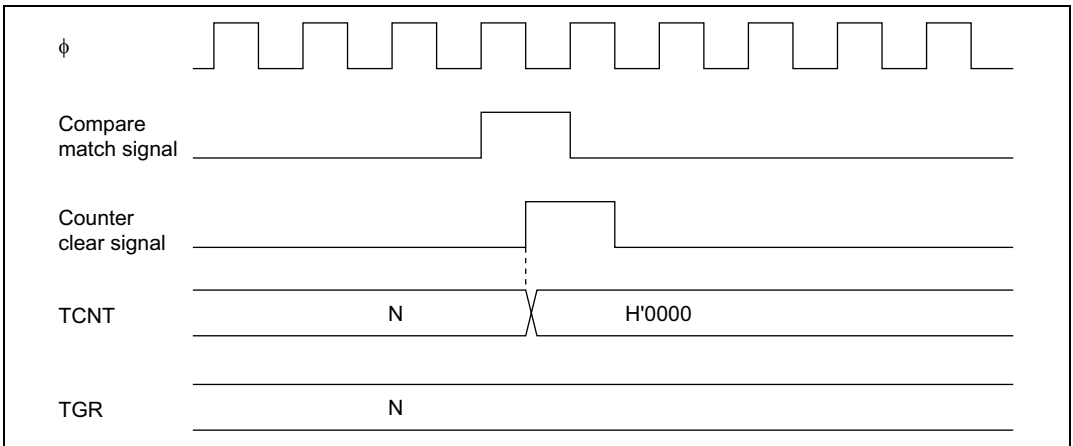

Figure 10-38 Counter Clear Timing (Compare Match)

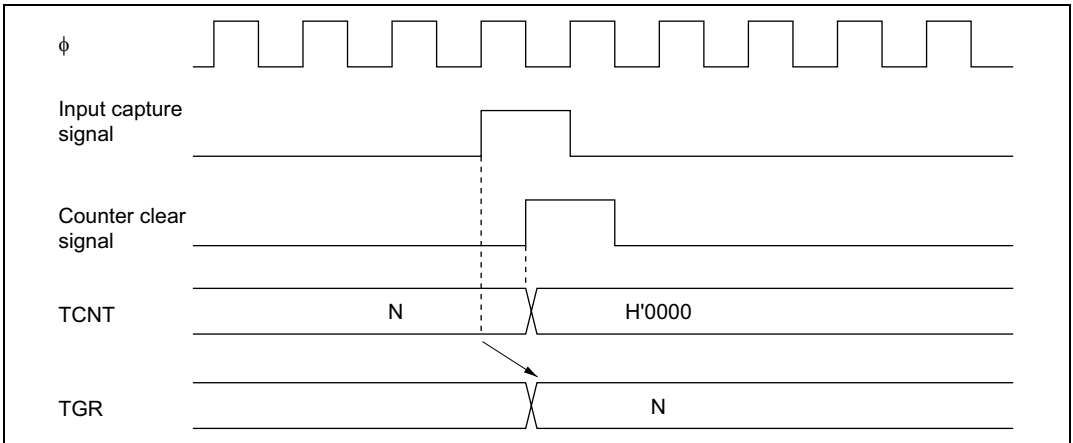

Figure 10-39 Counter Clear Timing (Input Capture)

Buffer Operation Timing: Figures 10-40 and 10-41 show the timing in buffer operation.

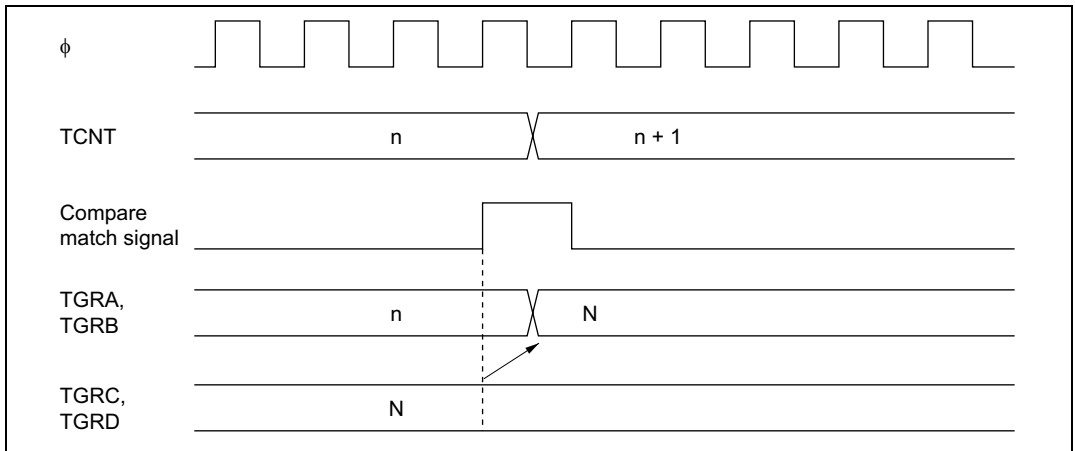

Figure 10-40 Buffer Operation Timing (Compare Match)

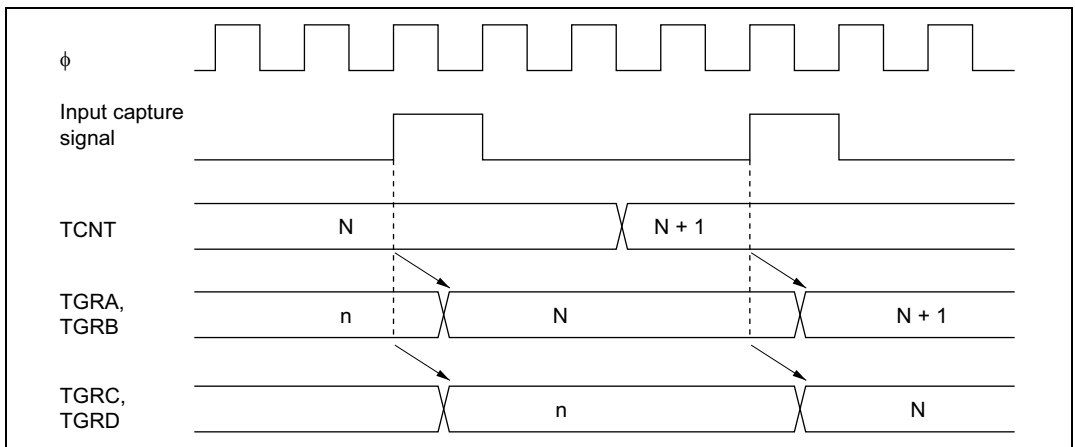

Figure 10-41 Buffer Operation Timing (Input Capture)

10.6.2 Interrupt Signal Timing

TGF Flag Setting Timing in Case of Compare Match: Figure 10-42 shows the timing for setting of the TGF flag in TSR by compare match occurrence, and TGI interrupt request signal timing.

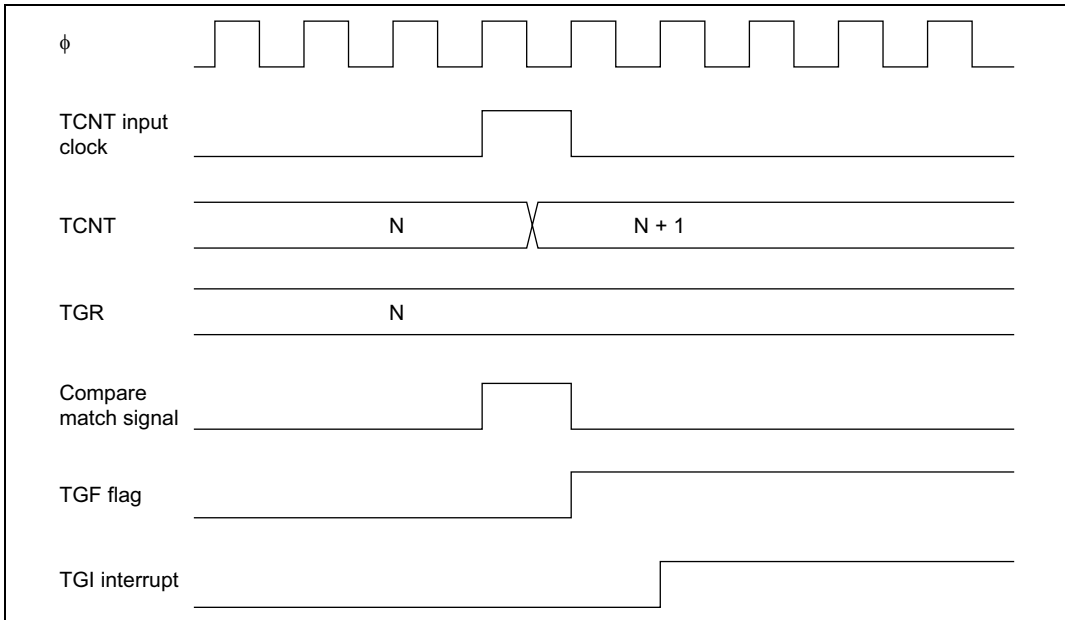

Figure 10-42 TGI Interrupt Timing (Compare Match)

TGF Flag Setting Timing in Case of Input Capture: Figure 10-43 shows the timing for setting of the TGF flag in TSR by input capture occurrence, and TGI interrupt request signal timing.

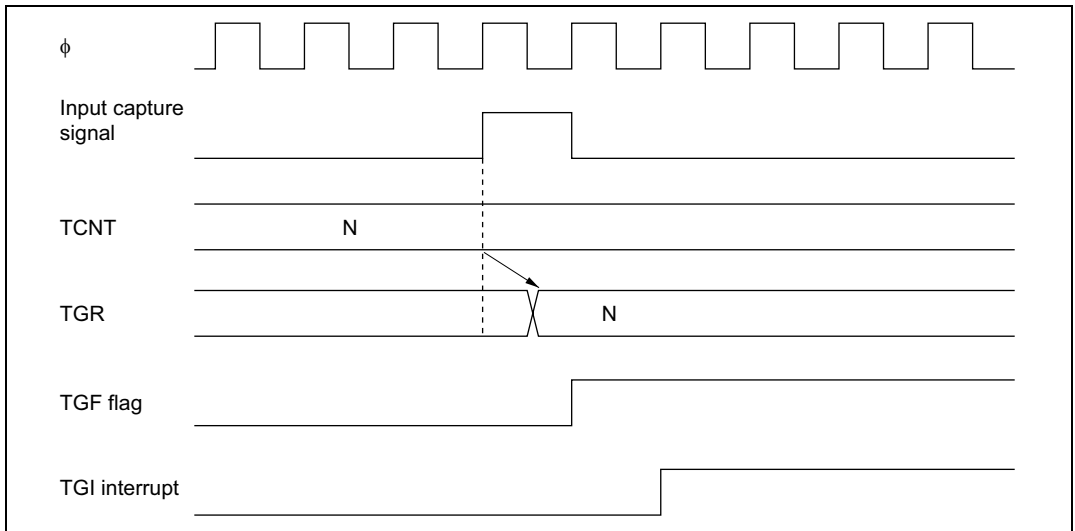

Figure 10-43 TGI Interrupt Timing (Input Capture)

TCFV Flag/TCFU Flag Setting Timing: Figure 10-44 shows the timing for setting of the TCFV flag in TSR by overflow occurrence, and TCIV interrupt request signal timing.

Figure 10-45 shows the timing for setting of the TCFU flag in TSR by underflow occurrence, and TCIU interrupt request signal timing.

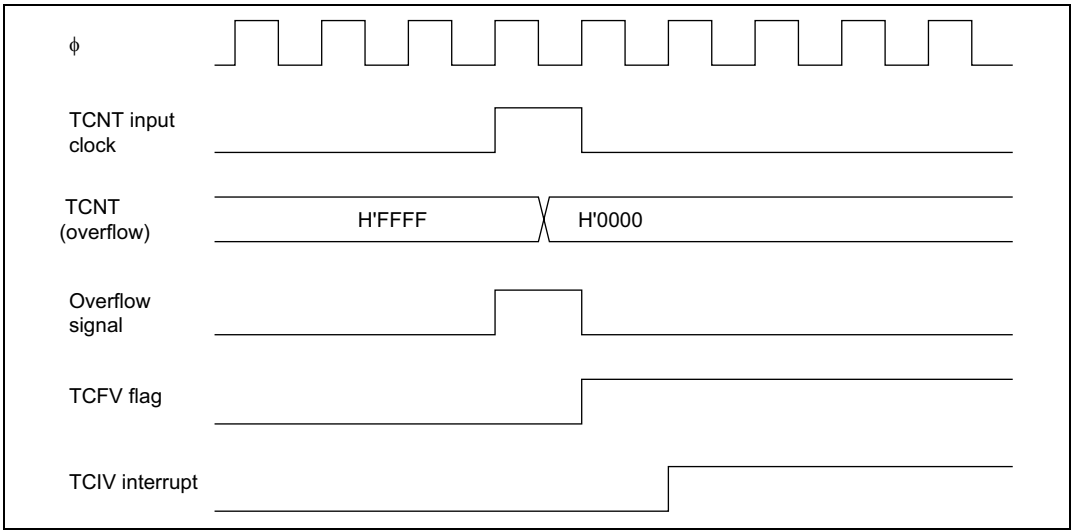

Figure 10-44 TCIV Interrupt Setting Timing

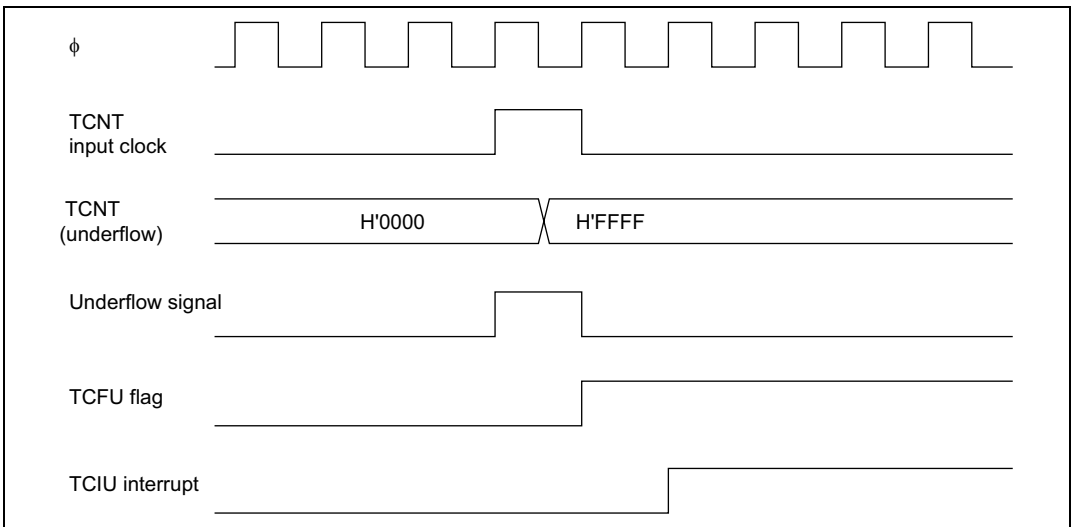

Figure 10-45 TCIU Interrupt Setting Timing

Status Flag Clearing Timing: After a status flag is read as 1 by the CPU, it is cleared by writing 0 to it. When the DTC* is activated, the flag is cleared automatically. Figure 10-46 shows the timing for status flag clearing by the CPU, and figure 10-47 shows the timing for status flag clearing by the DTC.

Note: * The DTC is not implemented in the H8S/2635 and H8S/2634.

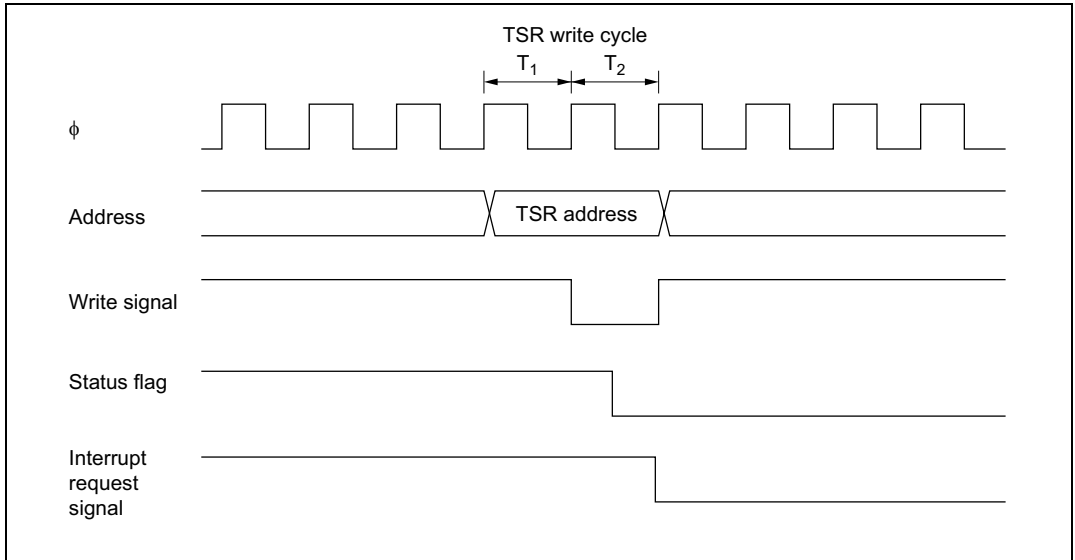

Figure 10-46 Timing for Status Flag Clearing by CPU

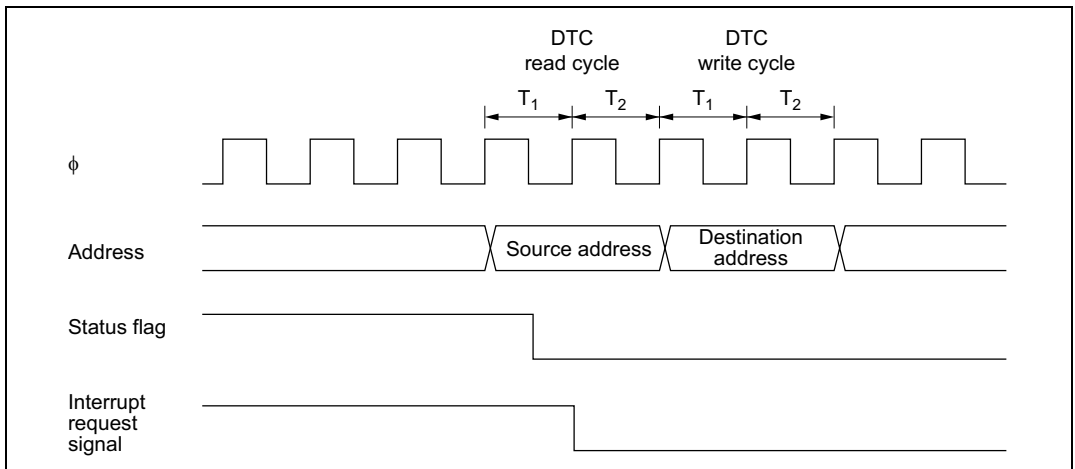

Figure 10-47 Timing for Status Flag Clearing by DTC Activation

10.7 Usage Notes

Note that the kinds of operation and contention described below occur during TPU operation.

Input Clock Restrictions: The input clock pulse width must be at least 1.5 states in the case of single-edge detection, and at least 2.5 states in the case of both-edge detection. The TPU will not operate properly with a narrower pulse width.

In phase counting mode, the phase difference and overlap between the two input clocks must be at least 1.5 states, and the pulse width must be at least 2.5 states. Figure 10-48 shows the input clock conditions in phase counting mode.

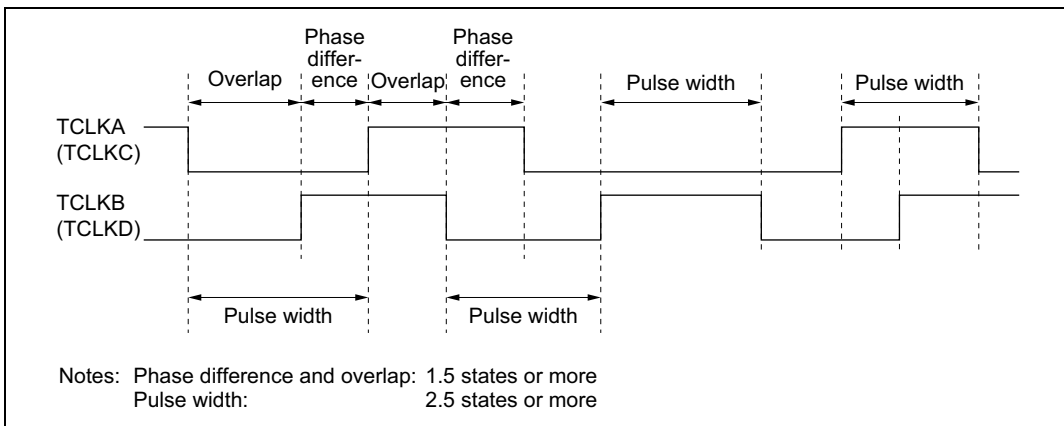

Figure 10-48 Phase Difference, Overlap, and Pulse Width in Phase Counting Mode

Caution on Period Setting: When counter clearing by compare match is set, TCNT is cleared in the final state in which it matches the TGR value (the point at which the count value matched by TCNT is updated). Consequently, the actual counter frequency is given by the following formula:

$$f = \frac{\phi}{(N + 1)}$$

Where f : Counter frequency
 ϕ : Operating frequency
 N : TGR set value

Contention between TCNT Write and Clear Operations: If the counter clear signal is generated in the T_2 state of a TCNT write cycle, TCNT clearing takes precedence and the TCNT write is not performed.

Figure 10-49 shows the timing in this case.

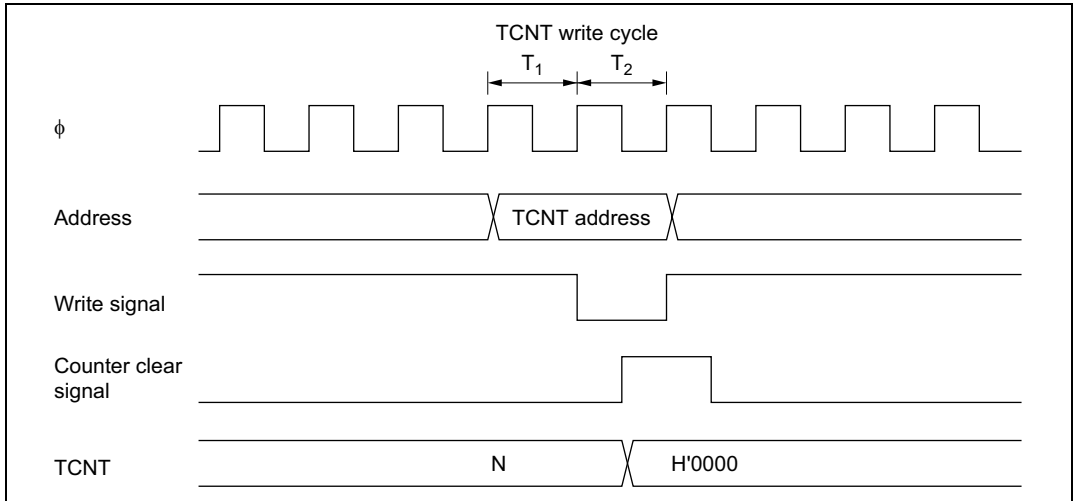

Figure 10-49 Contention between TCNT Write and Clear Operations

Contention between TCNT Write and Increment Operations: If incrementing occurs in the T_2 state of a TCNT write cycle, the TCNT write takes precedence and TCNT is not incremented.

Figure 10-50 shows the timing in this case.

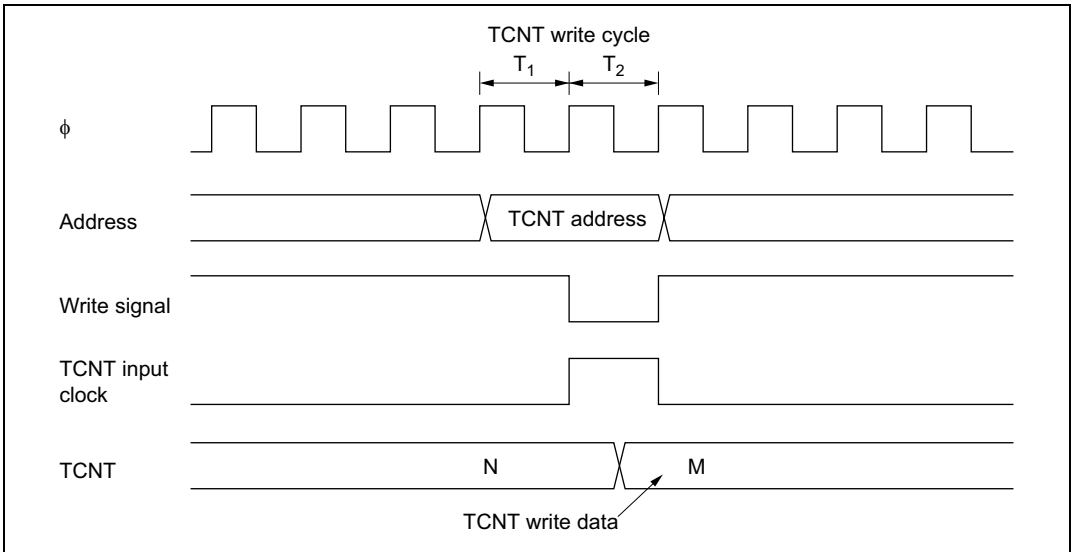

Figure 10-50 Contention between TCNT Write and Increment Operations

Contention between TGR Write and Compare Match: If a compare match occurs in the T_2 state of a TGR write cycle, the TGR write takes precedence and the compare match signal is inhibited. A compare match does not occur even if the same value as before is written.

Figure 10-51 shows the timing in this case.

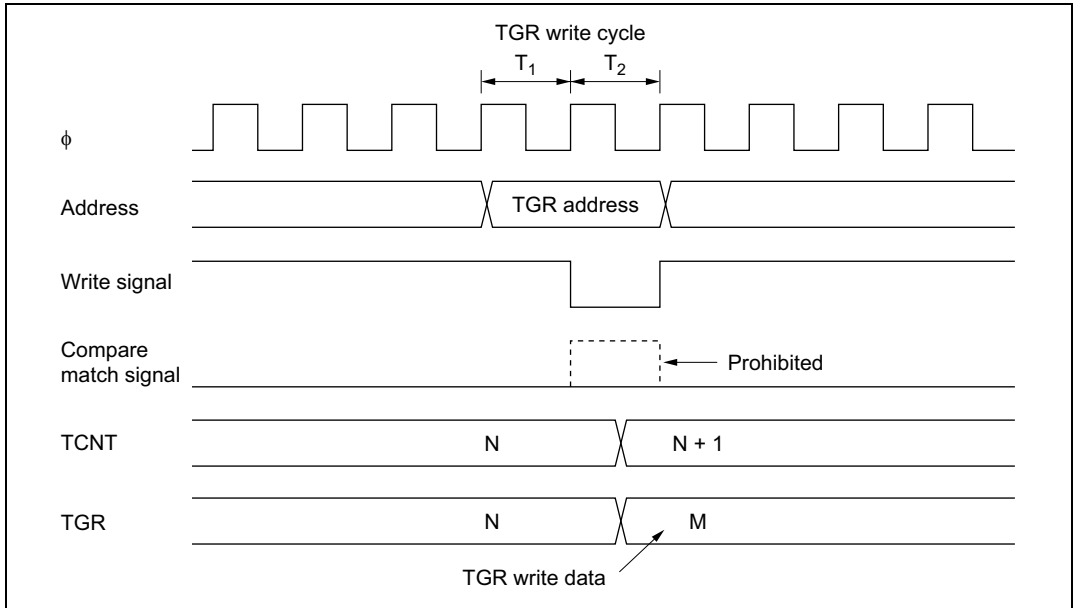

Figure 10-51 Contention between TGR Write and Compare Match

Contention between Buffer Register Write and Compare Match: If a compare match occurs in the T_2 state of a TGR write cycle, the data transferred to TGR by the buffer operation will be the data prior to the write.

Figure 10-52 shows the timing in this case.

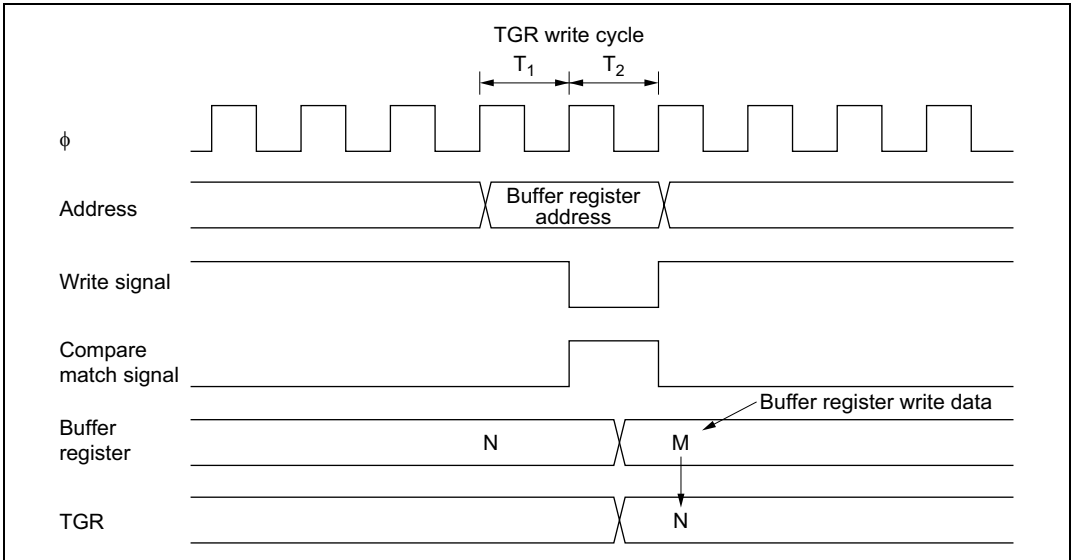

Figure 10-52 Contention between Buffer Register Write and Compare Match

Contention between TGR Read and Input Capture: If the input capture signal is generated in the T_1 state of a TGR read cycle, the data that is read will be the data after input capture transfer.

Figure 10-53 shows the timing in this case.

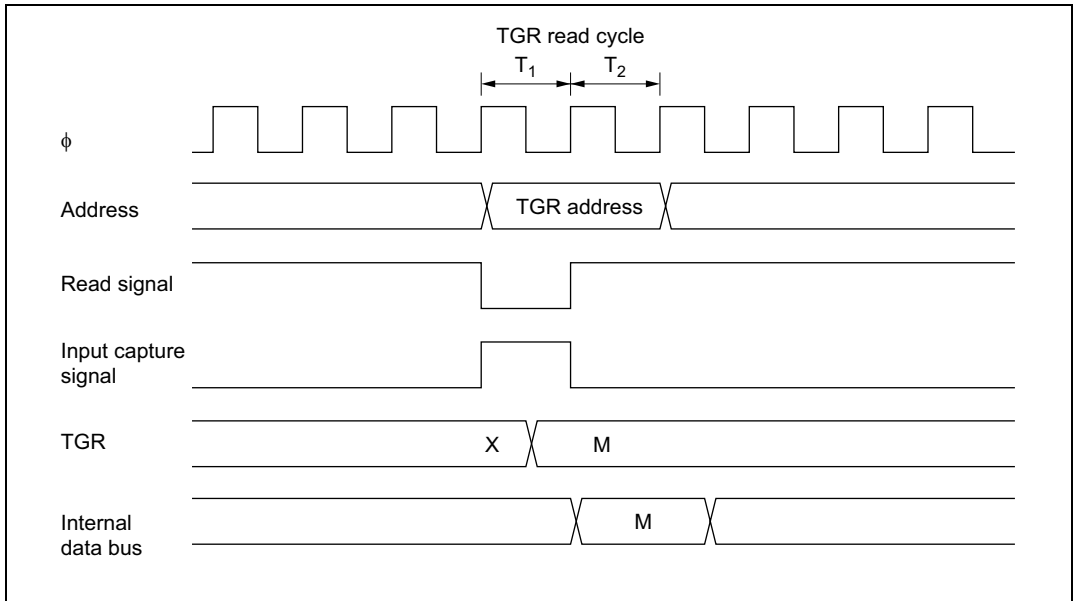

Figure 10-53 Contention between TGR Read and Input Capture

Contention between TGR Write and Input Capture: If the input capture signal is generated in the T_2 state of a TGR write cycle, the input capture operation takes precedence and the write to TGR is not performed.

Figure 10-54 shows the timing in this case.

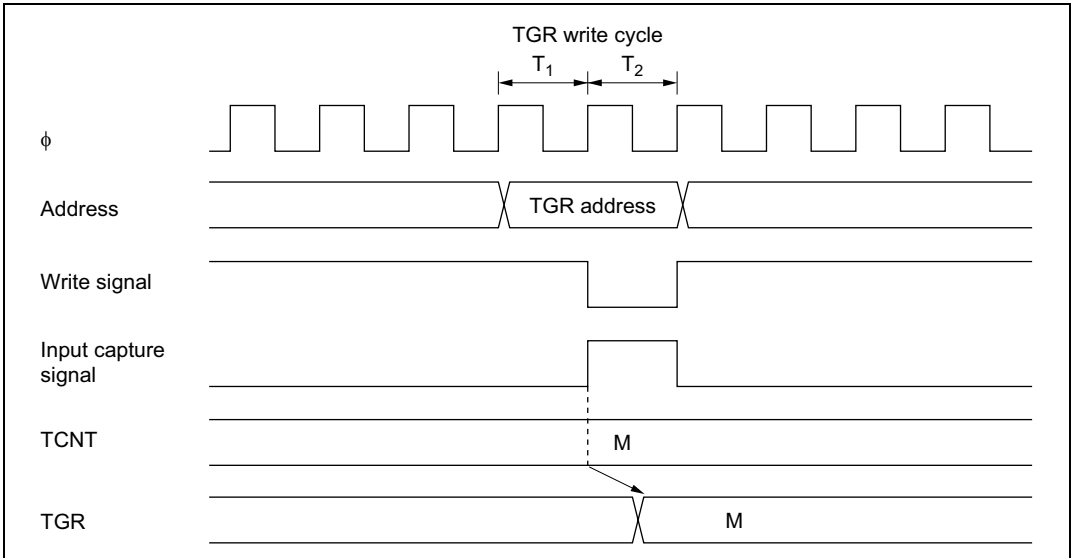

Figure 10-54 Contention between TGR Write and Input Capture

Contention between Buffer Register Write and Input Capture: If the input capture signal is generated in the T_2 state of a buffer write cycle, the buffer operation takes precedence and the write to the buffer register is not performed.

Figure 10-55 shows the timing in this case.

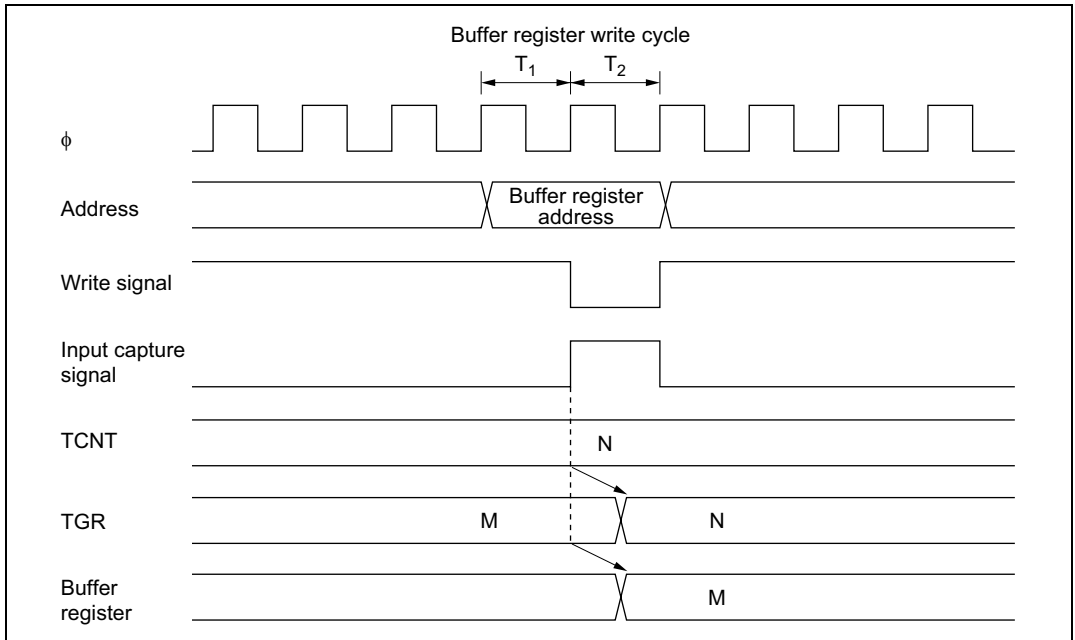

Figure 10-55 Contention between Buffer Register Write and Input Capture

Contention between Overflow/Underflow and Counter Clearing: If overflow/underflow and counter clearing occur simultaneously, the TCFV/TCFU flag in TSR is not set and TCNT clearing takes precedence.

Figure 10-56 shows the operation timing when a TGR compare match is specified as the clearing source, and H'FFFF is set in TGR.

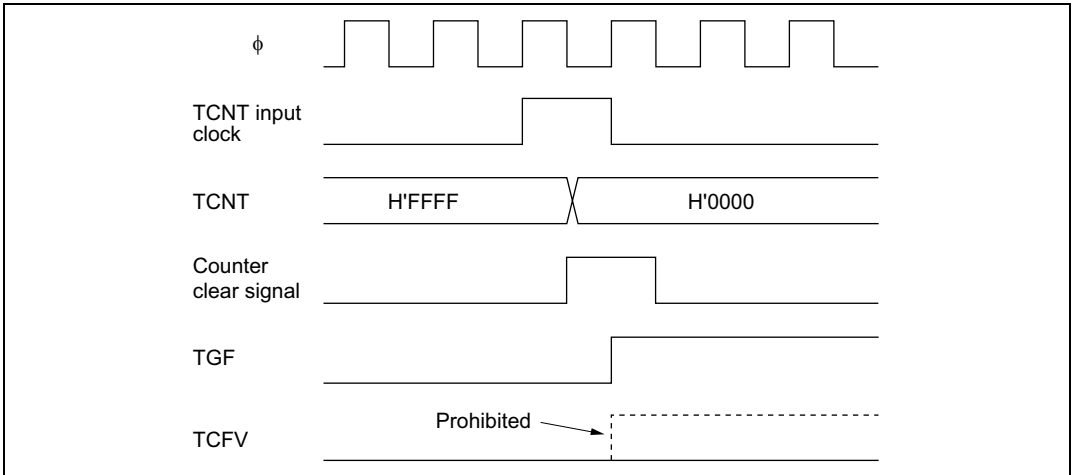

Figure 10-56 Contention between Overflow and Counter Clearing

Contention between TCNT Write and Overflow/Underflow: If there is an up-count or down-count in the T_2 state of a TCNT write cycle, and overflow/underflow occurs, the TCNT write takes precedence and the TCFV/TCFU flag in TSR is not set.

Figure 10-57 shows the operation timing when there is contention between TCNT write and overflow.

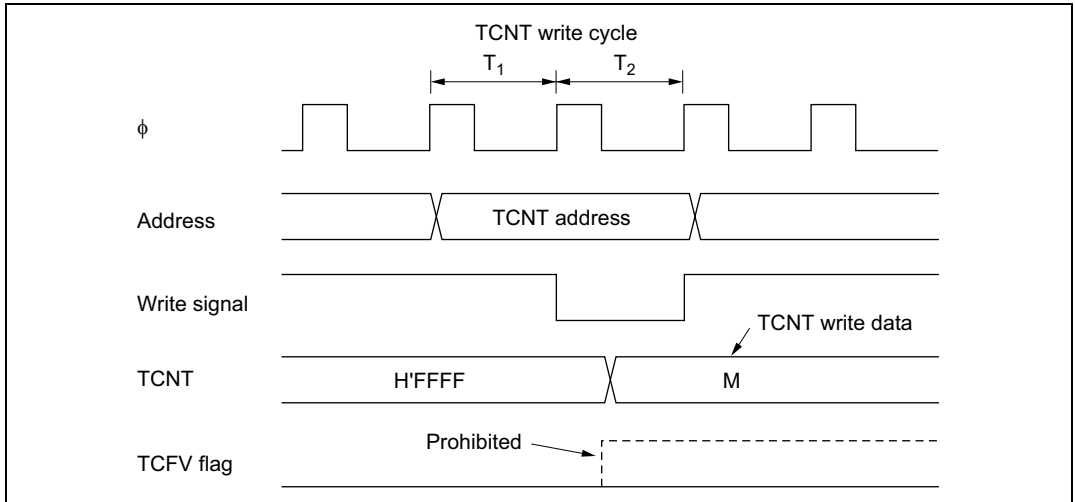

Figure 10-57 Contention between TCNT Write and Overflow

Multiplexing of I/O Pins: In the chip, the TCLKA input pin is multiplexed with the TIOCC0 I/O pin, the TCLKB input pin with the TIOCD0 I/O pin, the TCLKC input pin with the TIOCB1 I/O pin, and the TCLKD input pin with the TIOCB2 I/O pin. When an external clock is input, compare match output should not be performed from a multiplexed pin.

Interrupts and Module Stop Mode: If module stop mode is entered when an interrupt has been requested, it will not be possible to clear the CPU interrupt source or the DTC* activation source. Interrupts should therefore be disabled before entering module stop mode.

Note: * The DTC is not implemented in the H8S/2635 and H8S/2634.

Section 11 Programmable Pulse Generator (PPG)

Note: The H8S/2635 Group is not equipped with a PPG.

11.1 Overview

The chip has an on-chip programmable pulse generator (PPG) that provides pulse outputs by using the 16-bit timer-pulse unit (TPU) as a time base. The PPG pulse outputs are divided into 4-bit groups (group 3 and group 2) that can operate both simultaneously and independently.

11.1.1 Features

PPG features are listed below.

- 8-bit output data
 - Maximum 8-bit data can be output, and output can be enabled on a bit-by-bit basis
- Two output groups
 - Output trigger signals can be selected in 4-bit groups to provide up to two different 4-bit outputs
- Selectable output trigger signals
 - Output trigger signals can be selected for each group from the compare match signals of four TPU channels
- Non-overlap mode
 - A non-overlap margin can be provided between pulse outputs
- Can operate together with the data transfer controller (DTC)
 - The compare match signals selected as output trigger signals can activate the DTC for sequential output of data without CPU intervention
- Settable inverted output
 - Inverted data can be output for each group
- Module stop mode can be set
 - As the initial setting, PPG operation is halted. Register access is enabled by exiting module stop mode

11.1.2 Block Diagram

Figure 11-1 shows a block diagram of the PPG.

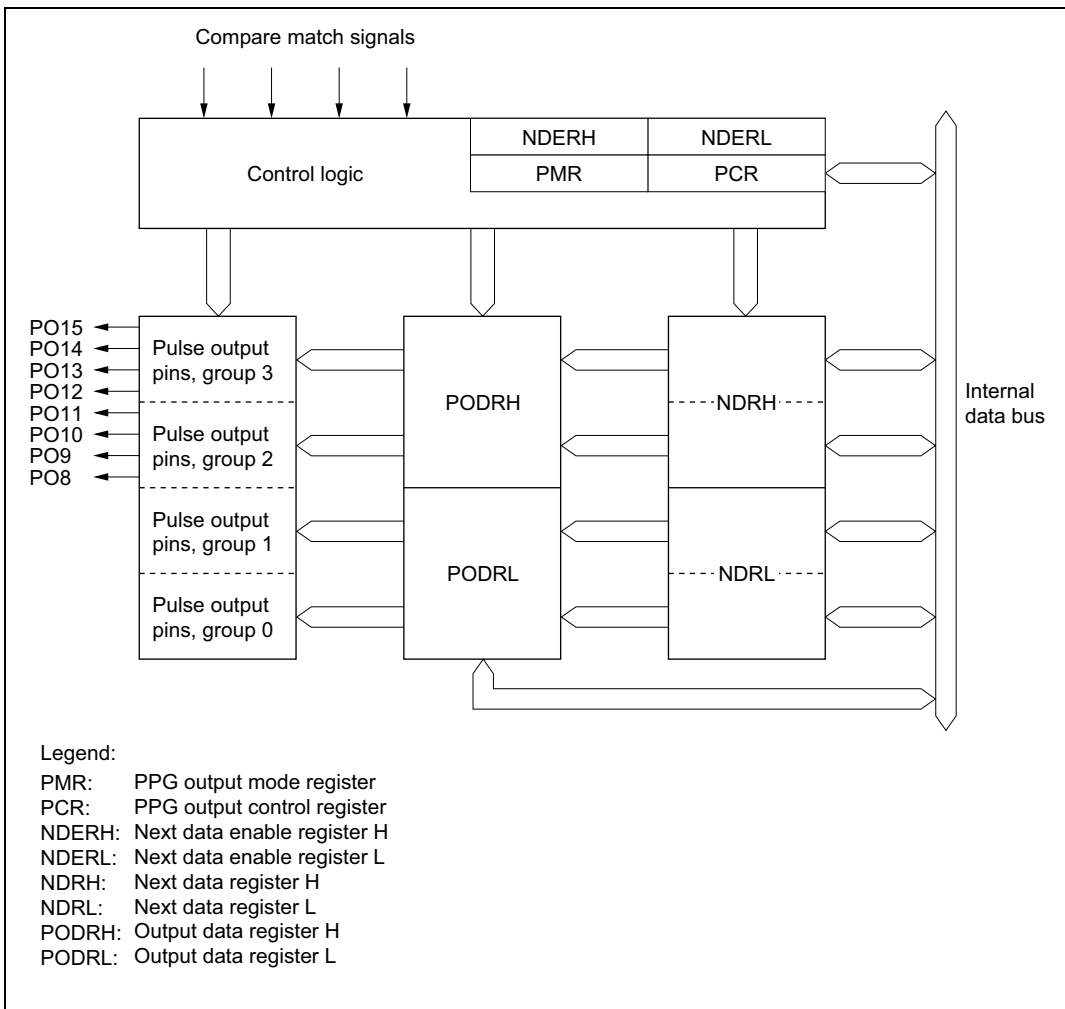

Figure 11-1 Block Diagram of PPG

11.1.3 Pin Configuration

Table 11-1 summarizes the PPG pins.

Table 11-1 PPG Pins

Name	Symbol	I/O	Function
Pulse output 8	PO8	Output	Group 2 pulse output
Pulse output 9	PO9	Output	
Pulse output 10	PO10	Output	
Pulse output 11	PO11	Output	
Pulse output 12	PO12	Output	Group 3 pulse output
Pulse output 13	PO13	Output	
Pulse output 14	PO14	Output	
Pulse output 15	PO15	Output	

11.1.4 Registers

Table 11-2 summarizes the PPG registers.

Table 11-2 PPG Registers

Name	Abbreviation	R/W	Initial Value	Address* ¹
PPG output control register	PCR	R/W	H'FF	H'FE26
PPG output mode register	PMR	R/W	H'F0	H'FE27
Next data enable register H	NDERH	R/W	H'00	H'FE28
Next data enable register L* ⁴	NDERL	R/W	H'00	H'FE29
Output data register H	PODRH	R/(W)* ²	H'00	H'FE2A
Output data register L* ⁴	PODRL	R/(W)* ²	H'00	H'FE2B
Next data register H	NDRH	R/W	H'00	H'FE2C* ³ H'FE2E
Next data register L* ⁴	NDRL	R/W	H'00	H'FE2D* ³ H'FE2F
Port 1 data direction register	P1DDR	W	H'00	H'FE30
Module stop control register A	MSTPCRA	R/W	H'3F	H'FDE8

Notes: 1. Lower 16 bits of the address.

2. Bits used for pulse output cannot be written to.

3. When the same output trigger is selected for pulse output groups 2 and 3 by the PCR setting, the NDRH address is H'FE2C. When the output triggers are different, the NDRH address is H'FE2E for group 2 and H'FE2C for group 3.

Similarly, when the same output trigger is selected for pulse output groups 0 and 1 by the PCR setting, the NDRL address is H'FE2D. When the output triggers are different, the NDRL address is H'FE2F for group 0 and H'FE2D for group 1.

4. The chip has no pins corresponding to pulse output groups 0 and 1.

11.2 Register Descriptions

11.2.1 Next Data Enable Registers H and L (NDERH, NDERL)

NDERH

Bit	:	7	6	5	4	3	2	1	0
		NDER15	NDER14	NDER13	NDER12	NDER11	NDER10	NDER9	NDER8
Initial value :		0	0	0	0	0	0	0	0
R/W	:	R/W	R/W	R/W	R/W	R/W	R/W	R/W	R/W

NDERL

Bit	:	7	6	5	4	3	2	1	0
		NDER7	NDER6	NDER5	NDER4	NDER3	NDER2	NDER1	NDER0
Initial value :		0	0	0	0	0	0	0	0
R/W	:	R/W	R/W	R/W	R/W	R/W	R/W	R/W	R/W

NDERH and NDERL are 8-bit readable/writable registers that enable or disable pulse output on a bit-by-bit basis.

If a bit is enabled for pulse output by NDERH or NDERL, the NDR value is automatically transferred to the corresponding PODR bit when the TPU compare match event specified by PCR occurs, updating the output value. If pulse output is disabled, the bit value is not transferred from NDR to PODR and the output value does not change.

NDERH and NDERL are each initialized to H'00 by a reset and in hardware standby mode. They are not initialized in software standby mode.

NDERH Bits 7 to 0—Next Data Enable 15 to 8 (NDER15 to NDER8): These bits enable or disable pulse output on a bit-by-bit basis.

Bits 7 to 0

NDER15 to NDER8	Description
0	Pulse outputs PO15 to PO8 are disabled (NDR15 to NDR8 are not transferred to POD15 to POD8) (Initial value)
1	Pulse outputs PO15 to PO8 are enabled (NDR15 to NDR8 are transferred to POD15 to POD8)

NDERL Bits 7 to 0—Next Data Enable 7 to 0 (NDER7 to NDER0): These bits enable or disable pulse output on a bit-by-bit basis.

Bits 7 to 0

NDER7 to NDER0	Description
0	Pulse outputs PO7 to PO0 are disabled (NDR7 to NDR0 are not transferred to POD7 to POD0) (Initial value)
1	Pulse outputs PO7 to PO0 are enabled (NDR7 to NDR0 are transferred to POD7 to POD0)

11.2.2 Output Data Registers H and L (PODRH, PODRL)**PODRH**

Bit	:	7	6	5	4	3	2	1	0
		POD15	POD14	POD13	POD12	POD11	POD10	POD9	POD8
Initial value :		0	0	0	0	0	0	0	0
R/W	:	R/(W)*	R/(W)*	R/(W)*	R/(W)*	R/(W)*	R/(W)*	R/(W)*	R/(W)*

PODRL

Bit	:	7	6	5	4	3	2	1	0
		POD7	POD6	POD5	POD4	POD3	POD2	POD1	POD0
Initial value :		0	0	0	0	0	0	0	0
R/W	:	R/(W)*	R/(W)*	R/(W)*	R/(W)*	R/(W)*	R/(W)*	R/(W)*	R/(W)*

Note: * A bit that has been set for pulse output by NDER is read-only.

PODRH and PODRL are 8-bit readable/writable registers that store output data for use in pulse output. However, the chip has no pins corresponding to PODRL.

11.2.3 Next Data Registers H and L (NDRH, NDRL)

NDRH and NDRL are 8-bit readable/writable registers that store the next data for pulse output. During pulse output, the contents of NDRH and NDRL are transferred to the corresponding bits in PODRH and PODRL when the TPU compare match event specified by PCR occurs. The NDRH and NDRL addresses differ depending on whether pulse output groups have the same output trigger or different output triggers. For details see section 11.2.4, Notes on NDR Access.

NDRH and NDRL are each initialized to H'00 by a reset and in hardware standby mode. They are not initialized in software standby mode.

11.2.4 Notes on NDR Access

The NDRH and NDRL addresses differ depending on whether pulse output groups have the same output trigger or different output triggers.

Same Trigger for Pulse Output Groups: If pulse output groups 2 and 3 are triggered by the same compare match event, the NDRH address is H'FE2C. The upper 4 bits belong to group 3 and the lower 4 bits to group 2. Address H'FE2E consists entirely of reserved bits that cannot be modified and are always read as 1.

Address H'FE2C

Bit	:	7	6	5	4	3	2	1	0
		NDR15	NDR14	NDR13	NDR12	NDR11	NDR10	NDR9	NDR8
Initial value	:	0	0	0	0	0	0	0	0
R/W	:	R/W	R/W	R/W	R/W	R/W	R/W	R/W	R/W

Address H'FE2E

Bit	:	7	6	5	4	3	2	1	0
		—	—	—	—	—	—	—	—
Initial value	:	1	1	1	1	1	1	1	1
R/W	:	—	—	—	—	—	—	—	—

If pulse output groups 0 and 1 are triggered by the same compare match event, the NDRL address is H'FE2D. The upper 4 bits belong to group 1 and the lower 4 bits to group 0. Address H'FE2F consists entirely of reserved bits that cannot be modified and are always read as 1. However, the chip has no output pins corresponding to pulse output groups 0 and 1.

Address H'FE2D

Bit	:	7	6	5	4	3	2	1	0
		NDR7	NDR6	NDR5	NDR4	NDR3	NDR2	NDR1	NDR0
Initial value :		0	0	0	0	0	0	0	0
R/W	:	R/W	R/W	R/W	R/W	R/W	R/W	R/W	R/W

Address H'FE2F

Bit	:	7	6	5	4	3	2	1	0
		—	—	—	—	—	—	—	—
Initial value :		1	1	1	1	1	1	1	1
R/W	:	—	—	—	—	—	—	—	—

Different Triggers for Pulse Output Groups: If pulse output groups 2 and 3 are triggered by different compare match events, the address of the upper 4 bits in NDRH (group 3) is H'FE2C and the address of the lower 4 bits (group 2) is H'FE2E. Bits 3 to 0 of address H'FE2C and bits 7 to 4 of address H'FE2E are reserved bits that cannot be modified and are always read as 1.

Address H'FE2C

Bit	:	7	6	5	4	3	2	1	0
		NDR15	NDR14	NDR13	NDR12	—	—	—	—
Initial value :		0	0	0	0	1	1	1	1
R/W	:	R/W	R/W	R/W	R/W	—	—	—	—

Address H'FE2E

Bit	:	7	6	5	4	3	2	1	0
		—	—	—	—	NDR11	NDR10	NDR9	NDR8
Initial value :		1	1	1	1	0	0	0	0
R/W	:	—	—	—	—	R/W	R/W	R/W	R/W

If pulse output groups 0 and 1 are triggered by different compare match event, the address of the upper 4 bits in NDRL (group 1) is H'FE2D and the address of the lower 4 bits (group 0) is H'FE2F. Bits 3 to 0 of address H'FE2D and bits 7 to 4 of address H'FE2F are reserved bits that cannot be modified and are always read as 1. However, the chip has no output pins corresponding to pulse output groups 0 and 1.

Address H'FE2D

Bit	:	7	6	5	4	3	2	1	0
		NDR7	NDR6	NDR5	NDR4	—	—	—	—
Initial value :		0	0	0	0	1	1	1	1
R/W	:	R/W	R/W	R/W	R/W	—	—	—	—

Address H'FE2F

Bit	:	7	6	5	4	3	2	1	0
		—	—	—	—	NDR3	NDR2	NDR1	NDR0
Initial value :		1	1	1	1	0	0	0	0
R/W	:	—	—	—	—	R/W	R/W	R/W	R/W

11.2.5 PPG Output Control Register (PCR)

Bit	:	7	6	5	4	3	2	1	0
		G3CMS1	G3CMS0	G2CMS1	G2CMS0	G1CMS1	G1CMS0	G0CMS1	G0CMS0
Initial value :		1	1	1	1	1	1	1	1
R/W	:	R/W	R/W	R/W	R/W	R/W	R/W	R/W	R/W

PCR is an 8-bit readable/writable register that selects output trigger signals for PPG outputs on a group-by-group basis.

PCR is initialized to H'FF by a reset and in hardware standby mode. It is not initialized in software standby mode.

Bits 7 and 6—Group 3 Compare Match Select 1 and 0 (G3CMS1, G3CMS0): These bits select the compare match that triggers pulse output group 3 (pins PO15 to PO12).

		Description
Bit 7 G3CMS1	Bit 6 G3CMS0	Output Trigger for Pulse Output Group 3
0	0	Compare match in TPU channel 0
	1	Compare match in TPU channel 1
1	0	Compare match in TPU channel 2
	1	Compare match in TPU channel 3 (Initial value)

Bits 5 and 4—Group 2 Compare Match Select 1 and 0 (G2CMS1, G2CMS0): These bits select the compare match that triggers pulse output group 2 (pins PO11 to PO8).

		Description
Bit 5 G2CMS1	Bit 4 G2CMS0	Output Trigger for Pulse Output Group 2
0	0	Compare match in TPU channel 0
	1	Compare match in TPU channel 1
1	0	Compare match in TPU channel 2
	1	Compare match in TPU channel 3 (Initial value)

Bits 3 and 2—Group 1 Compare Match Select 1 and 0 (G1CMS1, G1CMS0): These bits select the compare match that triggers pulse output group 1 (pins PO7 to PO4). However, the chip has no output pins corresponding to pulse output group 1.

		Description
Bit 3 G1CMS1	Bit 2 G1CMS0	Output Trigger for Pulse Output Group 1
0	0	Compare match in TPU channel 0
	1	Compare match in TPU channel 1
1	0	Compare match in TPU channel 2
	1	Compare match in TPU channel 3 (Initial value)

Bits 1 and 0—Group 0 Compare Match Select 1 and 0 (G0CMS1, G0CMS0): These bits select the compare match that triggers pulse output group 0 (pins PO3 to PO0). However, the chip has no output pins corresponding to pulse output group 0.

		Description
Bit 1 G0CMS1	Bit 0 G0CMS0	Output Trigger for Pulse Output Group 0
0	0	Compare match in TPU channel 0
	1	Compare match in TPU channel 1
1	0	Compare match in TPU channel 2
	1	Compare match in TPU channel 3 (Initial value)

11.2.6 PPG Output Mode Register (PMR)

Bit	:	7	6	5	4	3	2	1	0
		G3INV	G2INV	G1INV	G0INV	G3NOV	G2NOV	G1NOV	G0NOV
Initial value :		1	1	1	1	0	0	0	0
R/W	:	R/W	R/W	R/W	R/W	R/W	R/W	R/W	R/W

PMR is an 8-bit readable/writable register that selects pulse output inversion and non-overlapping operation for each group.

The output trigger period of a non-overlapping operation PPG output waveform is set in TGRB and the non-overlap margin is set in TGRA. The output values change at compare match A and B.

For details, see section 11.3.4, Non-Overlapping Pulse Output.

PMR is initialized to H'F0 by a reset and in hardware standby mode. It is not initialized in software standby mode.

Bit 7—Group 3 Inversion (G3INV): Selects direct output or inverted output for pulse output group 3 (pins PO15 to PO12).

Bit 7

G3INV	Description
0	Inverted output for pulse output group 3 (low-level output at pin for a 1 in PODRH)
1	Direct output for pulse output group 3 (high-level output at pin for a 1 in PODRH) (Initial value)

Bit 6—Group 2 Inversion (G2INV): Selects direct output or inverted output for pulse output group 2 (pins PO11 to PO8).

Bit 6

G2INV	Description
0	Inverted output for pulse output group 2 (low-level output at pin for a 1 in PODRH)
1	Direct output for pulse output group 2 (high-level output at pin for a 1 in PODRH) (Initial value)

Bit 5—Group 1 Inversion (G1INV): Selects direct output or inverted output for pulse output group 1 (pins PO7 to PO4). However, the chip has no pins corresponding to pulse output group 1.

Bit 5

G1INV	Description
0	Inverted output for pulse output group 1 (low-level output at pin for a 1 in PODRL)
1	Direct output for pulse output group 1 (high-level output at pin for a 1 in PODRL) (Initial value)

Bit 4—Group 0 Inversion (G0INV): Selects direct output or inverted output for pulse output group 0 (pins PO3 to PO0). However, the chip has no pins corresponding to pulse output group 0.

Bit 4

G0INV	Description
0	Inverted output for pulse output group 0 (low-level output at pin for a 1 in PODRL)
1	Direct output for pulse output group 0 (high-level output at pin for a 1 in PODRL) (Initial value)

Bit 3—Group 3 Non-Overlap (G3NOV): Selects normal or non-overlapping operation for pulse output group 3 (pins PO15 to PO12).

Bit 3

G3NOV	Description
0	Normal operation in pulse output group 3 (output values updated at compare match A in the selected TPU channel) (Initial value)
1	Non-overlapping operation in pulse output group 3 (independent 1 and 0 output at compare match A or B in the selected TPU channel)

Bit 2—Group 2 Non-Overlap (G2NOV): Selects normal or non-overlapping operation for pulse output group 2 (pins PO11 to PO8).

Bit 2

G2NOV	Description
0	Normal operation in pulse output group 2 (output values updated at compare match A in the selected TPU channel) (Initial value)
1	Non-overlapping operation in pulse output group 2 (independent 1 and 0 output at compare match A or B in the selected TPU channel)

Bit 1—Group 1 Non-Overlap (G1NOV): Selects normal or non-overlapping operation for pulse output group 1 (pins PO7 to PO4). However, the chip has no pins corresponding to pulse output group 1.

Bit 1

G1NOV	Description
0	Normal operation in pulse output group 1 (output values updated at compare match A in the selected TPU channel) (Initial value)
1	Non-overlapping operation in pulse output group 1 (independent 1 and 0 output at compare match A or B in the selected TPU channel)

Bit 0—Group 0 Non-Overlap (G0NOV): Selects normal or non-overlapping operation for pulse output group 0 (pins PO3 to PO0). However, the chip has no pins corresponding to pulse output group 0.

Bit 0

G0NOV	Description
0	Normal operation in pulse output group 0 (output values updated at compare match A in the selected TPU channel) (Initial value)
1	Non-overlapping operation in pulse output group 0 (independent 1 and 0 output at compare match A or B in the selected TPU channel)

11.2.7 Port 1 Data Direction Register (P1DDR)

Bit	:	7	6	5	4	3	2	1	0
		P17DDR	P16DDR	P15DDR	P14DDR	P13DDR	P12DDR	P11DDR	P10DDR
Initial value :		0	0	0	0	0	0	0	0
R/W	:	W	W	W	W	W	W	W	W

P1DDR is an 8-bit write-only register, the individual bits of which specify input or output for the pins of port 1.

Port 1 is multiplexed with pins PO15 to PO8. Bits corresponding to pins used for PPG output must be set to 1. For further information about P1DDR, see section 9.2, Port 1.

11.2.8 Module Stop Control Register A (MSTPCRA)

Bit	:	7	6	5	4	3	2	1	0
		MSTPA7	MSTPA6	MSTPA5	MSTPA4	MSTPA3	MSTPA2	MSTPA1	MSTPA0
Initial value :		0	0	1	1	1	1	1	1
R/W	:	R/W	R/W	R/W	R/W	R/W	R/W	R/W	R/W

MSTPCRA is a 16-bit readable/writable register that performs module stop mode control.

When the MSTPA3 bit in MSTPCRA is set to 1, PPG operation stops at the end of the bus cycle and a transition is made to module stop mode. Registers cannot be read or written to in module stop mode. For details, see section 23A.5, 23B.5, Module Stop Mode.

MSTPCRA is initialized to H'3F by a reset and in hardware standby mode. It is not initialized by a manual reset and in software standby mode.

Bit 3—Module Stop (MSTPA3): Specifies the PPG module stop mode.

Bit 3**MSTPA3 Description**

0	PPG module stop mode cleared	
1	PPG module stop mode set	(Initial value)

11.3 Operation

11.3.1 Overview

PPG pulse output is enabled when the corresponding bits in P1DDR and NDER are set to 1. In this state the corresponding PODR contents are output.

When the compare match event specified by PCR occurs, the corresponding NDR bit contents are transferred to PODR to update the output values.

Figure 11-2 illustrates the PPG output operation and table 11-3 summarizes the PPG operating conditions.

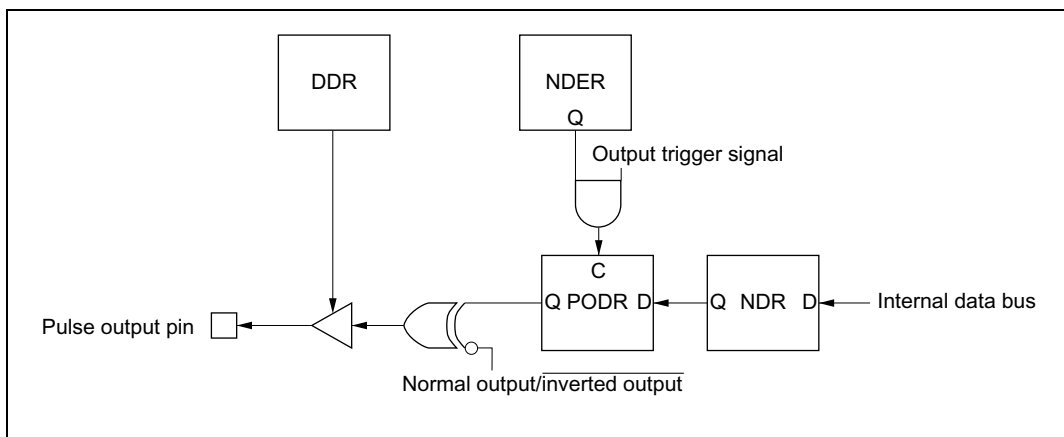

Figure 11-2 PPG Output Operation

Table 11-3 PPG Operating Conditions

NDR	DDR	Pin Function
0	0	Generic input port
	1	Generic output port
1	0	Generic input port (but the PODR bit is a read-only bit, and when compare match occurs, the NDR bit value is transferred to the PODR bit)
	1	PPG pulse output

Sequential output of data of up to 16 bits is possible by writing new output data to NDR before the next compare match. For details of non-overlapping operation, see section 11.3.4, Non-Overlapping Pulse Output.

11.3.2 Output Timing

If pulse output is enabled, NDR contents are transferred to PODR and output when the specified compare match event occurs. Figure 11-3 shows the timing of these operations for the case of normal output in groups 2 and 3, triggered by compare match A.

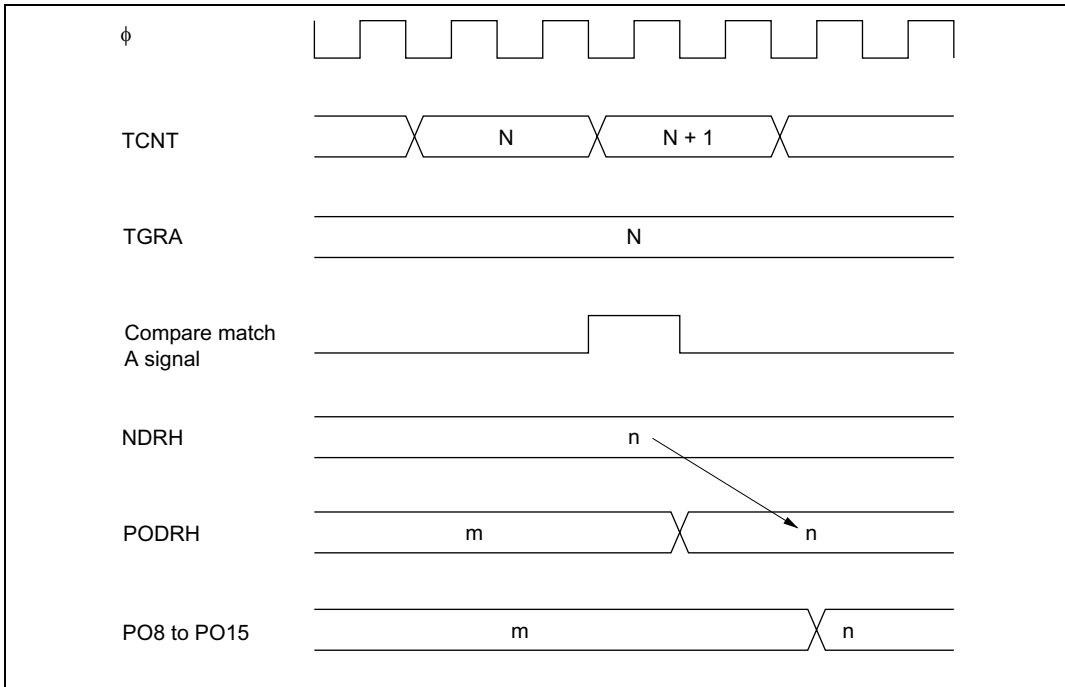

Figure 11-3 Timing of Transfer and Output of NDR Contents (Example)

11.3.3 Normal Pulse Output

Sample Setup Procedure for Normal Pulse Output: Figure 11-4 shows a sample procedure for setting up normal pulse output.

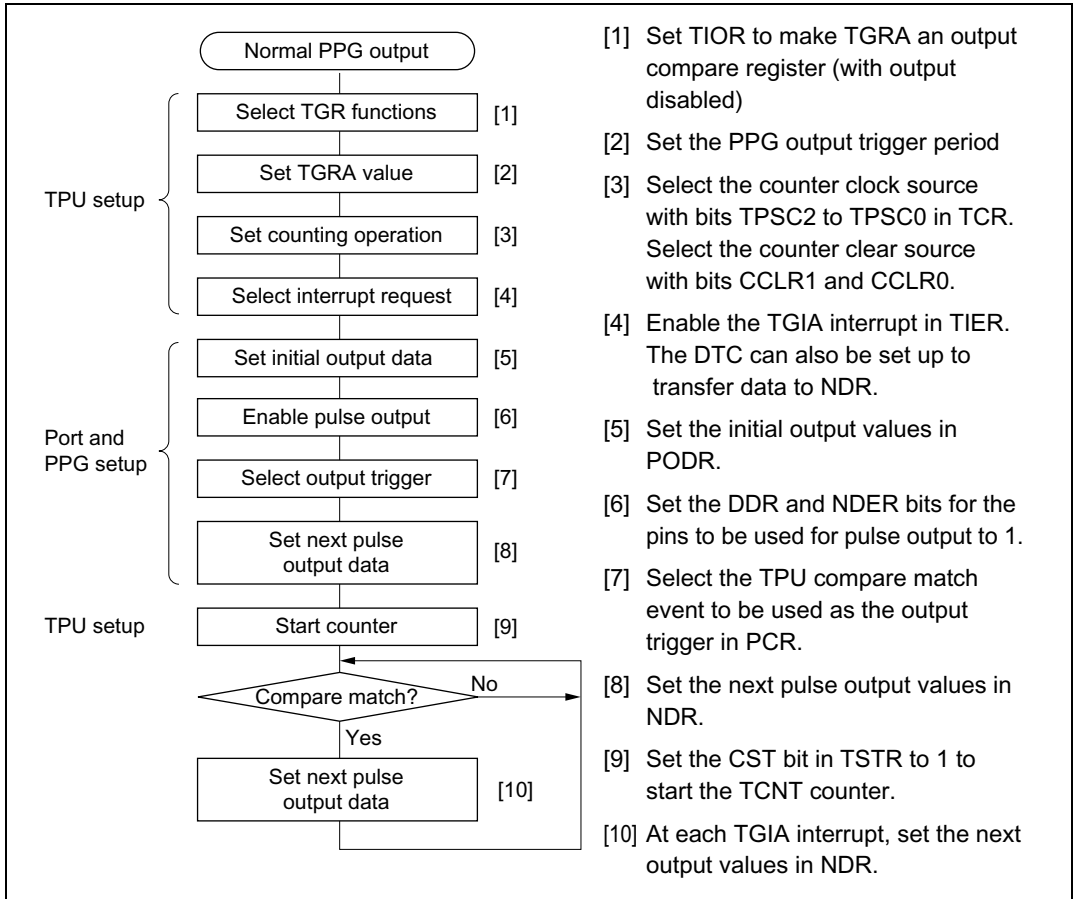

Figure 11-4 Setup Procedure for Normal Pulse Output (Example)

Example of Normal Pulse Output (Example of Five-Phase Pulse Output): Figure 11-5 shows an example in which pulse output is used for cyclic five-phase pulse output.

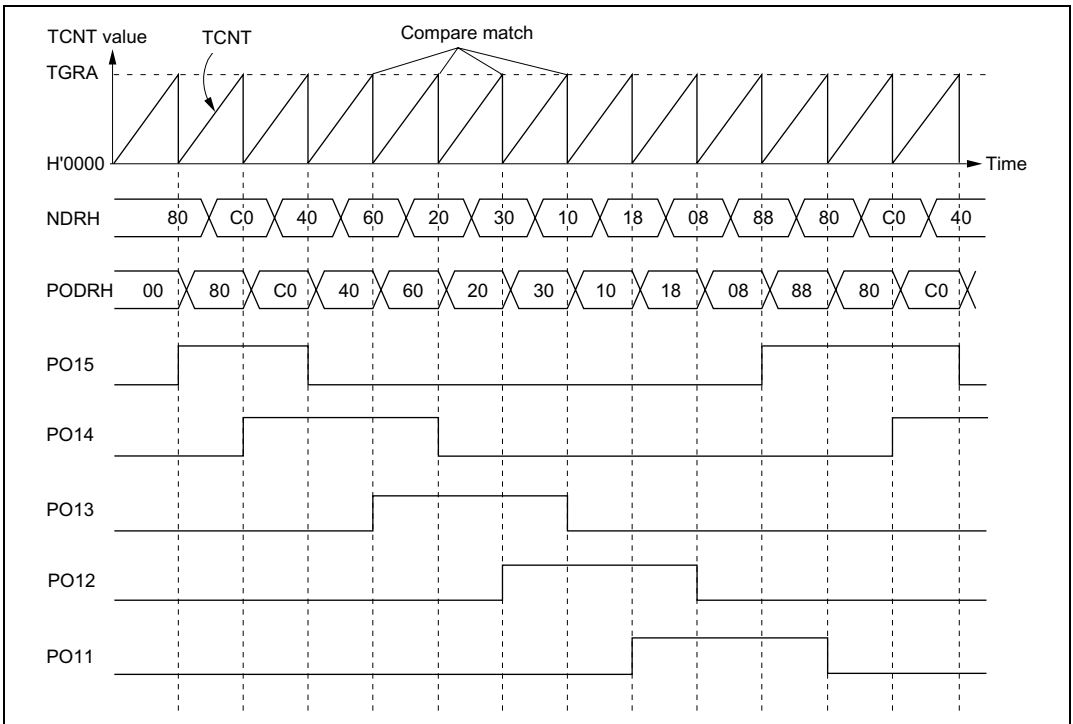

Figure 11-5 Normal Pulse Output Example (Five-Phase Pulse Output)

- [1] Set up the TPU channel to be used as the output trigger channel so that TGRA is an output compare register and the counter will be cleared by compare match A. Set the trigger period in TGRA and set the TGIEA bit in TIER to 1 to enable the compare match A (TGIA) interrupt.
- [2] Write H'F8 in P1DDR and NDRH, and set the G3CMS1, G3CMS0, G2CMS1, and G2CMS0 bits in PCR to select compare match in the TPU channel set up in the previous step to be the output trigger. Write output data H'80 in NDRH.
- [3] The timer counter in the TPU channel starts. When compare match A occurs, the NDRH contents are transferred to PODRH and output. The TGIA interrupt handling routine writes the next output data (H'C0) in NDRH.
- [4] Five-phase overlapping pulse output (one or two phases active at a time) can be obtained subsequently by writing H'40, H'60, H'20, H'30, H'10, H'18, H'08, H'88... at successive TGIA

interrupts. If the DTC is set for activation by this interrupt, pulse output can be obtained without imposing a load on the CPU.

11.3.4 Non-Overlapping Pulse Output

Sample Setup Procedure for Non-Overlapping Pulse Output: Figure 11-6 shows a sample procedure for setting up non-overlapping pulse output.

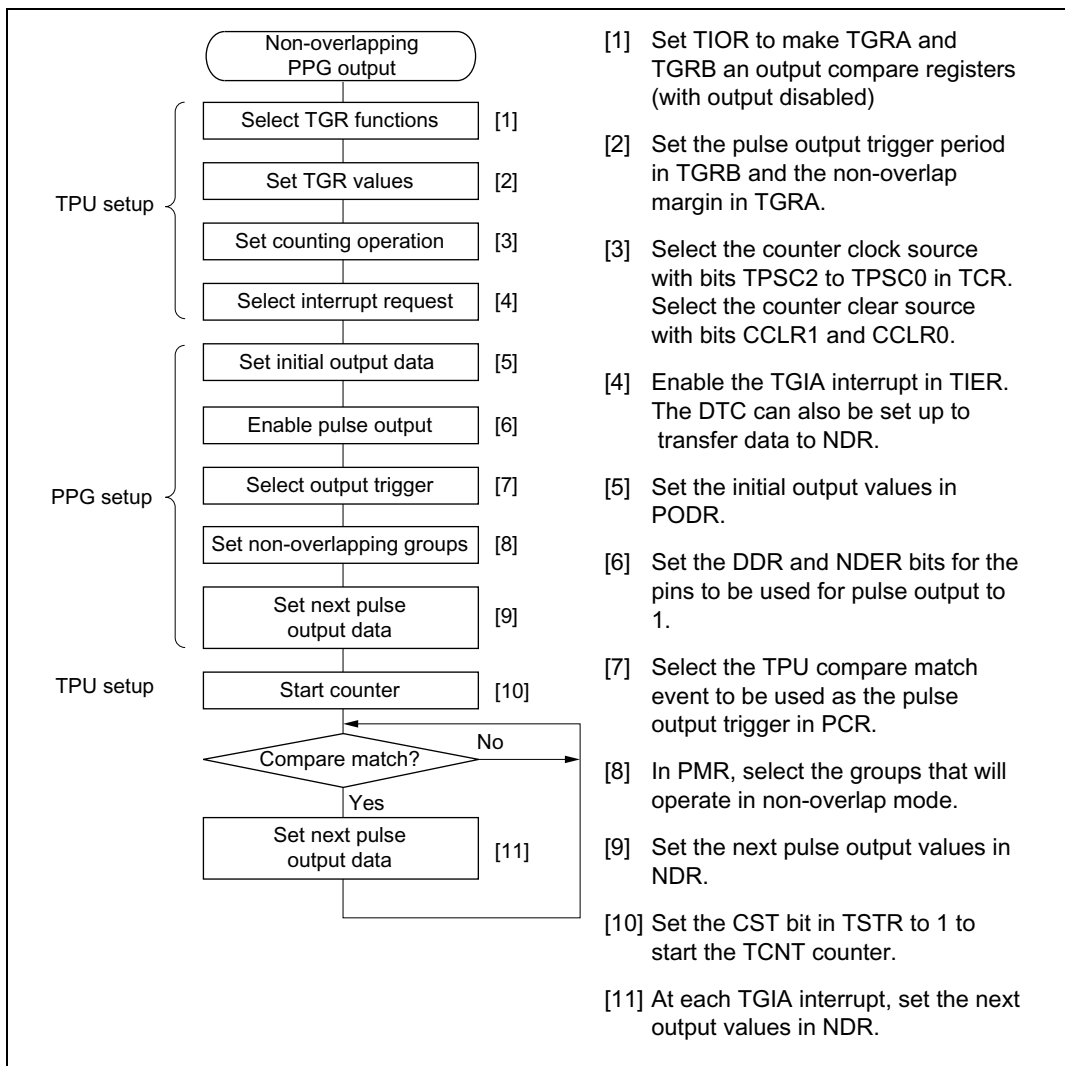

Figure 11-6 Setup Procedure for Non-Overlapping Pulse Output (Example)

Example of Non-Overlapping Pulse Output (Example of Four-Phase Complementary Non-Overlapping Output): Figure 11-7 shows an example in which pulse output is used for four-phase complementary non-overlapping pulse output.

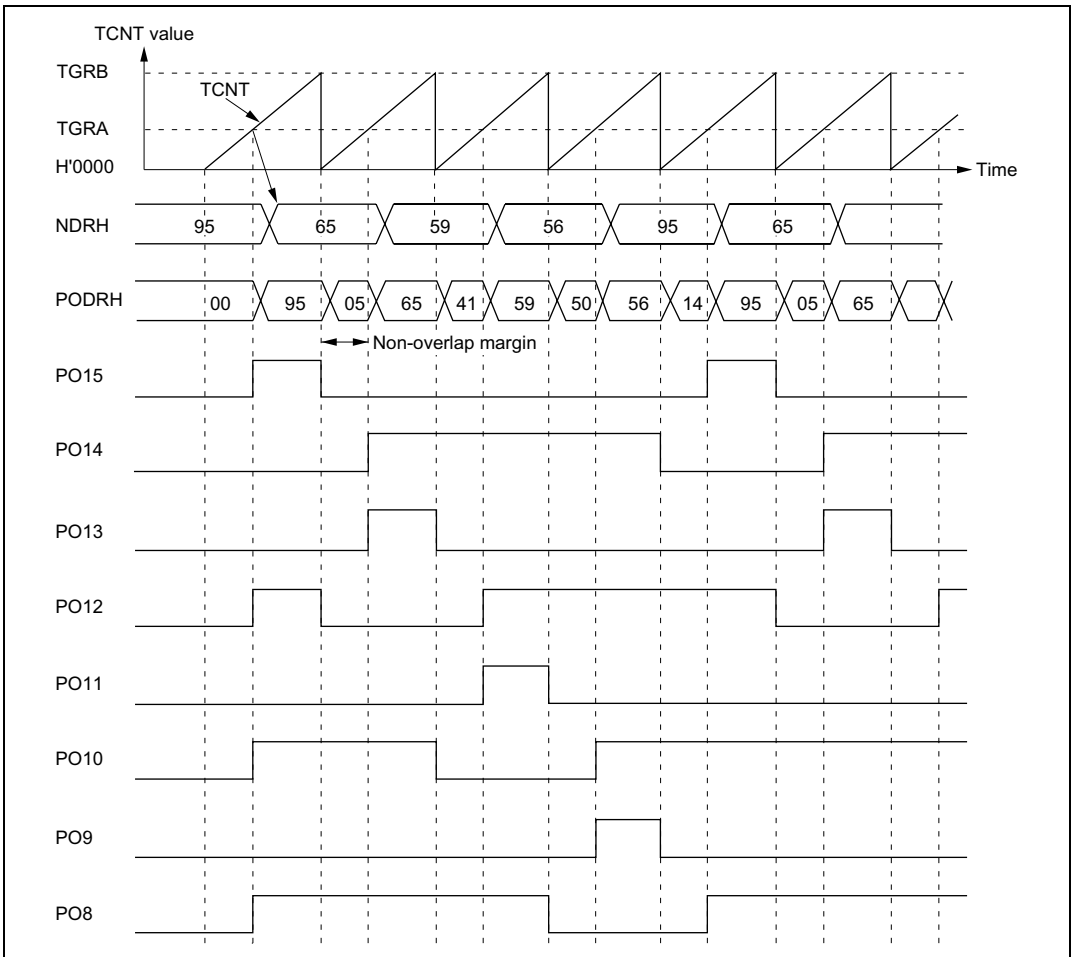

Figure 11-7 Non-Overlapping Pulse Output Example (Four-Phase Complementary)

- [1] Set up the TPU channel to be used as the output trigger channel so that TGRA and TGRB are output compare registers. Set the trigger period in TGRB and the non-overlap margin in TGRA, and set the counter to be cleared by compare match B. Set the TGIEA bit in TIER to 1 to enable the TGIA interrupt.
- [2] Write H'FF in P1DDR and NDERH, and set the G3CMS1, G3CMS0, G2CMS1, and G2CMS0 bits in PCR to select compare match in the TPU channel set up in the previous step to be the output trigger. Set the G3NOV and G2NOV bits in PMR to 1 to select non-overlapping output. Write output data H'95 in NDRH.
- [3] The timer counter in the TPU channel starts. When a compare match with TGRB occurs, outputs change from 1 to 0. When a compare match with TGRA occurs, outputs change from 0 to 1 (the change from 0 to 1 is delayed by the value set in TGRA). The TGIA interrupt handling routine writes the next output data (H'65) in NDRH.
- [4] Four-phase complementary non-overlapping pulse output can be obtained subsequently by writing H'59, H'56, H'95... at successive TGIA interrupts. If the DTC is set for activation by this interrupt, pulse output can be obtained without imposing a load on the CPU.

11.3.5 Inverted Pulse Output

If the G3INV, G2INV, G1INV, and G0INV bits in PMR are cleared to 0, values that are the inverse of the PODR contents can be output.

Figure 11-8 shows the outputs when G3INV and G2INV are cleared to 0, in addition to the settings of figure 11-7.

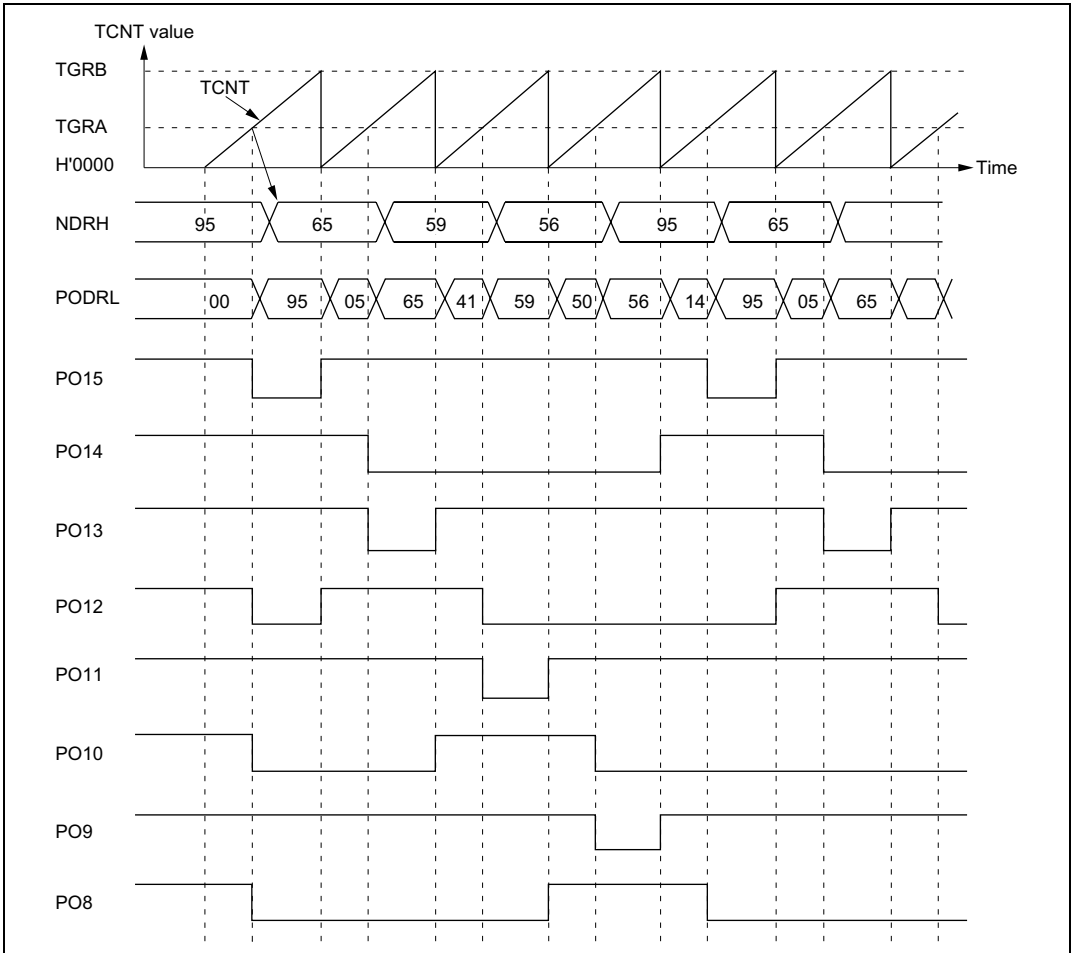

Figure 11-8 Inverted Pulse Output (Example)

11.3.6 Pulse Output Triggered by Input Capture

Pulse output can be triggered by TPU input capture as well as by compare match. If TGRA functions as an input capture register in the TPU channel selected by PCR, pulse output will be triggered by the input capture signal.

Figure 11-9 shows the timing of this output.

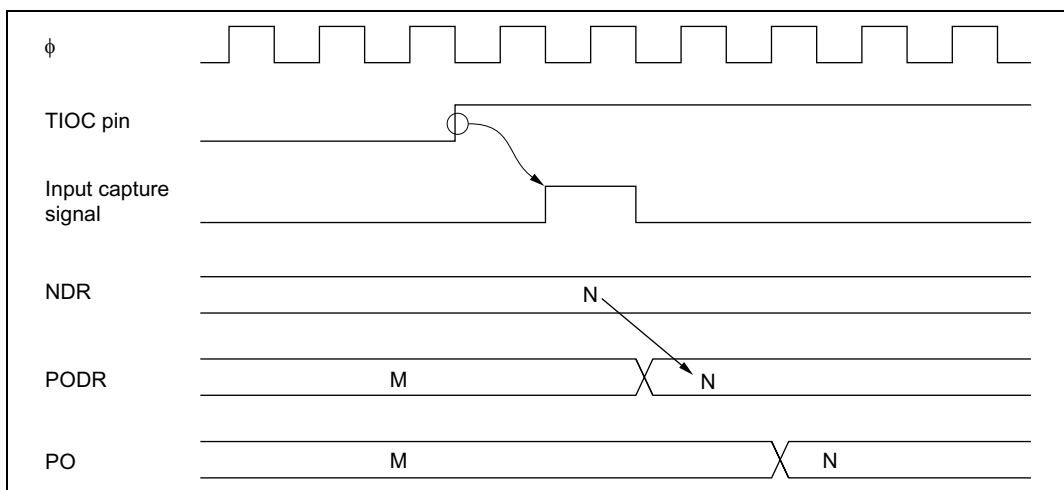

Figure 11-9 Pulse Output Triggered by Input Capture (Example)

11.4 Usage Notes

Operation of Pulse Output Pins: Pins PO8 to PO15 are also used for other peripheral functions such as the TPU. When output by another peripheral function is enabled, the corresponding pins cannot be used for pulse output. Note, however, that data transfer from NDR bits to PODR bits takes place, regardless of the usage of the pins.

Pin functions should be changed only under conditions in which the output trigger event will not occur.

Note on Non-Overlapping Output: During non-overlapping operation, the transfer of NDR bit values to PODR bits takes place as follows.

- NDR bits are always transferred to PODR bits at compare match A.
- At compare match B, NDR bits are transferred only if their value is 0. Bits are not transferred if their value is 1.

Figure 11-10 illustrates the non-overlapping pulse output operation.

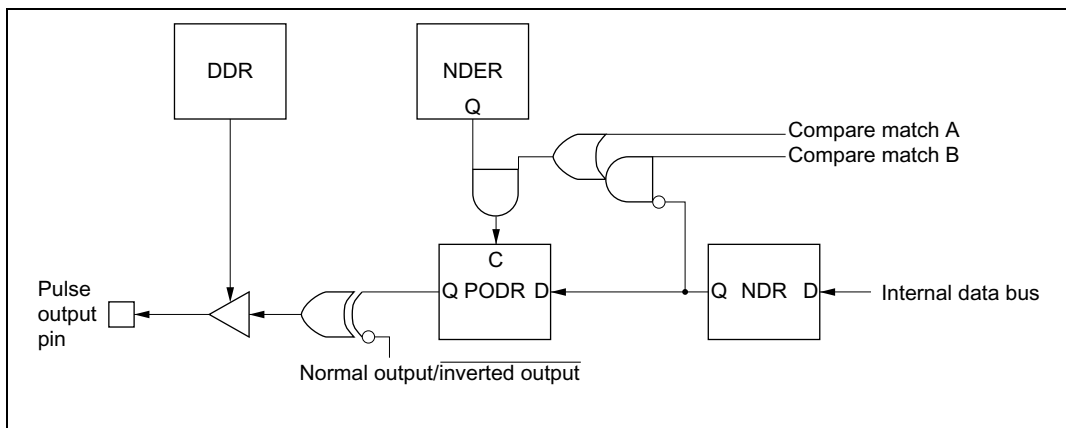

Figure 11-10 Non-Overlapping Pulse Output

Therefore, 0 data can be transferred ahead of 1 data by making compare match B occur before compare match A. The NDR contents should not be altered during the interval from compare match B to compare match A (the non-overlap margin).

This can be accomplished by having the TGIA interrupt handling routine write the next data in NDR, or by having the TGIA interrupt activate the DTC. Note, however, that the next data must be written before the next compare match B occurs.

Figure 11-11 shows the timing of this operation.

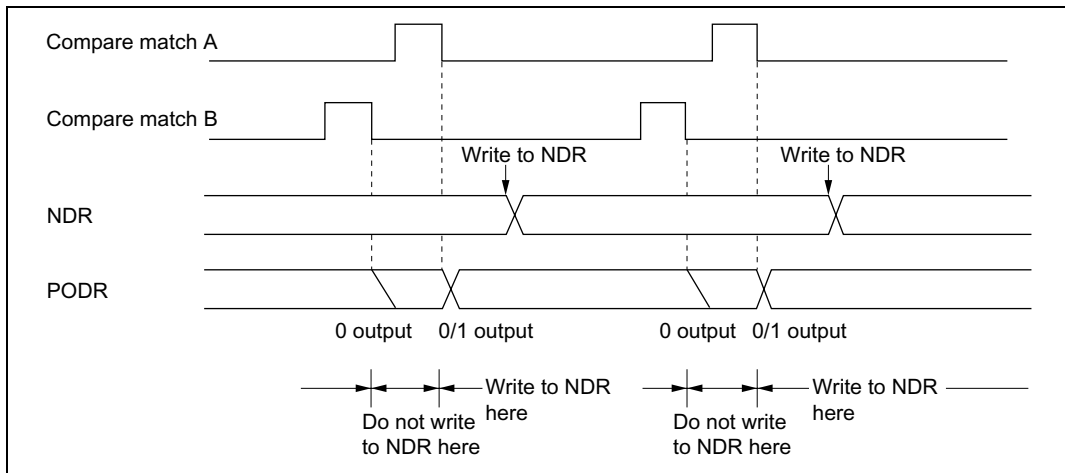

Figure 11-11 Non-Overlapping Operation and NDR Write Timing

Section 12 Watchdog Timer

12.1 Overview

The chip has two channel inbuilt watchdog timers (WDT0/WDT1). The WDT can also generate an internal reset signal for the chip if a system crash prevents the CPU from writing to the timer counter, allowing it to overflow.

When this watchdog function is not needed, the WDT can be used as an interval timer. In interval timer operation, an interval timer interrupt is generated each time the counter overflows.

12.1.1 Features

WDT features are listed below.

- Switchable between watchdog timer mode and interval timer mode
- An internal reset can be issued if the timer counter overflows
 - In the watchdog timer mode, the WDT can generate an internal reset
- Interrupt generation when in interval timer mode
 - If the counter overflows, the WDT generates an interval timer interrupt
- WDT0 and WDT1 respectively allow eight and sixteen types^{*1} of counter input clock to be selected
 - The maximum interval of the WDT is given as a system clock cycle $\times 131072 \times 256$
 - A subclock^{*2} may be selected for the input counter of WDT1
 - Where a subclock is selected, the maximum interval is given as a subclock cycle $\times 256 \times 256$

Notes: 1. Other than the U-mask and W-mask versions, and H8S/2635 Group have eight types of counter input clock as well as WDT0.

2. Subclock functions (subactive mode, subsleep mode, and watch mode) are available in the U-mask and W-mask versions, and H8S/2635 Group only.
See section 22A.7, Subclock Oscillator, for the method of fixing pins when OSC1 and OSC2 are not used. The H8S/2639 and H8S/2635 Groups have no OSC1 and OSC2 pins.

12.1.2 Block Diagram

Figures 12-1 (a) and 12-1 (b) show block diagrams of the WDT.

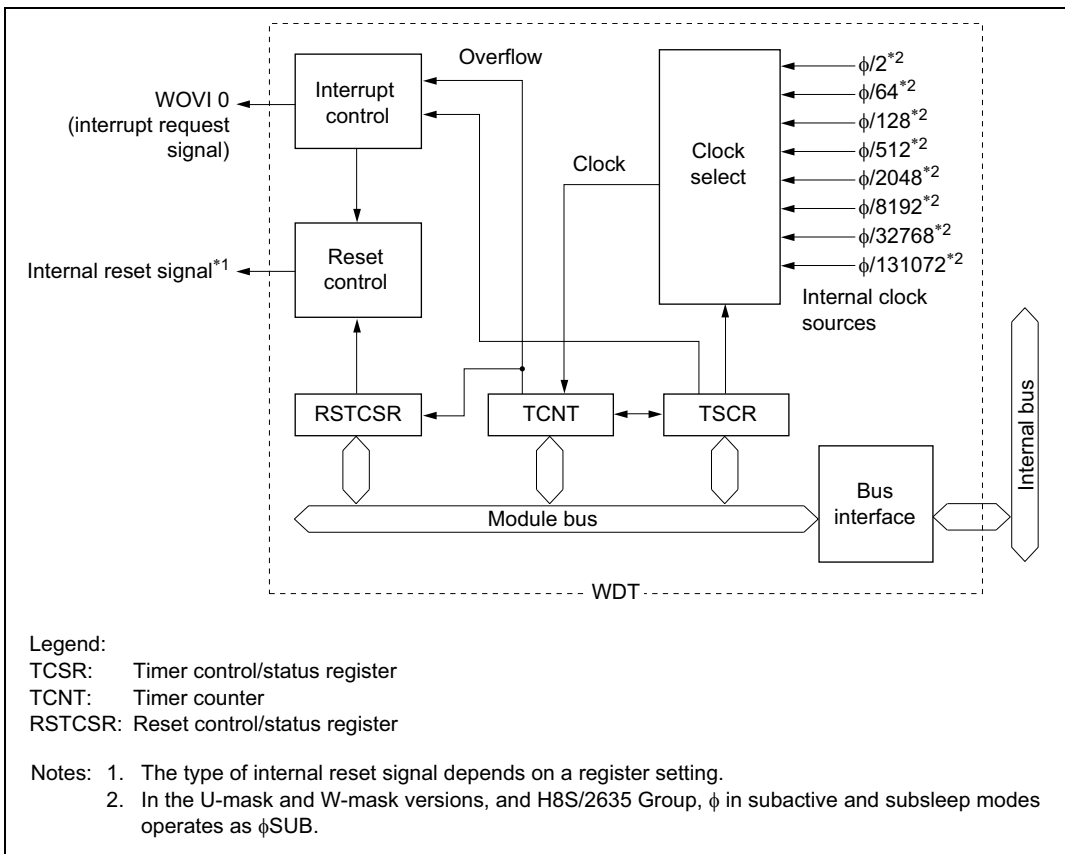

Figure 12-1 (a) Block Diagram of WDT0

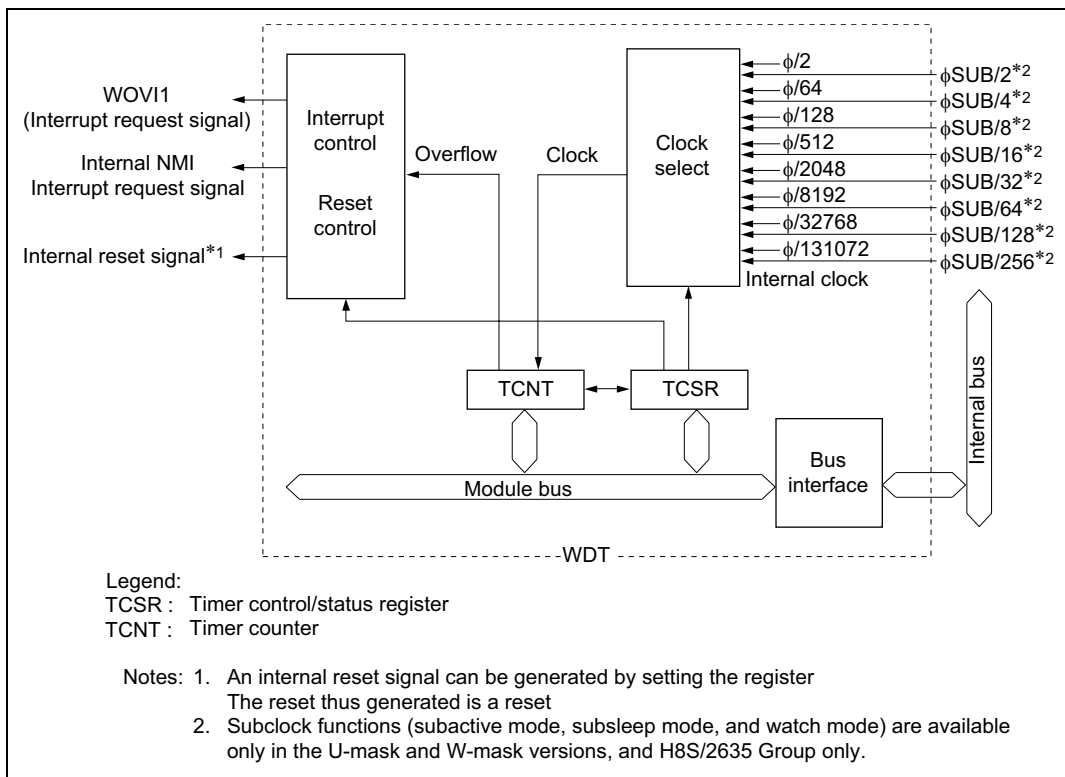

Figure 12-1 (b) Block Diagram of WDT1

12.1.3 Pin Configuration

There are no pins related to the WDT.

12.1.4 Register Configuration

The WDT has five registers, as summarized in table 12-1. These registers control clock selection, WDT mode switching, and the reset signal.

Table 12-1 WDT Registers

Channel Name	Abbreviation	R/W	Initial Value	Address* ¹		
				Write* ²	Read	
0	Timer control/status register 0	TCSR0	R/(W)* ³	H'18	H'FF74	H'FF74
	Timer counter 0	TCNT0	R/W	H'00	H'FF74	H'FF75
	Reset control/status register	RSTCSR0	R/(W)* ³	H'1F	H'FF76	H'FF77
1	Timer control/status register 1	TCSR1	R/(W)* ³	H'00	H'FFA2	H'FFA2
	Timer counter 1	TCNT1	R/W	H'00	H'FFA2	H'FFA3

Notes: 1. Lower 16 bits of the address.

2. For details of write operations, see section 12.2.4, Notes on Register Access.

3. Only a write of 0 is permitted to bit 7, to clear the flag.

12.2 Register Descriptions

12.2.1 Timer Counter (TCNT)

Bit	:	7	6	5	4	3	2	1	0										
		<table border="1" style="width: 100%; height: 20px; border-collapse: collapse;"> <tr> <td style="width: 12.5%;"></td> <td style="width: 12.5%;"></td> <td style="width: 12.5%;"></td> <td style="width: 12.5%;"></td> <td style="width: 12.5%;"></td> <td style="width: 12.5%;"></td> <td style="width: 12.5%;"></td> <td style="width: 12.5%;"></td> <td style="width: 12.5%;"></td> <td style="width: 12.5%;"></td> </tr> </table>																	
Initial value :		0	0	0	0	0	0	0	0										
R/W	:	R/W	R/W	R/W	R/W	R/W	R/W	R/W	R/W										

TCNT is an 8-bit readable/writable* up-counter.

When the TME bit is set to 1 in TCSR, TCNT starts counting pulses generated from the internal clock source selected by bits CKS2 to CKS0 in TCSR. When the count overflows (changes from H'FF to H'00), an interval timer interrupt (WOVI) is generated, depending on the mode selected by the WT/IT bit in TCSR.

TCNT is initialized to H'00 by a reset, in hardware standby mode, or when the TME bit is cleared to 0. It is not initialized in software standby mode.

Note: * TCNT is write-protected by a password to prevent accidental overwriting. For details see section 12.2.4, Notes on Register Access.

12.2.2 Timer Control/Status Register (TCSR)

TCSR0

Bit	:	7	6	5	4	3	2	1	0
		OVF	WT/ \overline{IT}	TME	—	—	CKS2	CKS1	CKS0
Initial value :		0	0	0	1	1	0	0	0
R/W	:	R/(W)*	R/W	R/W	—	—	R/W	R/W	R/W

Note: * Only a 0 may be written to this bit to clear the flag.

TCSR1

Bit	:	7	6	5	4	3	2	1	0
		OVF	WT/ \overline{IT}	TME	PSS* ²	RST/ \overline{NMI}	CKS2	CKS1	CKS0
Initial value :		0	0	0	0	0	0	0	0
R/W	:	R/(W)* ¹	R/W	R/W	R/W	R/W	R/W	R/W	R/W

- Notes: 1. Only a 0 may be written to this bit to clear the flag.
 2. Subclock functions (subactive mode, subsleep mode, and watch mode) are available in the U-mask and W-mask versions, and H8S/2635 Group only.

TCSR is an 8-bit readable/writable* register. Its functions include selecting the clock source to be input to TCNT, and the timer mode.

TCSR0 (TCSR1) is initialized to H'18 (H'00) by a reset and in hardware standby mode. It is not initialized in software standby mode.

Note: * TCSR is write-protected by a password to prevent accidental overwriting. For details see section 12.2.4, Notes on Register Access.

Bit 7—Overflow Flag (OVF): Indicates that TCNT has overflowed from H'FF to H'00.

Bit 7 OVF	Description
0	[Clearing conditions] (Initial value) <ul style="list-style-type: none"> • Cleared when 0 is written to the TME bit (Only applies to WDT1) • Cleared by reading TCSR* when OVF = 1, then writing 0 to OVF
1	[Setting condition] <ul style="list-style-type: none"> • When TCNT overflows (changes from H'FF to H'00) When internal reset request generation is selected in watchdog timer mode, OVF is cleared automatically by the internal reset.

Note: *When interval timer interrupts are disabled and OVF is polled, read the OVF = 1 state at least twice.

In the interval timer mode, the OVF flag can be cleared in the interval timer interrupt routine by writing 0 to OVF after reading TCSR when OVF is set to 1, in accordance with the conditions for clearing the OVF flag.

However, when attempting to poll the OVF flag when interval timer interrupts are prohibited the OVF value will not be recognized as 1 (even though it is set to 1) if there is a conflict between the timing used to set the OVF flag and the timing used to read the OVF flag.

In such cases it is possible to completely satisfy the conditions for clearing the OVF flag by reading OVF two or more times while its value is 1. In a situation such as the above, the OVF flag should be read two or more times while its value is 1 and then cleared.

Bit 6—Timer Mode Select (WT/IT): Selects whether the WDT is used as a watchdog timer or interval timer. This selection determines whether WDT0 issues an internal reset when TCNT overflows while bit RSTE of the reset control/status register (RSTCSR) is set to 1. In the interval timer mode, WDT0 sends a WOVI interrupt request to the CPU. WDT1, on the other hand, requests a reset or an NMI interrupt from the CPU if the watchdog timer mode is chosen, whereas it requests a WOVI interrupt from the CPU if the interval timer mode is chosen.

WDT0 Mode Select**TCSR0**

WT/\overline{IT}	Description
0	Interval timer mode: WDT0 requests an interval timer interrupt (WOVI) from the CPU when the TCNT overflows (Initial value)
1	Watchdog timer mode: A reset is issued when the TCNT overflows if the RSTE bit of RSTCSR is set to 1*

Note: * For details see section 12.2.3, Reset Control/Status Register (RSTCSR).

WDT1 Mode Select**TCSR1**

WT/\overline{IT}	Description
0	Interval timer mode: WDT1 requests an interval timer interrupt (WOVI) from the CPU when the TCNT overflows (Initial value)
1	Watchdog timer mode: WDT1 requests a reset or an NMI interrupt from the CPU when the TCNT overflows

Bit 5—Timer Enable (TME): Selects whether TCNT runs or is halted.

Bit 5

TME	Description
0	TCNT is initialized to H'00 and halted (Initial value)
1	TCNT counts

WDT0 TCSR Bit 4—Reserved Bit: A read operation on this bit always causes a 1 to be read out. Every write operation on this bit is invalidated.

WDT1 TCSR Bit 4—Prescaler Select (PSS): This bit is used to select an input clock source for the TCNT of WDT1.

See the descriptions of Clock Select 2 to 0 for details.

WDT1 TCSR**Bit 4**

PSS	Description
0	The TCNT counts frequency-division clock pulses of the ϕ based prescaler (PSM) (Initial value)
1	The TCNT counts frequency-division clock pulses of the ϕ SUB*-based prescaler (PSS)

Note: * Subclock functions (subactive mode, subsleep mode, and watch mode) are available only in the U-mask and W-mask versions, but are not available in the other versions.

WDT0 TCSR Bit 3—Reserved: A read operation on this bit always causes a 1 to be read out. Every write operation on this bit is invalidated.

WDT1 TCSR Bit 3—Reset or NMI ($\overline{\text{RST}}/\overline{\text{NMI}}$): This bit is used to choose between an internal reset request and an NMI request when the TCNT overflows during the watchdog timer mode.

Bit 3

$\overline{\text{RST}}/\overline{\text{NMI}}$	Description
0	NMI request (Initial value)
1	Internal reset request

Bits 2 to 0—Clock Select 2 to 0 (CKS2 to CKS0): These bits select one of eight internal clock sources, obtained by dividing the system clock (ϕ) or subclock* (ϕ SUB), for input to TCNT.

Note: * Subclock functions (subactive mode, subsleep mode, and watch mode) are available in the U-mask and W-mask versions, and H8S/2635 Group only.
These functions cannot be used with the other versions, and in them the PSS bit is reserved. Only 0 should be written to this bit.

WDT0 Input Clock Select

Bit 2 CKS2	Bit 1 CKS1	Bit 0 CKS0	Description	
			Clock	Overflow Period ^{*1} (where $\phi = 20$ MHz)
0	0	0	$\phi/2^{*2}$ (initial value)	25.6 μ s
		1	$\phi/64^{*2}$	819.2 μ s
	1	0	$\phi/128^{*2}$	1.6 ms
		1	$\phi/512^{*2}$	6.6 ms
1	0	0	$\phi/2048^{*2}$	26.2 ms
		1	$\phi/8192^{*2}$	104.9 ms
	1	0	$\phi/32768^{*2}$	419.4 ms
		1	$\phi/131072^{*2}$	1.68 s

- Notes: 1. An overflow period is the time interval between the start of counting up from H'00 on the TCNT and the occurrence of a TCNT overflow.
2. In the U-mask and W-mask versions, and H8S/2635 Group, ϕ in subactive and subsleep modes operates as ϕ SUB.

WDT1 Input Clock Select

Bit 4 PSS ^{*2}	Bit 2 CKS2	Bit 1 CKS1	Bit 0 CKS0	Description			
				Clock	Overflow Period ^{*1} (where $\phi = 20$ MHz) (where $\phi_{SUB}^{*2} = 32.768$ kHz)		
0	0	0	0	$\phi/2$ (initial value)	25.6 μ s		
			1	$\phi/64$	819.2 μ s		
			1	0	$\phi/128$	1.6 ms	
				1	$\phi/512$	6.6 ms	
			1	0	0	$\phi/2048$	26.2 ms
					1	$\phi/8192$	104.9 ms
1	0	0	$\phi/32768$	419.4 ms			
		1	$\phi/131072$	1.68 s			
1	0	0	0	$\phi_{SUB}/2^{*2}$	15.6 ms		
			1	$\phi_{SUB}/4^{*2}$	31.3 ms		
			1	0	$\phi_{SUB}/8^{*2}$	62.5 ms	
				1	$\phi_{SUB}/16^{*2}$	125 ms	
			1	0	0	$\phi_{SUB}/32^{*2}$	250 ms
	1	$\phi_{SUB}/64^{*2}$			500 ms		
	1	0	0	$\phi_{SUB}/128^{*2}$	1 s		
			1	$\phi_{SUB}/256^{*2}$	2 s		

- Notes: 1. An overflow period is the time interval between the start of counting up from H'00 on the TCNT and the occurrence of a TCNT overflow.
2. Subclock functions (subactive mode, subsleep mode, and watch mode) are available in the U-mask and W-mask versions, and H8S/2635 Group only.
These functions cannot be used with the other versions, therefore PSS bit is reserved.
0 should be written when writing.

12.2.3 Reset Control/Status Register (RSTCSR)

Bit	:	7	6	5	4	3	2	1	0
		WOVF	RSTE	RSTS	—	—	—	—	—
Initial value :		0	0	0	1	1	1	1	1
R/W	:	R/(W)*	R/W	R/W	—	—	—	—	—

Note: * Can only be written with 0 for flag clearing.

RSTCSR is an 8-bit readable/writable* register that controls the generation of the internal reset signal when TCNT overflows, and selects the type of internal reset signal.

RSTCSR is initialized to H'1F by a reset signal from the $\overline{\text{RES}}$ pin, but not by the WDT internal reset signal caused by overflows.

Note: * RSTCSR is write-protected by a password to prevent accidental overwriting. For details see section 12.2.4, Notes on Register Access.

Bit 7—Watchdog Overflow Flag (WOVF): Indicates that TCNT has overflowed (changed from H'FF to H'00) during watchdog timer operation. This bit is not set in interval timer mode.

Bit 7

WOVF	Description
0	[Clearing condition] (Initial value) <ul style="list-style-type: none"> Cleared by reading RSTCSR when WOVF = 1, then writing 0 to WOVF
1	[Setting condition] <ul style="list-style-type: none"> Set when TCNT overflows (changed from H'FF to H'00) during watchdog timer operation

Bit 6—Reset Enable (RSTE): Specifies whether or not a reset signal is generated in the H8S/2636 if TCNT overflows during watchdog timer operation.

Bit 6

RSTE	Description
0	Reset signal is not generated if TCNT overflows* (Initial value)
1	Reset signal is generated if TCNT overflows

Note: * The modules within the chip are not reset, but TCNT and TCSR within the WDT are reset.

Bit 5—Reset Select (RSTS): Selects the type of internal reset generated if TCNT overflows during watchdog timer operation.

For details of the types of reset, see section 4, Exception Handling.

Bit 5 RSTS	Description	
0	Reset	(Initial value)
1	Do not set	

Bits 4 to 0—Reserved: Always read as 1 and cannot be modified.

12.2.4 Notes on Register Access

The watchdog timer's TCNT, TCSR, and RSTCSR registers differ from other registers in being more difficult to write to. The procedures for writing to and reading these registers are given below.

Writing to TCNT and TCSR: These registers must be written to by a word transfer instruction. They cannot be written to with byte instructions.

Figure 12-2 shows the format of data written to TCNT and TCSR. TCNT and TCSR both have the same write address. For a write to TCNT, the upper byte of the written word must contain H'5A and the lower byte must contain the write data. For a write to TCSR, the upper byte of the written word must contain H'A5 and the lower byte must contain the write data. This transfers the write data from the lower byte to TCNT or TCSR.

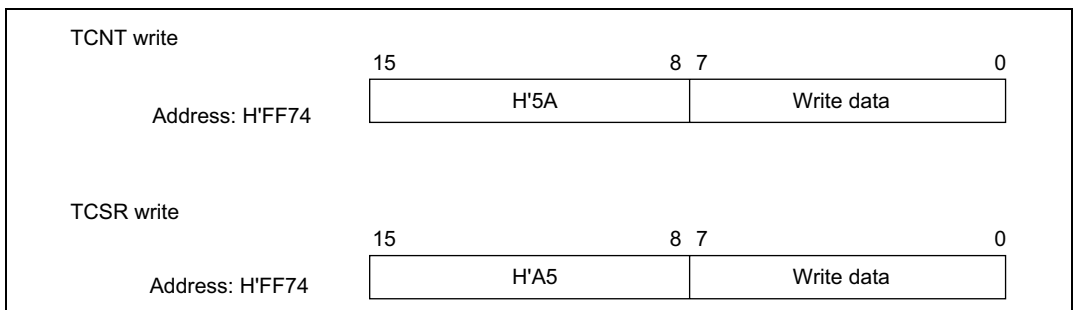

Figure 12-2 Format of Data Written to TCNT and TCSR (WDT0)

Writing to RSTCSR: RSTCSR must be written to by word transfer instruction to address H'FF76. It cannot be written to with byte instructions.

Figure 12-3 shows the format of data written to RSTCSR. The method of writing 0 to the WOVF bit differs from that for writing to the RSTE bit.

To write 0 to the WOVF bit, the write data must have H'A5 in the upper byte and H'00 in the lower byte. This clears the WOVF bit to 0, but has no effect on the RSTE bit. To write to the RSTE bit, the upper byte must contain H'5A and the lower byte must contain the write data. This writes the values in bits 6 and 5 of the lower byte into the RSTE bit, but has no effect on the WOVF bit.

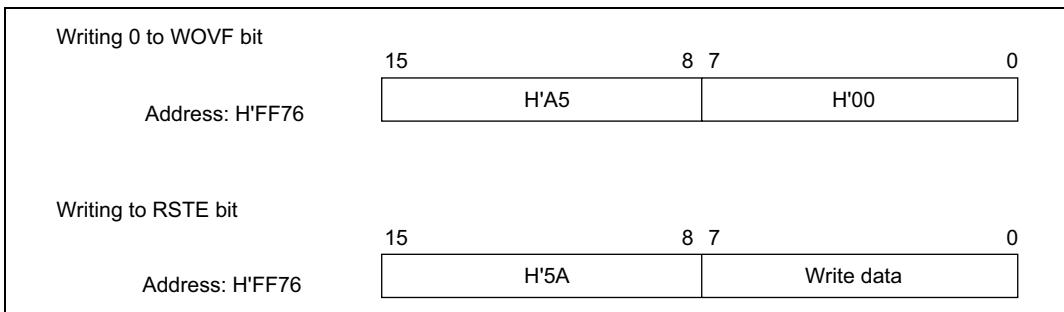

Figure 12-3 Format of Data Written to RSTCSR (WDT0)

Reading TCNT, TCSR, and RSTCSR (WDT0): These registers are read in the same way as other registers. The read addresses are H'FF74 for TCSR, H'FF75 for TCNT, and H'FF77 for RSTCSR.

12.3 Operation

12.3.1 Watchdog Timer Operation

To use the WDT as a watchdog timer, set the $\overline{WT/IT}$ bit in TCSR and the TME bit to 1. Software must prevent TCNT overflows by rewriting the TCNT value (normally by writing H'00) before overflow occurs. This ensures that TCNT does not overflow while the system is operating normally. If TCNT overflows without being rewritten because of a system malfunction or other error, an internal reset is issued, in the case of WDT0, if the RSTE bit in RSTCSR is set to 1.

If a reset caused by a signal input to the \overline{RES} pin occurs at the same time as a reset caused by a WDT overflow, the \overline{RES} pin reset has priority and the WOVF bit in RSTCSR is cleared to 0.

In the case of WDT1, the chip is reset, or an NMI interrupt request is generated, for 516 system clock periods (516ϕ) (515 or 516 clock periods when the clock source is ϕ/SUB^* ($PSS = 1$)). This is illustrated in figure 12-4 (b).

An NMI request from the watchdog timer and an interrupt request from the NMI pin are both treated as having the same vector. So, avoid handling an NMI request from the watchdog timer and an interrupt request from the NMI pin at the same time.

Note: * Subclock functions (subactive mode, subsleep mode, and watch mode) are available in the U-mask and W-mask versions, and H8S/2635 Group only. These functions cannot be used with the other versions.

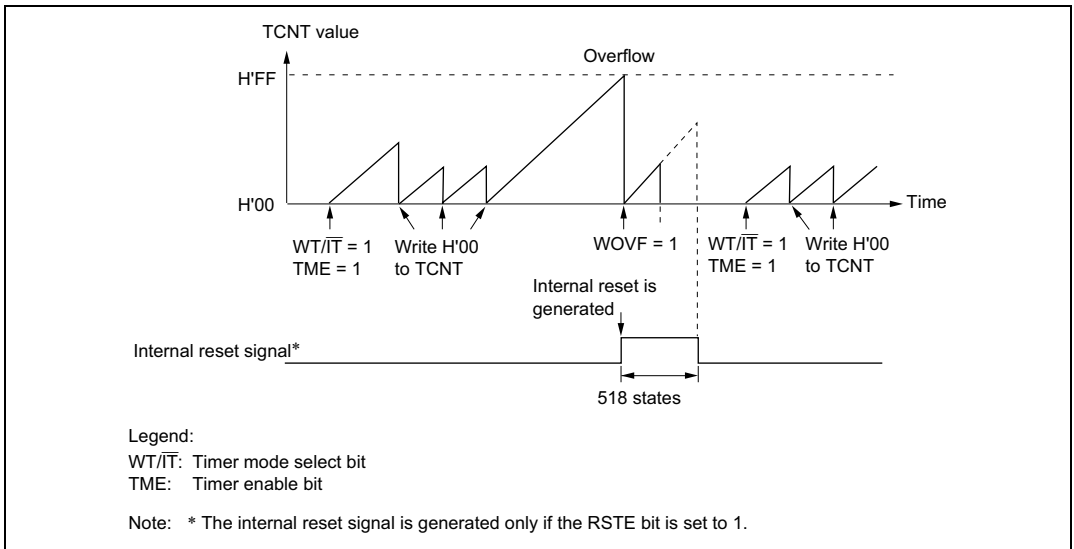

Figure 12-4 (a) WDT0 Watchdog Timer Operation

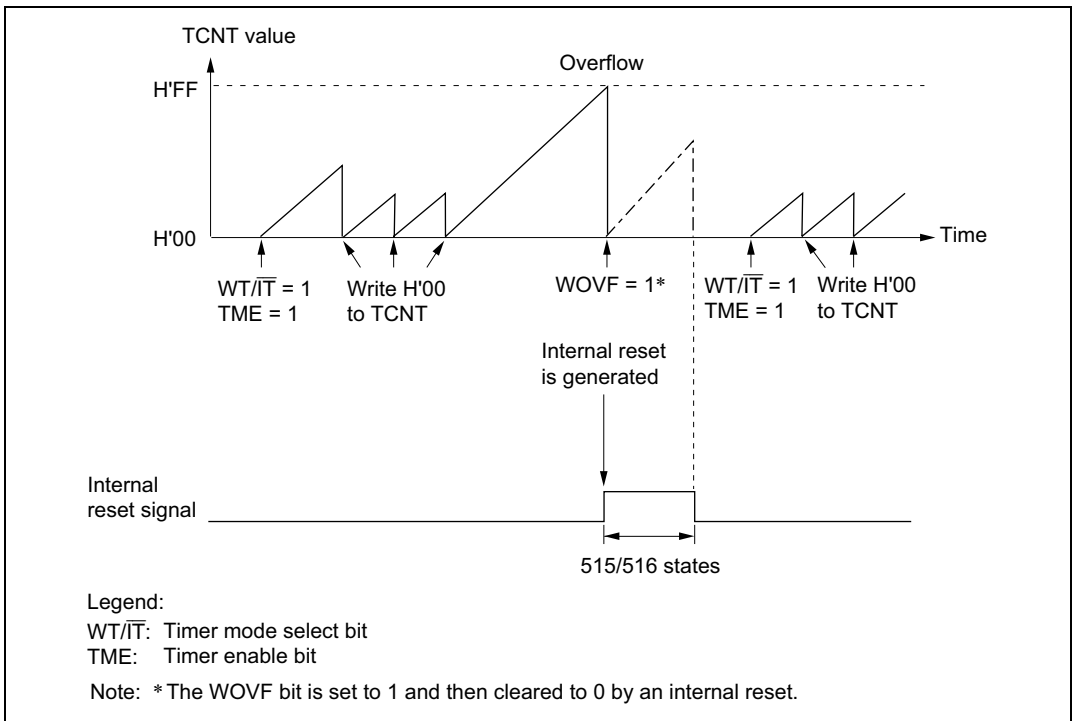

Figure 12-4 (b) WDT1 Watchdog Timer Operation

12.3.2 Interval Timer Operation

To use the WDT as an interval timer, clear the WT/\overline{IT} bit in TCSR to 0 and set the TME bit to 1. An interval timer interrupt (WOVI) is generated each time TCNT overflows, provided that the WDT is operating as an interval timer, as shown in figure 12-5. This function can be used to generate interrupt requests at regular intervals.

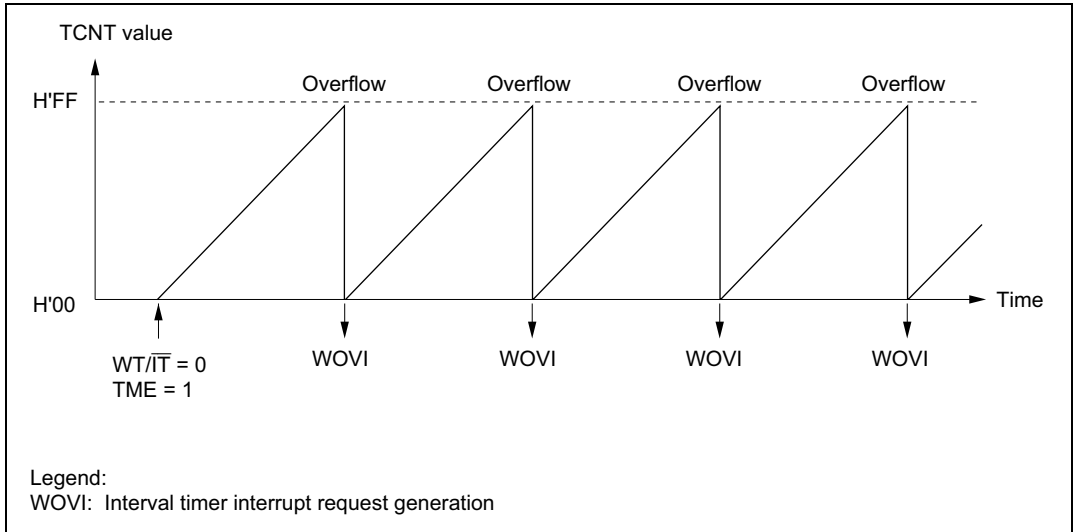

Figure 12-5 Interval Timer Operation

12.3.3 Timing of Setting Overflow Flag (OVF)

The OVF flag is set to 1 if TCNT overflows during interval timer operation. At the same time, an interval timer interrupt (WOVI) is requested. This timing is shown in figure 12-6.

With WDT1, the OVF bit of the TCSR is set to 1 and a simultaneous NMI interrupt is requested when the TCNT overflows if the NMI request has been chosen in the watchdog timer mode.

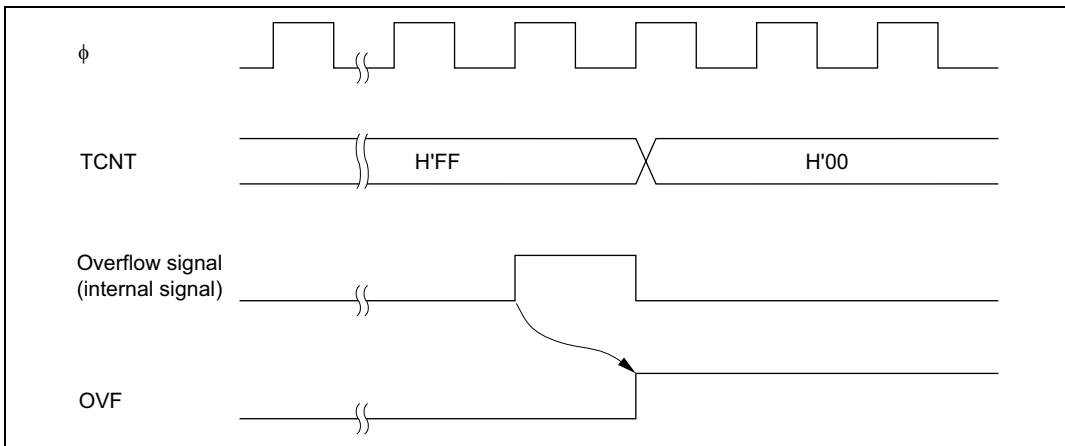

Figure 12-6 Timing of Setting of OVF

12.3.4 Timing of Setting of Watchdog Timer Overflow Flag (WOVF)

In the WDT0, the WOVF flag is set to 1 if TCNT overflows during watchdog timer operation. If TCNT overflows while the RSTE bit in RSTCSR is set to 1, an internal reset signal is generated for the entire chip. Figure 12-7 shows the timing in this case.

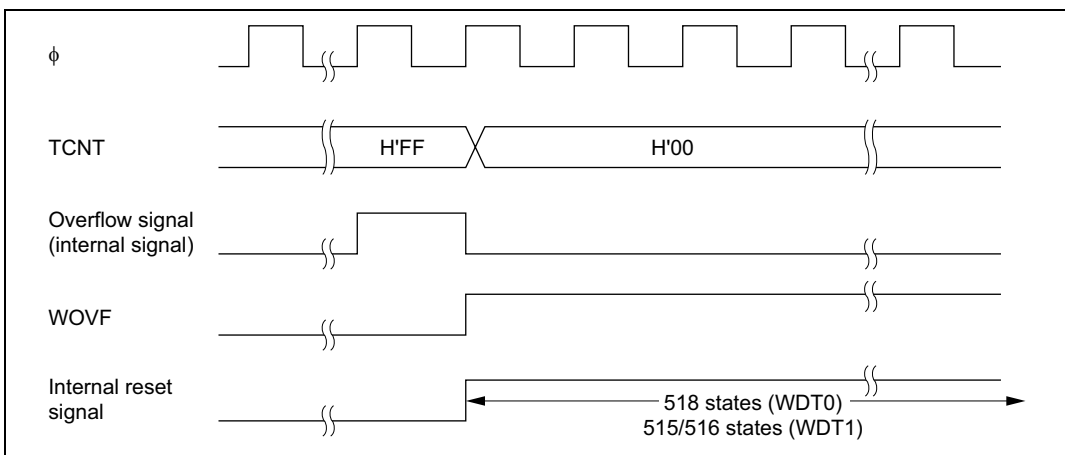

Figure 12-7 Timing of Setting of WOVF

12.4 Interrupts

During interval timer mode operation, an overflow generates an interval timer interrupt (WOVI). The interval timer interrupt is requested whenever the OVF flag is set to 1 in TCSR. OVF must be cleared to 0 in the interrupt handling routine.

If an NMI request has been chosen in the watchdog timer mode, an NMI request is generated when a TCNT overflow occurs.

12.5 Usage Notes

12.5.1 Contention between Timer Counter (TCNT) Write and Increment

If a timer counter clock pulse is generated during the T_2 state of a TCNT write cycle, the write takes priority and the timer counter is not incremented. Figure 12-8 shows this operation.

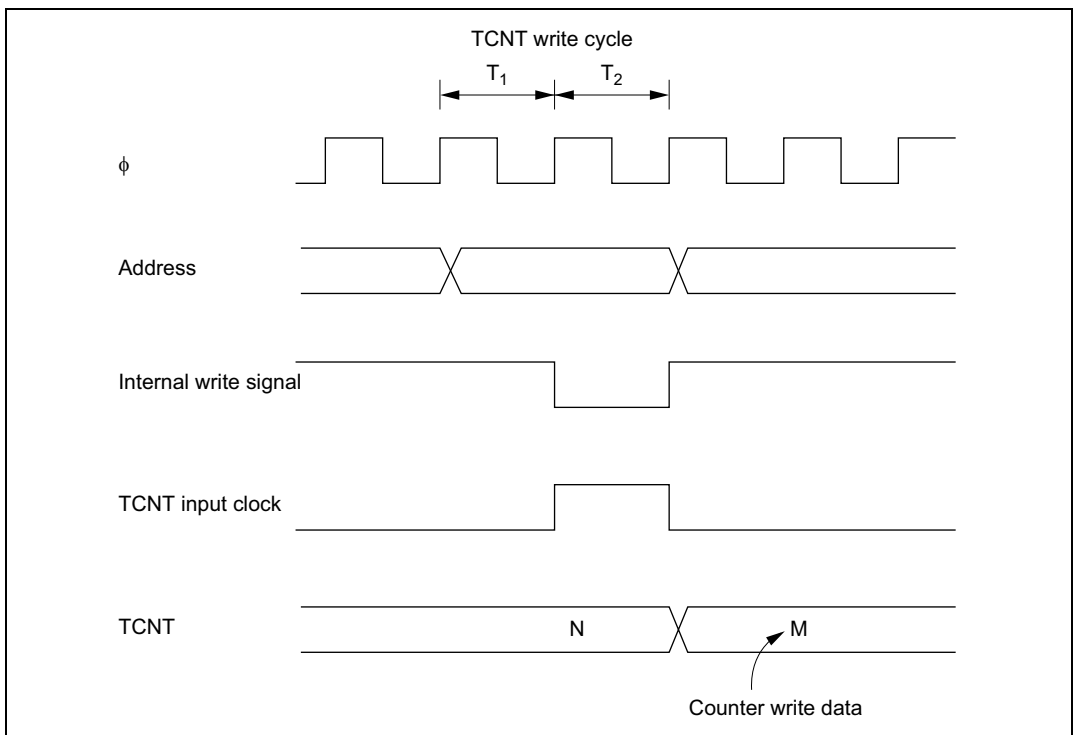

Figure 12-8 Contention between TCNT Write and Increment

12.5.2 Changing Value of PSS* and CKS2 to CKS0

If bits PSS and CKS2 to CKS0 in TCSR are written to while the WDT is operating, errors could occur in the incrementation. Software must stop the watchdog timer (by clearing the TME bit to 0) before changing the value of bits PSS* and CKS2 to CKS0.

Note: * Subclock functions (subactive mode, subsleep mode, and watch mode) are available in the U-mask and W-mask versions, and H8S/2635 Group only.
These functions cannot be used with the other versions.

12.5.3 Switching between Watchdog Timer Mode and Interval Timer Mode

If the mode is switched from watchdog timer to interval timer, or vice versa, while the WDT is operating, errors could occur in the incrementation. Software must stop the watchdog timer (by clearing the TME bit to 0) before switching the mode.

12.5.4 Internal Reset in Watchdog Timer Mode

The chip is not reset internally if TCNT overflows while the RSTE bit is cleared to 0 during watchdog timer operation, but TCNT and TSCR of the WDT are reset.

12.5.5 OVF Flag Clearing in Interval Timer Mode

If conflict occurs between OVF flag clearing and OVF flag reading in interval timer mode, the flag may not be cleared by writing 0 to OVF even though the OVF = 1 state has been read. When interval timer interrupts are disabled and the OVF flag is polled, for instance, and there is a possibility of conflict between OVF flag setting and reading, the OVF = 1 state should be read at least twice before writing 0 to OVF in order to clear the flag.

Section 13 Serial Communication Interface (SCI)

Note: The H8S/2635 Group is not equipped with a DTC.

13.1 Overview

The chip is equipped with 3 independent serial communication interface (SCI) channels. The SCI can handle both asynchronous and clocked synchronous serial communication. A function is also provided for serial communication between processors (multiprocessor communication function).

13.1.1 Features

SCI features are listed below.

- Choice of asynchronous or clocked synchronous serial communication mode
 - Asynchronous mode
 - Serial data communication executed using asynchronous system in which synchronization is achieved character by character
 - Serial data communication can be carried out with standard asynchronous communication chips such as a Universal Asynchronous Receiver/Transmitter (UART) or Asynchronous Communication Interface Adapter (ACIA)
 - A multiprocessor communication function is provided that enables serial data communication with a number of processors
 - Choice of 12 serial data transfer formats

Data length	: 7 or 8 bits
Stop bit length	: 1 or 2 bits
Parity	: Even, odd, or none
Multiprocessor bit	: 1 or 0
 - Receive error detection : Parity, overrun, and framing errors
 - Break detection : Break can be detected by reading the RxD pin level directly in case of a framing error
 - Clocked Synchronous mode
 - Serial data communication synchronized with a clock
 - Serial data communication can be carried out with other chips that have a synchronous communication function

- One serial data transfer format
 - Data length : 8 bits
- Receive error detection : Overrun errors detected
- Full-duplex communication capability
 - The transmitter and receiver are mutually independent, enabling transmission and reception to be executed simultaneously
 - Double-buffering is used in both the transmitter and the receiver, enabling continuous transmission and continuous reception of serial data
- Choice of LSB-first or MSB-first transfer
 - Can be selected regardless of the communication mode* (except in the case of asynchronous mode 7-bit data)
 - Note: * Descriptions in this section refer to LSB-first transfer.
- On-chip baud rate generator allows any bit rate to be selected
- Choice of serial clock source: internal clock from baud rate generator or external clock from SCK pin
- Four interrupt sources
 - Four interrupt sources — transmit-data-empty, transmit-end, receive-data-full, and receive error — that can issue requests independently
 - The transmit-data-empty interrupt and receive data full interrupts can activate the data transfer controller (DTC) to execute data transfer
- Module stop mode can be set
 - As the initial setting, SCI operation is halted. Register access is enabled by exiting module stop mode

13.1.2 Block Diagram

Figure 13-1 shows a block diagram of the SCI.

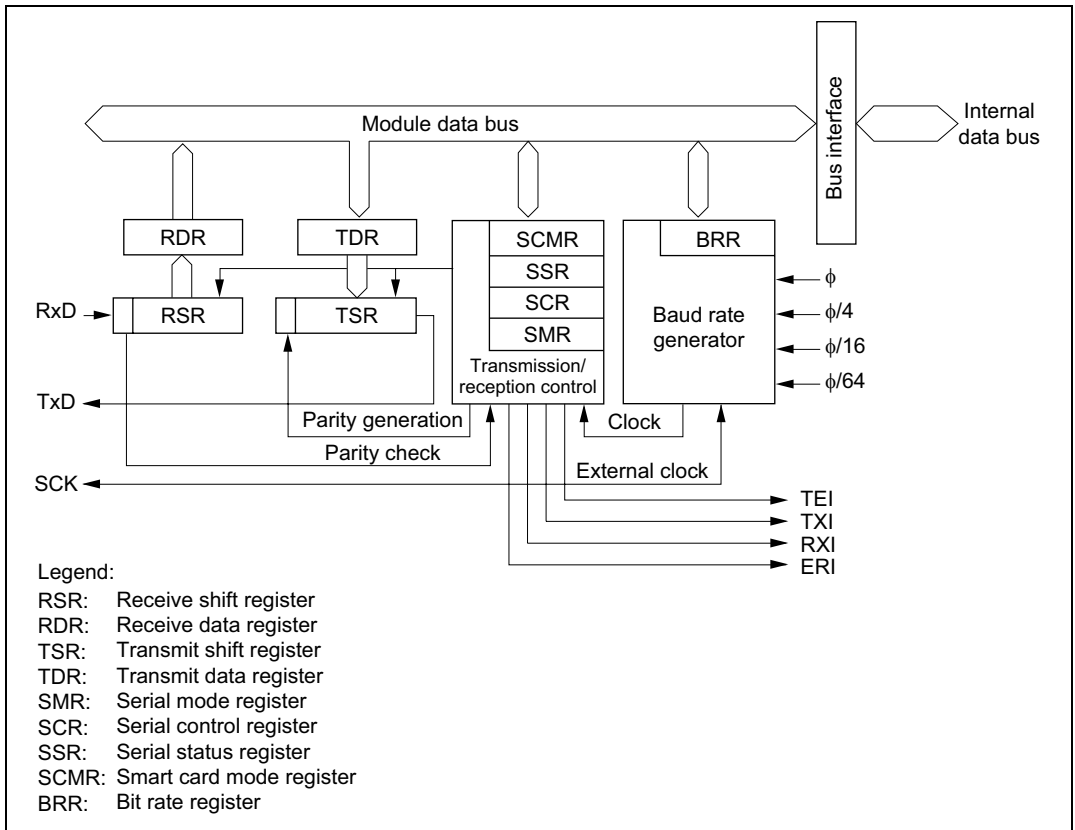

Figure 13-1 Block Diagram of SCI

13.1.3 Pin Configuration

Table 13-1 shows the serial pins for each SCI channel.

Table 13-1 SCI Pins

Channel	Pin Name	Symbol*	I/O	Function
0	Serial clock pin 0	SCK0	I/O	SCI0 clock input/output
	Receive data pin 0	RxD0	Input	SCI0 receive data input
	Transmit data pin 0	TxD0	Output	SCI0 transmit data output
1	Serial clock pin 1	SCK1	I/O	SCI1 clock input/output
	Receive data pin 1	RxD1	Input	SCI1 receive data input
	Transmit data pin 1	TxD1	Output	SCI1 transmit data output
2	Serial clock pin 2	SCK2	I/O	SCI2 clock input/output
	Receive data pin 2	RxD2	Input	SCI2 receive data input
	Transmit data pin 2	TxD2	Output	SCI2 transmit data output

Note: * Pin names SCK, RxD, and TxD are used in the text for all channels, omitting the channel designation.

13.1.4 Register Configuration

The SCI has the internal registers shown in table 13-2. These registers are used to specify asynchronous mode or clocked synchronous mode, the data format, and the bit rate, and to control transmitter/receiver.

Table 13-2 SCI Registers

Channel	Name	Abbreviation	R/W	Initial Value	Address*1
0	Serial mode register 0	SMR0	R/W	H'00	H'FF78
	Bit rate register 0	BRR0	R/W	H'FF	H'FF79
	Serial control register 0	SCR0	R/W	H'00	H'FF7A
	Transmit data register 0	TDR0	R/W	H'FF	H'FF7B
	Serial status register 0	SSR0	R/(W)*2	H'84	H'FF7C
	Receive data register 0	RDR0	R	H'00	H'FF7D
	Smart card mode register 0	SCMR0	R/W	H'F2	H'FF7E
1	Serial mode register 1	SMR1	R/W	H'00	H'FF80
	Bit rate register 1	BRR1	R/W	H'FF	H'FF81
	Serial control register 1	SCR1	R/W	H'00	H'FF82
	Transmit data register 1	TDR1	R/W	H'FF	H'FF83
	Serial status register 1	SSR1	R/(W)*2	H'84	H'FF84
	Receive data register 1	RDR1	R	H'00	H'FF85
	Smart card mode register 1	SCMR1	R/W	H'F2	H'FF86
2	Serial mode register 2	SMR2	R/W	H'00	H'FF88
	Bit rate register 2	BRR2	R/W	H'FF	H'FF89
	Serial control register 2	SCR2	R/W	H'00	H'FF8A
	Transmit data register 2	TDR2	R/W	H'FF	H'FF8B
	Serial status register 2	SSR2	R/(W)*2	H'84	H'FF8C
	Receive data register 2	RDR2	R	H'00	H'FF8D
	Smart card mode register 2	SCMR2	R/W	H'F2	H'FF8E
All	Module stop control register B	MSTPCRB	R/W	H'FF	H'FDE9

- Notes: 1. Lower 16 bits of the address.
 2. Can only be written with 0 for flag clearing.

13.2 Register Descriptions

13.2.1 Receive Shift Register (RSR)

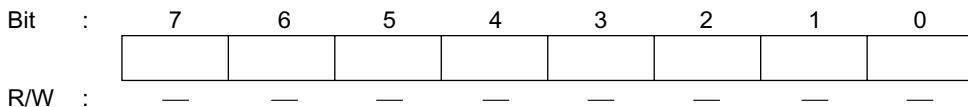

RSR is a register used to receive serial data.

The SCI sets serial data input from the RxD pin in RSR in the order received, starting with the LSB (bit 0), and converts it to parallel data. When one byte of data has been received, it is transferred to RDR automatically.

RSR cannot be directly read or written to by the CPU.

13.2.2 Receive Data Register (RDR)

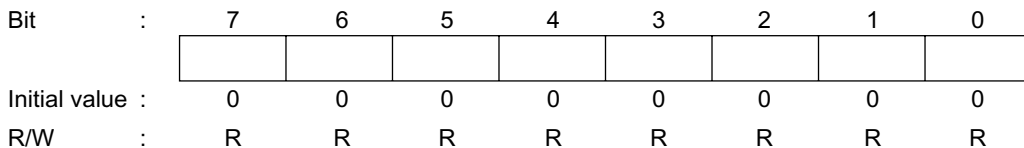

RDR is a register that stores received serial data.

When the SCI has received one byte of serial data, it transfers the received serial data from RSR to RDR where it is stored, and completes the receive operation. After this, RSR is receive-enabled.

Since RSR and RDR function as a double buffer in this way, enables continuous receive operations to be performed.

RDR is a read-only register, and cannot be written to by the CPU.

RDR is initialized to H'00 by a reset, in standby mode, watch mode*, subactive mode*, and subsleep mode* or module stop mode.

Note: * Subclock functions (subactive mode, subsleep mode, and watch mode) are available in the U-mask and W-mask versions, and H8S/2635 Group only. These functions cannot be used with the other versions.

13.2.3 Transmit Shift Register (TSR)

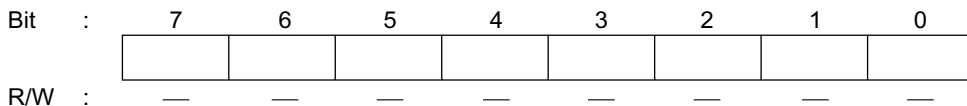

TSR is a register used to transmit serial data.

To perform serial data transmission, the SCI first transfers transmit data from TDR to TSR, then sends the data to the TxD pin starting with the LSB (bit 0).

When transmission of one byte is completed, the next transmit data is transferred from TDR to TSR, and transmission started, automatically. However, data transfer from TDR to TSR is not performed if the TDRE bit in SSR is set to 1.

TSR cannot be directly read or written to by the CPU.

13.2.4 Transmit Data Register (TDR)

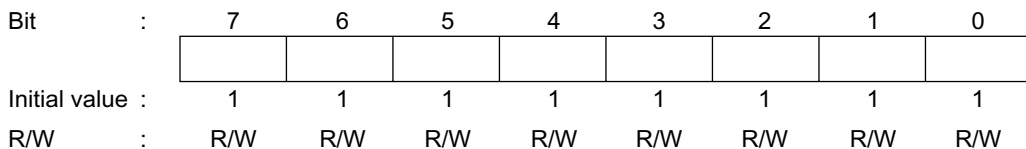

TDR is an 8-bit register that stores data for serial transmission.

When the SCI detects that TSR is empty, it transfers the transmit data written in TDR to TSR and starts serial transmission. Continuous serial transmission can be carried out by writing the next transmit data to TDR during serial transmission of the data in TSR.

TDR can be read or written to by the CPU at all times.

TDR is initialized to H'FF by a reset, in standby mode, watch mode^{*}, subactive mode^{*}, and subsleep mode^{*} or module stop mode.

Note: ^{*} Subclock functions (subactive mode, subsleep mode, and watch mode) are available in the U-mask and W-mask versions, and H8S/2635 Group only.

These functions cannot be used with the other versions.

13.2.5 Serial Mode Register (SMR)

Bit	:	7	6	5	4	3	2	1	0
		C/ \bar{A}	CHR	PE	O/ \bar{E}	STOP	MP	CKS1	CKS0
Initial value	:	0	0	0	0	0	0	0	0
R/W	:	R/W	R/W	R/W	R/W	R/W	R/W	R/W	R/W

SMR is an 8-bit register used to set the SCI's serial transfer format and select the baud rate generator clock source.

SMR can be read or written to by the CPU at all times.

SMR is initialized to H'00 by a reset and in hardware standby mode.

Bit 7—Communication Mode (C/ \bar{A}): Selects asynchronous mode or clocked synchronous mode as the SCI operating mode.

Bit 7

C/ \bar{A}	Description
0	Asynchronous mode (Initial value)
1	Clocked synchronous mode

Bit 6—Character Length (CHR): Selects 7 or 8 bits as the data length in asynchronous mode. In clocked synchronous mode, a fixed data length of 8 bits is used regardless of the CHR setting.

Bit 6

CHR	Description
0	8-bit data (Initial value)
1	7-bit data*

Note: * When 7-bit data is selected, the MSB (bit 7) of TDR is not transmitted, and it is not possible to choose between LSB-first or MSB-first transfer.

Bit 5—Parity Enable (PE): In asynchronous mode, selects whether or not parity bit addition is performed in transmission, and parity bit checking in reception. In clocked synchronous mode with a multiprocessor format, parity bit addition and checking is not performed, regardless of the PE bit setting.

Bit 5

PE	Description
0	Parity bit addition and checking disabled (Initial value)
1	Parity bit addition and checking enabled*

Note:* When the PE bit is set to 1, the parity (even or odd) specified by the O/\bar{E} bit is added to transmit data before transmission. In reception, the parity bit is checked for the parity (even or odd) specified by the O/\bar{E} bit.

Bit 4—Parity Mode (O/\bar{E}): Selects either even or odd parity for use in parity addition and checking.

The O/\bar{E} bit setting is only valid when the PE bit is set to 1, enabling parity bit addition and checking, in asynchronous mode. The O/\bar{E} bit setting is invalid in clocked synchronous mode, when parity addition and checking is disabled in asynchronous mode, and when a multiprocessor format is used.

Bit 4

O/\bar{E}	Description
0	Even parity* ¹ (Initial value)
1	Odd parity* ²

Notes: 1. When even parity is set, parity bit addition is performed in transmission so that the total number of 1 bits in the transmit character plus the parity bit is even.

In reception, a check is performed to see if the total number of 1 bits in the receive character plus the parity bit is even.

2. When odd parity is set, parity bit addition is performed in transmission so that the total number of 1 bits in the transmit character plus the parity bit is odd.

In reception, a check is performed to see if the total number of 1 bits in the receive character plus the parity bit is odd.

Bit 3—Stop Bit Length (STOP): Selects 1 or 2 bits as the stop bit length in asynchronous mode. The STOP bits setting is only valid in asynchronous mode. If clocked synchronous mode is set the STOP bit setting is invalid since stop bits are not added.

Bit 3

STOP	Description
0	1 stop bit: In transmission, a single 1 bit (stop bit) is added to the end of a transmit character before it is sent (Initial value)
1	2 stop bits: In transmission, two 1 bits (stop bits) are added to the end of a transmit character before it is sent

In reception, only the first stop bit is checked, regardless of the STOP bit setting. If the second stop bit is 1, it is treated as a stop bit; if it is 0, it is treated as the start bit of the next transmit character.

Bit 2—Multiprocessor Mode (MP): Selects multiprocessor format. When multiprocessor format is selected, the PE bit and O/ \bar{E} bit parity settings are invalid. The MP bit setting is only valid in asynchronous mode; it is invalid in clocked synchronous mode.

For details of the multiprocessor communication function, see section 13.3.3, Multiprocessor Communication Function.

Bit 2

MP	Description
0	Multiprocessor function disabled (Initial value)
1	Multiprocessor format selected

Bits 1 and 0—Clock Select 1 and 0 (CKS1, CKS0): These bits select the clock source for the baud rate generator. The clock source can be selected from ϕ , $\phi/4$, $\phi/16$, and $\phi/64$, according to the setting of bits CKS1 and CKS0.

For the relation between the clock source, the bit rate register setting, and the baud rate, see section 13.2.8, Bit Rate Register (BRR).

Bit 1	Bit 0	Description
CKS1	CKS0	
0	0	ϕ clock (Initial value)
	1	$\phi/4$ clock
1	0	$\phi/16$ clock
	1	$\phi/64$ clock

13.2.6 Serial Control Register (SCR)

Bit	7	6	5	4	3	2	1	0
	TIE	RIE	TE	RE	MPIE	TEIE	CKE1	CKE0
Initial value :	0	0	0	0	0	0	0	0
R/W :	R/W	R/W	R/W	R/W	R/W	R/W	R/W	R/W

SCR is a register that performs enabling or disabling of SCI transfer operations, serial clock output in asynchronous mode, and interrupt requests, and selection of the serial clock source.

SCR can be read or written to by the CPU at all times.

SCR is initialized to H'00 by a reset and in standby mode.

Bit 7—Transmit Interrupt Enable (TIE): Enables or disables transmit data empty interrupt (TXI) request generation when serial transmit data is transferred from TDR to TSR and the TDRE flag in SSR is set to 1.

Bit 7

TIE	Description
0	Transmit data empty interrupt (TXI) requests disabled* (Initial value)
1	Transmit data empty interrupt (TXI) requests enabled

Note:* TXI interrupt request cancellation can be performed by reading 1 from the TDRE flag, then clearing it to 0, or clearing the TIE bit to 0.

Bit 6—Receive Interrupt Enable (RIE): Enables or disables receive data full interrupt (RXI) request and receive error interrupt (ERI) request generation when serial receive data is transferred from RSR to RDR and the RDRF flag in SSR is set to 1.

Bit 6

RIE	Description
0	Receive data full interrupt (RXI) request and receive error interrupt (ERI) request disabled* (Initial value)
1	Receive data full interrupt (RXI) request and receive error interrupt (ERI) request enabled

Note:* RXI and ERI interrupt request cancellation can be performed by reading 1 from the RDRF flag, or the FER, PER, or ORER flag, then clearing the flag to 0, or clearing the RIE bit to 0.

Bit 5—Transmit Enable (TE): Enables or disables the start of serial transmission by the SCI.

Bit 5

TE	Description
0	Transmission disabled* ¹ (Initial value)
1	Transmission enabled* ²

Notes: 1. The TDRE flag in SSR is fixed at 1.

2. In this state, serial transmission is started when transmit data is written to TDR and the TDRE flag in SSR is cleared to 0.

SMR setting must be performed to decide the transfer format before setting the TE bit to 1.

Bit 4—Receive Enable (RE): Enables or disables the start of serial reception by the SCI.

Bit 4

RE	Description
0	Reception disabled* ¹ (Initial value)
1	Reception enabled* ²

Notes: 1. Clearing the RE bit to 0 does not affect the RDRF, FER, PER, and ORER flags, which retain their states.

2. Serial reception is started in this state when a start bit is detected in asynchronous mode or serial clock input is detected in clocked synchronous mode.

SMR setting must be performed to decide the transfer format before setting the RE bit to 1.

Bit 3—Multiprocessor Interrupt Enable (MPIE): Enables or disables multiprocessor interrupts. The MPIE bit setting is only valid in asynchronous mode when the MP bit in SMR is set to 1.

The MPIE bit setting is invalid in clocked synchronous mode or when the MP bit is cleared to 0.

Bit 3

MPIE	Description
0	Multiprocessor interrupts disabled (normal reception performed) (Initial value) [Clearing conditions] <ul style="list-style-type: none"> • When the MPIE bit is cleared to 0 • When MPB= 1 data is received
1	Multiprocessor interrupts enabled* Receive interrupt (RXI) requests, receive error interrupt (ERI) requests, and setting of the RDRF, FER, and ORER flags in SSR are disabled until data with the multiprocessor bit set to 1 is received.

Note: *When receive data including MPB = 0 is received, receive data transfer from RSR to RDR, receive error detection, and setting of the RDRF, FER, and ORER flags in SSR, is not performed. When receive data including MPB = 1 is received, the MPB bit in SSR is set to 1, the MPIE bit is cleared to 0 automatically, and generation of RXI and ERI interrupts (when the TIE and RIE bits in SCR are set to 1) and FER and ORER flag setting is enabled.

Bit 2—Transmit End Interrupt Enable (TEIE): Enables or disables transmit end interrupt (TEI) request generation when there is no valid transmit data in TDR in MSB data transmission.

Bit 2

TEIE	Description
0	Transmit end interrupt (TEI) request disabled* (Initial value)
1	Transmit end interrupt (TEI) request enabled*

Note: *TEI cancellation can be performed by reading 1 from the TDRE flag in SSR, then clearing it to 0 and clearing the TEND flag to 0, or clearing the TEIE bit to 0.

Bits 1 and 0—Clock Enable 1 and 0 (CKE1, CKE0): These bits are used to select the SCI clock source and enable or disable clock output from the SCK pin. The combination of the CKE1 and CKE0 bits determines whether the SCK pin functions as an I/O port, the serial clock output pin, or the serial clock input pin.

The setting of the CKE0 bit, however, is only valid for internal clock operation (CKE1 = 0) in asynchronous mode. The CKE0 bit setting is invalid in clocked synchronous mode, and in the case of external clock operation (CKE1 = 1). Note that the SCI's operating mode must be decided using SMR before setting the CKE1 and CKE0 bits.

For details of clock source selection, see table 13.9 in section 13.3, Operation.

Bit 1	Bit 0	Description	
CKE1	CKE0		
0	0	Asynchronous mode	Internal clock/SCK pin functions as I/O port ^{*1}
		Clocked synchronous mode	Internal clock/SCK pin functions as serial clock output ^{*1}
	1	Asynchronous mode	Internal clock/SCK pin functions as clock output ^{*2}
		Clocked synchronous mode	Internal clock/SCK pin functions as serial clock output
1	0	Asynchronous mode	External clock/SCK pin functions as clock input ^{*3}
		Clocked synchronous mode	External clock/SCK pin functions as serial clock input
	1	Asynchronous mode	External clock/SCK pin functions as clock input ^{*3}
		Clocked synchronous mode	External clock/SCK pin functions as serial clock input

- Notes: 1. Initial value
 2. Outputs a clock of the same frequency as the bit rate.
 3. Inputs a clock with a frequency 16 times the bit rate.

13.2.7 Serial Status Register (SSR)

Bit	:	7	6	5	4	3	2	1	0
		TDRE	RDRF	ORER	FER	PER	TEND	MPB	MPBT
Initial value	:	1	0	0	0	0	1	0	0
R/W	:	R/(W)*	R/(W)*	R/(W)*	R/(W)*	R/(W)*	R	R	R/W

Note: * Only 0 can be written, to clear the flag.

SSR is an 8-bit register containing status flags that indicate the operating status of the SCI, and multiprocessor bits.

SSR can be read or written to by the CPU at all times. However, 1 cannot be written to flags TDRE, RDRF, ORER, PER, and FER. Also note that in order to clear these flags they must be read as 1 beforehand. The TEND flag and MPB flag are read-only flags and cannot be modified.

SSR is initialized to H'84 by a reset, in standby mode, watch mode*, subactive mode*, and subsleep mode* or module stop mode.

Note: * Subclock functions (subactive mode, subsleep mode, and watch mode) are available in the U-mask and W-mask versions, and H8S/2635 Group only.

These functions cannot be used with the other versions.

Bit 7—Transmit Data Register Empty (TDRE): Indicates that data has been transferred from TDR to TSR and the next serial data can be written to TDR.

Bit 7

TDRE	Description
0	[Clearing conditions] <ul style="list-style-type: none"> When 0 is written to TDRE after reading TDRE = 1 When the DTC is activated by a TXI interrupt and writes data to TDR
1	[Setting conditions] (Initial value) <ul style="list-style-type: none"> When the TE bit in SCR is 0 When data is transferred from TDR to TSR and data can be written to TDR

Bit 6—Receive Data Register Full (RDRF): Indicates that the received data is stored in RDR.

Bit 6

RDRF	Description	
0	[Clearing conditions] <ul style="list-style-type: none"> When 0 is written to RDRF after reading RDRF = 1 When the DTC is activated by an RXI interrupt and reads data from RDR 	(Initial value)
1	[Setting condition] <ul style="list-style-type: none"> When serial reception ends normally and receive data is transferred from RSR to RDR 	

Note: RDR and the RDRF flag are not affected and retain their previous values when an error is detected during reception or when the RE bit in SCR is cleared to 0.

If reception of the next data is completed while the RDRF flag is still set to 1, an overrun error will occur and the receive data will be lost.

Bit 5—Overrun Error (ORER): Indicates that an overrun error occurred during reception, causing abnormal termination.

Bit 5

ORER	Description	
0	[Clearing condition] <ul style="list-style-type: none"> When 0 is written to ORER after reading ORER = 1 	(Initial value) ^{*1}
1	[Setting condition] <ul style="list-style-type: none"> When the next serial reception is completed while RDRF = 1^{*2} 	

Notes: 1. The ORER flag is not affected and retains its previous state when the RE bit in SCR is cleared to 0.

2. The receive data prior to the overrun error is retained in RDR, and the data received subsequently is lost. Also, subsequent serial reception cannot be continued while the ORER flag is set to 1. In clocked synchronous mode, serial transmission cannot be continued, either.

Bit 4—Framing Error (FER): Indicates that a framing error occurred during reception in asynchronous mode, causing abnormal termination.

Bit 4

FER	Description
0	[Clearing condition] (Initial value)* ¹ <ul style="list-style-type: none"> When 0 is written to FER after reading FER = 1
1	[Setting condition] <ul style="list-style-type: none"> When the SCI checks whether the stop bit at the end of the receive data when reception ends, and the stop bit is 0*²

- Notes:
- The FER flag is not affected and retains its previous state when the RE bit in SCR is cleared to 0.
 - In 2-stop-bit mode, only the first stop bit is checked for a value of 0; the second stop bit is not checked. If a framing error occurs, the receive data is transferred to RDR but the RDRF flag is not set. Also, subsequent serial reception cannot be continued while the FER flag is set to 1. In clocked synchronous mode, serial transmission cannot be continued, either.

Bit 3—Parity Error (PER): Indicates that a parity error occurred during reception using parity addition in asynchronous mode, causing abnormal termination.

Bit 3

PER	Description
0	[Clearing condition] (Initial value)* ¹ <ul style="list-style-type: none"> When 0 is written to PER after reading PER = 1
1	[Setting condition] <ul style="list-style-type: none"> When, in reception, the number of 1 bits in the receive data plus the parity bit does not match the parity setting (even or odd) specified by the O/\bar{E} bit in SMR*²

- Notes:
- The PER flag is not affected and retains its previous state when the RE bit in SCR is cleared to 0.
 - If a parity error occurs, the receive data is transferred to RDR but the RDRF flag is not set. Also, subsequent serial reception cannot be continued while the PER flag is set to 1. In clocked synchronous mode, serial transmission cannot be continued, either.

Bit 2—Transmit End (TEND): Indicates that there is no valid data in TDR when the last bit of the transmit character is sent, and transmission has been ended.

The TEND flag is read-only and cannot be modified.

Bit 2

TEND	Description
0	[Clearing conditions] <ul style="list-style-type: none"> When 0 is written to TDRE after reading TDRE = 1 When the DMAC or DTC is activated by a TXI interrupt and writes data to TDR
1	[Setting conditions] (Initial value) <ul style="list-style-type: none"> When the TE bit in SCR is 0 When TDRE = 1 at transmission of the last bit of a 1-byte serial transmit character

Bit 1—Multiprocessor Bit (MPB): When reception is performed using multiprocessor format in asynchronous mode, MPB stores the multiprocessor bit in the receive data.

MPB is a read-only bit, and cannot be modified.

Bit 1

MPB	Description
0	[Clearing condition] (Initial value)* <ul style="list-style-type: none"> When data with a 0 multiprocessor bit is received
1	[Setting condition] <ul style="list-style-type: none"> When data with a 1 multiprocessor bit is received

Note: * Retains its previous state when the RE bit in SCR is cleared to 0 with multiprocessor format.

Bit 0—Multiprocessor Bit Transfer (MPBT): When transmission is performed using multiprocessor format in asynchronous mode, MPBT stores the multiprocessor bit to be added to the transmit data.

The MPBT bit setting is invalid when multiprocessor format is not used, when not transmitting, and in clocked synchronous mode.

Bit 0

MPBT	Description
0	Data with a 0 multiprocessor bit is transmitted (Initial value)
1	Data with a 1 multiprocessor bit is transmitted

13.2.8 Bit Rate Register (BRR)

Bit	:	7	6	5	4	3	2	1	0
		<input type="checkbox"/>	<input type="checkbox"/>	<input type="checkbox"/>	<input type="checkbox"/>	<input type="checkbox"/>	<input type="checkbox"/>	<input type="checkbox"/>	<input type="checkbox"/>
Initial value	:	1	1	1	1	1	1	1	1
R/W	:	R/W	R/W	R/W	R/W	R/W	R/W	R/W	R/W

BRR is an 8-bit register that sets the serial transfer bit rate in accordance with the baud rate generator operating clock selected by bits CKS1 and CKS0 in SMR.

BRR can be read or written to by the CPU at all times.

BRR is initialized to H'FF by a reset and in standby mode.

As baud rate generator control is performed independently for each channel, different values can be set for each channel.

Table 13-3 shows sample BRR settings in asynchronous mode, and table 13-4 shows sample BRR settings in clocked synchronous mode.

Table 13-3 BRR Settings for Various Bit Rates (Asynchronous Mode)

Bit Rate (bit/s)	$\phi = 4 \text{ MHz}$			$\phi = 4.9152 \text{ MHz}$			$\phi = 5 \text{ MHz}$		
	n	N	Error (%)	n	N	Error (%)	n	N	Error (%)
110	2	70	0.03	2	86	0.31	2	88	-0.25
150	1	207	0.16	1	255	0.00	2	64	0.16
300	1	103	0.16	1	127	0.00	1	129	0.16
600	0	207	0.16	0	255	0.00	1	64	0.16
1200	0	103	0.16	0	127	0.00	0	129	0.16
2400	0	51	0.16	0	63	0.00	0	64	0.16
4800	0	25	0.16	0	31	0.00	0	32	-1.36
9600	0	12	0.16	0	15	0.00	0	15	1.73
19200	—	—	—	0	7	0.00	0	7	1.73
31250	0	3	0.00	0	4	-1.70	0	4	0.00
38400	—	—	—	0	3	0.00	0	3	1.73

Bit Rate (bit/s)	$\phi = 6 \text{ MHz}$			$\phi = 6.144 \text{ MHz}$			$\phi = 7.3728 \text{ MHz}$			$\phi = 8 \text{ MHz}$		
	n	N	Error (%)	n	N	Error (%)	n	N	Error (%)	n	N	Error (%)
110	2	106	-0.44	2	108	0.08	2	130	-0.07	2	141	0.03
150	2	77	0.16	2	79	0.00	2	95	0.00	2	103	0.16
300	1	155	0.16	1	159	0.00	1	191	0.00	1	207	0.16
600	1	77	0.16	1	79	0.00	1	95	0.00	1	103	0.16
1200	0	155	0.16	0	159	0.00	0	191	0.00	0	207	0.16
2400	0	77	0.16	0	79	0.00	0	95	0.00	0	103	0.16
4800	0	38	0.16	0	39	0.00	0	47	0.00	0	51	0.16
9600	0	19	-2.34	0	19	0.00	0	23	0.00	0	25	0.16
19200	0	9	-2.34	0	9	0.00	0	11	0.00	0	12	0.16
31250	0	5	0.00	0	5	2.40	—	—	—	0	7	0.00
38400	0	4	-2.34	0	4	0.00	0	5	0.00	—	—	—

Bit Rate (bit/s)	$\phi = 9.8304 \text{ MHz}$			$\phi = 10 \text{ MHz}$			$\phi = 12 \text{ MHz}$			$\phi = 12.288 \text{ MHz}$		
	n	N	Error (%)	n	N	Error (%)	n	N	Error (%)	n	N	Error (%)
110	2	174	-0.26	2	177	-0.25	2	212	0.03	2	217	0.08
150	2	127	0.00	2	129	0.16	2	155	0.16	2	159	0.00
300	1	255	0.00	2	64	0.16	2	77	0.16	2	79	0.00
600	1	127	0.00	1	129	0.16	1	155	0.16	1	159	0.00
1200	0	255	0.00	1	64	0.16	1	77	0.16	1	79	0.00
2400	0	127	0.00	0	129	0.16	0	155	0.16	0	159	0.00
4800	0	63	0.00	0	64	0.16	0	77	0.16	0	79	0.00
9600	0	31	0.00	0	32	-1.36	0	38	0.16	0	39	0.00
19200	0	15	0.00	0	15	1.73	0	19	-2.34	0	19	0.00
31250	0	9	-1.70	0	9	0.00	0	11	0.00	0	11	2.40
38400	0	7	0.00	0	7	1.73	0	9	-2.34	0	9	0.00

Bit Rate (bit/s)	$\phi = 14$ MHz			$\phi = 14.7456$ MHz			$\phi = 16$ MHz			$\phi = 17.2032$ MHz		
	n	N	Error (%)	n	N	Error (%)	n	N	Error (%)	n	N	Error (%)
110	2	248	-0.17	3	64	0.70	3	70	0.03	3	75	0.48
150	2	181	0.16	2	191	0.00	2	207	0.16	2	223	0.00
300	2	90	0.16	2	95	0.00	2	103	0.16	2	111	0.00
600	1	181	0.16	1	191	0.00	1	207	0.16	1	223	0.00
1200	1	90	0.16	1	95	0.00	1	103	0.16	1	111	0.00
2400	0	181	0.16	0	191	0.00	0	207	0.16	0	223	0.00
4800	0	90	0.16	0	95	0.00	0	103	0.16	0	111	0.00
9600	0	45	-0.93	0	47	0.00	0	51	0.16	0	55	0.00
19200	0	22	-0.93	0	23	0.00	0	25	0.16	0	27	0.00
31250	0	13	0.00	0	14	-1.70	0	15	0.00	0	16	1.20
38400	—	—	—	0	11	0.00	0	12	0.16	0	13	0.00

Bit Rate (bit/s)	$\phi = 18$ MHz			$\phi = 19.6608$ MHz			$\phi = 20$ MHz		
	n	N	Error (%)	n	N	Error (%)	n	N	Error (%)
110	3	79	-0.12	3	86	0.31	3	88	-0.25
150	2	233	0.16	2	255	0.00	3	64	0.16
300	2	116	0.16	2	127	0.00	2	129	0.16
600	1	233	0.16	1	255	0.00	2	64	0.16
1200	1	116	0.16	1	127	0.00	1	129	0.16
2400	0	233	0.16	0	255	0.00	1	64	0.16
4800	0	116	0.16	0	127	0.00	0	129	0.16
9600	0	58	-0.69	0	63	0.00	0	64	0.16
19200	0	28	1.02	0	31	0.00	0	32	-1.36
31250	0	17	0.00	0	19	-1.70	0	19	0.00
38400	0	14	-2.34	0	15	0.00	0	15	1.73

Table 13-4 BRR Settings for Various Bit Rates (Clocked Synchronous Mode)

Bit Rate (bit/s)	$\phi = 4$ MHz		$\phi = 8$ MHz		$\phi = 10$ MHz		$\phi = 16$ MHz		$\phi = 20$ MHz	
	n	N	n	N	n	N	n	N	n	N
110	—	—								
250	2	249	3	124	—	—	3	249		
500	2	124	2	249	—	—	3	124	—	—
1 k	1	249	2	124	—	—	2	249	—	—
2.5 k	1	99	1	199	1	249	2	99	2	124
5 k	0	199	1	99	1	124	1	199	1	249
10 k	0	99	0	199	0	249	1	99	1	124
25 k	0	39	0	79	0	99	0	159	0	199
50 k	0	19	0	39	0	49	0	79	0	99
100 k	0	9	0	19	0	24	0	39	0	49
250 k	0	3	0	7	0	9	0	15	0	19
500 k	0	1	0	3	0	4	0	7	0	9
1 M	0	0*	0	1			0	3	0	4
2.5 M					0	0*			0	1
5 M									0	0*

Note: As far as possible, the setting should be made so that the error is no more than 1%.

Legend:

Blank: Cannot be set.

—: Can be set, but there will be a degree of error.

*: Continuous transfer is not possible.

The BRR setting is found from the following formulas.

Asynchronous mode:

$$N = \frac{\phi}{64 \times 2^{2n-1} \times B} \times 10^6 - 1$$

Clocked synchronous mode:

$$N = \frac{\phi}{8 \times 2^{2n-1} \times B} \times 10^6 - 1$$

Where B: Bit rate (bit/s)

N: BRR setting for baud rate generator ($0 \leq N \leq 255$)

ϕ : Operating frequency (MHz)

n: Baud rate generator input clock ($n = 0$ to 3)

(See the table below for the relation between n and the clock.)

n	Clock	SMR Setting	
		CKS1	CKS0
0	ϕ	0	0
1	$\phi/4$	0	1
2	$\phi/16$	1	0
3	$\phi/64$	1	1

The bit rate error in asynchronous mode is found from the following formula:

$$\text{Error (\%)} = \left\{ \frac{\phi \times 10^6}{(N + 1) \times B \times 64 \times 2^{2n-1}} - 1 \right\} \times 100$$

Table 13-5 shows the maximum bit rate for each frequency in asynchronous mode. Tables 13-6 and 13-7 show the maximum bit rates with external clock input.

Table 13-5 Maximum Bit Rate for Each Frequency (Asynchronous Mode)

ϕ (MHz)	Maximum Bit Rate (bit/s)	n	N
4	125000	0	0
4.9152	153600	0	0
5	156250	0	0
6	187500	0	0
6.144	192000	0	0
7.3728	230400	0	0
8	250000	0	0
9.8304	307200	0	0
10	312500	0	0
12	375000	0	0
12.288	384000	0	0
14	437500	0	0
14.7456	460800	0	0
16	500000	0	0
17.2032	537600	0	0
18	562500	0	0
19.6608	614400	0	0
20	625000	0	0

Table 13-6 Maximum Bit Rate with External Clock Input (Asynchronous Mode)

ϕ (MHz)	External Input Clock (MHz)	Maximum Bit Rate (bit/s)
4	1.0000	62500
4.9152	1.2288	76800
5	1.2500	78125
6	1.5000	93750
6.144	1.5360	96000
7.3728	1.8432	115200
8	2.0000	125000
9.8304	2.4576	153600
10	2.5000	156250
12	3.0000	187500
12.288	3.0720	192000
14	3.5000	218750
14.7456	3.6864	230400
16	4.0000	250000
17.2032	4.3008	268800
18	4.5000	281250
19.6608	4.9152	307200
20	5.0000	312500

Table 13-7 Maximum Bit Rate with External Clock Input (Clocked Synchronous Mode)

ϕ (MHz)	External Input Clock (MHz)	Maximum Bit Rate (bit/s)
4	0.6667	666666.7
6	1.0000	1000000.0
8	1.3333	1333333.3
10	1.6667	1666666.7
12	2.0000	2000000.0
14	2.3333	2333333.3
16	2.6667	2666666.7
18	3.0000	3000000.0
20	3.3333	3333333.3

13.2.9 Smart Card Mode Register (SCMR)

Bit	:	7	6	5	4	3	2	1	0
		—	—	—	—	SDIR	SINV	—	SMIF
Initial value	:	1	1	1	1	0	0	1	0
R/W	:	—	—	—	—	R/W	R/W	—	R/W

SCMR selects LSB-first or MSB-first by means of bit SDIR. Except in the case of asynchronous mode 7-bit data, LSB-first or MSB-first can be selected regardless of the serial communication mode. The descriptions in this chapter refer to LSB-first transfer.

For details of the other bits in SCMR, see section 14.2.1, Smart Card Mode Register (SCMR).

SCMR is initialized to HF2 by a reset and in standby mode.

Bits 7 to 4—Reserved: These bits are always read as 1 and cannot be modified.

Bit 3—Smart Card Data Transfer Direction (SDIR): Selects the serial/parallel conversion format.

This bit is valid when 8-bit data is used as the transmit/receive format.

Bit 3

SDIR	Description
0	TDR contents are transmitted LSB-first Receive data is stored in RDR LSB-first (Initial value)
1	TDR contents are transmitted MSB-first Receive data is stored in RDR MSB-first

Bit 2—Smart Card Data Invert (SINV): Specifies inversion of the data logic level. The SINV bit does not affect the logic level of the parity bit(s): parity bit inversion requires inversion of the O/E bit in SMR.

Bit 2

SINV	Description	
0	TDR contents are transmitted without modification Receive data is stored in RDR without modification	(Initial value)
1	TDR contents are inverted before being transmitted Receive data is stored in RDR in inverted form	

Bit 1—Reserved: This bit is always read as 1 and cannot be modified.

Bit 0—Smart Card Interface Mode Select (SMIF): When the smart card interface operates as a normal SCI, 0 should be written in this bit.

Bit 0

SMIF	Description	
0	Operates as normal SCI (smart card interface function disabled)	(Initial value)
1	Smart card interface function enabled	

13.2.10 Module Stop Control Register B (MSTPCRB)

MSTPCRB

Bit	:	7	6	5	4	3	2	1	0
		MSTPB7	MSTPB6	MSTPB5	MSTPB4	MSTPB3	MSTPB2	MSTPB1	MSTPB0
Initial value	:	1	1	1	1	1	1	1	1
R/W	:	R/W	R/W	R/W	R/W	R/W	R/W	R/W	R/W

MSTPCRB is 8-bit readable/writable registers that perform module stop mode control.

Setting any of bits MSTPB7 to MSTPB5 to 1 stops SCI0 to SCI2 operating and enter module stop mode on completion of the bus cycle. For details, see section 23A.5, 23B.5, Module Stop Mode.

MSTPCRB is initialized to H'FF by a reset and in hardware standby mode. They are not initialized by a manual reset and in software standby mode.

Bit 7—Module Stop (MSTPB7): Specifies the SCI0 module stop mode.

Bit 7

MSTPB7	Description
0	SCI0 module stop mode is cleared
1	SCI0 module stop mode is set (Initial value)

Bit 6—Module Stop (MSTPB6): Specifies the SCI1 module stop mode.

Bit 6

MSTPB6	Description
0	SCI1 module stop mode is cleared
1	SCI1 module stop mode is set (Initial value)

Bit 5—Module Stop (MSTPB5): Specifies the SCI2 module stop mode.

Bit 5

MSTPB5	Description
0	SCI2 module stop mode is cleared
1	SCI2 module stop mode is set (Initial value)

13.3 Operation

13.3.1 Overview

The SCI can carry out serial communication in two modes: asynchronous mode in which synchronization is achieved character by character, and clocked synchronous mode in which synchronization is achieved with clock pulses.

Selection of asynchronous or clocked synchronous mode and the transmission format is made using SMR as shown in table 13-8. The SCI clock is determined by a combination of the C/\bar{A} bit in SMR and the CKE1 and CKE0 bits in SCR, as shown in table 13-9.

Asynchronous Mode

- Data length: Choice of 7 or 8 bits
- Choice of parity addition, multiprocessor bit addition, and addition of 1 or 2 stop bits (the combination of these parameters determines the transfer format and character length)
- Detection of framing, parity, and overrun errors, and breaks, during reception
- Choice of internal or external clock as SCI clock source
 - When internal clock is selected:

The SCI operates on the baud rate generator clock and a clock with the same frequency as the bit rate can be output
 - When external clock is selected:

A clock with a frequency of 16 times the bit rate must be input (the on-chip baud rate generator is not used)

Clocked Synchronous Mode

- Transfer format: Fixed 8-bit data
- Detection of overrun errors during reception
- Choice of internal or external clock as SCI clock source
 - When internal clock is selected:

The SCI operates on the baud rate generator clock and a serial clock is output off-chip
 - When external clock is selected:

The on-chip baud rate generator is not used, and the SCI operates on the input serial clock

Table 13-8 SMR Settings and Serial Transfer Format Selection

SMR Settings					SCI Transfer Format				
Bit 7	Bit 6	Bit 2	Bit 5	Bit 3	Mode	Data Length	Multi Processor Bit	Parity Bit	Stop Bit Length
C/ \bar{A}	CHR	MP	PE	STOP					
0	0	0	0	0	Asynchronous mode	8-bit data	No	No	1 bit
				1					2 bits
				0					1 bit
				1					2 bits
				0					1 bit
				1					2 bits
	1	0	0	0	Asynchronous mode (multi-processor format)	7-bit data	Yes	No	1 bit
				1					2 bits
				0					1 bit
				1					2 bits
0	1	—	0	Asynchronous mode (multi-processor format)	8-bit data	Yes	No	1 bit	
			1					2 bits	
1	—	—	0	Asynchronous mode (multi-processor format)	7-bit data	No	Yes	1 bit	
			1					2 bits	
1	—	—	—	—	Clocked synchronous mode	8-bit data	No	None	

Table 13-9 SMR and SCR Settings and SCI Clock Source Selection

SMR	SCR Setting			SCI Transmit/Receive Clock	
Bit 7	Bit 1	Bit 0	Mode	Clock Source	SCK Pin Function
C/ \bar{A}	CKE1	CKE0			
0	0	0	Asynchronous mode	Internal	SCI does not use SCK pin
		1			Outputs clock with same frequency as bit rate
1	1	0	Asynchronous mode	External	Inputs clock with frequency of 16 times the bit rate
		1			Outputs serial clock
1	0	0	Clocked synchronous mode	Internal	Outputs serial clock
		1			Inputs serial clock
1	1	0	Clocked synchronous mode	External	Inputs serial clock
		1			Outputs serial clock

13.3.2 Operation in Asynchronous Mode

In asynchronous mode, characters are sent or received, each preceded by a start bit indicating the start of communication and stop bits indicating the end of communication. Serial communication is thus carried out with synchronization established on a character-by-character basis.

Inside the SCI, the transmitter and receiver are independent units, enabling full-duplex communication. Both the transmitter and the receiver also have a double-buffered structure, so that data can be read or written during transmission or reception, enabling continuous data transfer.

Figure 13-2 shows the general format for asynchronous serial communication.

In asynchronous serial communication, the transmission line is usually held in the mark state (high level). The SCI monitors the transmission line, and when it goes to the space state (low level), recognizes a start bit and starts serial communication.

One serial communication character consists of a start bit (low level), followed by data (in LSB-first order), a parity bit (high or low level), and finally stop bits (high level).

In asynchronous mode, the SCI performs synchronization at the falling edge of the start bit in reception. The SCI samples the data on the 8th pulse of a clock with a frequency of 16 times the length of one bit, so that the transfer data is latched at the center of each bit.

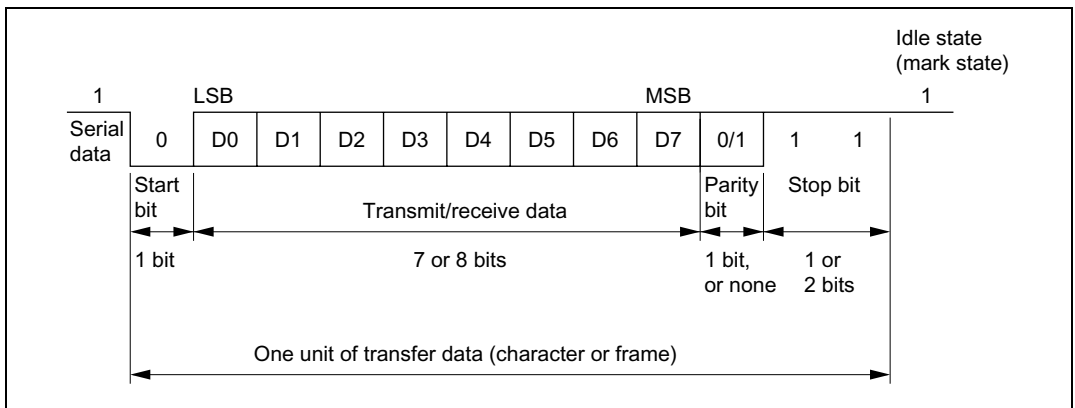

**Figure 13-2 Data Format in Asynchronous Communication
(Example with 8-Bit Data, Parity, Two Stop Bits)**

Data Transfer Format: Table 13-10 shows the data transfer formats that can be used in asynchronous mode. Any of 12 transfer formats can be selected according to the SMR setting.

Table 13-10 Serial Transfer Formats (Asynchronous Mode)

SMR Settings				Serial Transfer Format and Frame Length													
CHR	PE	MP	STOP	1	2	3	4	5	6	7	8	9	10	11	12		
0	0	0	0	S	8-bit data								STOP				
0	0	0	1	S	8-bit data								STOP	STOP			
0	1	0	0	S	8-bit data								P	STOP			
0	1	0	1	S	8-bit data								P	STOP	STOP		
1	0	0	0	S	7-bit data							STOP					
1	0	0	1	S	7-bit data							STOP	STOP				
1	1	0	0	S	7-bit data							P	STOP				
1	1	0	1	S	7-bit data							P	STOP	STOP			
0	—	1	0	S	8-bit data								MPB	STOP			
0	—	1	1	S	8-bit data								MPB	STOP	STOP		
1	—	1	0	S	7-bit data							MPB	STOP				
1	—	1	1	S	7-bit data							MPB	STOP	STOP			

Legend:

S: Start bit

STOP: Stop bit

P: Parity bit

MPB: Multiprocessor bit

Clock: Either an internal clock generated by the on-chip baud rate generator or an external clock input at the SCK pin can be selected as the SCI's serial clock, according to the setting of the C/\overline{A} bit in SMR and the CKE1 and CKE0 bits in SCR. For details of SCI clock source selection, see table 13-9.

When an external clock is input at the SCK pin, the clock frequency should be 16 times the bit rate used.

When the SCI is operated on an internal clock, the clock can be output from the SCK pin. The frequency of the clock output in this case is equal to the bit rate, and the phase is such that the rising edge of the clock is in the middle of the transmit data, as shown in figure 13-3.

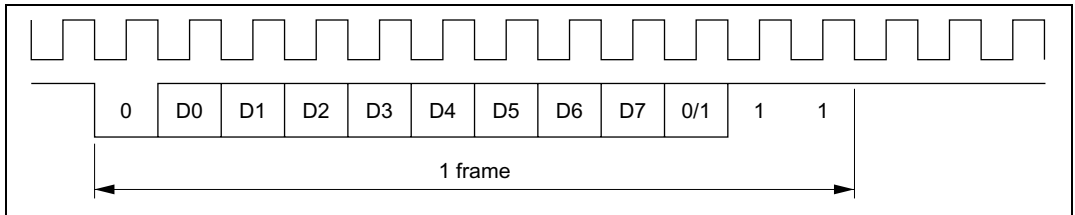

**Figure 13-3 Relation between Output Clock and Transfer Data Phase
(Asynchronous Mode)**

Data Transfer Operations:

- SCI initialization (asynchronous mode)

Before transmitting and receiving data, you should first clear the TE and RE bits in SCR to 0, then initialize the SCI as described below.

When the operating mode, transfer format, etc., is changed, the TE and RE bits must be cleared to 0 before making the change using the following procedure. When the TE bit is cleared to 0, the TDRE flag is set to 1 and TSR is initialized. Note that clearing the RE bit to 0 does not change the contents of the RDRF, PER, FER, and ORER flags, or the contents of RDR.

When an external clock is used the clock should not be stopped during operation, including initialization, since operation is uncertain.

Figure 13-4 shows a sample SCI initialization flowchart.

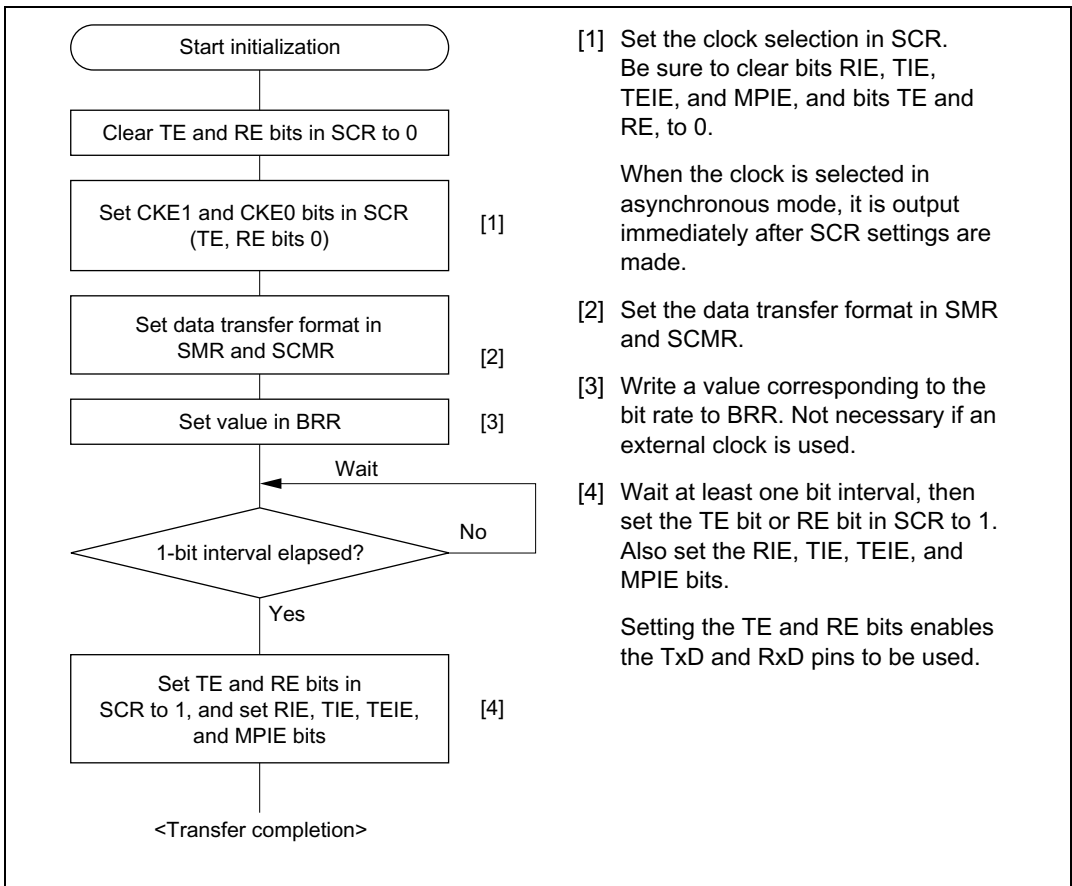

Figure 13-4 Sample SCI Initialization Flowchart

- Serial data transmission (asynchronous mode)

Figure 13-5 shows a sample flowchart for serial transmission.

The following procedure should be used for serial data transmission.

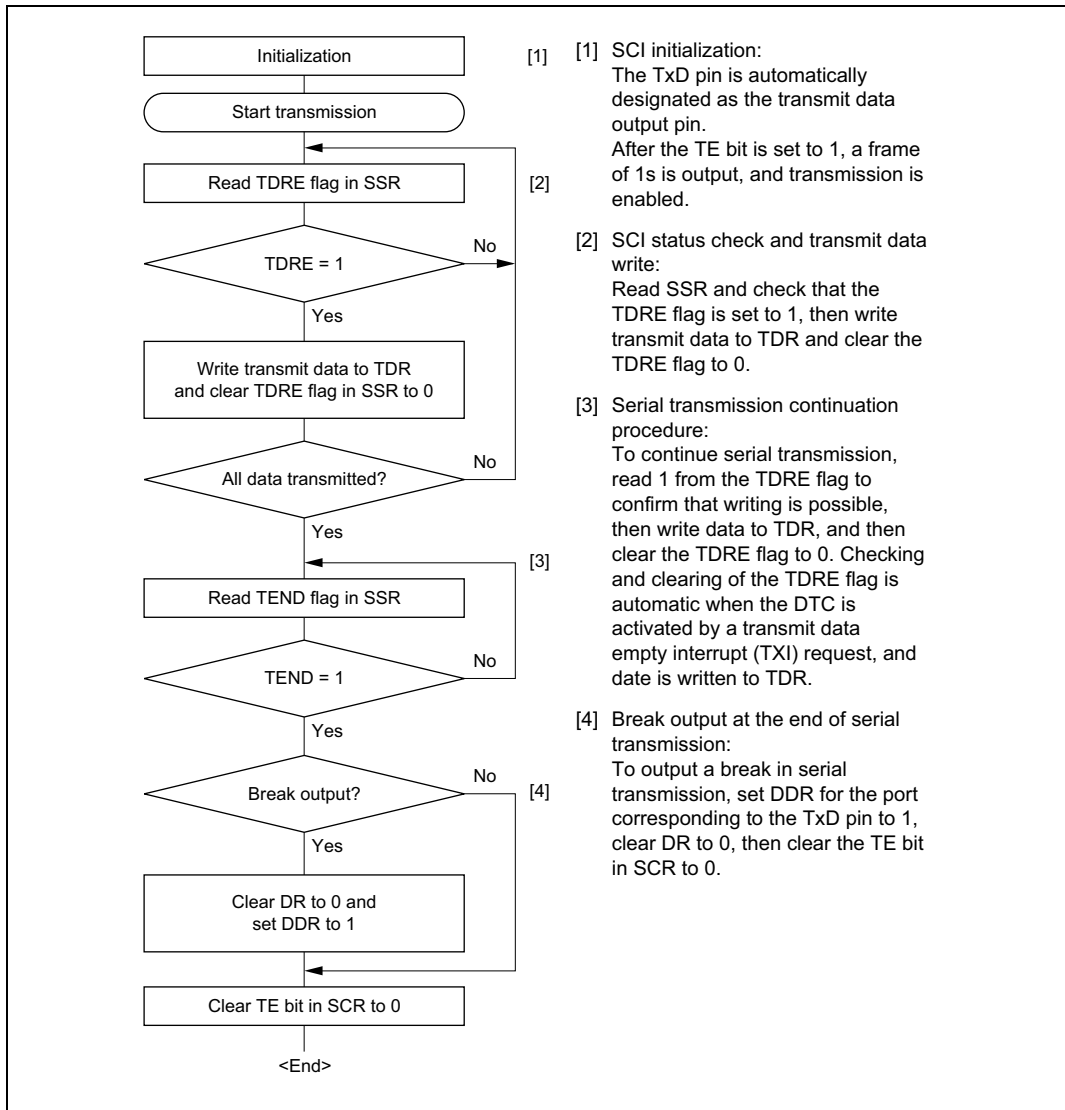

Figure 13-5 Sample Serial Transmission Flowchart

In serial transmission, the SCI operates as described below.

[1] The SCI monitors the TDRE flag in SSR, and if it is 0, recognizes that data has been written to TDR, and transfers the data from TDR to TSR.

[2] After transferring data from TDR to TSR, the SCI sets the TDRE flag to 1 and starts transmission.

If the TIE bit is set to 1 at this time, a transmit data empty interrupt (TXI) is generated. The serial transmit data is sent from the TxD pin in the following order.

[a] Start bit:

One 0-bit is output.

[b] Transmit data:

8-bit or 7-bit data is output in LSB-first order.

[c] Parity bit or multiprocessor bit:

One parity bit (even or odd parity), or one multiprocessor bit is output.

A format in which neither a parity bit nor a multiprocessor bit is output can also be selected.

[d] Stop bit(s):

One or two 1-bits (stop bits) are output.

[e] Mark state:

1 is output continuously until the start bit that starts the next transmission is sent.

[3] The SCI checks the TDRE flag at the timing for sending the stop bit.

If the TDRE flag is cleared to 0, the data is transferred from TDR to TSR, the stop bit is sent, and then serial transmission of the next frame is started.

If the TDRE flag is set to 1, the TEND flag in SSR is set to 1, the stop bit is sent, and then the "mark state" is entered in which 1 is output continuously. If the TEIE bit in SCR is set to 1 at this time, a TEI interrupt request is generated.

Figure 13-6 shows an example of the operation for transmission in asynchronous mode.

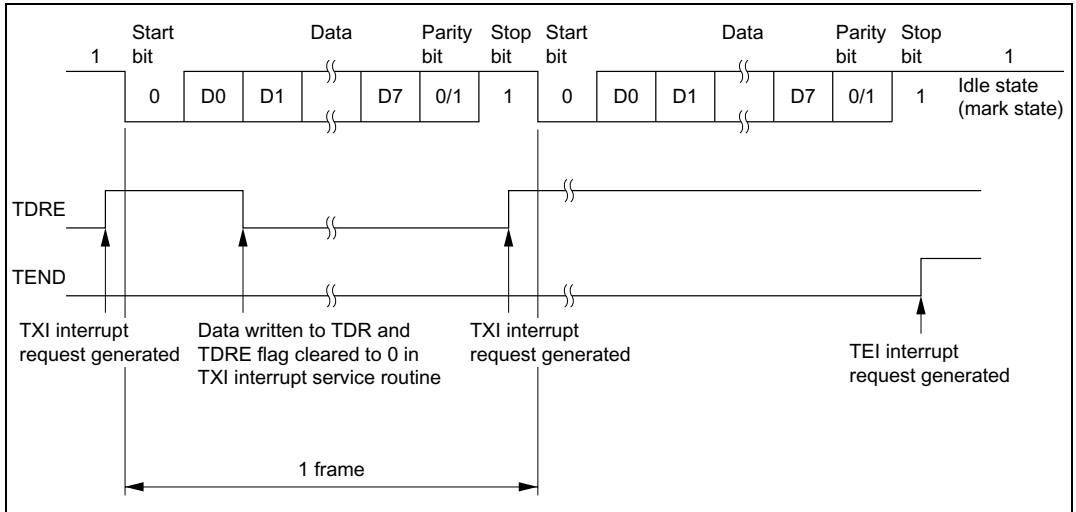

**Figure 13-6 Example of Operation in Transmission in Asynchronous Mode
(Example with 8-Bit Data, Parity, One Stop Bit)**

- Serial data reception (asynchronous mode)

Figure 13-7 shows a sample flowchart for serial reception.

The following procedure should be used for serial data reception.

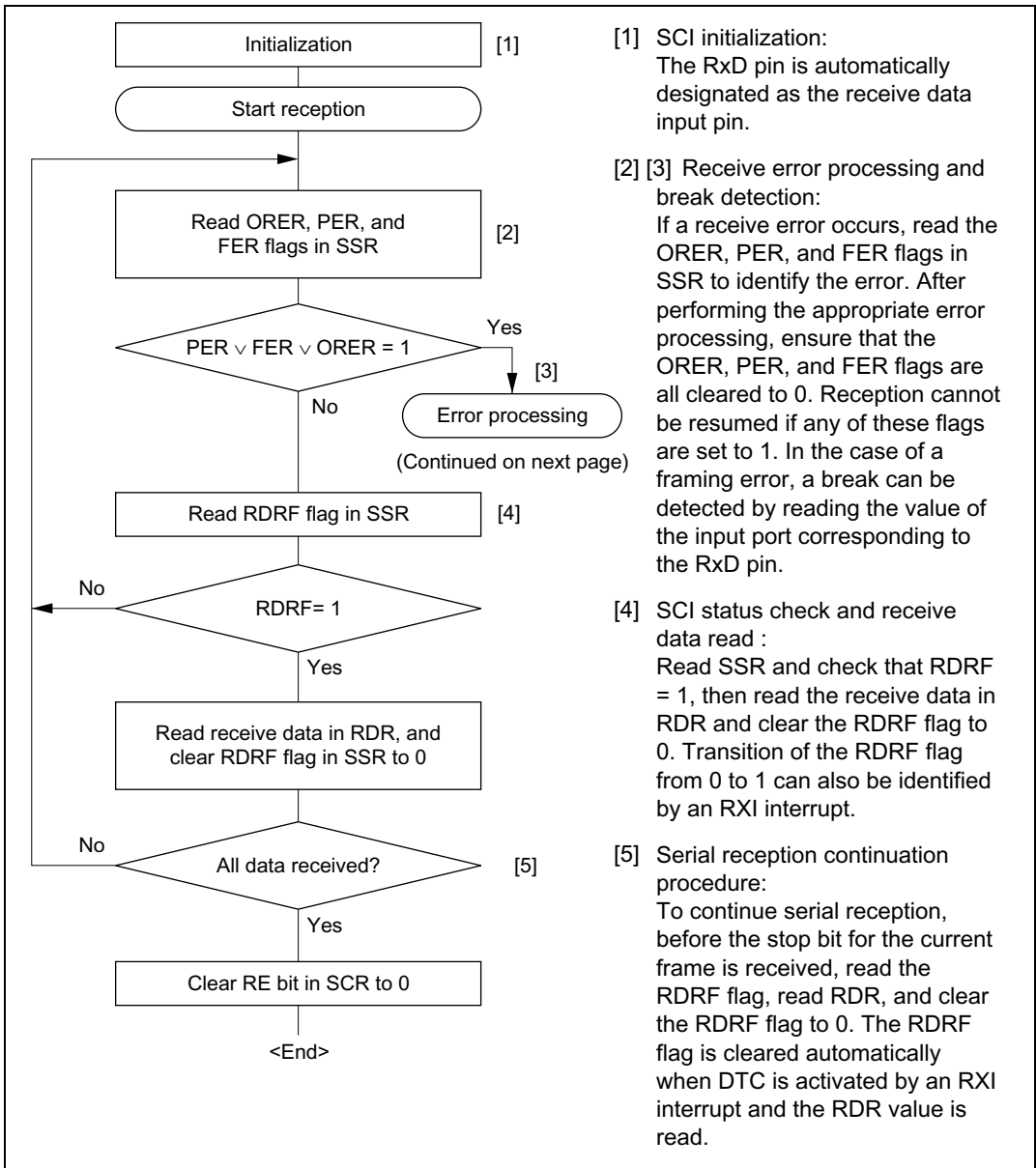

Figure 13-7 Sample Serial Reception Data Flowchart

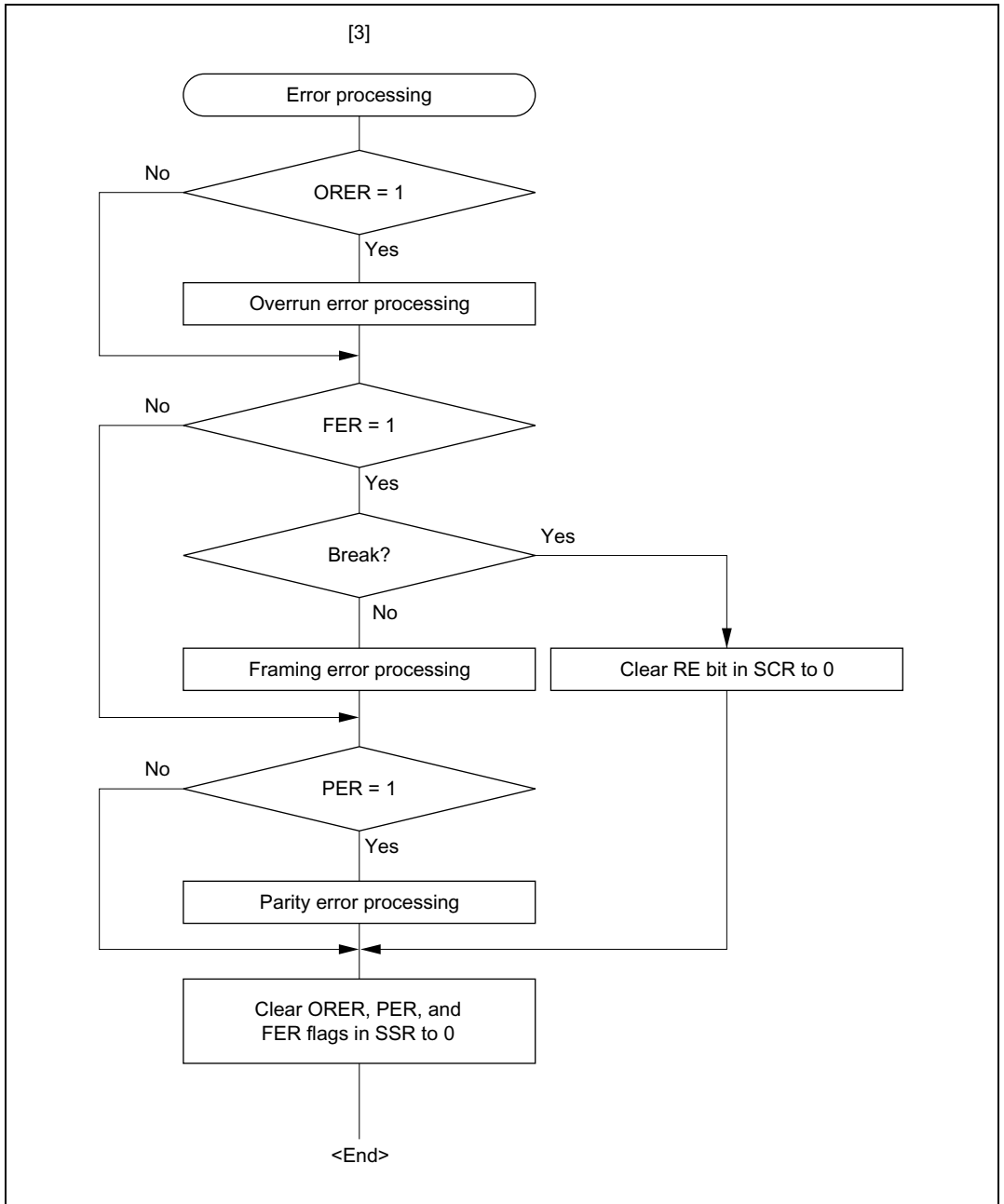

Figure 13-7 Sample Serial Reception Data Flowchart (cont)

In serial reception, the SCI operates as described below.

[1] The SCI monitors the transmission line, and if a 0 stop bit is detected, performs internal synchronization and starts reception.

[2] The received data is stored in RSR in LSB-to-MSB order.

[3] The parity bit and stop bit are received.

After receiving these bits, the SCI carries out the following checks.

[a] Parity check:

The SCI checks whether the number of 1 bits in the receive data agrees with the parity (even or odd) set in the O/\bar{E} bit in SMR.

[b] Stop bit check:

The SCI checks whether the stop bit is 1.

If there are two stop bits, only the first is checked.

[c] Status check:

The SCI checks whether the RDRF flag is 0, indicating that the receive data can be transferred from RSR to RDR.

If all the above checks are passed, the RDRF flag is set to 1, and the receive data is stored in RDR.

If a receive error* is detected in the error check, the operation is as shown in table 13-11.

Note: * Subsequent receive operations cannot be performed when a receive error has occurred.

Also note that the RDRF flag is not set to 1 in reception, and so the error flags must be cleared to 0.

[4] If the RIE bit in SCR is set to 1 when the RDRF flag changes to 1, a receive data full interrupt (RXI) request is generated.

Also, if the RIE bit in SCR is set to 1 when the ORER, PER, or FER flag changes to 1, a receive error interrupt (ERI) request is generated.

Table 13-11 Receive Errors and Conditions for Occurrence

Receive Error	Abbreviation	Occurrence Condition	Data Transfer
Overrun error	ORER	When the next data reception is completed while the RDRF flag in SSR is set to 1	Receive data is not transferred from RSR to RDR
Framing error	FER	When the stop bit is 0	Receive data is transferred from RSR to RDR
Parity error	PER	When the received data differs from the parity (even or odd) set in SMR	Receive data is transferred from RSR to RDR

Figure 13-8 shows an example of the operation for reception in asynchronous mode.

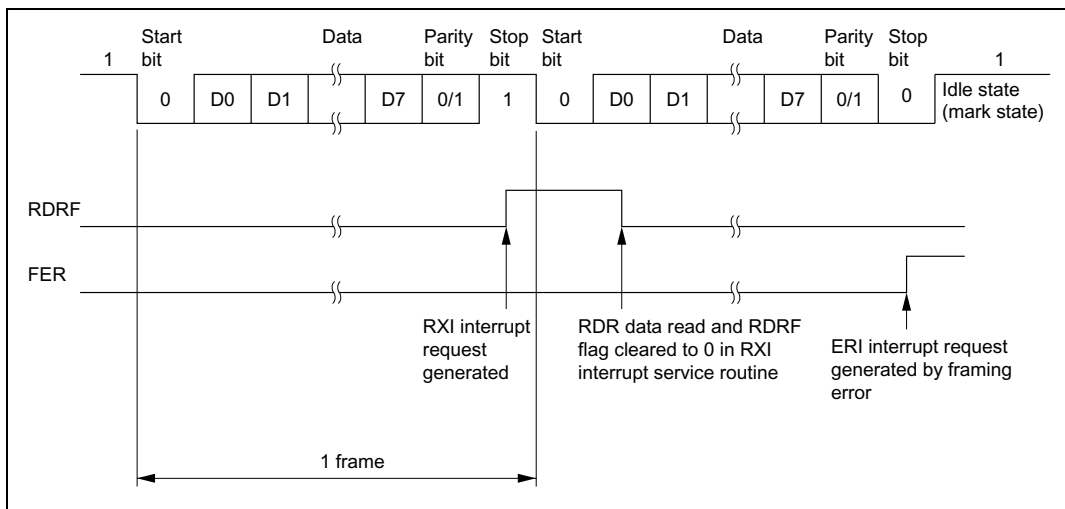

**Figure 13-8 Example of SCI Operation in Reception
(Example with 8-Bit Data, Parity, One Stop Bit)**

13.3.3 Multiprocessor Communication Function

The multiprocessor communication function performs serial communication using the multiprocessor format, in which a multiprocessor bit is added to the transfer data, in asynchronous mode. Use of this function enables data transfer to be performed among a number of processors sharing transmission lines.

When multiprocessor communication is carried out, each receiving station is addressed by a unique ID code.

The serial communication cycle consists of two component cycles: an ID transmission cycle which specifies the receiving station, and a data transmission cycle. The multiprocessor bit is used to differentiate between the ID transmission cycle and the data transmission cycle.

The transmitting station first sends the ID of the receiving station with which it wants to perform serial communication as data with a 1 multiprocessor bit added. It then sends transmit data as data with a 0 multiprocessor bit added.

The receiving station skips the data until data with a 1 multiprocessor bit is sent.

When data with a 1 multiprocessor bit is received, the receiving station compares that data with its own ID. The station whose ID matches then receives the data sent next. Stations whose ID does not match continue to skip the data until data with a 1 multiprocessor bit is again received. In this way, data communication is carried out among a number of processors.

Figure 13-9 shows an example of inter-processor communication using the multiprocessor format.

Data Transfer Format: There are four data transfer formats.

When the multiprocessor format is specified, the parity bit specification is invalid.

For details, see table 13-10.

Clock: See the section on asynchronous mode.

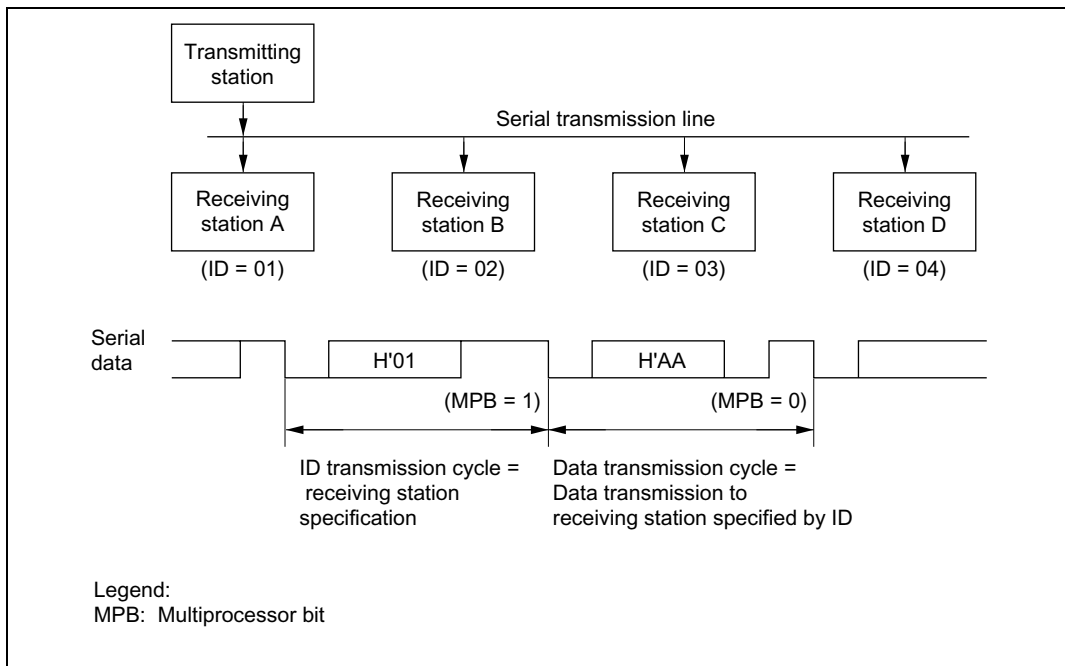

**Figure 13-9 Example of Inter-Processor Communication Using Multiprocessor Format
(Transmission of Data H'AA to Receiving Station A)**

Data Transfer Operations:

- Multiprocessor serial data transmission

Figure 13-10 shows a sample flowchart for multiprocessor serial data transmission.

The following procedure should be used for multiprocessor serial data transmission.

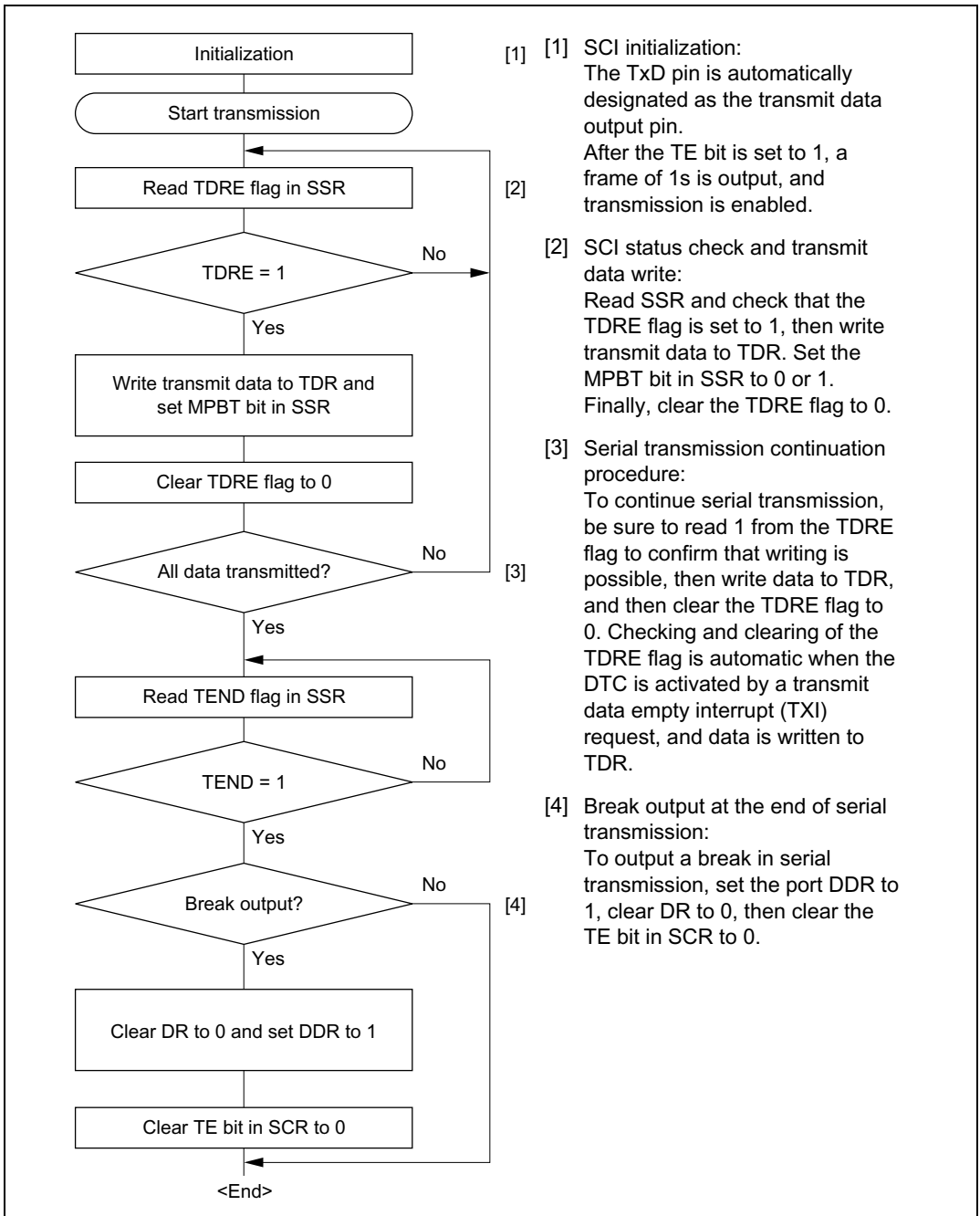

Figure 13-10 Sample Multiprocessor Serial Transmission Flowchart

In serial transmission, the SCI operates as described below.

[1] The SCI monitors the TDRE flag in SSR, and if it is 0, recognizes that data has been written to TDR, and transfers the data from TDR to TSR.

[2] After transferring data from TDR to TSR, the SCI sets the TDRE flag to 1 and starts transmission.

If the TIE bit in SCR is set to 1 at this time, a transmit data empty interrupt (TXI) is generated. The serial transmit data is sent from the TxD pin in the following order.

[a] Start bit:

One 0-bit is output.

[b] Transmit data:

8-bit or 7-bit data is output in LSB-first order.

[c] Multiprocessor bit

One multiprocessor bit (MPBT value) is output.

[d] Stop bit(s):

One or two 1-bits (stop bits) are output.

[e] Mark state:

1 is output continuously until the start bit that starts the next transmission is sent.

[3] The SCI checks the TDRE flag at the timing for sending the stop bit.

If the TDRE flag is cleared to 0, data is transferred from TDR to TSR, the stop bit is sent, and then serial transmission of the next frame is started.

If the TDRE flag is set to 1, the TEND flag in SSR is set to 1, the stop bit is sent, and then the mark state is entered in which 1 is output continuously. If the TEIE bit in SCR is set to 1 at this time, a transmission end interrupt (TEI) request is generated.

Figure 13-11 shows an example of SCI operation for transmission using the multiprocessor format.

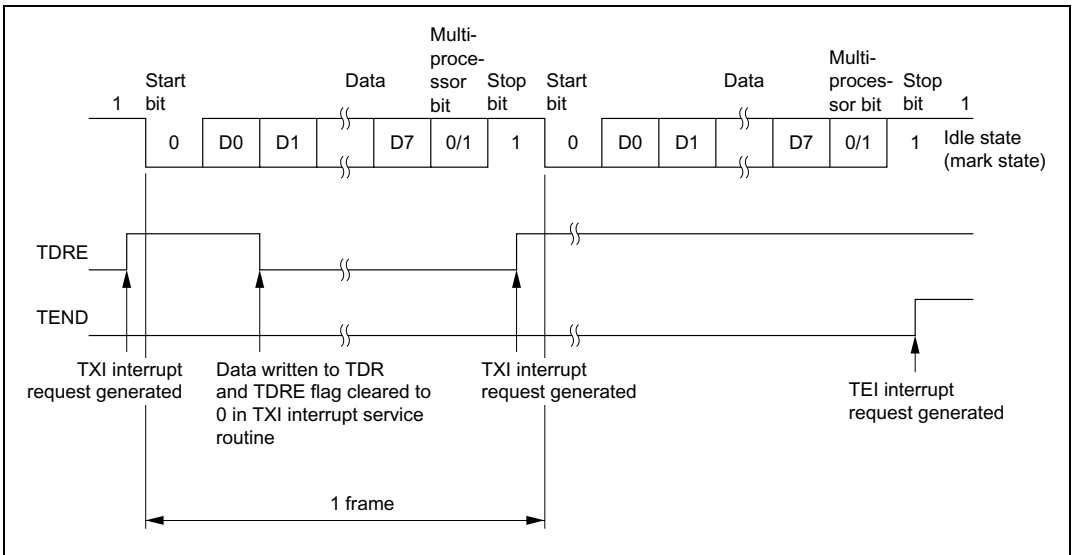

**Figure 13-11 Example of SCI Operation in Transmission
(Example with 8-Bit Data, Multiprocessor Bit, One Stop Bit)**

- Multiprocessor serial data reception

Figure 13-12 shows a sample flowchart for multiprocessor serial reception.

The following procedure should be used for multiprocessor serial data reception.

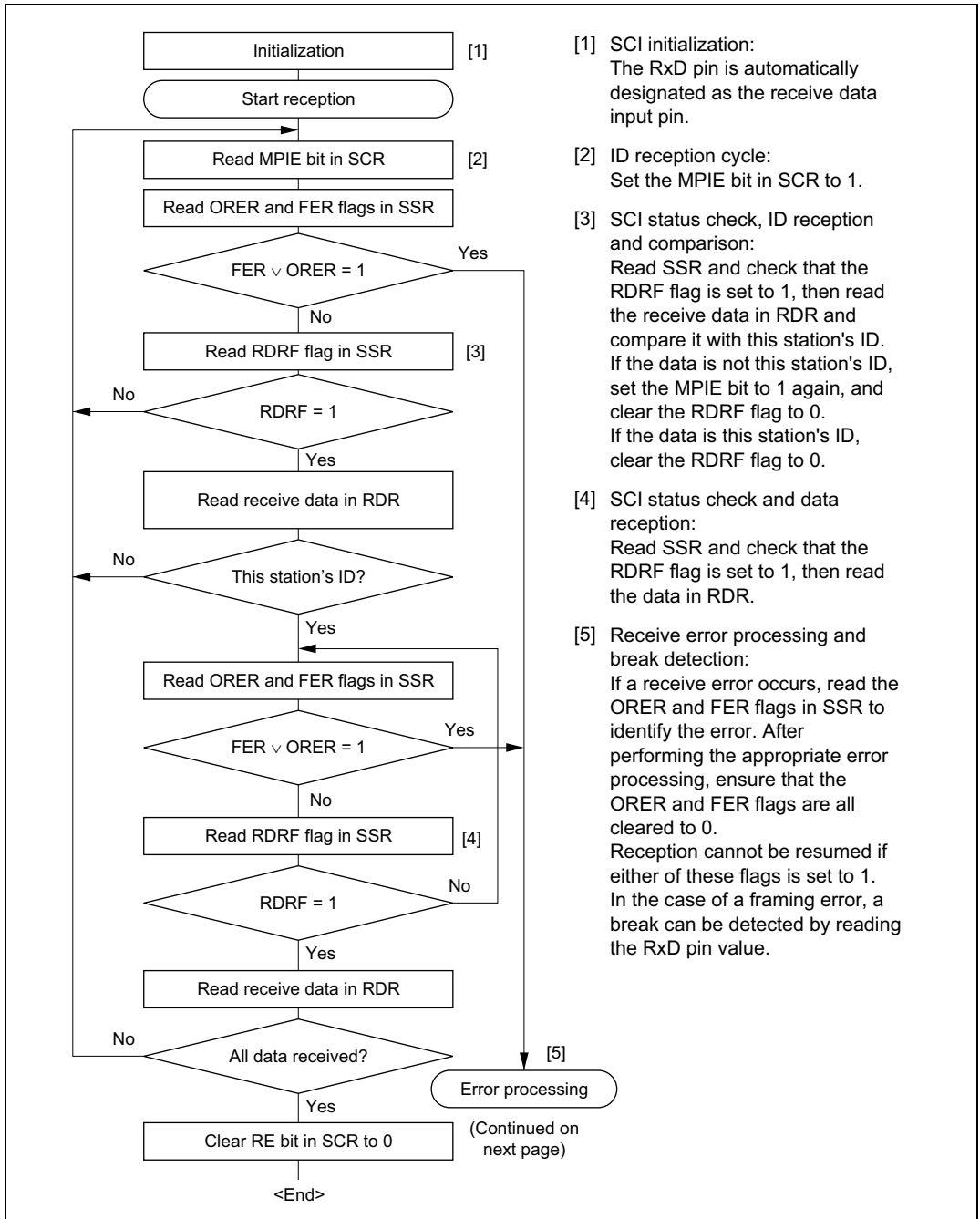

Figure 13-12 Sample Multiprocessor Serial Reception Flowchart

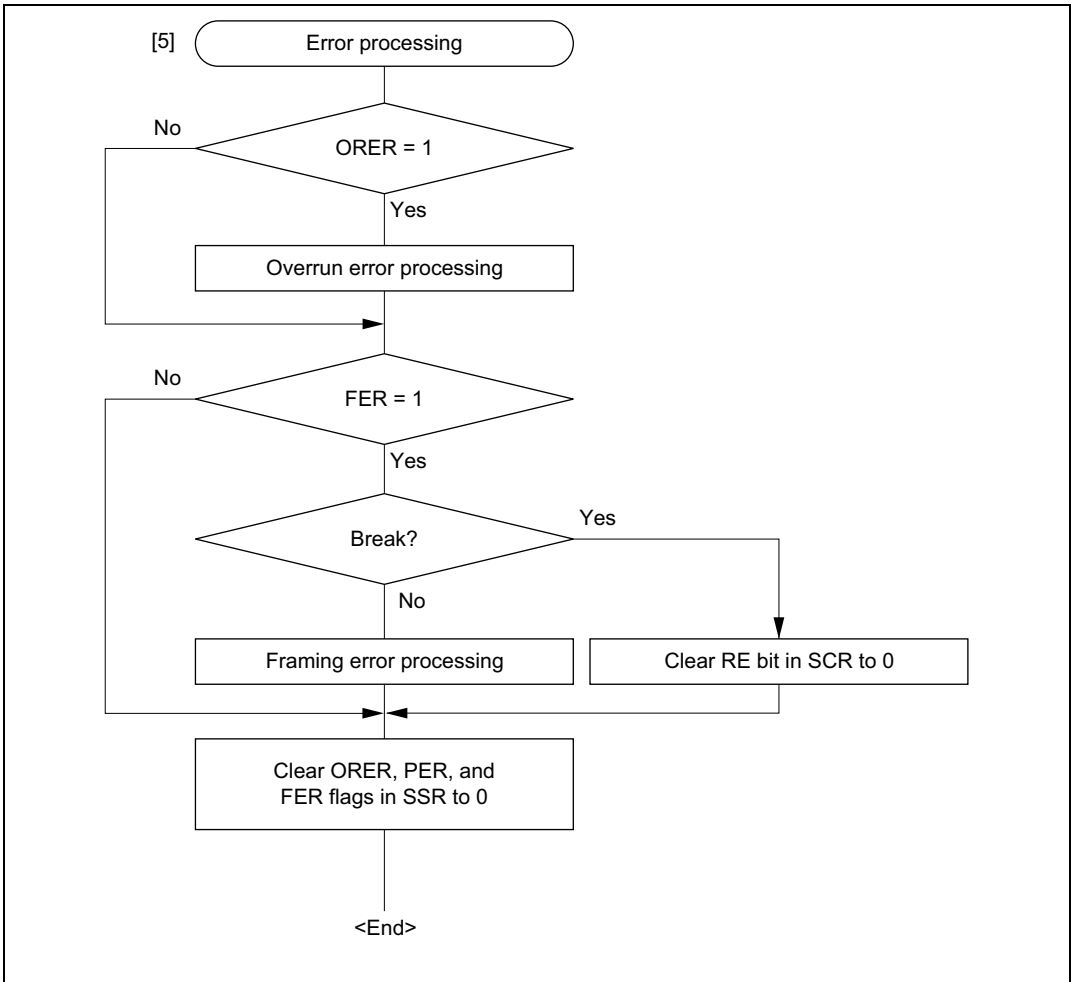
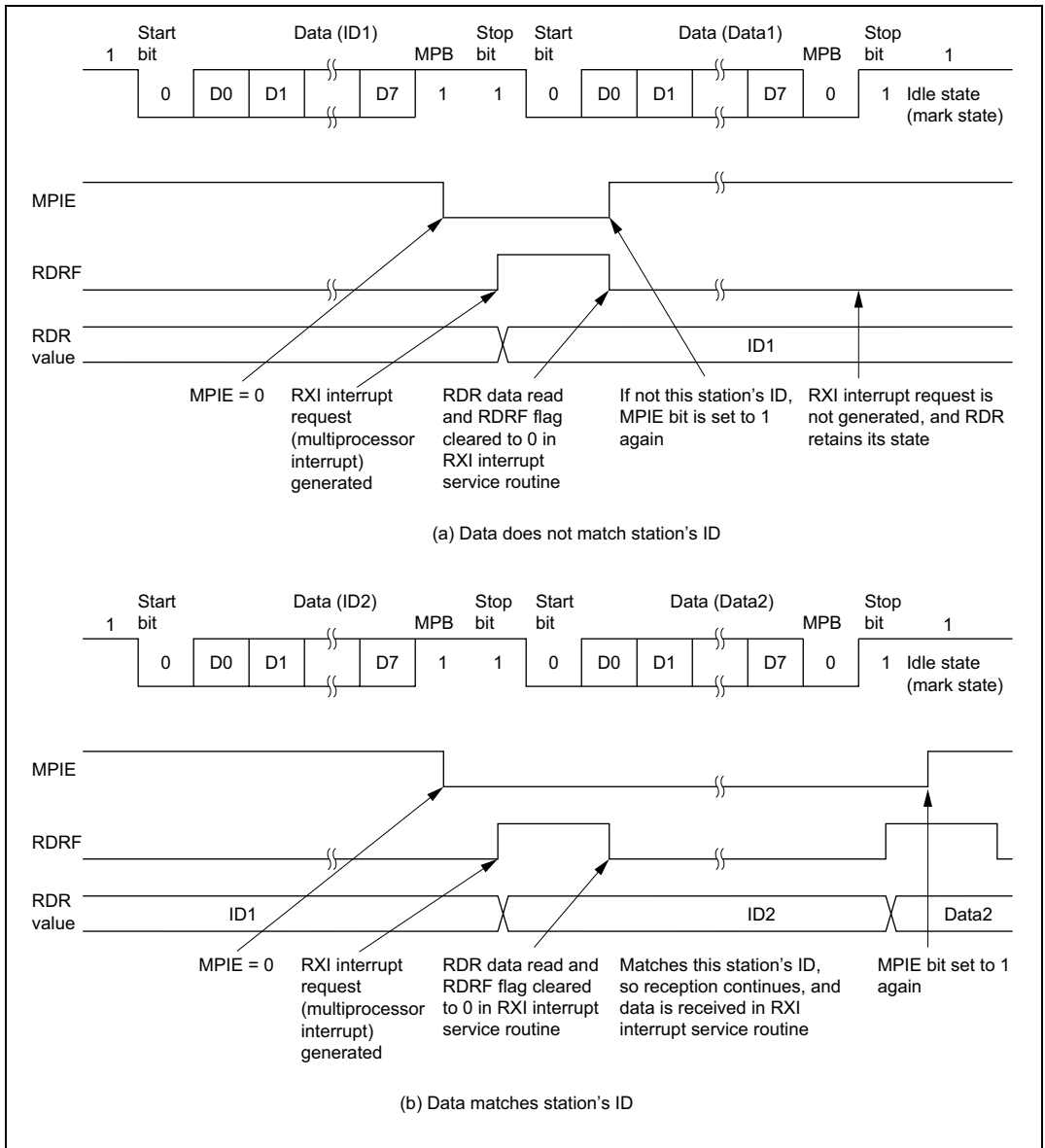

Figure 13-12 Sample Multiprocessor Serial Reception Flowchart (cont)

Figure 13-13 shows an example of SCI operation for multiprocessor format reception.



**Figure 13-13 Example of SCI Operation in Reception
(Example with 8-Bit Data, Multiprocessor Bit, One Stop Bit)**

13.3.4 Operation in Clocked Synchronous Mode

In clocked synchronous mode, data is transmitted or received in synchronization with clock pulses, making it suitable for high-speed serial communication.

Inside the SCI, the transmitter and receiver are independent units, enabling full-duplex communication by use of a common clock. Both the transmitter and the receiver also have a double-buffered structure, so that data can be read or written during transmission or reception, enabling continuous data transfer.

Figure 13-14 shows the general format for clocked synchronous serial communication.

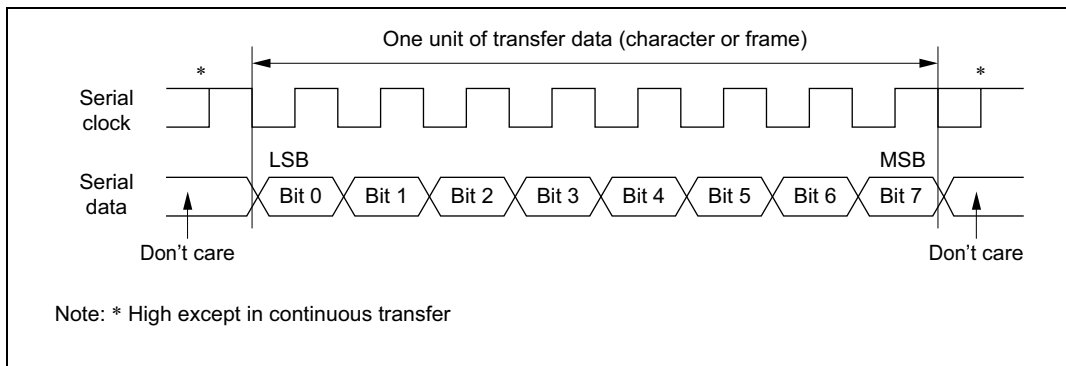

Figure 13-14 Data Format in Synchronous Communication

In clocked synchronous serial communication, data on the transmission line is output from one falling edge of the serial clock to the next. Data confirmation is guaranteed at the rising edge of the serial clock.

In clocked serial communication, one character consists of data output starting with the LSB and ending with the MSB. After the MSB is output, the transmission line holds the MSB state.

In clocked synchronous mode, the SCI receives data in synchronization with the rising edge of the serial clock.

Data Transfer Format: A fixed 8-bit data format is used.

No parity or multiprocessor bits are added.

Clock: Either an internal clock generated by the on-chip baud rate generator or an external serial clock input at the SCK pin can be selected, according to the setting of the C/\bar{A} bit in SMR and the CKE1 and CKE0 bits in SCR. For details of SCI clock source selection, see table 13-9.

When the SCI is operated on an internal clock, the serial clock is output from the SCK pin.

Eight serial clock pulses are output in the transfer of one character, and when no transfer is performed the clock is fixed high. When only receive operations are performed, however, the serial clock is output until an overrun error occurs or the RE bit is cleared to 0. If you want to perform receive operations in units of one character, you should select an external clock as the clock source.

Data Transfer Operations:

- **SCI initialization (clocked synchronous mode)**

Before transmitting and receiving data, you should first clear the TE and RE bits in SCR to 0, then initialize the SCI as described below.

When the operating mode, transfer format, etc., is changed, the TE and RE bits must be cleared to 0 before making the change using the following procedure. When the TE bit is cleared to 0, the TDRE flag is set to 1 and TSR is initialized. Note that clearing the RE bit to 0 does not change the contents of the RDRF, PER, FER, and ORER flags, or the contents of RDR.

Figure 13-15 shows a sample SCI initialization flowchart.

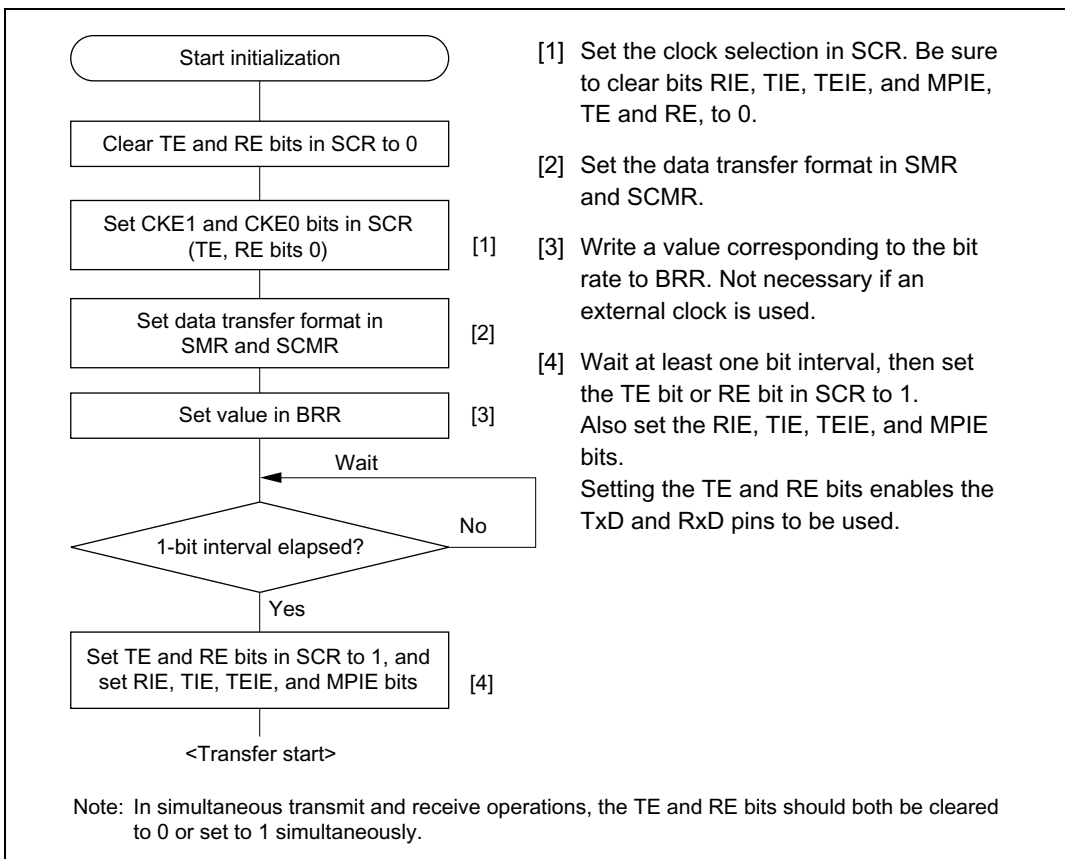

Figure 13-15 Sample SCI Initialization Flowchart

- Serial data transmission (clocked synchronous mode)

Figure 13-16 shows a sample flowchart for serial transmission.

The following procedure should be used for serial data transmission.

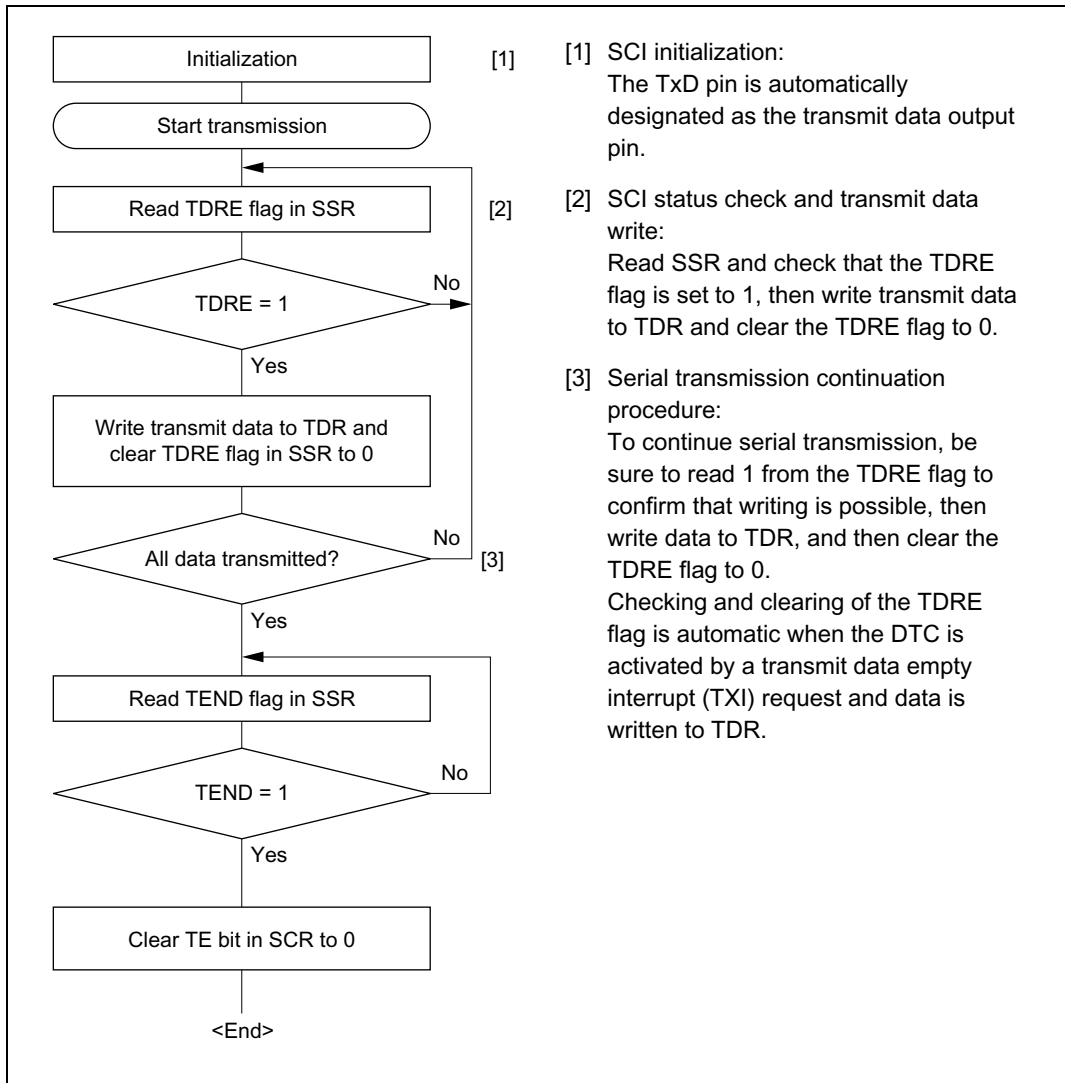

Figure 13-16 Sample Serial Transmission Flowchart

In serial transmission, the SCI operates as described below.

- [1] The SCI monitors the TDRE flag in SSR, and if it is 0, recognizes that data has been written to TDR, and transfers the data from TDR to TSR.
- [2] After transferring data from TDR to TSR, the SCI sets the TDRE flag to 1 and starts transmission. If the TIE bit in SCR is set to 1 at this time, a transmit data empty interrupt (TXI) is generated.
When clock output mode has been set, the SCI outputs 8 serial clock pulses. When use of an external clock has been specified, data is output synchronized with the input clock.
The serial transmit data is sent from the TxD pin starting with the LSB (bit 0) and ending with the MSB (bit 7).
- [3] The SCI checks the TDRE flag at the timing for sending the MSB (bit 7).
If the TDRE flag is cleared to 0, data is transferred from TDR to TSR, and serial transmission of the next frame is started.
If the TDRE flag is set to 1, the TEND flag in SSR is set to 1, the MSB (bit 7) is sent, and the TxD pin maintains its state.
If the TEIE bit in SCR is set to 1 at this time, a TEI interrupt request is generated.
- [4] After completion of serial transmission, the SCK pin is fixed high.
Figure 13-17 shows an example of SCI operation in transmission.

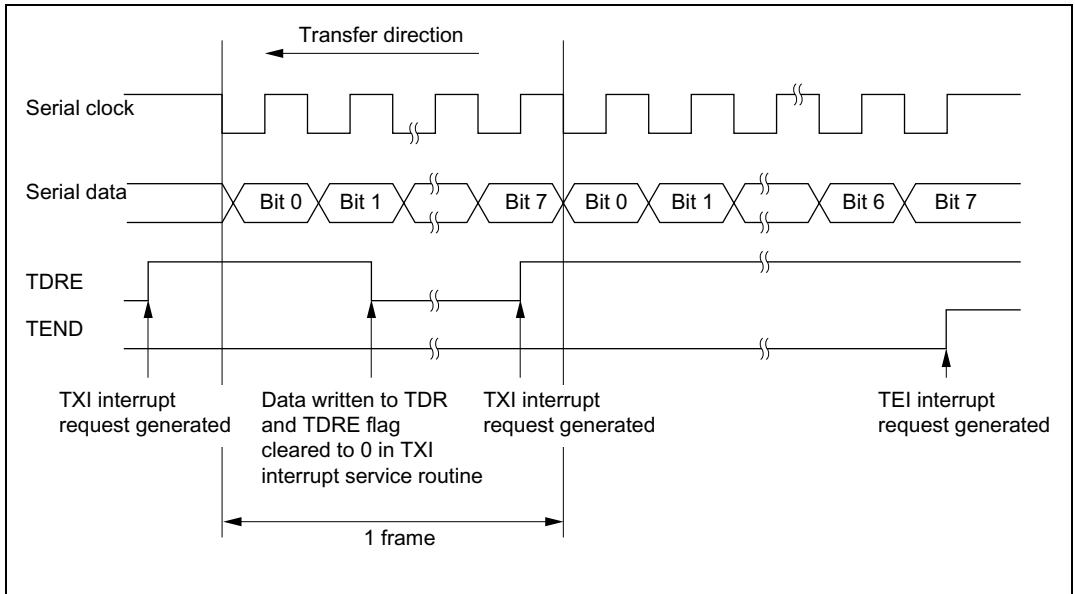

Figure 13-17 Example of SCI Operation in Transmission

- Serial data reception (clocked synchronous mode)

Figure 13-18 shows a sample flowchart for serial reception.

The following procedure should be used for serial data reception.

When changing the operating mode from asynchronous to clocked synchronous, be sure to check that the ORER, PER, and FER flags are all cleared to 0.

The RDRF flag will not be set if the FER or PER flag is set to 1, and neither transmit nor receive operations will be possible.

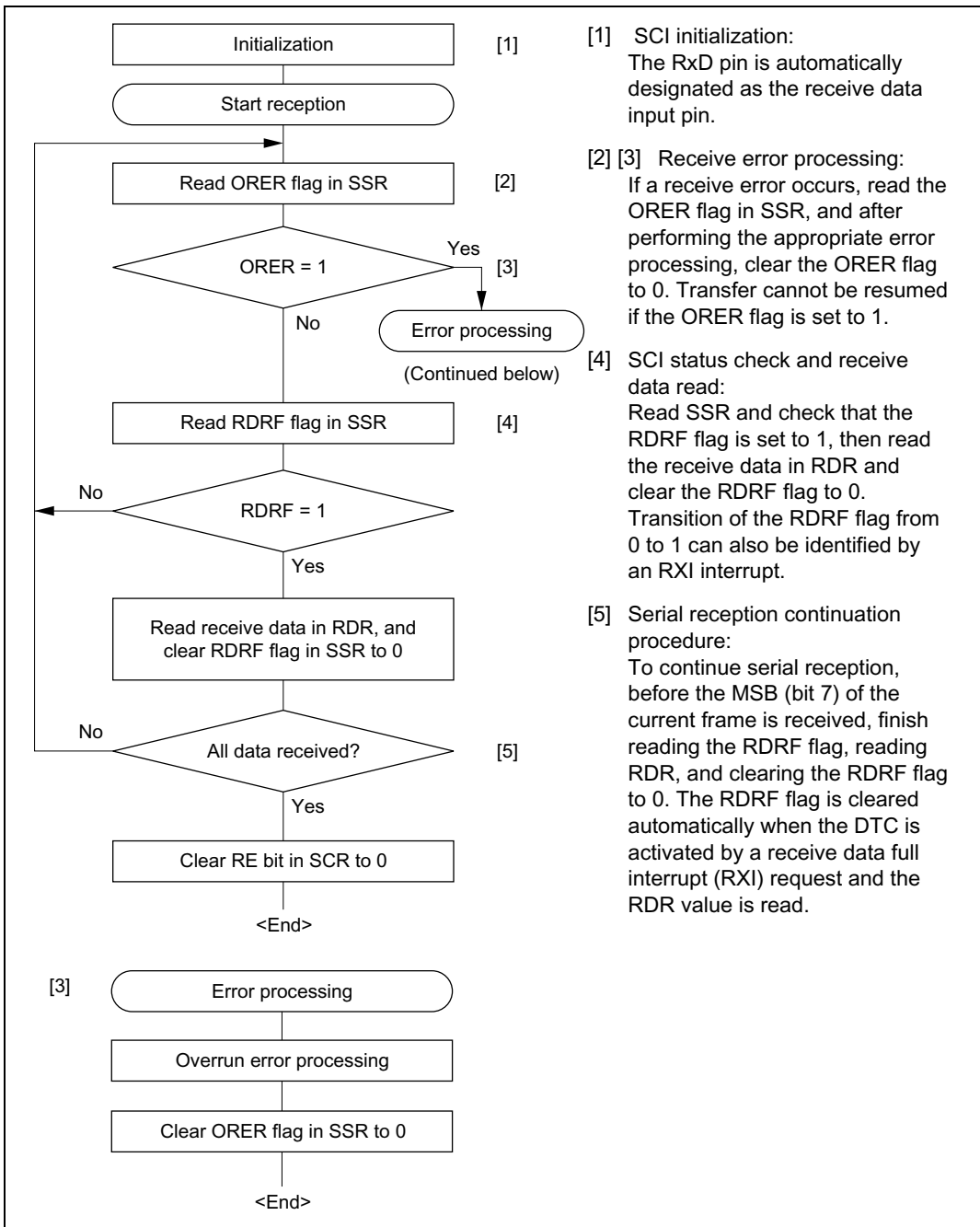

Figure 13-18 Sample Serial Reception Flowchart

In serial reception, the SCI operates as described below.

[1] The SCI performs internal initialization in synchronization with serial clock input or output.

[2] The received data is stored in RSR in LSB-to-MSB order.

After reception, the SCI checks whether the RDRF flag is 0 and the receive data can be transferred from RSR to RDR.

If this check is passed, the RDRF flag is set to 1, and the receive data is stored in RDR. If a receive error is detected in the error check, the operation is as shown in table 13-11.

Neither transmit nor receive operations can be performed subsequently when a receive error has been found in the error check.

[3] If the RIE bit in SCR is set to 1 when the RDRF flag changes to 1, a receive data full interrupt (RXI) request is generated.

Also, if the RIE bit in SCR is set to 1 when the ORER flag changes to 1, a receive error interrupt (ERI) request is generated.

Figure 13-19 shows an example of SCI operation in reception.

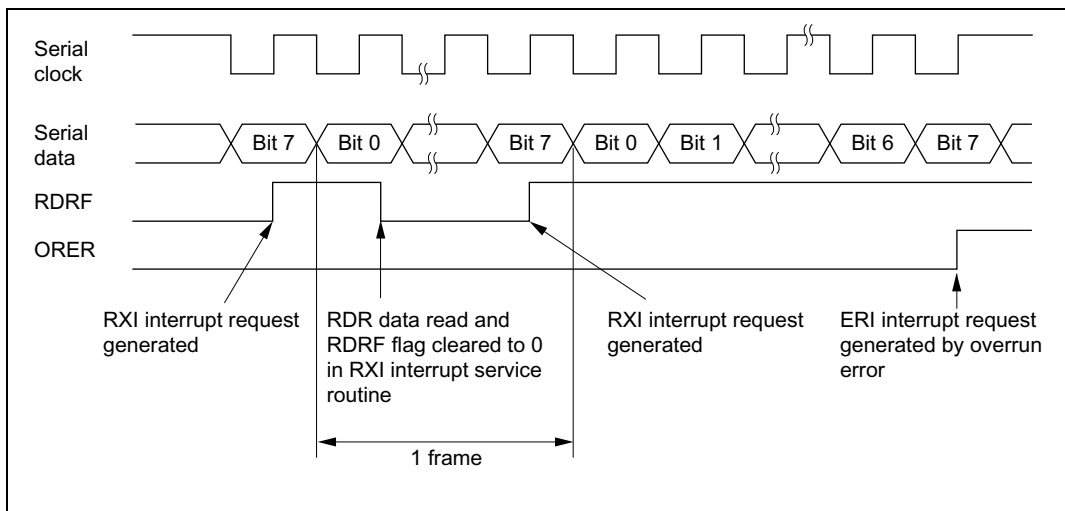
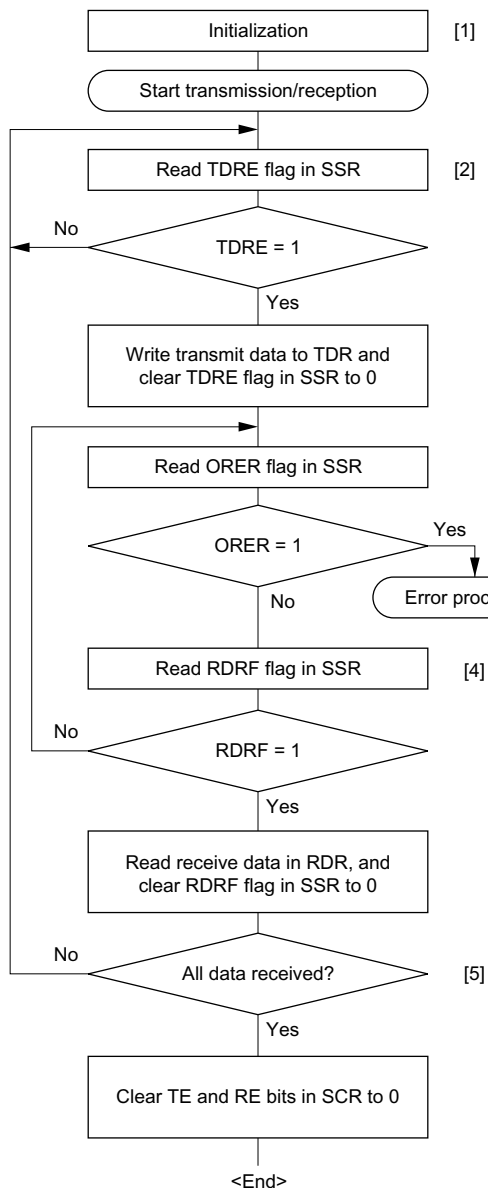

Figure 13-19 Example of SCI Operation in Reception

- Simultaneous serial data transmission and reception (clocked synchronous mode)

Figure 13-20 shows a sample flowchart for simultaneous serial transmit and receive operations.

The following procedure should be used for simultaneous serial data transmit and receive operations.



- [1] SCI initialization:
The TxD pin is designated as the transmit data output pin, and the RxD pin is designated as the receive data input pin, enabling simultaneous transmit and receive operations.
- [2] SCI status check and transmit data write:
Read SSR and check that the TDRE flag is set to 1, then write transmit data to TDR and clear the TDRE flag to 0. Transition of the TDRE flag from 0 to 1 can also be identified by a TXI interrupt.
- [3] Receive error processing:
If a receive error occurs, read the ORER flag in SSR, and after performing the appropriate error processing, clear the ORER flag to 0. Transmission/reception cannot be resumed if the ORER flag is set to 1.
- [4] SCI status check and receive data read:
Read SSR and check that the RDRF flag is set to 1, then read the receive data in RDR and clear the RDRF flag to 0. Transition of the RDRF flag from 0 to 1 can also be identified by an RXI interrupt.
- [5] Serial transmission/reception continuation procedure:
To continue serial transmission/reception, before the MSB (bit 7) of the current frame is received, finish reading the RDRF flag, reading RDR, and clearing the RDRF flag to 0. Also, before the MSB (bit 7) of the current frame is transmitted, read 1 from the TDRE flag to confirm that writing is possible. Then write data to TDR and clear the TDRE flag to 0. Checking and clearing of the TDRE flag is automatic when the DTC is activated by a transmit data empty interrupt (TXI) request and data is written to TDR. Also, the RDRF flag is cleared automatically when the DTC is activated by a receive data full interrupt (RXI) request and the RDR value is read.

Note: When switching from transmit or receive operation to simultaneous transmit and receive operations, first clear the TE bit and RE bit to 0, then set both these bits to 1 simultaneously.

Figure 13-20 Sample Flowchart of Simultaneous Serial Transmit and Receive Operations

13.4 SCI Interrupts

The SCI has four interrupt sources: the transmit-end interrupt (TEI) request, receive-error interrupt (ERI) request, receive-data-full interrupt (RXI) request, and transmit-data-empty interrupt (TXI) request. Table 13-13 shows the interrupt sources and their relative priorities. Individual interrupt sources can be enabled or disabled with the TIE, RIE, and TEIE bits in the SCR. Each kind of interrupt request is sent to the interrupt controller independently.

When the TDRE flag in SSR is set to 1, a TXI interrupt request is generated. When the TEND flag in SSR is set to 1, a TEI interrupt request is generated. A TXI interrupt can activate the DTC to perform data transfer. The TDRE flag is cleared to 0 automatically when data transfer is performed by the DTC. The DTC cannot be activated by a TEI interrupt request.

When the RDRF flag in SSR is set to 1, an RXI interrupt request is generated. When the ORER, PER, or FER flag in SSR is set to 1, an ERI interrupt request is generated. An RXI interrupt can activate the DTC to perform data transfer. The RDRF flag is cleared to 0 automatically when data transfer is performed by the DTC. The DTC cannot be activated by an ERI interrupt request.

Table 13-12 SCI Interrupt Sources

Channel	Interrupt Source	Description	DTC Activation	Priority*
0	ERI	Interrupt due to receive error (ORER, FER, or PER)	Not possible	High ↑ Low
	RXI	Interrupt due to receive data full state (RDRF)	Possible	
	TXI	Interrupt due to transmit data empty state (TDRE)	Possible	
	TEI	Interrupt due to transmission end (TEND)	Not possible	
1	ERI	Interrupt due to receive error (ORER, FER, or PER)	Not possible	
	RXI	Interrupt due to receive data full state (RDRF)	Possible	
	TXI	Interrupt due to transmit data empty state (TDRE)	Possible	
	TEI	Interrupt due to transmission end (TEND)	Not possible	
2	ERI	Interrupt due to receive error (ORER, FER, or PER)	Not possible	
	RXI	Interrupt due to receive data full state (RDRF)	Possible	
	TXI	Interrupt due to transmit data empty state (TDRE)	Possible	
	TEI	Interrupt due to transmission end (TEND)	Not possible	

Note: * This table shows the initial state immediately after a reset. Relative priorities among channels can be changed by means of the interrupt controller.

A TEI interrupt is requested when the TEND flag is set to 1 while the TEIE bit is set to 1. The TEND flag is cleared at the same time as the TDRE flag. Consequently, if a TEI interrupt and a

TXI interrupt are requested simultaneously, the TXI interrupt may have priority for acceptance, with the result that the TDRE and TEND flags are cleared. Note that the TEI interrupt will not be accepted in this case.

13.5 Usage Notes

The following points should be noted when using the SCI.

Relation between Writes to TDR and the TDRE Flag

The TDRE flag in SSR is a status flag that indicates that transmit data has been transferred from TDR to TSR. When the SCI transfers data from TDR to TSR, the TDRE flag is set to 1.

Data can be written to TDR regardless of the state of the TDRE flag. However, if new data is written to TDR when the TDRE flag is cleared to 0, the data stored in TDR will be lost since it has not yet been transferred to TSR. It is therefore essential to check that the TDRE flag is set to 1 before writing transmit data to TDR.

Operation when Multiple Receive Errors Occur Simultaneously

If a number of receive errors occur at the same time, the state of the status flags in SSR is as shown in table 13-14. If there is an overrun error, data is not transferred from RSR to RDR, and the receive data is lost.

Table 13-13 State of SSR Status Flags and Transfer of Receive Data

SSR Status Flags				Receive Data Transfer	Receive Error Status
RDRF	ORER	FER	PER	RSR to RDR	
1	1	0	0	X	Overrun error
0	0	1	0	○	Framing error
0	0	0	1	○	Parity error
1	1	1	0	X	Overrun error + framing error
1	1	0	1	X	Overrun error + parity error
0	0	1	1	○	Framing error + parity error
1	1	1	1	X	Overrun error + framing error + parity error

Notes: ○ : Receive data is transferred from RSR to RDR.

X: Receive data is not transferred from RSR to RDR.

Break Detection and Processing (Asynchronous Mode Only): When framing error (FER) detection is performed, a break can be detected by reading the RxD pin value directly. In a break, the input from the RxD pin becomes all 0s, and so the FER flag is set, and the parity error flag (PER) may also be set.

Note that, since the SCI continues the receive operation after receiving a break, even if the FER flag is cleared to 0, it will be set to 1 again.

Sending a Break (Asynchronous Mode Only): The TxD pin has a dual function as an I/O port whose direction (input or output) is determined by DR and DDR. This can be used to send a break.

Between serial transmission initialization and setting of the TE bit to 1, the mark state is replaced by the value of DR (the pin does not function as the TxD pin until the TE bit is set to 1). Consequently, DDR and DR for the port corresponding to the TxD pin are first set to 1.

To send a break during serial transmission, first clear DR to 0, then clear the TE bit to 0.

When the TE bit is cleared to 0, the transmitter is initialized regardless of the current transmission state, the TxD pin becomes an I/O port, and 0 is output from the TxD pin.

Receive Error Flags and Transmit Operations (Clocked Synchronous Mode Only):

Transmission cannot be started when a receive error flag (ORER, PER, or FER) is set to 1, even if the TDRE flag is cleared to 0. Be sure to clear the receive error flags to 0 before starting transmission.

Note also that receive error flags cannot be cleared to 0 even if the RE bit is cleared to 0.

Receive Data Sampling Timing and Reception Margin in Asynchronous Mode:

In asynchronous mode, the SCI operates on a basic clock with a frequency of 16 times the transfer rate.

In reception, the SCI samples the falling edge of the start bit using the basic clock, and performs internal synchronization. Receive data is latched internally at the rising edge of the 8th pulse of the basic clock. This is illustrated in figure 13-21.

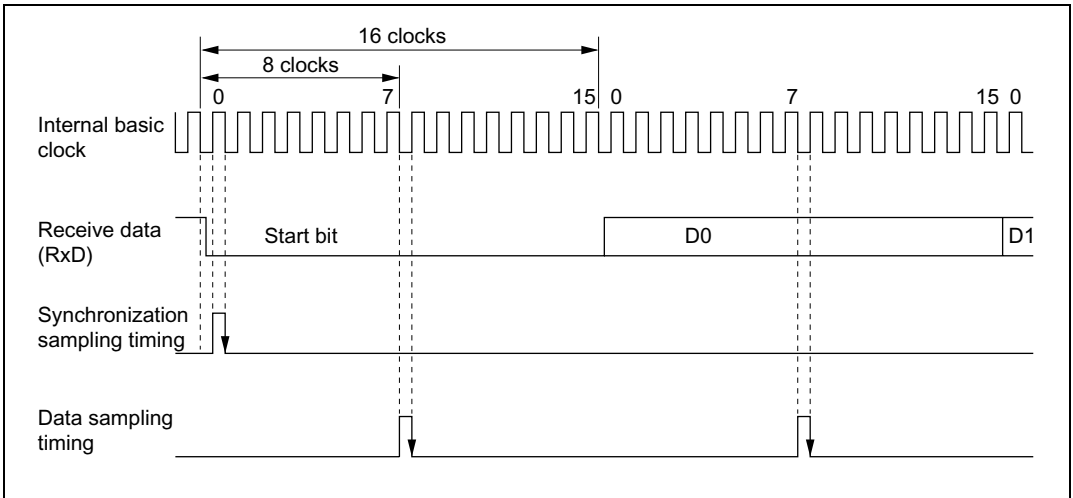

Figure 13-21 Receive Data Sampling Timing in Asynchronous Mode

Thus the reception margin in asynchronous mode is given by formula (1) below.

$$M = \left| \left(0.5 - \frac{1}{2N} \right) - (L - 0.5) F - \frac{|D - 0.5|}{N} (1 + F) \right| \times 100\%$$

... Formula (1)

Where M : Reception margin (%)
 N : Ratio of bit rate to clock (N = 16)
 D : Clock duty (D = 0 to 1.0)
 L : Frame length (L = 9 to 12)
 F : Absolute value of clock rate deviation

Assuming values of F = 0 and D = 0.5 in formula (1), a reception margin of 46.875% is given by formula (2) below.

When D = 0.5 and F = 0,

$$M = \left(0.5 - \frac{1}{2 \times 16} \right) \times 100\% \\ = 46.875\%$$

... Formula (2)

However, this is only the computed value, and a margin of 20% to 30% should be allowed in system design.

Restrictions on Use of DTC*

Note: * The DTC is not implemented in the H8S/2635 and H8S/2634.

- When an external clock source is used as the serial clock, the transmit clock should not be input until at least 5 ϕ clock cycles after TDR is updated by the DTC. Misoperation may occur if the transmit clock is input within 4 ϕ clocks after TDR is updated (figure 13-22).
- When RDR is read by the DTC, be sure to set the activation source to the relevant SCI reception end interrupt (RXI).

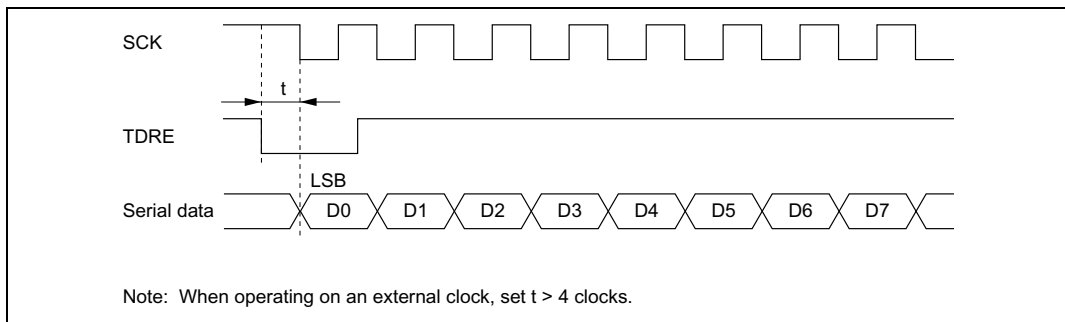

Figure 13-22 Example of Clocked Synchronous Transmission by DTC

Operation in Case of Mode Transition

• Transmission

Operation should be stopped (by clearing TE, TIE, and TEIE to 0) before making a module stop mode, software standby mode, watch mode, subactive mode, or subsleep mode transition. TSR, TDR, and SSR are reset. The output pin states in module stop mode, software standby mode, watch mode, subactive mode, or subsleep mode depend on the port settings, and becomes high-level output after the relevant mode is cleared. If a transition is made during transmission, the data being transmitted will be undefined. When transmitting without changing the transmit mode after the relevant mode is cleared, transmission can be started by setting TE to 1 again, and performing the following sequence: SSR read -> TDR write -> TDRE clearance. To transmit with a different transmit mode after clearing the relevant mode, the procedure must be started again from initialization. Figure 13-23 shows a sample flowchart for mode transition during transmission. Port pin states are shown in figures 13-24 and 13-25. Operation should also be stopped (by clearing TE, TIE, and TEIE to 0) before making a transition from transmission by DTC* transfer to module stop mode, software standby mode, watch mode, subactive mode, or subsleep mode transition. To perform transmission with the DTC* after the relevant mode is cleared, setting TE and TIE to 1 will set the TXI flag and start DTC* transmission.

Note: * The DTC is not implemented in the H8S/2635 and H8S/2634.

- Reception

Receive operation should be stopped (by clearing RE to 0) before making a module stop mode, software standby mode, watch mode, subactive mode, or subsleep mode transition. RSR, RDR, and SSR are reset. If a transition is made without stopping reception, the data being received will be invalid.

To continue receiving without changing the reception mode after the relevant mode is cleared, set RE to 1 before starting reception. To receive with a different receive mode, the procedure must be started again from initialization.

Figure 13-26 shows a sample flowchart for mode transition during reception.

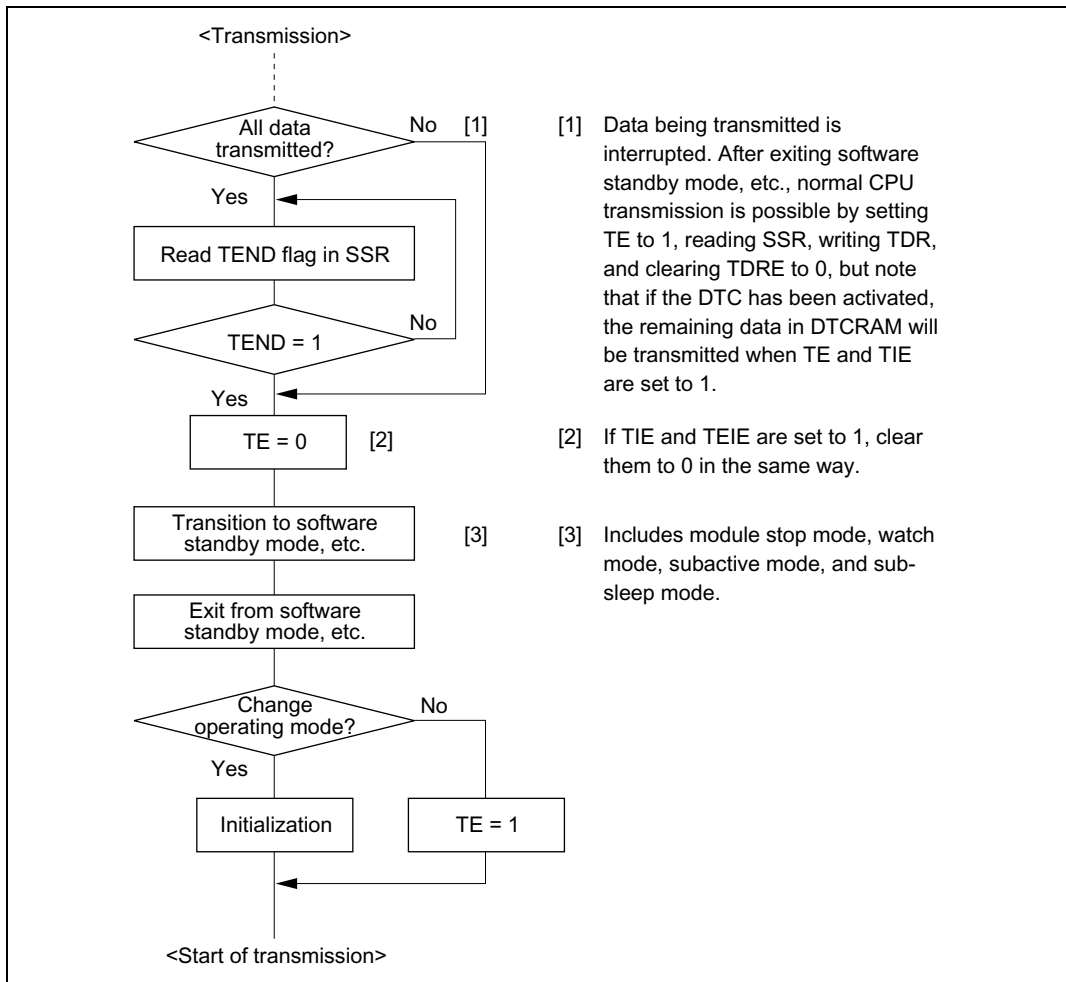

Figure 13-23 Sample Flowchart for Mode Transition during Transmission

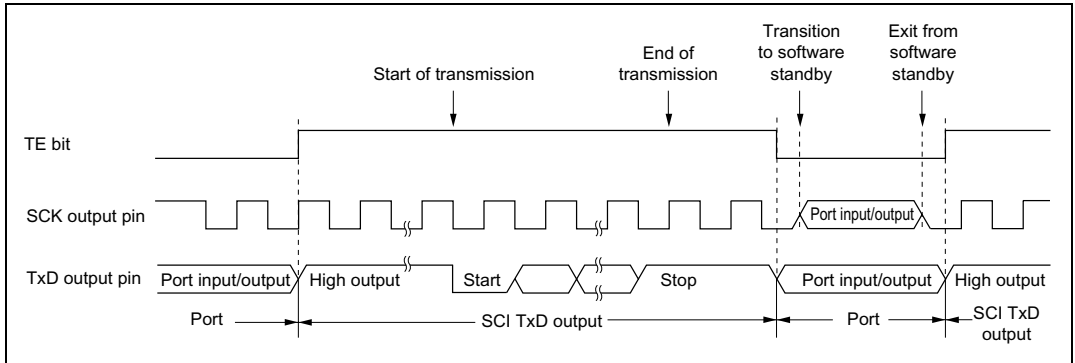

Figure 13-24 Asynchronous Transmission Using Internal Clock

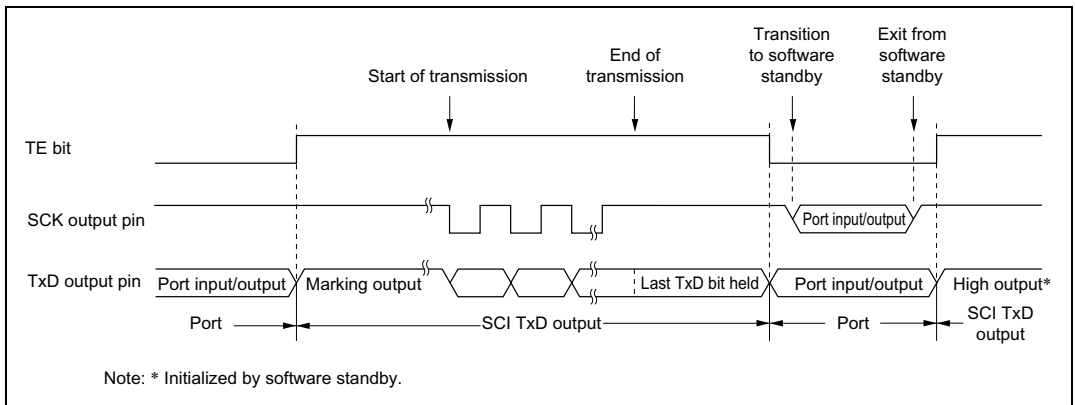

Figure 13-25 Synchronous Transmission Using Internal Clock

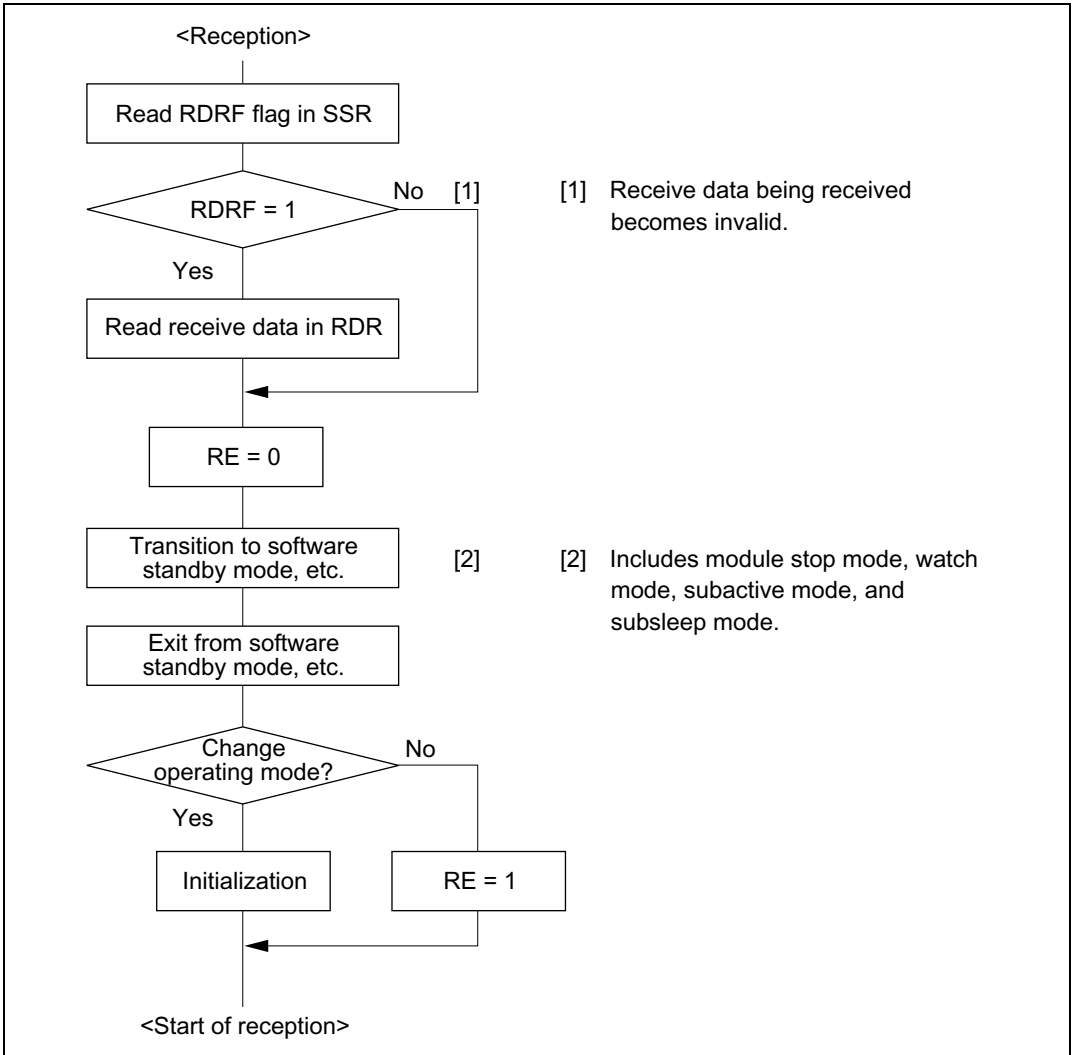

Figure 13-26 Sample Flowchart for Mode Transition during Reception

Switching from SCK Pin Function to Port Pin Function:

- Problem in Operation: When switching the SCK pin function to the output port function (high-level output) by making the following settings while $DDR = 1$, $DR = 1$, $C/\bar{A} = 1$, $CKE1 = 0$, $CKE0 = 0$, and $TE = 1$ (synchronous mode), low-level output occurs for one half-cycle.
1. End of serial data transmission
 2. TE bit = 0
 3. C/\bar{A} bit = 0 ... switchover to port output
 4. Occurrence of low-level output (see figure 13-27)

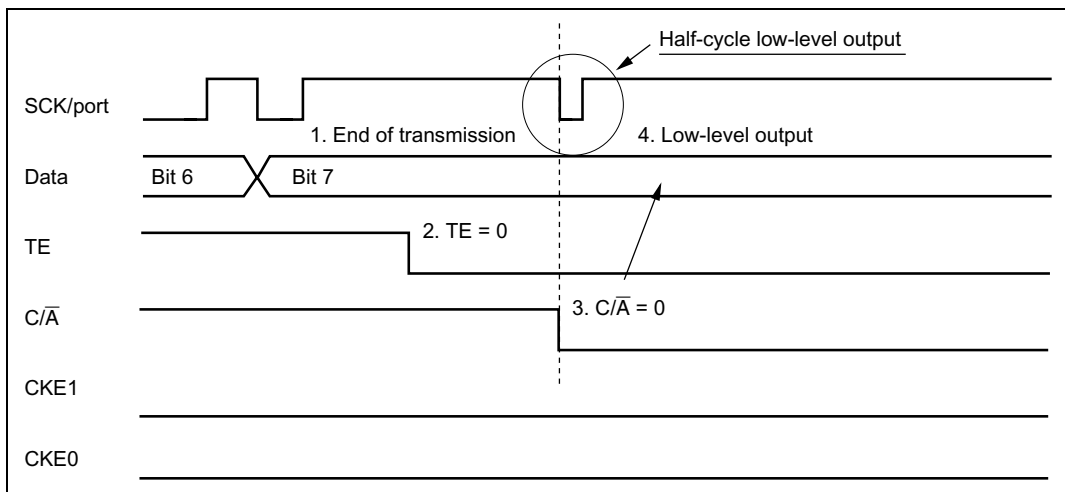
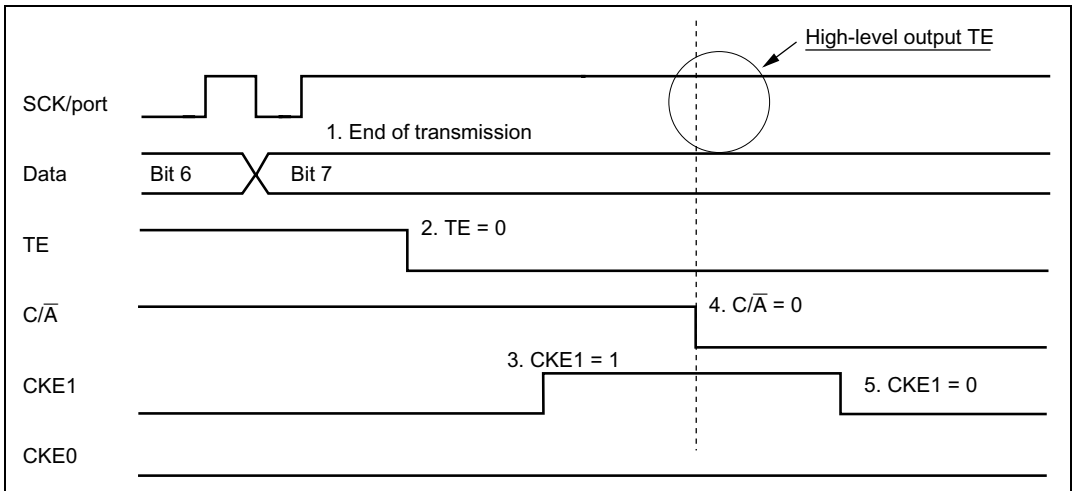

Figure 13-27 Operation when Switching from SCK Pin Function to Port Pin Function

- **Sample Procedure for Avoiding Low-Level Output:** As this sample procedure temporarily places the SCK pin in the input state, the SCK/port pin should be pulled up beforehand with an external circuit.

With $DDR = 1$, $DR = 1$, $C/\bar{A} = 1$, $CKE1 = 0$, $CKE0 = 0$, and $TE = 1$, make the following settings in the order shown.

1. End of serial data transmission
2. TE bit = 0
3. $CKE1$ bit = 1
4. C/\bar{A} bit = 0 ... switchover to port output
5. $CKE1$ bit = 0



**Figure 13-28 Operation when Switching from SCK Pin Function to Port Pin Function
(Example of Preventing Low-Level Output)**

Section 14 Smart Card Interface

Note: The H8S/2635 Group is not equipped with a DTC.

14.1 Overview

SCI supports an IC card (Smart Card) interface conforming to ISO/IEC 7816-3 (Identification Card) as a serial communication interface extension function.

Switching between the normal serial communication interface and the Smart Card interface is carried out by means of a register setting.

14.1.1 Features

Features of the Smart Card interface supported by the chip are as follows.

- Asynchronous mode
 - Data length: 8 bits
 - Parity bit generation and checking
 - Transmission of error signal (parity error) in receive mode
 - Error signal detection and automatic data retransmission in transmit mode
 - Direct convention and inverse convention both supported
- On-chip baud rate generator allows any bit rate to be selected
- Three interrupt sources
 - Three interrupt sources (transmit data empty, receive data full, and transmit/receive error) that can issue requests independently
 - The transmit data empty interrupt and receive data full interrupt can activate the data transfer controller (DTC)* to execute data transfer

Note: * The DTC is not implemented in the H8S/2635 and H8S/2634.

14.1.2 Block Diagram

Figure 14-1 shows a block diagram of the Smart Card interface.

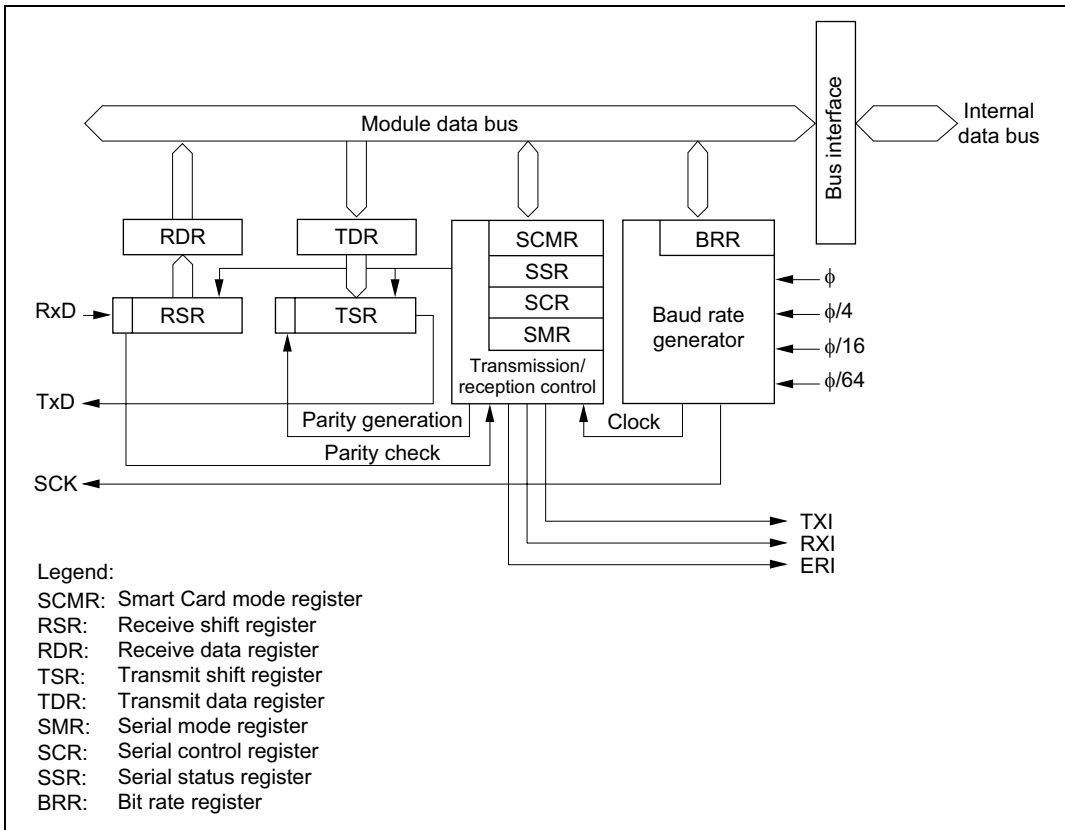

Figure 14-1 Block Diagram of Smart Card Interface

14.1.3 Pin Configuration

Table 14-1 shows the Smart Card interface pin configuration.

Table 14-1 Smart Card Interface Pins

Channel	Pin Name	Symbol	I/O	Function
0	Serial clock pin 0	SCK0	I/O	SCI0 clock input/output
	Receive data pin 0	RxD0	Input	SCI0 receive data input
	Transmit data pin 0	TxD0	Output	SCI0 transmit data output
1	Serial clock pin 1	SCK1	I/O	SCI1 clock input/output
	Receive data pin 1	RxD1	Input	SCI1 receive data input
	Transmit data pin 1	TxD1	Output	SCI1 transmit data output
2	Serial clock pin 2	SCK2	I/O	SCI2 clock input/output
	Receive data pin 2	RxD2	Input	SCI2 receive data input
	Transmit data pin 2	TxD2	Output	SCI2 transmit data output

14.1.4 Register Configuration

Table 14-2 shows the registers used by the Smart Card interface. Details of SMR, BRR, SCR, TDR, RDR, and MSTPCR are the same as for the normal SCI function: see the register descriptions in section 13, Serial Communication Interface (SCI).

Table 14-2 Smart Card Interface Registers

Channel	Name	Abbreviation	R/W	Initial Value	Address* ¹
0	Serial mode register 0	SMR0	R/W	H'00	H'FF78
	Bit rate register 0	BRR0	R/W	H'FF	H'FF79
	Serial control register 0	SCR0	R/W	H'00	H'FF7A
	Transmit data register 0	TDR0	R/W	H'FF	H'FF7B
	Serial status register 0	SSR0	R/(W)* ²	H'84	H'FF7C
	Receive data register 0	RDR0	R	H'00	H'FF7D
	Smart card mode register 0	SCMR0	R/W	H'F2	H'FF7E
1	Serial mode register 1	SMR1	R/W	H'00	H'FF80
	Bit rate register 1	BRR1	R/W	H'FF	H'FF81
	Serial control register 1	SCR1	R/W	H'00	H'FF82
	Transmit data register 1	TDR1	R/W	H'FF	H'FF83
	Serial status register 1	SSR1	R/(W)* ²	H'84	H'FF84
	Receive data register 1	RDR1	R	H'00	H'FF85
	Smart card mode register 1	SCMR1	R/W	H'F2	H'FF86
2	Serial mode register 2	SMR2	R/W	H'00	H'FF88
	Bit rate register 2	BRR2	R/W	H'FF	H'FF89
	Serial control register 2	SCR2	R/W	H'00	H'FF8A
	Transmit data register 2	TDR2	R/W	H'FF	H'FF8B
	Serial status register 2	SSR2	R/(W)* ²	H'84	H'FF8C
	Receive data register 2	RDR2	R	H'00	H'FF8D
	Smart card mode register 2	SCMR2	R/W	H'F2	H'FF8E
All	Module stop control register B	MSTPCRB	R/W	H'FF	H'FDE9

Notes: 1. Lower 16 bits of the address.

2. Can only be written with 0 for flag clearing.

14.2 Register Descriptions

Registers added with the Smart Card interface and bits for which the function changes are described here.

14.2.1 Smart Card Mode Register (SCMR)

Bit	:	7	6	5	4	3	2	1	0
		—	—	—	—	SDIR	SINV	—	SMIF
Initial value	:	1	1	1	1	0	0	1	0
R/W	:	—	—	—	—	R/W	R/W	—	R/W

SCMR is an 8-bit readable/writable register that selects the Smart Card interface function.

SCMR is initialized to HF2 by a reset and in standby mode.

Bits 7 to 4—Reserved: These bits are always read as 1 and cannot be modified.

Bit 3—Smart Card Data Transfer Direction (SDIR): Selects the serial/parallel conversion format.

Bit 3

SDIR	Description
0	TDR contents are transmitted LSB-first Receive data is stored in RDR LSB-first (Initial value)
1	TDR contents are transmitted MSB-first Receive data is stored in RDR MSB-first

Bit 2—Smart Card Data Invert (SINV): Specifies inversion of the data logic level. This function is used together with the SDIR bit for communication with an inverse convention card. The SINV bit does not affect the logic level of the parity bit. For parity-related setting procedures, see section 14.3.4, Register Settings.

Bit 2 SINV	Description	
0	TDR contents are transmitted as they are Receive data is stored as it is in RDR	(Initial value)
1	TDR contents are inverted before being transmitted Receive data is stored in inverted form in RDR	

Bit 1—Reserved: This bit is always read as 1 and cannot be modified.

Bit 0—Smart Card Interface Mode Select (SMIF): Enables or disables the Smart Card interface function.

Bit 0 SMIF	Description	
0	Smart Card interface function is disabled	(Initial value)
1	Smart Card interface function is enabled	

14.2.2 Serial Status Register (SSR)

Bit	:	7	6	5	4	3	2	1	0
		TDRE	RDRF	ORER	ERS	PER	TEND	MPB	MPBT
Initial value :		1	0	0	0	0	1	0	0
R/W	:	R/(W)*	R/(W)*	R/(W)*	R/(W)*	R/(W)*	R	R	R/W

Note: * Only 0 can be written, to clear these flags.

Bit 4 of SSR has a different function in Smart Card interface mode. Coupled with this, the setting conditions for bit 2, TEND, are also different.

Bits 7 to 5—Operate in the same way as for the normal SCI. For details, see section 13.2.7, Serial Status Register (SSR).

Bit 4—Error Signal Status (ERS): In Smart Card interface mode, bit 4 indicates the status of the error signal sent back from the receiving end in transmission. Framing errors are not detected in Smart Card interface mode.

Bit 4

ERS	Description
0	Normal reception, with no error signal [Clearing conditions] (Initial value) <ul style="list-style-type: none"> • Upon reset, and in standby mode or module stop mode • When 0 is written to ERS after reading ERS = 1
1	Error signal sent from receiver indicating detection of parity error [Setting condition] <ul style="list-style-type: none"> • When the Low level of the error signal is sampled

Note: Clearing the TE bit in SCR to 0 does not affect the ERS flag, which retains its previous state.

Bits 3 to 0—Operate in the same way as for the normal SCI. For details, see section 13.2.7, Serial Status Register (SSR).

However, the setting conditions for the TEND bit, are as shown below.

Bit 2

TEND	Description
0	Transmission is in progress [Clearing conditions] (Initial value) <ul style="list-style-type: none"> • When 0 is written to TDRE after reading TDRE = 1 • When the DTC is activated by a TXI interrupt and write data to TDR
1	Transmission has ended [Setting conditions] <ul style="list-style-type: none"> • Upon reset, and in standby mode or module stop mode • When the TE bit in SCR is 0 and the ERS bit is also 0 • When TDRE = 1 and ERS = 0 (normal transmission) 2.5 etu after transmission of a 1-byte serial character when GM = 0 and BLK = 0 • When TDRE = 1 and ERS = 0 (normal transmission) 1.5 etu after transmission of a 1-byte serial character when GM = 0 and BLK = 1 • When TDRE = 1 and ERS = 0 (normal transmission) 1.0 etu after transmission of a 1-byte serial character when GM = 1 and BLK = 0 • When TDRE = 1 and ERS = 0 (normal transmission) 1.0 etu after transmission of a 1-byte serial character when GM = 1 and BLK = 1

Note: etu: Elementary Time Unit (time for transfer of 1 bit)

14.2.3 Serial Mode Register (SMR)

Bit	:	7	6	5	4	3	2	1	0
		GM	BLK	PE	O/ \bar{E}	BCP1	BCP0	CKS1	CKS0
Initial value :		0	0	0	0	0	0	0	0
R/W	:	R/W	R/W	R/W	R/W	R/W	R/W	R/W	R/W

Note: When the smart card interface is used, be sure to make the 1 setting shown for bit 5.

The function of bits 7, 6, 3, and 2 of SMR changes in Smart Card interface mode.

Bit 7—GSM Mode (GM): Sets the smart card interface function to GSM mode.

This bit is cleared to 0 when the normal smart card interface is used. In GSM mode, this bit is set to 1, the timing of setting of the TEND flag that indicates transmission completion is advanced and clock output control mode addition is performed. The contents of the clock output control mode addition are specified by bits 1 and 0 of the serial control register (SCR).

Bit 7

GM	Description
0	Normal smart card interface mode operation (Initial value) <ul style="list-style-type: none"> TEND flag generation 12.5 etu (11.5 etu in block transfer mode) after beginning of start bit Clock output ON/OFF control only
1	GSM mode smart card interface mode operation <ul style="list-style-type: none"> TEND flag generation 11.0 etu after beginning of start bit High/Low fixing control possible in addition to clock output ON/OFF control (set by SCR)

Note: etu: Elementary Time Unit (time for transfer of 1 bit)

Bit 6—Block Transfer Mode (BLK): Selects block transfer mode.

Bit 6

BLK	Description
0	Normal Smart Card interface mode operation <ul style="list-style-type: none"> • Error signal transmission/detection and automatic data retransmission performed • TXI interrupt generated by TEND flag • TEND flag set 12.5 etu after start of transmission (11.0 etu in GSM mode)
1	Block transfer mode operation <ul style="list-style-type: none"> • Error signal transmission/detection and automatic data retransmission not performed • TXI interrupt generated by TDRE flag • TEND flag set 11.5 etu after start of transmission (11.0 etu in GSM mode)

Note: etu: Elementary Time Unit (time for transfer of 1 bit)

Bits 3 and 2—Basic Clock Pulse 1 and 2 (BCP1, BCP0): These bits specify the number of basic clock periods in a 1-bit transfer interval on the Smart Card interface.

Bit 3	Bit 2	Description
BCP1	BCP0	
0	0	32 clock periods (Initial value)
	1	64 clock periods
1	0	372 clock periods
	1	256 clock periods

Bits 5, 4, 1, and 0: Operate in the same way as for the normal SCI. For details, see section 13.2.5, Serial Mode Register (SMR).

14.2.4 Serial Control Register (SCR)

Bit	:	7	6	5	4	3	2	1	0
		TIE	RIE	TE	RE	MPIE	TEIE	CKE1	CKE0
Initial value :		0	0	0	0	0	0	0	0
R/W	:	R/W	R/W	R/W	R/W	R/W	R/W	R/W	R/W

In smart card interface mode, the function of bits 1 and 0 of SCR changes when bit 7 of the serial mode register (SMR) is set to 1.

Bits 7 to 2—Operate in the same way as for the normal SCI.

For details, see section 13.2.6, Serial Control Register (SCR).

Bits 1 and 0—Clock Enable 1 and 0 (CKE1, CKE0): These bits are used to select the SCI clock source and enable or disable clock output from the SCK pin.

In smart card interface mode, in addition to the normal switching between clock output enabling and disabling, the clock output can be specified as to be fixed high or low.

SCMR	SMR	SCR Setting		SCK Pin Function
SMIF	C/ \bar{A} , GM	CKE1	CKE0	
0	See the SCI			
1	0	0	0	Operates as port I/O pin
1	0	0	1	Outputs clock as SCK output pin
1	1	0	0	Operates as SCK output pin, with output fixed low
1	1	0	1	Outputs clock as SCK output pin
1	1	1	0	Operates as SCK output pin, with output fixed high
1	1	1	1	Outputs clock as SCK output pin

14.3 Operation

14.3.1 Overview

The main functions of the Smart Card interface are as follows.

- One frame consists of 8-bit data plus a parity bit.
- In transmission, a guard time of at least 2 etu (Elementary Time Unit: the time for transfer of 1 bit) is left between the end of the parity bit and the start of the next frame.
- If a parity error is detected during reception, a low error signal level is output for one etu period, 10.5 etu after the start bit.
- If the error signal is sampled during transmission, the same data is transmitted automatically after the elapse of 2 etu or longer (except in block transfer mode).
- Only asynchronous communication is supported; there is no clocked synchronous communication function.

Note: etu: Elementary time unit (time for transfer of 1 bit)

14.3.2 Pin Connections

Figure 14-2 shows a schematic diagram of Smart Card interface related pin connections.

In communication with an IC card, since both transmission and reception are carried out on a single data transmission line, the TxD pin and RxD pin should be connected with the LSI pin. The data transmission line should be pulled up to the V_{CC} power supply with a resistor.

When the clock generated on the Smart Card interface is used by an IC card, the SCK pin output is input to the CLK pin of the IC card. No connection is needed if the IC card uses an internal clock.

LSI port output is used as the reset signal.

Other pins must normally be connected to the power supply or ground.

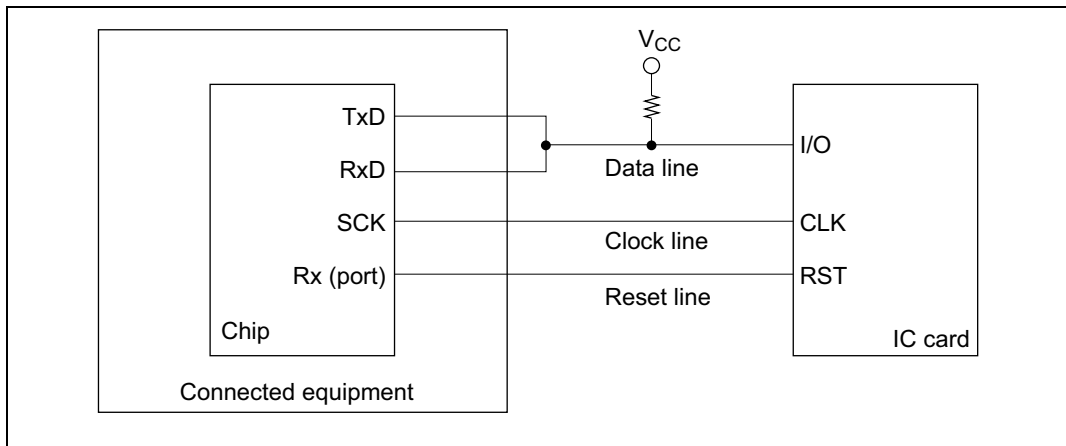

Figure 14-2 Schematic Diagram of Smart Card Interface Pin Connections

Note: If an IC card is not connected, and the TE and RE bits are both set to 1, closed transmission/reception is possible, enabling self-diagnosis to be carried out.

14.3.3 Data Format

Normal Transfer Mode: Figure 14-3 shows the normal Smart Card interface data format. In reception in this mode, a parity check is carried out on each frame, and if an error is detected an error signal is sent back to the transmitting end, and retransmission of the data is requested. If an error signal is sampled during transmission, the same data is retransmitted.

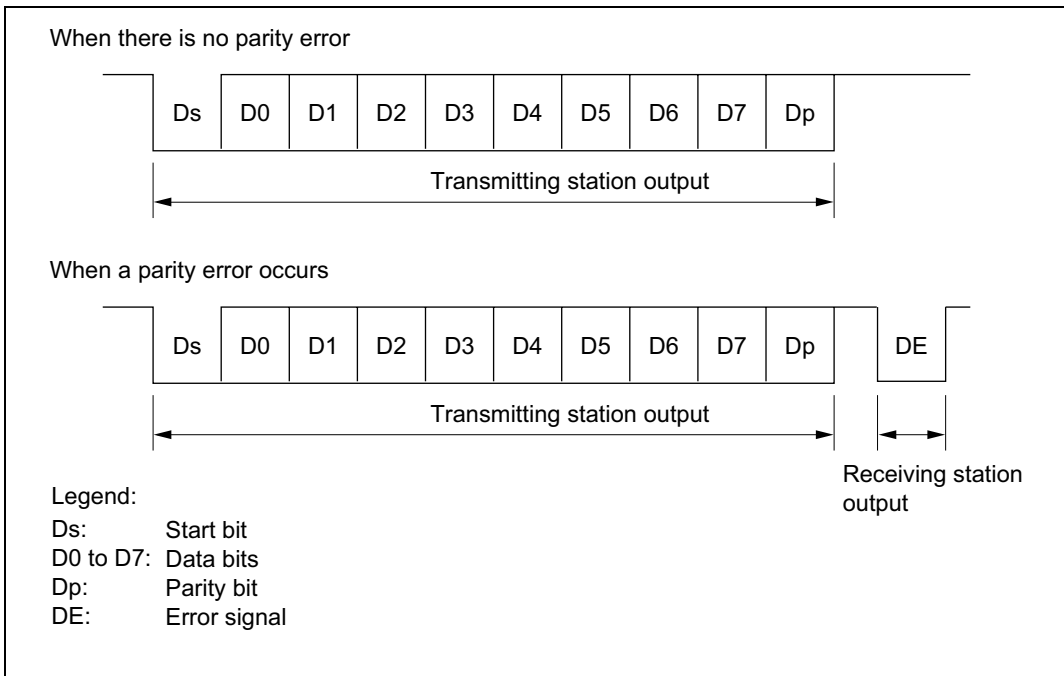

Figure 14-3 Normal Smart Card Interface Data Format

The operation sequence is as follows.

- [1] When the data line is not in use it is in the high-impedance state, and is fixed high with a pull-up resistor.
- [2] The transmitting station starts transfer of one frame of data. The data frame starts with a start bit (Ds, low-level), followed by 8 data bits (D0 to D7) and a parity bit (Dp).
- [3] With the Smart Card interface, the data line then returns to the high-impedance state. The data line is pulled high with a pull-up resistor.

[4] The receiving station carries out a parity check.

If there is no parity error and the data is received normally, the receiving station waits for reception of the next data.

If a parity error occurs, however, the receiving station outputs an error signal (DE, low-level) to request retransmission of the data. After outputting the error signal for the prescribed length of time, the receiving station places the signal line in the high-impedance state again. The signal line is pulled high again by a pull-up resistor.

[5] If the transmitting station does not receive an error signal, it proceeds to transmit the next data frame.

If it does receive an error signal, however, it returns to step [2] and retransmits the erroneous data.

Block Transfer Mode: The operation sequence in block transfer mode is as follows.

[1] When the data line is not in use it is in the high-impedance state, and is fixed high with a pull-up resistor.

[2] The transmitting station starts transfer of one frame of data. The data frame starts with a start bit (Ds, low-level), followed by 8 data bits (D0 to D7) and a parity bit (Dp).

[3] With the Smart Card interface, the data line then returns to the high-impedance state. The data line is pulled high with a pull-up resistor.

[4] After reception, a parity error check is carried out, but an error signal is not output even if an error has occurred. When an error occurs reception cannot be continued, so the error flag should be cleared to 0 before the parity bit of the next frame is received.

[5] The transmitting station proceeds to transmit the next data frame.

14.3.4 Register Settings

Table 14-3 shows a bit map of the registers used by the smart card interface.

Bits indicated as 0 or 1 must be set to the value shown. The setting of other bits is described below.

Table 14-3 Smart Card Interface Register Settings

Register	Bit							
	Bit 7	Bit 6	Bit 5	Bit 4	Bit 3	Bit 2	Bit 1	Bit 0
SMR	GM	BLK	1	O/ \bar{E}	BCP1	BCP0	CKS1	CKS0
BRR	BRR7	BRR6	BRR5	BRR4	BRR3	BRR2	BRR1	BRR0
SCR	TIE	RIE	TE	RE	0	0	CKE1*	CKE0
TDR	TDR7	TDR6	TDR5	TDR4	TDR3	TDR2	TDR1	TDR0
SSR	TDRE	RDRF	ORER	ERS	PER	TEND	0	0
RDR	RDR7	RDR6	RDR5	RDR4	RDR3	RDR2	RDR1	RDR0
SCMR	—	—	—	—	SDIR	SINV	—	SMIF

Notes: —: Unused bit.

*: The CKE1 bit must be cleared to 0 when the GM bit in SMR is cleared to 0.

SMR Setting: The GM bit is cleared to 0 in normal smart card interface mode, and set to 1 in GSM mode. The O/ \bar{E} bit is cleared to 0 if the IC card is of the direct convention type, and set to 1 if of the inverse convention type.

Bits CKS1 and CKS0 select the clock source of the on-chip baud rate generator. Bits BCP1 and BCP0 select the number of basic clock periods in a 1-bit transfer interval. For details, see section 14.3.5, Clock.

The BLK bit is cleared to 0 in normal smart card interface mode, and set to 1 in block transfer mode.

BRR Setting: BRR is used to set the bit rate. See section 14.3.5, Clock, for the method of calculating the value to be set.

SCR Setting: The function of the TIE, RIE, TE, and RE bits is the same as for the normal SCI. For details, see section 13, Serial Communication Interface (SCI).

Bits CKE1 and CKE0 specify the clock output. When the GM bit in SMR is cleared to 0, set these bits to B'00 if a clock is not to be output, or to B'01 if a clock is to be output. When the GM bit in SMR is set to 1, clock output is performed. The clock output can also be fixed high or low.

Smart Card Mode Register (SCMR) Setting: The SDIR bit is cleared to 0 if the IC card is of the direct convention type, and set to 1 if of the inverse convention type.

The SINV bit is cleared to 0 if the IC card is of the direct convention type, and set to 1 if of the inverse convention type.

The SMIF bit is set to 1 in the case of the Smart Card interface.

Examples of register settings and the waveform of the start character are shown below for the two types of IC card (direct convention and inverse convention).

- Direct convention ($SDIR = SINV = O/\bar{E} = 0$)

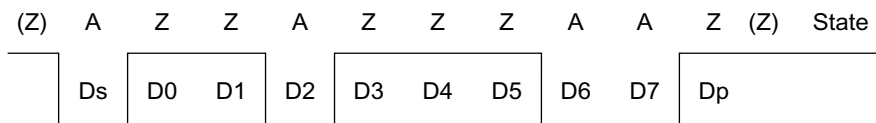

With the direct convention type, the logic 1 level corresponds to state Z and the logic 0 level to state A, and transfer is performed in LSB-first order. The start character data above is H'3B.

The parity bit is 1 since even parity is stipulated for the Smart Card.

- Inverse convention ($SDIR = SINV = O/\bar{E} = 1$)

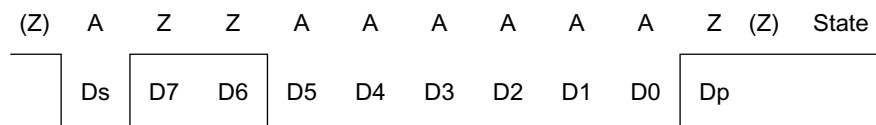

With the inverse convention type, the logic 1 level corresponds to state A and the logic 0 level to state Z, and transfer is performed in MSB-first order. The start character data above is H'3F.

The parity bit is 0, corresponding to state Z, since even parity is stipulated for the Smart Card.

With the H8S/2636, H8S/2638, H8S/2639, and H8S/2630 inversion specified by the SINV bit applies only to the data bits, D7 to D0. For parity bit inversion, the O/\bar{E} bit in SMR is set to odd parity mode (the same applies to both transmission and reception).

14.3.5 Clock

Only an internal clock generated by the on-chip baud rate generator can be used as the transmit/receive clock for the smart card interface. The bit rate is set with BRR and the CKS1, CKS0, BCP1 and BCP0 bits in SMR. The formula for calculating the bit rate is as shown below. Table 14-5 shows some sample bit rates.

If clock output is selected by setting CKE0 to 1, a clock is output from the SCK pin. The clock frequency is determined by the bit rate and the setting of bits BCP1 and BCP0.

$$B = \frac{\phi}{S \times 2^{2n+1} \times (N + 1)} \times 10^6$$

Where: N = Value set in BRR ($0 \leq N \leq 255$)

B = Bit rate (bit/s)

ϕ = Operating frequency (MHz)

n = See table 14-4

S = Number of internal clocks in 1-bit period, set by BCP1 and BCP0

Table 14-4 Correspondence between n and CKS1, CKS0

n	CKS1	CKS0
0	0	0
1		1
2	1	0
3		1

**Table 14-5 Examples of Bit Rate B (bit/s) for Various BRR Settings
(When n = 0 and S = 372)**

N	ϕ (MHz)						
	10.00	10.714	13.00	14.285	16.00	18.00	20.00
0	13441	14400	17473	19200	21505	24194	26882
1	6720	7200	8737	9600	10753	12097	13441
2	4480	4800	5824	6400	7168	8065	8961

Note: Bit rates are rounded to the nearest whole number.

The method of calculating the value to be set in the bit rate register (BRR) from the operating frequency and bit rate, on the other hand, is shown below. N is an integer, $0 \leq N \leq 255$, and the smaller error is specified.

$$N = \frac{\phi}{S \times 2^{2n+1} \times B} \times 10^6 - 1$$

Table 14-6 Examples of BRR Settings for Bit Rate B (bit/s) (When n = 0 and S = 372)

bit/s	ϕ (MHz)															
	7.1424		10.00		10.7136		13.00		14.2848		16.00		18.00		20.00	
	N	Error	N	Error	N	Error	N	Error	N	Error	N	Error	N	Error	N	Error
9600	0	0.00	1	30	1	25	1	8.99	1	0.00	1	12.01	2	15.99	2	6.60

Note: A blank means no setting is available.

**Table 14-7 Maximum Bit Rate at Various Frequencies (Smart Card Interface Mode)
(when S = 372)**

ϕ (MHz)	Maximum Bit Rate (bit/s)	N	n
7.1424	9600	0	0
10.00	13441	0	0
10.7136	14400	0	0
13.00	17473	0	0
14.2848	19200	0	0
16.00	21505	0	0
18.00	24194	0	0
20.00	26882	0	0

The bit rate error is given by the following formula:

$$\text{Error (\%)} = \left(\frac{\phi}{S \times 2^{2n+1} \times B \times (N + 1)} \times 10^6 - 1 \right) \times 100$$

14.3.6 Data Transfer Operations

Initialization: Before transmitting and receiving data, initialize the SCI as described below. Initialization is also necessary when switching from transmit mode to receive mode, or vice versa.

- [1] Clear the TE and RE bits in SCR to 0.
- [2] Clear the error flags ERS, PER, and ORER in SSR to 0.
- [3] Set the GM, BLK, O/\bar{E} , BCP1, BCP0, CKS1, CKS0 bits in SMR. Set the PE bit to 1.
- [4] Set the SMIF, SDIR, and SINV bits in SCMR.
When the SMIF bit is set to 1, the TxD and RxD pins are both switched from ports to SCI pins, and are placed in the high-impedance state.
- [5] Set the value corresponding to the bit rate in BRR.
- [6] Set the CKE0 and CKE1 bits in SCR. Clear the TIE, RIE, TE, RE, MPIE, and TEIE bits to 0.
If the CKE0 bit is set to 1, the clock is output from the SCK pin.
- [7] Wait at least one bit interval, then set the TIE, RIE, TE, and RE bits in SCR. Do not set the TE bit and RE bit at the same time, except for self-diagnosis.

Serial Data Transmission (Except Block Transfer Mode): As data transmission in smart card mode involves error signal sampling and retransmission processing, the processing procedure is different from that for the normal SCI. Figure 14-4 shows a flowchart for transmitting, and figure 14-5 shows the relation between a transmit operation and the internal registers.

- [1] Perform Smart Card interface mode initialization as described above in initialization.
- [2] Check that the ERS error flag in SSR is cleared to 0.
- [3] Repeat steps [2] and [3] until it can be confirmed that the TEND flag in SSR is set to 1.
- [4] Write the transmit data to TDR, clear the TDRE flag to 0, and perform the transmit operation.
The TEND flag is cleared to 0.
- [5] When transmitting data continuously, go back to step [2].
- [6] To end transmission, clear the TE bit to 0.

With the above processing, interrupt servicing or data transfer by the DTC is possible.

If transmission ends and the TEND flag is set to 1 while the TIE bit is set to 1 and interrupt requests are enabled, a transmit data empty interrupt (TXI) request will be generated. If an error occurs in transmission and the ERS flag is set to 1 while the RIE bit is set to 1 and interrupt requests are enabled, a transfer error interrupt (ERI) request will be generated.

The timing for setting the TEND flag depends on the value of the GM bit in SMR. The TEND flag set timing is shown in figure 14-6.

If the DTC* is activated by a TXI request, the number of bytes set in the DTC* can be transmitted automatically, including automatic retransmission.

For details, see Interrupt Operation and Data Transfer Operation by DTC below.

Notes: For block transfer mode, see section 13.3.2, Operation in Asynchronous Mode.

* The DTC is not implemented in the H8S/2635 and H8S/2634.

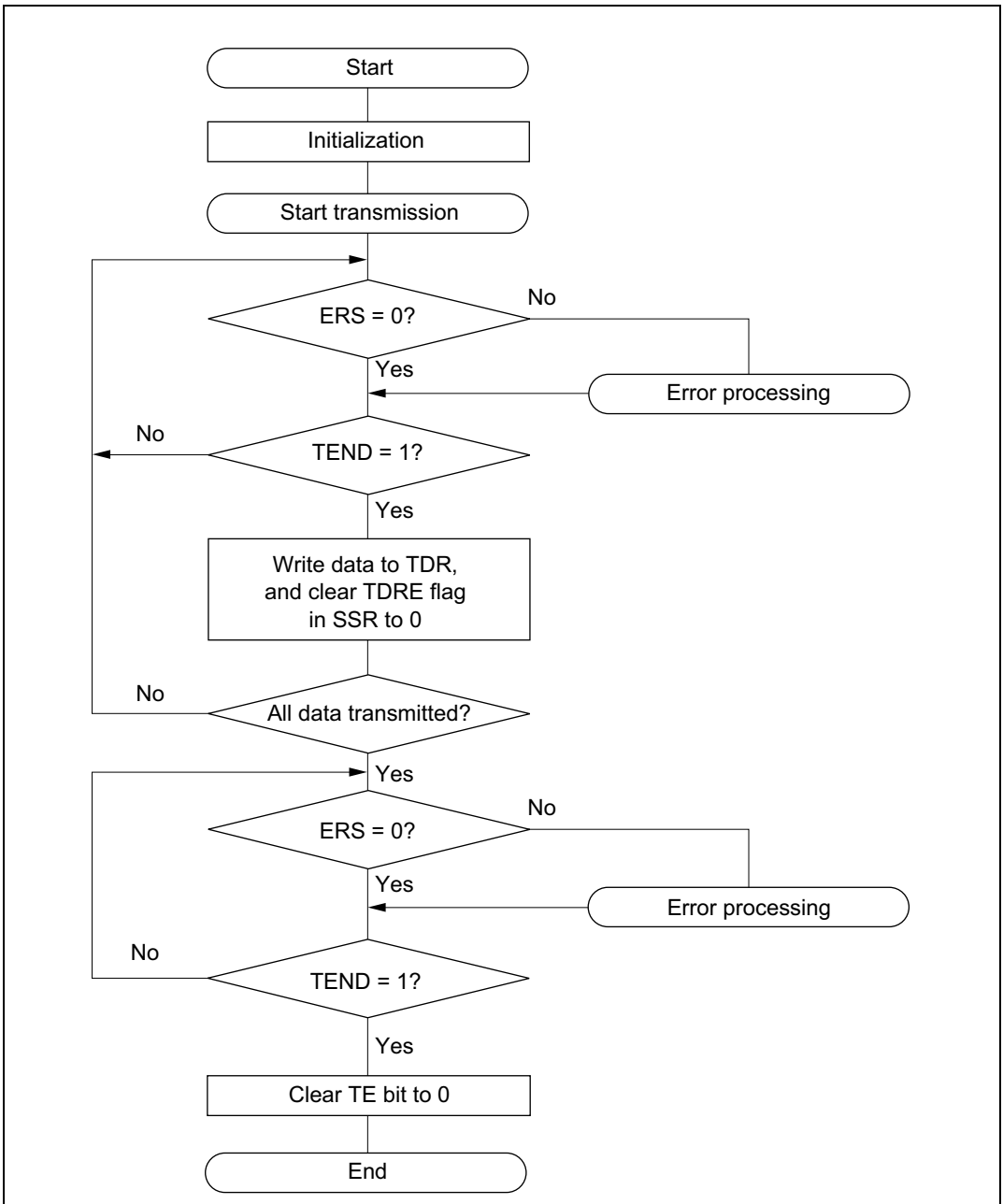

Figure 14-4 Example of Transmission Processing Flow

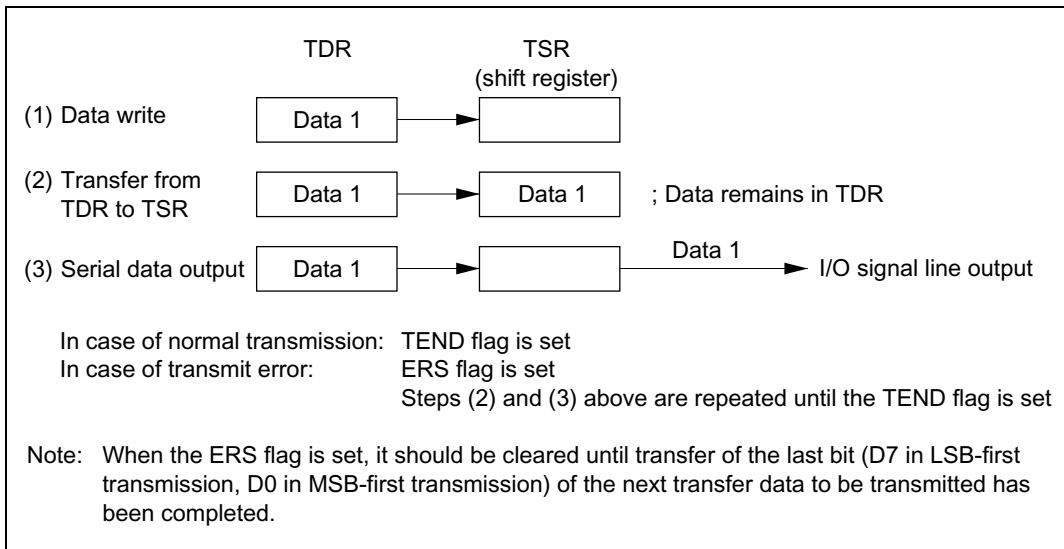

Figure 14-5 Relation Between Transmit Operation and Internal Registers

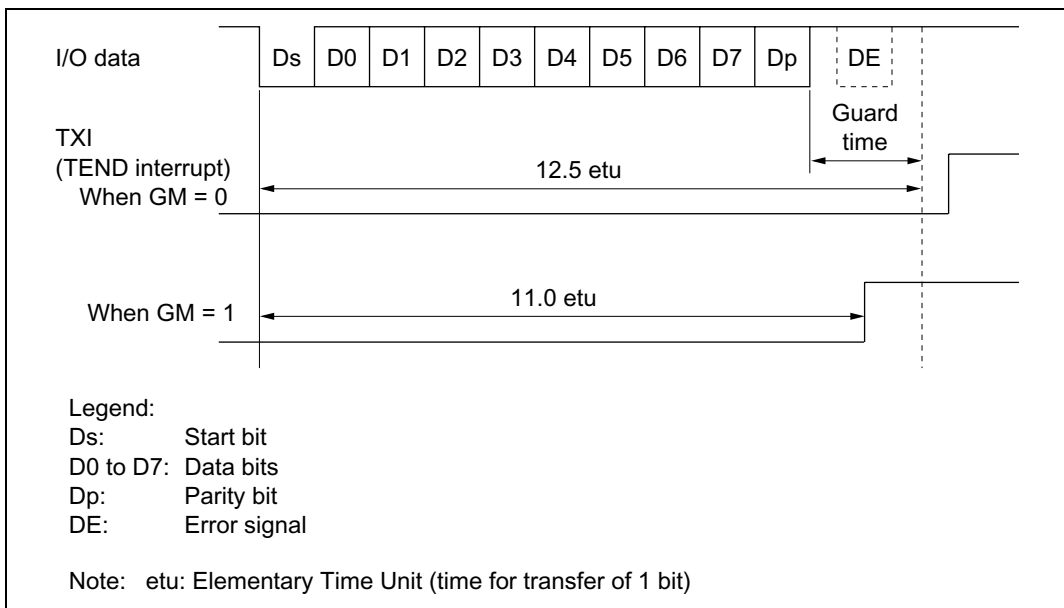

Figure 14-6 TEND Flag Generation Timing in Transmission Operation

Serial Data Reception (Except Block Transfer Mode): Data reception in Smart Card mode uses the same processing procedure as for the normal SCI. Figure 14-7 shows an example of the transmission processing flow.

- [1] Perform Smart Card interface mode initialization as described above in Initialization.
- [2] Check that the ORER flag and PER flag in SSR are cleared to 0. If either is set, perform the appropriate receive error processing, then clear both the ORER and the PER flag to 0.
- [3] Repeat steps [2] and [3] until it can be confirmed that the RDRF flag is set to 1.
- [4] Read the receive data from RDR.
- [5] When receiving data continuously, clear the RDRF flag to 0 and go back to step [2].
- [6] To end reception, clear the RE bit to 0.

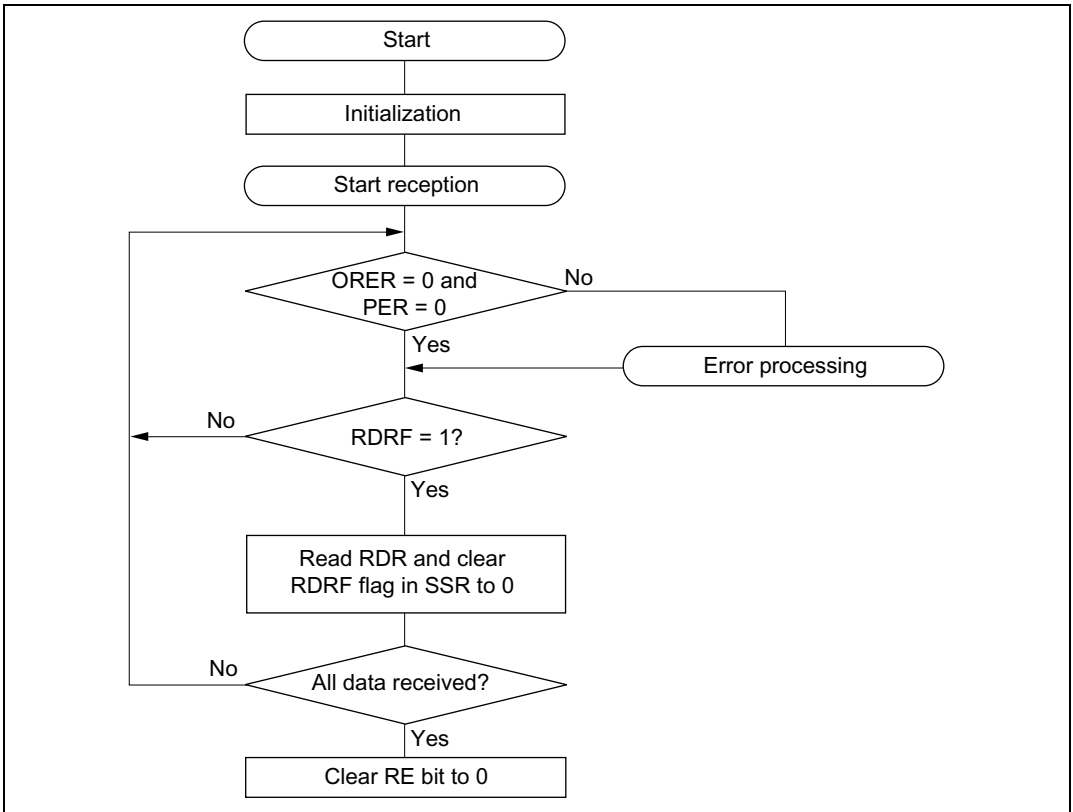

Figure 14-7 Example of Reception Processing Flow

With the above processing, interrupt servicing or data transfer by the DTC* is possible.

If reception ends and the RDRF flag is set to 1 while the RIE bit is set to 1 and interrupt requests are enabled, a receive data full interrupt (RXI) request will be generated. If an error occurs in reception and either the ORER flag or the PER flag is set to 1, a transfer error interrupt (ERI) request will be generated.

If the DTC* is activated by an RXI request, the receive data in which the error occurred is skipped, and only the number of bytes of receive data set in the DTC* are transferred.

For details, see Interrupt Operation and Data Transfer Operation by DTC* followings.

If a parity error occurs during reception and the PER is set to 1, the received data is still transferred to RDR, and therefore this data can be read.

Note: For block transfer mode, see section 13.3.2, Operation in Asynchronous Mode.

* The DTC is not implemented in the H8S/2635 and H8S/2634.

Mode Switching Operation: When switching from receive mode to transmit mode, first confirm that the receive operation has been completed, then start from initialization, clearing RE bit to 0 and setting TE bit to 1. The RDRF flag or the PER and ORER flags can be used to check that the receive operation has been completed.

When switching from transmit mode to receive mode, first confirm that the transmit operation has been completed, then start from initialization, clearing TE bit to 0 and setting RE bit to 1. The TEND flag can be used to check that the transmit operation has been completed.

Fixing Clock Output Level: When the GM bit in SMR is set to 1, the clock output level can be fixed with bits CKE1 and CKE0 in SCR. At this time, the minimum clock pulse width can be made the specified width.

Figure 14-8 shows the timing for fixing the clock output level. In this example, GSM is set to 1, CKE1 is cleared to 0, and the CKE0 bit is controlled.

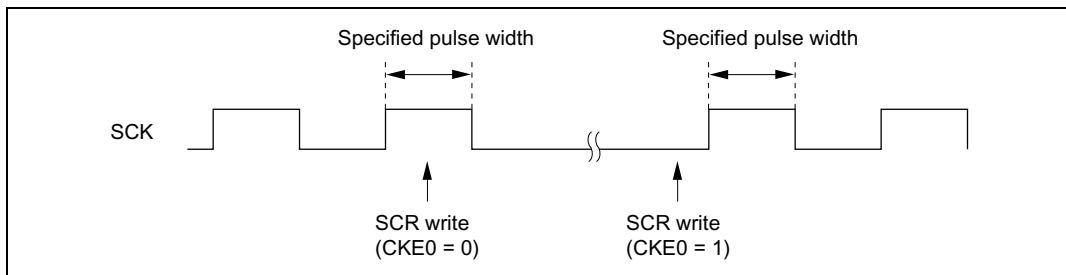

Figure 14-8 Timing for Fixing Clock Output Level

Interrupt Operation (Except Block Transfer Mode): There are three interrupt sources in smart card interface mode: transmit data empty interrupt (TXI) requests, transfer error interrupt (ERI) requests, and receive data full interrupt (RXI) requests. The transmit end interrupt (TEI) request is not used in this mode.

When the TEND flag in SSR is set to 1, a TXI interrupt request is generated.

When the RDRF flag in SSR is set to 1, an RXI interrupt request is generated.

When any of flags ORER, PER, and ERS in SSR is set to 1, an ERI interrupt request is generated. The relationship between the operating states and interrupt sources is shown in table 14-8.

Note: For block transfer mode, see section 13.4, SCI Interrupts.

Table 14-8 Smart Card Mode Operating States and Interrupt Sources

Operating State	Flag	Enable Bit	Interrupt Source	DTC Activation	
Transmit Mode	Normal operation	TEND	TIE	TXI	Possible
	Error	ERS	RIE	ERI	Not possible
Receive Mode	Normal operation	RDRF	RIE	RXI	Possible
	Error	PER, ORER	RIE	ERI	Not possible

Data Transfer Operation by DTC*: In smart card mode, as with the normal SCI, transfer can be carried out using the DTC. In a transmit operation, the TDRE flag is also set to 1 at the same time as the TEND flag in SSR, and a TXI interrupt is generated. If the TXI request is designated beforehand as a DTC activation source, the DTC will be activated by the TXI request, and transfer of the transmit data will be carried out. The TDRE and TEND flags are automatically cleared to 0 when data transfer is performed by the DTC. In the event of an error, the SCI retransmits the same data automatically. During this period, TEND remains cleared to 0 and the DTC is not activated. Therefore, the SCI and DTC will automatically transmit the specified number of bytes, including retransmission in the event of an error. However, the ERS flag is not cleared automatically when an error occurs, and so the RIE bit should be set to 1 beforehand so that an ERI request will be generated in the event of an error, and the ERS flag will be cleared.

When performing transfer using the DTC, it is essential to set and enable the DTC before carrying out SCI setting. For details of the DTC setting procedures, see section 8, Data Transfer Controller (DTC).

In a receive operation, an RXI interrupt request is generated when the RDRF flag in SSR is set to 1. If the RXI request is designated beforehand as a DTC activation source, the DTC will be activated by the RXI request, and transfer of the receive data will be carried out. The RDRF flag is cleared to 0 automatically when data transfer is performed by the DTC. If an error occurs, an error flag is set but the RDRF flag is not. Consequently, the DTC is not activated, but instead, an ERI interrupt request is sent to the CPU. Therefore, the error flag should be cleared.

Notes: For block transfer mode, see section 13.4, SCI Interrupts.

* The DTC is not implemented in the H8S/2635 and H8S/2634.

14.3.7 Operation in GSM Mode

Switching the Mode: When switching between smart card interface mode and software standby mode, the following switching procedure should be followed in order to maintain the clock duty.

- When changing from smart card interface mode to software standby mode
 - [1] Set the data register (DR) and data direction register (DDR) corresponding to the SCK pin to the value for the fixed output state in software standby mode.
 - [2] Write 0 to the TE bit and RE bit in the serial control register (SCR) to halt transmit/receive operation. At the same time, set the CKE1 bit to the value for the fixed output state in software standby mode.
 - [3] Write 0 to the CKE0 bit in SCR to halt the clock.
 - [4] Wait for one serial clock period.

During this interval, clock output is fixed at the specified level, with the duty preserved.
 - [5] Make the transition to the software standby state.
- When returning to smart card interface mode from software standby mode
 - [6] Exit the software standby state.
 - [7] Write 1 to the CKE0 bit in SCR and output the clock. Signal generation is started with the normal duty.

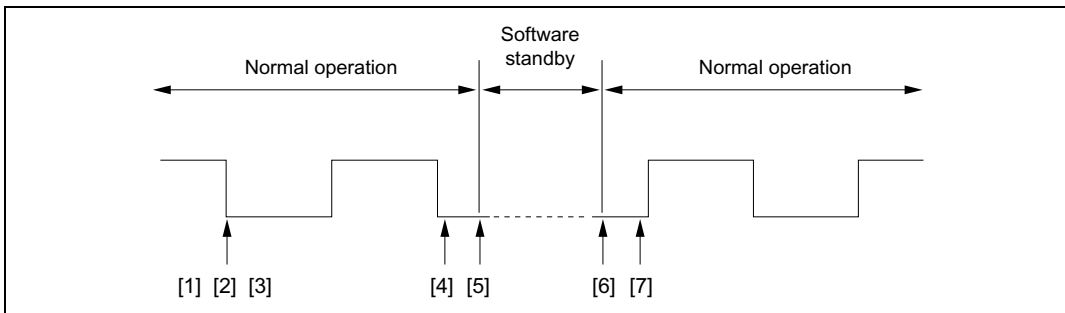

Figure 14-9 Clock Halt and Restart Procedure

Powering On: To secure the clock duty from power-on, the following switching procedure should be followed.

- [1] The initial state is port input and high impedance. Use a pull-up resistor or pull-down resistor to fix the potential.
- [2] Fix the SCK pin to the specified output level with the CKE1 bit in SCR.
- [3] Set SMR and SCMR, and switch to smart card mode operation.
- [4] Set the CKE0 bit in SCR to 1 to start clock output.

14.3.8 Operation in Block Transfer Mode

Operation in block transfer mode is the same as in SCI asynchronous mode, except for the following points. For details, see section 13.3.2, Operation in Asynchronous Mode.

Data Format: The data format is 8 bits with parity. There is no stop bit, but there is a 2-bit (1-bit or more in reception) error guard time.

Also, except during transmission (with start bit, data bits, and parity bit), the transmission pins go to the high-impedance state, so the signal lines must be fixed high with a pull-up resistor.

Transmit/Receive Clock: Only an internal clock generated by the on-chip baud rate generator can be used as the transmit/receive clock. The number of basic clock periods in a 1-bit transfer interval can be set to 32, 64, 372, or 256 with bits BCP1 and BCP0. For details, see section 14.3.5, Clock.

ERS (FER) Flag: As with the normal Smart Card interface, the ERS flag indicates the error signal status, but since error signal transmission and reception is not performed, this flag is always cleared to 0.

14.4 Usage Notes

The following points should be noted when using the SCI as a Smart Card interface.

Receive Data Sampling Timing and Reception Margin in Smart Card Interface Mode: In Smart Card interface mode, the SCI operates on a basic clock with a frequency of 32, 64, 372, or 256 times the transfer rate (as determined by bits BCP1 and BCP0).

In reception, the SCI samples the falling edge of the start bit using the basic clock, and performs internal synchronization. Receive data is latched internally at the rising edge of the 16th, 32nd, 186th, or 128th pulse of the basic clock. Figure 14-10 shows the receive data sampling timing when using a clock of 372 times the transfer rate.

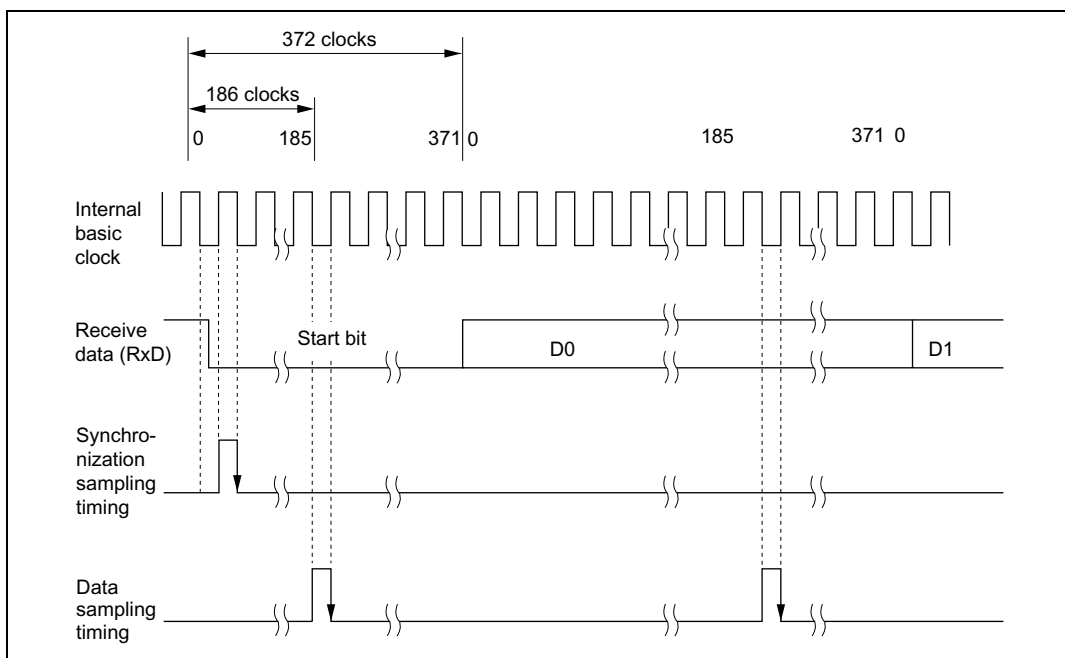

**Figure 14-10 Receive Data Sampling Timing in Smart Card Mode
(Using Clock of 372 Times the Transfer Rate)**

Thus the reception margin in asynchronous mode is given by the following formula.

Formula for reception margin in smart card interface mode

$$M = \left| \left(0.5 - \frac{1}{2N} \right) - (L - 0.5) F - \frac{|D - 0.5|}{N} (1 + F) \right| \times 100\%$$

Where M: Reception margin (%)

N: Ratio of bit rate to clock (N = 32, 64, 372, and 256)

D: Clock duty (D = 0 to 1.0)

L: Frame length (L = 10)

F: Absolute value of clock frequency deviation

Assuming values of F = 0, D = 0.5 and N = 372 in the above formula, the reception margin formula is as follows.

When D = 0.5 and F = 0,

$$\begin{aligned} M &= (0.5 - 1/2 \times 372) \times 100\% \\ &= 49.866\% \end{aligned}$$

Retransfer Operations (Except Block Transfer Mode): Retransfer operations are performed by the SCI in receive mode and transmit mode as described below.

- Retransfer operation when SCI is in receive mode

Figure 14-11 illustrates the retransfer operation when the SCI is in receive mode.

- [1] If an error is found when the received parity bit is checked, the PER bit in SSR is automatically set to 1. If the RIE bit in SCR is enabled at this time, an ERI interrupt request is generated. The PER bit in SSR should be kept cleared to 0 until the next parity bit is sampled.
- [2] The RDRF bit in SSR is not set for a frame in which an error has occurred.
- [3] If no error is found when the received parity bit is checked, the PER bit in SSR is not set to 1.
- [4] If no error is found when the received parity bit is checked, the receive operation is judged to have been completed normally, and the RDRF flag in SSR is automatically set to 1. If the RIE bit in SCR is enabled at this time, an RXI interrupt request is generated.
If DTC* data transfer by an RXI source is enabled, the contents of RDR can be read automatically. When the RDR data is read by the DTC*, the RDRF flag is automatically cleared to 0.
- [5] When a normal frame is received, the pin retains the high-impedance state at the timing for error signal transmission.

Note: * The DTC is not implemented in the H8S/2635 and H8S/2634.

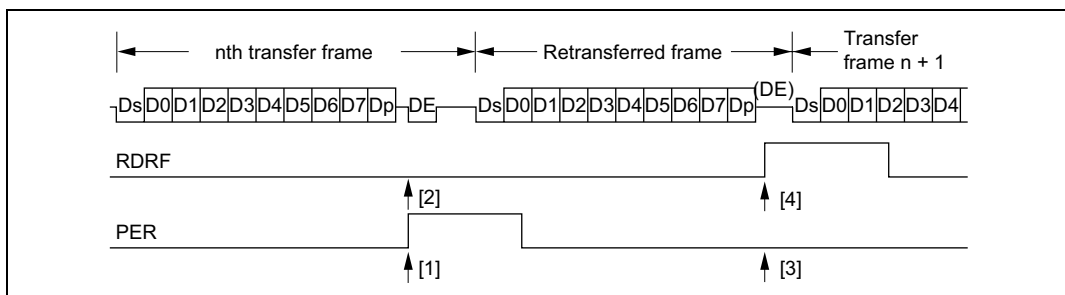

Figure 14-11 Retransfer Operation in SCI Receive Mode

- Retransfer operation when SCI is in transmit mode

Figure 14-12 illustrates the retransfer operation when the SCI is in transmit mode.

- [6] If an error signal is sent back from the receiving end after transmission of one frame is completed, the ERS bit in SSR is set to 1. If the RIE bit in SCR is enabled at this time, an ERI

interrupt request is generated. The ERS bit in SSR should be kept cleared to 0 until the next parity bit is sampled.

[7] The TEND bit in SSR is not set for a frame for which an error signal indicating an abnormality is received.

[8] If an error signal is not sent back from the receiving end, the ERS bit in SSR is not set.

[9] If an error signal is not sent back from the receiving end, transmission of one frame, including a retransfer, is judged to have been completed, and the TEND bit in SSR is set to 1. If the TIE bit in SCR is enabled at this time, a TXI interrupt request is generated.

If data transfer by the DTC* by means of the TXI source is enabled, the next data can be written to TDR automatically. When data is written to TDR by the DTC*, the TDRE bit is automatically cleared to 0.

Note: * The DTC is not implemented in the H8S/2635 and H8S/2634.

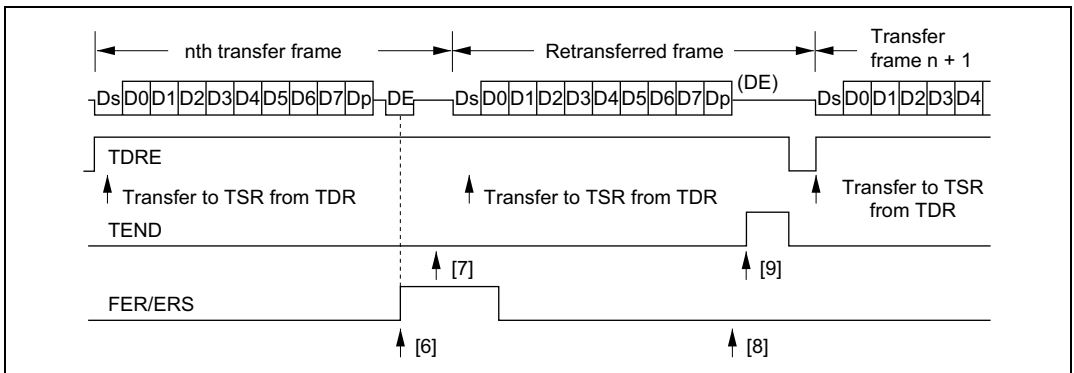

Figure 14-12 Retransfer Operation in SCI Transmit Mode

Section 15 I²C Bus Interface [Option] (Only for the H8S/2638, H8S/2639, and H8S/2630)

A two-channel I²C bus interface is available as an option in the H8S/2638, H8S/2639, and H8S/2630 (the product equipped with the I²C bus interface is the W-mask version). Observe the following notes when using this option.

A “W” is added to the part number in products in which this optional function is used.

Examples: HD64F2638WF*

Note: * When the optional function is used in a U-mask version, “U” is replaced with “W”.

Example: HD64F2638UF → HD64F2638WF

15.1 Overview

A two-channel I²C bus interface is available for the H8S/2638, H8S/2639, and H8S/2630 as an option. The I²C bus interface conforms to and provides a subset of the Philips I²C bus (inter-IC bus) interface functions. The register configuration that controls the I²C bus differs partly from the Philips configuration, however.

Each I²C bus interface channel uses only one data line (SDA) and one clock line (SCL) to transfer data, saving board and connector space.

15.1.1 Features

- Selection of addressing format or non-addressing format
 - I²C bus format: addressing format with acknowledge bit, for master/slave operation
 - Serial format: non-addressing format without acknowledge bit, for master operation only
- Conforms to Philips I²C bus interface (I²C bus format)
- Two ways of setting slave address (I²C bus format)
- Start and stop conditions generated automatically in master mode (I²C bus format)
- Selection of acknowledge output levels when receiving (I²C bus format)
- Automatic loading of acknowledge bit when transmitting (I²C bus format)
- Wait function in master mode (I²C bus format)
 - A wait can be inserted by driving the SCL pin low after data transfer, excluding acknowledgement. The wait can be cleared by clearing the interrupt flag.

- Wait function in slave mode (I²C bus format)
 - A wait request can be generated by driving the SCL pin low after data transfer, excluding acknowledgement. The wait request is cleared when the next transfer becomes possible.
- Three interrupt sources
 - Data transfer end (including transmission mode transition with I²C bus format and address reception after loss of master arbitration)
 - Address match: when any slave address matches or the general call address is received in slave receive mode (I²C bus format)
 - Stop condition detection
- Selection of 16 internal clocks (in master mode)
- Direct bus drive (with SCL and SDA pins)
 - Two pins—P35/SCL0 and P34/SDA0—(normally NMOS push-pull outputs) function as NMOS open-drain outputs when the bus drive function is selected.
 - Two pins—P33/SCL1 and P32/SDA1—(normally CMOS pins) function as NMOS-only outputs when the bus drive function is selected.

15.1.2 Block Diagram

Figure 15-1 shows a block diagram of the I²C bus interface.

Figure 15-2 shows an example of I/O pin connections to external circuits. Channel 0 I/O pins are NMOS open drains, and it is possible to apply voltages in excess of the power supply (V_{CC}) voltage for this LSI. Set the upper limit of voltage applied to the power supply (V_{CC}) power supply range + 0.3 V, i.e. 5.8 V. Channel 1 I/O pins are driven solely by NMOS, so in terms of appearance they carry out the same operations as an NMOS open drain. However, the voltage which can be applied to the I/O pins depends on the voltage of the power supply (V_{CC}) of this LSI.

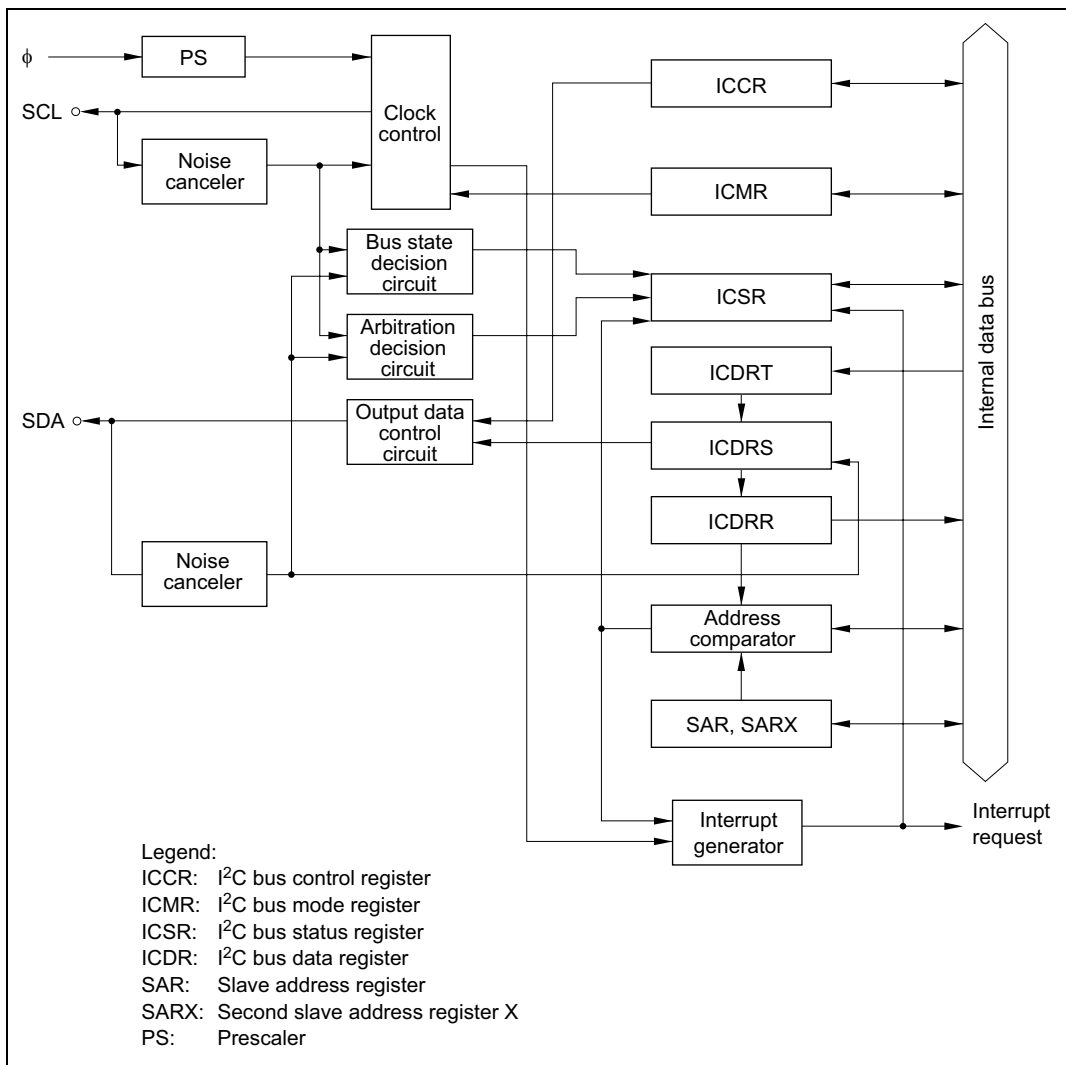
Figure 15-1 Block Diagram of I²C Bus Interface

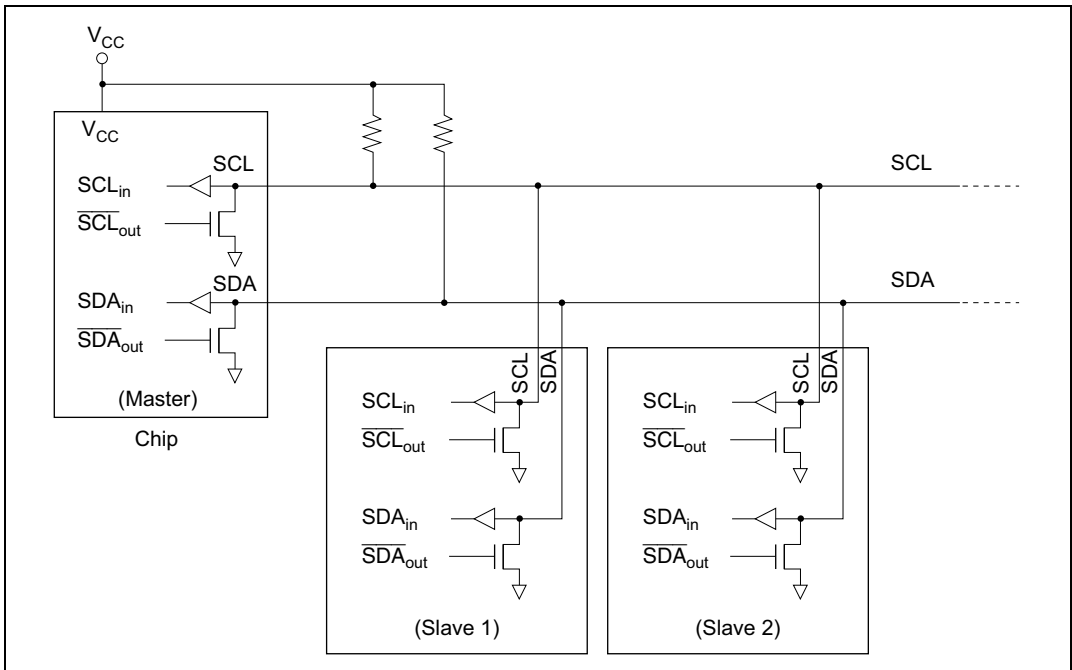

**Figure 15-2 I²C Bus Interface Connections
(Example: The Chip as Master)**

15.1.3 Input/Output Pins

Table 15-1 summarizes the input/output pins used by the I²C bus interface.

Table 15-1 I²C Bus Interface Pins

Channel	Name	Abbreviation	I/O	Function
0	Serial clock	SCL0	I/O	IIC0 serial clock input/output
	Serial data	SDA0	I/O	IIC0 serial data input/output
1	Serial clock	SCL1	I/O	IIC1 serial clock input/output
	Serial data	SDA1	I/O	IIC1 serial data input/output

Note: In the text, the channel subscript is omitted, and only SCL and SDA are used.

15.1.4 Register Configuration

Table 15-2 summarizes the registers of the I²C bus interface.

Table 15-2 Register Configuration

Channel	Name	Abbreviation	R/W	Initial Value	Address* ¹
0	I ² C bus control register	ICCR0	R/W	H'01	H'FF78* ³
	I ² C bus status register	ICSR0	R/W	H'00	H'FF79* ³
	I ² C bus data register	ICDR0	R/W	—	H'FF7E* ^{2*3}
	I ² C bus mode register	ICMR0	R/W	H'00	H'FF7F* ^{2*3}
	Slave address register	SAR0	R/W	H'00	H'FF7F* ^{2*3}
	Second slave address register	SARX0	R/W	H'01	H'FF7E* ^{2*3}
1	I ² C bus control register	ICCR1	R/W	H'01	H'FF80* ³
	I ² C bus status register	ICSR1	R/W	H'00	H'FF81* ³
	I ² C bus data register	ICDR1	R/W	—	H'FF86* ^{2*3}
	I ² C bus mode register	ICMR1	R/W	H'00	H'FF87* ^{2*3}
	Slave address register	SAR1	R/W	H'00	H'FF87* ^{2*3}
	Second slave address register	SARX1	R/W	H'01	H'FF86* ^{2*3}
Common	Serial control register X	SCRX	R/W	H'08	H'FDB4
	DDC switch register	DDCSWR	R/W	H'0F	H'FDB5
	Module stop control register B	MSTPCRB	R/W	H'FF	H'FDE9

Notes: 1. Lower 16 bits of the address.

2. The register that can be written or read depends on the ICE bit in the I²C bus control register. The slave address register can be accessed when ICE = 0, and the I²C bus mode register can be accessed when ICE = 1.
3. The I²C bus interface registers are assigned to the same addresses as other registers. Register selection is performed by means of the IICE bit in the serial control register X (SCRX).

15.2 Register Descriptions

15.2.1 I²C Bus Data Register (ICDR)

Bit	:	7	6	5	4	3	2	1	0
		ICDR7	ICDR6	ICDR5	ICDR4	ICDR3	ICDR2	ICDR1	ICDR0
Initial value	:	—	—	—	—	—	—	—	—
R/W	:	R/W	R/W	R/W	R/W	R/W	R/W	R/W	R/W

- ICDRR

Bit	:	7	6	5	4	3	2	1	0
		ICDRR7	ICDRR6	ICDRR5	ICDRR4	ICDRR3	ICDRR2	ICDRR1	ICDRR0
Initial value	:	—	—	—	—	—	—	—	—
R/W	:	R	R	R	R	R	R	R	R

- ICDRS

Bit	:	7	6	5	4	3	2	1	0
		ICDRS7	ICDRS6	ICDRS5	ICDRS4	ICDRS3	ICDRS2	ICDRS1	ICDRS0
Initial value	:	—	—	—	—	—	—	—	—
R/W	:	—	—	—	—	—	—	—	—

- ICDRT

Bit	:	7	6	5	4	3	2	1	0
		ICDRT7	ICDRT6	ICDRT5	ICDRT4	ICDRT3	ICDRT2	ICDRT1	ICDRT0
Initial value	:	—	—	—	—	—	—	—	—
R/W	:	W	W	W	W	W	W	W	W

- TDRE, RDRF (internal flags)

Bit	:	—	—
		TDRE	RDRF
Initial value	:	0	0
R/W	:	—	—

ICDR is an 8-bit readable/writable register that is used as a transmit data register when transmitting and a receive data register when receiving. ICDR is divided internally into a shift register (ICDRS), receive buffer (ICDRR), and transmit buffer (ICDRT). ICDRS cannot be read or written by the CPU, ICDRR is read-only, and ICDRT is write-only. Data transfers among the three registers are performed automatically in coordination with changes in the bus state, and affect the status of internal flags such as TDRE and RDRF.

If IIC is in transmit mode and the next data is in ICDRT (the TDRE flag is 0) following transmission/reception of one frame of data using ICDRS, data is transferred automatically from ICDRT to ICDRS. If IIC is in receive mode and no previous data remains in ICDRR (the RDRF flag is 0) following transmission/reception of one frame of data using ICDRS, data is transferred automatically from ICDRS to ICDRR.

If the number of bits in a frame, excluding the acknowledge bit, is less than 8, transmit data and receive data are stored differently. Transmit data should be written justified toward the MSB side when $MLS = 0$, and toward the LSB side when $MLS = 1$. Receive data bits read from the LSB side should be treated as valid when $MLS = 0$, and bits read from the MSB side when $MLS = 1$.

ICDR is assigned to the same address as SARX, and can be written and read only when the ICE bit is set to 1 in ICCR.

The value of ICDR is undefined after a reset.

The TDRE and RDRF flags are set and cleared under the conditions shown below. Setting the TDRE and RDRF flags affects the status of the interrupt flags.

TDRE	Description
0	The next transmit data is in ICDR (ICDRT), or transmission cannot be started (Initial value) [Clearing conditions] <ul style="list-style-type: none"> When transmit data is written in ICDR (ICDRT) in transmit mode (TRS = 1) When a stop condition is detected in the bus line state after a stop condition is issued with the I²C bus format or serial format selected When a stop condition is detected with the I²C bus format selected In receive mode (TRS = 0) (A 0 write to TRS during transfer is valid after reception of a frame containing an acknowledge bit)
1	The next transmit data can be written in ICDR (ICDRT) [Setting conditions] <ul style="list-style-type: none"> In transmit mode (TRS = 1), when a start condition is detected in the bus line state after a start condition is issued in master mode with the I²C bus format or serial format selected When data is transferred from ICDRT to ICDRS (Data transfer from ICDRT to ICDRS when TRS = 1 and TDRE = 0, and ICDRS is empty) In receive mode (TRS = 0), when a switch is made from slave receive mode (TRS = 0) to transmit mode (TRS = 1) after detection of a start condition (first time only)

RDRF	Description
0	The data in ICDR (ICDRR) is invalid (Initial value) [Clearing condition] <ul style="list-style-type: none"> When ICDR (ICDRR) receive data is read in receive mode
1	The ICDR (ICDRR) receive data can be read [Setting condition] <ul style="list-style-type: none"> When data is transferred from ICDRS to ICDRR (Data transfer from ICDRS to ICDRR in case of normal termination with TRS = 0 and RDRF = 0)

15.2.2 Slave Address Register (SAR)

Bit	:	7	6	5	4	3	2	1	0
		SVA6	SVA5	SVA4	SVA3	SVA2	SVA1	SVA0	FS
Initial value	:	0	0	0	0	0	0	0	0
R/W	:	R/W	R/W	R/W	R/W	R/W	R/W	R/W	R/W

SAR is an 8-bit readable/writable register that stores the slave address and selects the communication format. When the chip is in slave mode (and the addressing format is selected), if the upper 7 bits of SAR match the upper 7 bits of the first frame received after a start condition, the chip operates as the slave device specified by the master device. SAR is assigned to the same address as ICMR, and can be written and read only when the ICE bit is cleared to 0 in ICCR.

SAR is initialized to H'00 by a reset and in hardware standby mode.

Bits 7 to 1—Slave Address (SVA6 to SVA0): Set a unique address in bits SVA6 to SVA0, differing from the addresses of other slave devices connected to the I²C bus.

Bit 0—Format Select (FS): Used together with the FSX bit in SARX to select the communication format.

- I²C bus format: addressing format with acknowledge bit
- Synchronous serial format: non-addressing format without acknowledge bit, for master mode only

The FS bit also specifies whether or not SAR slave address recognition is performed in slave mode.

SAR Bit 0	SARX Bit 0	Operating Mode
0	0	I ² C bus format <ul style="list-style-type: none"> SAR and SARX slave addresses recognized
	1	I ² C bus format (Initial value) <ul style="list-style-type: none"> SAR slave address recognized SARX slave address ignored
1	0	I ² C bus format <ul style="list-style-type: none"> SAR slave address ignored SARX slave address recognized
	1	Synchronous serial format <ul style="list-style-type: none"> SAR and SARX slave addresses ignored

15.2.3 Second Slave Address Register (SARX)

Bit	:	7	6	5	4	3	2	1	0
		SVAX6	SVAX5	SVAX4	SVAX3	SVAX2	SVAX1	SVAX0	FSX
Initial value	:	0	0	0	0	0	0	0	1
R/W	:	R/W	R/W	R/W	R/W	R/W	R/W	R/W	R/W

SARX is an 8-bit readable/writable register that stores the second slave address and selects the communication format. When the chip is in slave mode (and the addressing format is selected), if the upper 7 bits of SARX match the upper 7 bits of the first frame received after a start condition, the chip operates as the slave device specified by the master device. SARX is assigned to the same address as ICDR, and can be written and read only when the ICE bit is cleared to 0 in ICCR.

SARX is initialized to H'01 by a reset and in hardware standby mode.

Bits 7 to 1—Second Slave Address (SVAX6 to SVAX0): Set a unique address in bits SVAX6 to SVAX0, differing from the addresses of other slave devices connected to the I²C bus.

Bit 0—Format Select X (FSX): Used together with the FS bit in SAR to select the communication format.

- I²C bus format: addressing format with acknowledge bit
- Synchronous serial format: non-addressing format without acknowledge bit, for master mode only

The FSX bit also specifies whether or not SARX slave address recognition is performed in slave mode. For details, see the description of the FS bit in SAR.

15.2.4 I²C Bus Mode Register (ICMR)

Bit	:	7	6	5	4	3	2	1	0
		MLS	WAIT	CKS2	CKS1	CKS0	BC2	BC1	BC0
Initial value	:	0	0	0	0	0	0	0	0
R/W	:	R/W	R/W	R/W	R/W	R/W	R/W	R/W	R/W

ICMR is an 8-bit readable/writable register that selects whether the MSB or LSB is transferred first, performs master mode wait control, and selects the master mode transfer clock frequency and the transfer bit count. ICMR is assigned to the same address as SAR. ICMR can be written and read only when the ICE bit is set to 1 in ICCR.

ICMR is initialized to H'00 by a reset and in hardware standby mode.

Bit 7—MSB-First/LSB-First Select (MLS): Selects whether data is transferred MSB-first or LSB-first.

If the number of bits in a frame, excluding the acknowledge bit, is less than 8, transmit data and receive data are stored differently. Transmit data should be written justified toward the MSB side when MLS = 0, and toward the LSB side when MLS = 1. Receive data bits read from the LSB side should be treated as valid when MLS = 0, and bits read from the MSB side when MLS = 1.

Do not set this bit to 1 when the I²C bus format is used.

Bit 7

MLS	Description
0	MSB-first (Initial value)
1	LSB-first

Bit 6—Wait Insertion Bit (WAIT): Selects whether to insert a wait between the transfer of data and the acknowledge bit, in master mode with the I²C bus format. When WAIT is set to 1, after the fall of the clock for the final data bit, the IRIC flag is set to 1 in ICCR, and a wait state begins (with SCL at the low level). When the IRIC flag is cleared to 0 in ICCR, the wait ends and the acknowledge bit is transferred. If WAIT is cleared to 0, data and acknowledge bits are transferred consecutively with no wait inserted.

The IRIC flag in ICCR is set to 1 on completion of the acknowledge bit transfer, regardless of the WAIT setting.

The setting of this bit is invalid in slave mode.

Bit 6

WAIT	Description	
0	Data and acknowledge bits transferred consecutively	(Initial value)
1	Wait inserted between data and acknowledge bits	

Bits 5 to 3—Serial Clock Select (CKS2 to CKS0): These bits, together with the IICX1 (channel 1) or IICX0 (channel 0) bit in the SCRX register, select the serial clock frequency in master mode. They should be set according to the required transfer rate.

SCRX

IICX	Bit 5 or 6	Bit 5	Bit 4	Bit 3	Clock	Transfer Rate				
						$\phi =$ 5 MHz	$\phi =$ 8 MHz	$\phi =$ 10 MHz	$\phi =$ 16 MHz	$\phi =$ 20 MHz
0	0	0	0	0	$\phi/28$	179 kHz	286 kHz	357 kHz	571 kHz*	714 kHz*
				1	$\phi/40$	125 kHz	200 kHz	250 kHz	400 kHz	500 kHz*
		1	0	$\phi/48$	104 kHz	167 kHz	208 kHz	333 kHz	417 kHz*	
			1	$\phi/64$	78.1 kHz	125 kHz	156 kHz	250 kHz	313 kHz	
	1	0	0	$\phi/80$	62.5 kHz	100 kHz	125 kHz	200 kHz	250 kHz	
			1	$\phi/100$	50.0 kHz	80.0 kHz	100 kHz	160 kHz	200 kHz	
		1	0	$\phi/112$	44.6 kHz	71.4 kHz	89.3 kHz	143 kHz	179 kHz	
			1	$\phi/128$	39.1 kHz	62.5 kHz	78.1 kHz	125 kHz	156 kHz	
1	0	0	0	$\phi/56$	89.3 kHz	143 kHz	179 kHz	286 kHz	357 kHz	
			1	$\phi/80$	62.5 kHz	100 kHz	125 kHz	200 kHz	250 kHz	
		1	0	$\phi/96$	52.1 kHz	83.3 kHz	104 kHz	167 kHz	208 kHz	
			1	$\phi/128$	39.1 kHz	62.5 kHz	78.1 kHz	125 kHz	156 kHz	
	1	0	0	$\phi/160$	31.3 kHz	50.0 kHz	62.5 kHz	100 kHz	125 kHz	
			1	$\phi/200$	25.0 kHz	40.0 kHz	50.0 kHz	80.0 kHz	100 kHz	
		1	0	$\phi/224$	22.3 kHz	35.7 kHz	44.6 kHz	71.4 kHz	89.3 kHz	
			1	$\phi/256$	19.5 kHz	31.3 kHz	39.1 kHz	62.5 kHz	78.1 kHz	

Note: * These rates are outside the ranges stipulated in the I²C bus interface specifications (normal mode: max. 100 kHz, high-speed mode: max. 400 kHz).

Bits 2 to 0—Bit Counter (BC2 to BC0): Bits BC2 to BC0 specify the number of bits to be transferred next. With the I²C bus format (when the FS bit in SAR or the FSX bit in SARX is 0), the data is transferred with one additional acknowledge bit. Bit BC2 to BC0 settings should be made during an interval between transfer frames. If bits BC2 to BC0 are set to a value other than 000, the setting should be made while the SCL line is low.

The bit counter is initialized to 000 by a reset and when a start condition is detected. The value returns to 000 at the end of a data transfer, including the acknowledge bit.

Bit 2 BC2	Bit 1 BC1	Bit 0 BC0	Bits/Frame		
			Synchronous Serial Format	I ² C Bus Format	
0	0	0	8	9	(Initial value)
		1	1	2	
	1	0	2	3	
		1	3	4	
1	0	0	4	5	
		1	5	6	
	1	0	6	7	
		1	7	8	

15.2.5 I²C Bus Control Register (ICCR)

Bit	:	7	6	5	4	3	2	1	0
		ICE	IEIC	MST	TRS	ACKE	BBSY	IRIC	SCP
Initial value	:	0	0	0	0	0	0	0	1
R/W	:	R/W	R/W	R/W	R/W	R/W	R/W	R/(W)*	W

Note: * Only 0 can be written, for flag clearing.

ICCR is an 8-bit readable/writable register that enables or disables the I²C bus interface, enables or disables interrupts, selects master or slave mode and transmission or reception, enables or disables acknowledgement, confirms the I²C bus interface bus status, issues start/stop conditions, and performs interrupt flag confirmation.

ICCR is initialized to H'01 by a reset and in hardware standby mode.

Bit 7—I²C Bus Interface Enable (ICE): Selects whether or not the I²C bus interface is to be used. When ICE is set to 1, port pins function as SCL and SDA input/output pins and transfer operations are enabled. When ICE is cleared to 0, the I²C bus interface module is halted and its internal states are cleared.

The SAR and SARX registers can be accessed when ICE is 0. The ICMR and ICDR registers can be accessed when ICE is 1.

Bit 7

ICE	Description
0	I ² C bus interface module disabled, with SCL and SDA signal pins set to port function (Initial value) I ² C bus interface module internal states initialized SAR and SARX can be accessed
1	I ² C bus interface module enabled for transfer operations (pins SCL and SCA are driving the bus) ICMR and ICDR can be accessed

Bit 6—I²C Bus Interface Interrupt Enable (IEIC): Enables or disables interrupts from the I²C bus interface to the CPU.

Bit 6

IEIC	Description
0	Interrupts disabled (Initial value)
1	Interrupts enabled

Bit 5—Master/Slave Select (MST)**Bit 4—Transmit/Receive Select (TRS)**

MST selects whether the I²C bus interface operates in master mode or slave mode.

TRS selects whether the I²C bus interface operates in transmit mode or receive mode.

In master mode with the I²C bus format, when arbitration is lost, MST and TRS are both reset by hardware, causing a transition to slave receive mode. In slave receive mode with the addressing format (FS = 0 or FSX = 0), hardware automatically selects transmit or receive mode according to the R/W bit in the first frame after a start condition.

Modification of the TRS bit during transfer is deferred until transfer of the frame containing the acknowledge bit is completed, and the changeover is made after completion of the transfer.

MST and TRS select the operating mode as follows.

Bit 5 MST	Bit 4 TRS	Operating Mode
0	0	Slave receive mode (Initial value)
	1	Slave transmit mode
1	0	Master receive mode
	1	Master transmit mode

Bit 5

MST	Description
0	Slave mode (Initial value) [Clearing conditions] (1) When 0 is written by software (2) When bus arbitration is lost after transmission is started in I ² C bus format master mode
1	Master mode [Setting conditions] (1) When 1 is written by software (in cases other than clearing condition (2)) (2) When 1 is written in MST after reading MST = 0 (in case of clearing condition (2))

Bit 4

TRS	Description
0	Receive mode (Initial value) [Clearing conditions] (1) When 0 is written by software (in cases other than setting condition (3)) (2) When 0 is written in TRS after reading TRS = 1 (in case of clearing condition (3)) (3) When bus arbitration is lost after transmission is started in I ² C bus format master mode
1	Transmit mode [Setting conditions] (1) When 1 is written by software (in cases other than clearing conditions (3) and 4) (2) When 1 is written in TRS after reading TRS = 0 (in case of clearing conditions (3) and 4) (3) When a 1 is received as the R/W bit of the first frame in I ² C bus format slave mode

Bit 3—Acknowledge Bit Judgement Selection (ACKE): Specifies whether the value of the acknowledge bit returned from the receiving device when using the I²C bus format is to be ignored and continuous transfer is performed, or transfer is to be aborted and error handling, etc., performed if the acknowledge bit is 1. When the ACKE bit is 0, the value of the received acknowledge bit is not indicated by the ACKB bit, which is always 0.

In this LSI, the DTC can be used to perform continuous transfer. The DTC is activated when the IRTR interrupt flag is set to 1 (IRTR is one of two interrupt flags, the other being IRIC). When the ACKE bit is 0, the TDRE, IRIC, and IRTR flags are set on completion of data transmission, regardless of the value of the acknowledge bit. When the ACKE bit is 1, the TDRE, IRIC, and IRTR flags are set on completion of data transmission when the acknowledge bit is 0, and the IRIC flag alone is set on completion of data transmission when the acknowledge bit is 1.

When the DTC is activated, the TDRE, IRIC, and IRTR flags are cleared to 0 after the specified number of data transfers have been executed. Consequently, interrupts are not generated during continuous data transfer, but if data transmission is completed with a 1 acknowledge bit when the ACKE bit is set to 1, the DTC is not activated and an interrupt is generated, if enabled.

Depending on the receiving device, the acknowledge bit may be significant, in indicating completion of processing of the received data, for instance, or may be fixed at 1 and have no significance.

Bit 3

ACKE	Description
0	The value of the acknowledge bit is ignored, and continuous transfer is performed (Initial value)
1	If the acknowledge bit is 1, continuous transfer is interrupted

Bit 2—Bus Busy (BBSY): The BBSY flag can be read to check whether the I²C bus (SCL, SDA) is busy or free. In master mode, this bit is also used to issue start and stop conditions.

A high-to-low transition of SDA while SCL is high is recognized as a start condition, setting BBSY to 1. A low-to-high transition of SDA while SCL is high is recognized as a stop condition, clearing BBSY to 0.

To issue a start condition, use a MOV instruction to write 1 in BBSY and 0 in SCP. A retransmit start condition is issued in the same way. To issue a stop condition, use a MOV instruction to write 0 in BBSY and 0 in SCP. It is not possible to write to BBSY in slave mode; the I²C bus interface must be set to master transmit mode before issuing a start condition. MST and TRS should both be set to 1 before writing 1 in BBSY and 0 in SCP.

Bit 2

BBSY	Description
0	Bus is free [Clearing condition] <ul style="list-style-type: none"> When a stop condition is detected
1	Bus is busy [Setting condition] <ul style="list-style-type: none"> When a start condition is detected

Bit 1—I²C Bus Interface Interrupt Request Flag (IRIC): Indicates that the I²C bus interface has issued an interrupt request to the CPU. IRIC is set to 1 at the end of a data transfer, when a slave address or general call address is detected in slave receive mode, when bus arbitration is lost in master transmit mode, and when a stop condition is detected. IRIC is set at different times depending on the FS bit in SAR and the WAIT bit in ICMR. See section 15.3.7, IRIC Setting Timing and SCL Control. The conditions under which IRIC is set also differ depending on the setting of the ACKC bit in ICCR.

IRIC is cleared by reading IRIC after it has been set to 1, then writing 0 in IRIC.

When the DTC is used, IRIC is cleared automatically and transfer can be performed continuously without CPU intervention.

Bit 1

IRIC	Description
0	<p>Waiting for transfer, or transfer in progress (Initial value)</p> <p>[Clearing conditions]</p> <ul style="list-style-type: none"> • When 0 is written in IRIC after reading IRIC = 1 • When ICDR is written or read by the DTC (When the TDRE or RDRF flag is cleared to 0) <p>(This is not always a clearing condition; see the description of DTC operation for details)</p>
1	<p>Interrupt requested</p> <p>[Setting conditions]</p> <p>I²C bus format master mode</p> <ul style="list-style-type: none"> • When a start condition is detected in the bus line state after a start condition is issued (when the TDRE flag is set to 1 because of first frame transmission) • When a wait is inserted between the data and acknowledge bit when WAIT = 1 • At the end of data transfer (at the rise of the 9th transmit/receive clock pulse, or at the fall of the 8th transmit/receive clock pulse when using wait insertion) • When a slave address is received after bus arbitration is lost (when the AL flag is set to 1) • When 1 is received as the acknowledge bit when the ACKE bit is 1 (when the ACKB bit is set to 1) <p>I²C bus format slave mode</p> <ul style="list-style-type: none"> • When the slave address (SVA, SVAX) matches (when the AAS and AASX flags are set to 1) • and at the end of data transfer up to the subsequent retransmission start condition or stop condition detection (when the TDRE or RDRF flag is set to 1) • When the general call address is detected (when FS = 0 and the ADZ flag is set to 1) and at the end of data transfer up to the subsequent retransmission start condition or stop condition detection (when the TDRE or RDRF flag is set to 1) • When 1 is received as the acknowledge bit when the ACKE bit is 1 (when the ACKB bit is set to 1) • When a stop condition is detected (when the STOP or ESTP flag is set to 1) <p>Synchronous serial format</p> <ul style="list-style-type: none"> • At the end of data transfer (when the TDRE or RDRF flag is set to 1) • When a start condition is detected with serial format selected <p>When any other condition arises in which the TDRE or RDRF flag is set to 1</p>

When, with the I²C bus format selected, IRIC is set to 1 and an interrupt is generated, other flags must be checked in order to identify the source that set IRIC to 1. Although each source has a corresponding flag, caution is needed at the end of a transfer.

When the TDRE or RDRF internal flag is set, the readable IRTR flag may or may not be set. The IRTR flag (the DTC start request flag) is not set at the end of a data transfer up to detection of a retransmission start condition or stop condition after a slave address (SVA) or general call address match in I²C bus format slave mode.

Even when the IRIC flag and IRTR flag are set, the TDRE or RDRF internal flag may not be set. The IRIC and IRTR flags are not cleared at the end of the specified number of transfers in continuous transfer using the DTC. The TDRE or RDRF flag is cleared, however, since the specified number of ICDR reads or writes have been completed.

Table 15-3 shows the relationship between the flags and the transfer states.

Table 15-3 Flags and Transfer States

MST	TRS	BBSY	ESTP	STOP	IRTR	AASX	AL	AAS	ADZ	ACKB	State
1/0	1/0	0	0	0	0	0	0	0	0	0	Idle state (flag clearing required)
1	1	0	0	0	0	0	0	0	0	0	Start condition issuance
1	1	1	0	0	1	0	0	0	0	0	Start condition established
1	1/0	1	0	0	0	0	0	0	0	0/1	Master mode wait
1	1/0	1	0	0	1	0	0	0	0	0/1	Master mode transmit/receive end
0	0	1	0	0	0	1/0	1	1/0	1/0	0	Arbitration lost
0	0	1	0	0	0	0	0	1	0	0	SAR match by first frame in slave mode
0	0	1	0	0	0	0	0	1	1	0	General call address match
0	0	1	0	0	0	1	0	0	0	0	SARX match
0	1/0	1	0	0	0	0	0	0	0	0/1	Slave mode transmit/receive end (except after SARX match)
0	1/0	1	0	0	1	1	0	0	0	0	Slave mode transmit/receive end (after SARX match)
0	1	1	0	0	0	1	0	0	0	1	Slave mode transmit/receive end (after SARX match)
0	1/0	0	1/0	1/0	0	0	0	0	0	0/1	Stop condition detected

Bit 0—Start Condition/Stop Condition Prohibit (SCP): Controls the issuing of start and stop conditions in master mode. To issue a start condition, write 1 in BBSY and 0 in SCP. A retransmit start condition is issued in the same way. To issue a stop condition, write 0 in BBSY and 0 in SCP. This bit is always read as 1. If 1 is written, the data is not stored.

Bit 0

SCP	Description
0	Writing 0 issues a start or stop condition, in combination with the BBSY flag
1	Reading always returns a value of 1 (Initial value) Writing is ignored

15.2.6 I²C Bus Status Register (ICSR)

Bit	:	7	6	5	4	3	2	1	0
		ESTP	STOP	IRTR	AASX	AL	AAS	ADZ	ACKB
Initial value	:	0	0	0	0	0	0	0	0
R/W	:	R/(W)*	R/(W)*	R/(W)*	R/(W)*	R/(W)*	R/(W)*	R/(W)*	R/W

Note: * Only 0 can be written, for flag clearing.

ICSR is an 8-bit readable/writable register that performs flag confirmation and acknowledge confirmation and control.

ICSR is initialized to H'00 by a reset and in hardware standby mode.

Bit 7—Error Stop Condition Detection Flag (ESTP): Indicates that a stop condition has been detected during frame transfer in I²C bus format slave mode.

Bit 7

ESTP	Description
0	No error stop condition [Clearing conditions] <ul style="list-style-type: none"> When 0 is written in ESTP after reading ESTP = 1 When the IRIC flag is cleared to 0
1	In I ² C bus format slave mode Error stop condition detected [Setting condition] <ul style="list-style-type: none"> When a stop condition is detected during frame transfer In other modes No meaning

Bit 6—Normal Stop Condition Detection Flag (STOP): Indicates that a stop condition has been detected after completion of frame transfer in I²C bus format slave mode.

Bit 6

STOP	Description
0	No normal stop condition [Clearing conditions] <ul style="list-style-type: none"> When 0 is written in STOP after reading STOP = 1 When the IRIC flag is cleared to 0
1	In I ² C bus format slave mode Normal stop condition detected [Setting condition] <ul style="list-style-type: none"> When a stop condition is detected after completion of frame transfer In other modes No meaning

Bit 5—I²C Bus Interface Continuous Transmission/Reception Interrupt Request Flag

(IRTR): Indicates that the I²C bus interface has issued an interrupt request to the CPU, and the source is completion of reception/transmission of one frame in continuous transmission/reception for which DTC activation is possible. When the IRTR flag is set to 1, the IRIC flag is also set to 1 at the same time.

IRTR flag setting is performed when the TDRE or RDRF flag is set to 1. IRTR is cleared by reading IRTR after it has been set to 1, then writing 0 in IRTR. IRTR is also cleared automatically when the IRIC flag is cleared to 0.

Bit 5

IRTR	Description
0	Waiting for transfer, or transfer in progress (Initial value) [Clearing conditions] <ul style="list-style-type: none"> When 0 is written in IRTR after reading IRTR = 1 When the IRIC flag is cleared to 0
1	Continuous transfer state [Setting conditions] <ul style="list-style-type: none"> In I²C bus interface slave mode When the TDRE or RDRF flag is set to 1 when AASX = 1 In other modes When the TDRE or RDRF flag is set to 1

Bit 4—Second Slave Address Recognition Flag (AASX): In I²C bus format slave receive mode, this flag is set to 1 if the first frame following a start condition matches bits SVAX6 to SVAX0 in SARX.

AASX is cleared by reading AASX after it has been set to 1, then writing 0 in AASX. AASX is also cleared automatically when a start condition is detected.

Bit 4

AASX	Description
0	Second slave address not recognized (Initial value) [Clearing conditions] <ul style="list-style-type: none"> When 0 is written in AASX after reading AASX = 1 When a start condition is detected In master mode
1	Second slave address recognized [Setting condition] <ul style="list-style-type: none"> When the second slave address is detected in slave receive mode and FSX = 0

Bit 3—Arbitration Lost (AL): This flag indicates that arbitration was lost in master mode. The I²C bus interface monitors the bus. When two or more master devices attempt to seize the bus at nearly the same time, if the I²C bus interface detects data differing from the data it sent, it sets AL to 1 to indicate that the bus has been taken by another master.

AL is cleared by reading AL after it has been set to 1, then writing 0 in AL. In addition, AL is reset automatically by write access to ICDR in transmit mode, or read access to ICDR in receive mode.

Bit 3

AL	Description
0	Bus arbitration won (Initial value) [Clearing conditions] <ul style="list-style-type: none"> • When ICDR data is written (transmit mode) or read (receive mode) • When 0 is written in AL after reading AL = 1
1	Arbitration lost [Setting conditions] <ul style="list-style-type: none"> • If the internal SDA and SDA pin disagree at the rise of SCL in master transmit mode • If the internal SCL line is high at the fall of SCL in master transmit mode

Bit 2—Slave Address Recognition Flag (AAS): In I²C bus format slave receive mode, this flag is set to 1 if the first frame following a start condition matches bits SVA6 to SVA0 in SAR, or if the general call address (H'00) is detected.

AAS is cleared by reading AAS after it has been set to 1, then writing 0 in AAS. In addition, AAS is reset automatically by write access to ICDR in transmit mode, or read access to ICDR in receive mode.

Bit 2

AAS	Description
0	Slave address or general call address not recognized (Initial value) [Clearing conditions] <ul style="list-style-type: none"> • When ICDR data is written (transmit mode) or read (receive mode) • When 0 is written in AAS after reading AAS = 1 • In master mode
1	Slave address or general call address recognized [Setting condition] <ul style="list-style-type: none"> • When the slave address or general call address is detected in slave receive mode and FS = 0

Bit 1—General Call Address Recognition Flag (ADZ): In I²C bus format slave receive mode, this flag is set to 1 if the first frame following a start condition is the general call address (H'00).

ADZ is cleared by reading ADZ after it has been set to 1, then writing 0 in ADZ. In addition, ADZ is reset automatically by write access to ICDR in transmit mode, or read access to ICDR in receive mode.

Bit 1

ADZ	Description
0	General call address not recognized (Initial value) [Clearing conditions] <ul style="list-style-type: none"> • When ICDR data is written (transmit mode) or read (receive mode) • When 0 is written in ADZ after reading ADZ = 1 • In master mode
1	General call address recognized [Setting condition] <ul style="list-style-type: none"> • When the general call address is detected in slave receive mode and (FSX = 0 or FS = 0)

Bit 0—Acknowledge Bit (ACKB): Stores acknowledge data. In transmit mode, after the receiving device receives data, it returns acknowledge data, and this data is loaded into ACKB. In receive mode, after data has been received, the acknowledge data set in this bit is sent to the transmitting device.

When this bit is read, in transmission (when TRS = 1), the value loaded from the bus line (returned by the receiving device) is read. In reception (when TRS = 0), the value set by internal software is read.

In addition, when this bit is written to in reception the transmission acknowledge data setting is overwritten regardless of the value of TRS. The value loaded from the reception device is maintained unchanged, so caution is necessary when using bit operation instructions to overwrite this register.

Bit 0

ACKB	Description
0	Receive mode: 0 is output at acknowledge output timing (Initial value) Transmit mode: Indicates that the receiving device has acknowledged the data (signal is 0)
1	Receive mode: 1 is output at acknowledge output timing Transmit mode: Indicates that the receiving device has not acknowledged the data (signal is 1)

15.2.7 Serial Control Register X (SCRX)

Bit	:	7	6	5	4	3	2	1	0
		—	IICX1	IICX0	IICE	—	—	—	—
Initial value	:	0	0	0	0	1	0	0	0
R/W	:	R/W	R/W	R/W	R/W	R	R/W	R/W	R/W

SCRX is an 8-bit readable/writable register that controls register access, the I²C interface operating mode. If a module controlled by SCRX is not used, do not write 1 to the corresponding bit.

SCRX is initialized to H'08 by a reset and in hardware standby mode.

Bit 7—Reserved: Do not set 1.

Bit 6—I²C Transfer Select 1 (IICX1): This bit, together with bits CKS2 to CKS0 in ICMR of IIC1, selects the transfer rate in master mode. For details, see section 15.2.4, I²C Bus Mode Register (ICMR).

Bit 5—I²C Transfer Select 0 (IICX0): This bit, together with bits CKS2 to CKS0 in ICMR of IIC0, selects the transfer rate in master mode. For details, see section 15.2.4, I²C Bus Mode Register (ICMR).

Bit 4—I²C Master Enable (IICE): Controls CPU access to the I²C bus interface data and control registers (ICCR, ICSR, ICDR/SARX, ICMR/SAR).

Bit 4

IICE	Description
0	CPU access to I ² C bus interface data and control registers is disabled (Initial value)
1	CPU access to I ² C bus interface data and control registers is enabled

Bit 3—Reserved: Always returns a value of 1 if it is read.

Bits 2 to 0—Reserved: Do not set 1.

15.2.8 DDC Switch Register (DDCSWR)

Bit	:	7	6	5	4	3	2	1	0
		—	—	—	—	CLR3	CLR2	CLR1	CLR0
Initial value	:	0	0	0	0	1	1	1	1
R/W	:	R/(W)*1	R/(W)*1	R/(W)*1	R/(W)*1	W*2	W*2	W*2	W*2

- Notes: 1. Should always be written with 0.
2. Always read as 1.

DDCSWR is an 8-bit readable/writable register that is used to initialize the IIC module.

DDCSWR is initialized to H'0F by a reset and in hardware standby mode.

Bits 7 to 4—Reserved: Should always be written with 0.

Bits 3 to 0—IIC Clear 3 to 0 (CLR3 to CLR0): These bits control initialization of the internal state of IIC0 and IIC1.

These bits can only be written to; if read they will always return a value of 1.

When a write operation is performed on these bits, a clear signal is generated for the internal latch circuit of the corresponding module(s), and the internal state of the IIC module(s) is initialized.

The write data for these bits is not retained. To perform IIC clearance, bits CLR3 to CLR0 must be written to simultaneously using an MOV instruction. Do not use a bit manipulation instruction such as BCLR.

When clearing is required again, all the bits must be written to in accordance with the setting.

Bit 3	Bit 2	Bit 1	Bit 0	Description
CLR3	CLR2	CLR1	CLR0	
0	0	—	—	Setting prohibited
			1	Setting prohibited
	1	0	0	IIC0 internal latch cleared
			1	IIC1 internal latch cleared
1	—	—	0	IIC0 and IIC1 internal latches cleared
			1	IIC0 and IIC1 internal latches cleared
1	—	—	—	Invalid setting

15.2.9 Module Stop Control Register B (MSTPCRB)

Bit	:	7	6	5	4	3	2	1	0
		MSTPB7	MSTPB6	MSTPB5	MSTPB4	MSTPB3	MSTPB2	MSTPB1	MSTPB0
Initial value	:	1	1	1	1	1	1	1	1
R/W	:	R/W	R/W	R/W	R/W	R/W	R/W	R/W	R/W

MSTPCRB is an 8-bit readable/writable register that perform module stop mode control.

When the MSTPB4 or MSTPB3 bit is set to 1, operation of the corresponding IIC channel is halted at the end of the bus cycle, and a transition is made to module stop mode. For details, see section 23A.5, 23B.5, Module Stop Mode.

MSTPCRB is initialized to H'FF by a power-on reset and in hardware standby mode. It is not initialized by a manual reset and in software standby mode.

Bit 4—Module Stop (MSTPB4): Specifies IIC channel 0 module stop mode.

Bit 4**MSTPB4 Description**

0	IIC channel 0 module stop mode is cleared	
1	IIC channel 0 module stop mode is set	(Initial value)

Bit 3—Module Stop (MSTPB3): Specifies IIC channel 1 module stop mode.

Bit 3**MSTPB3 Description**

0	IIC channel 1 module stop mode is cleared	
1	IIC channel 1 module stop mode is set	(Initial value)

15.3 Operation

15.3.1 I²C Bus Data Format

The I²C bus interface has serial and I²C bus formats.

The I²C bus formats are addressing formats with an acknowledge bit. These are shown in figures 15-3 (a) and (b). The first frame following a start condition always consists of 8 bits.

The serial format is a non-addressing format with no acknowledge bit. Although start and stop conditions must be issued, this format can be used as a synchronous serial format. This is shown in figure 15-4.

Figure 15-5 shows the I²C bus timing.

The symbols used in figures 15-3 to 15-5 are explained in table 15-4.

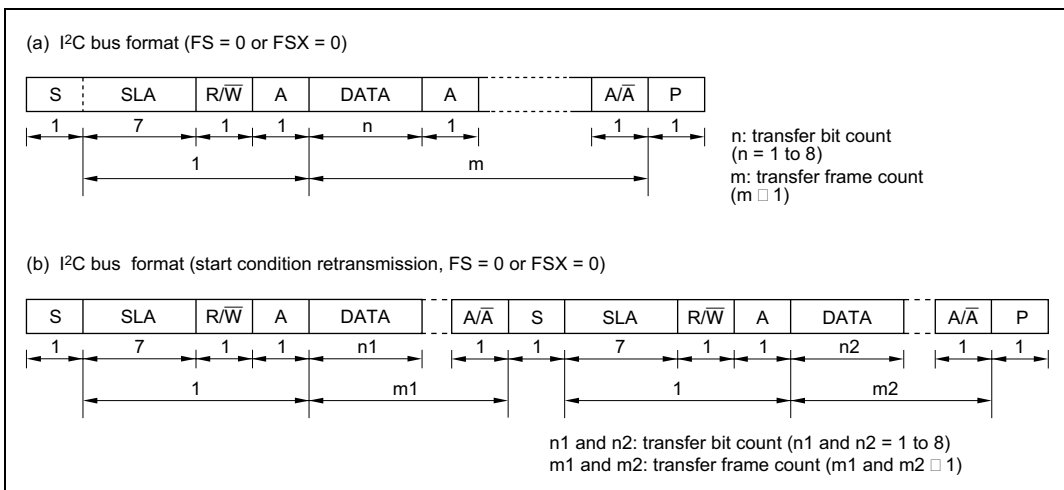
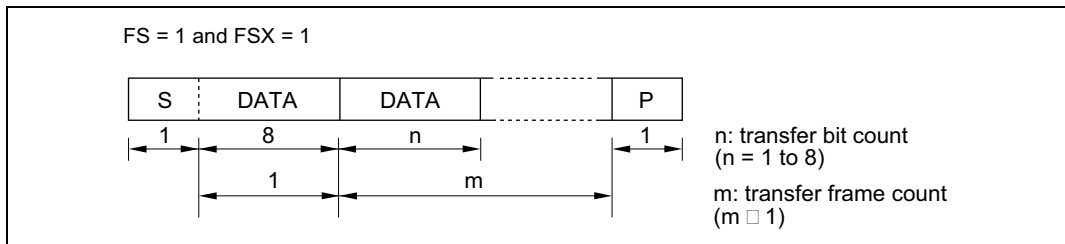
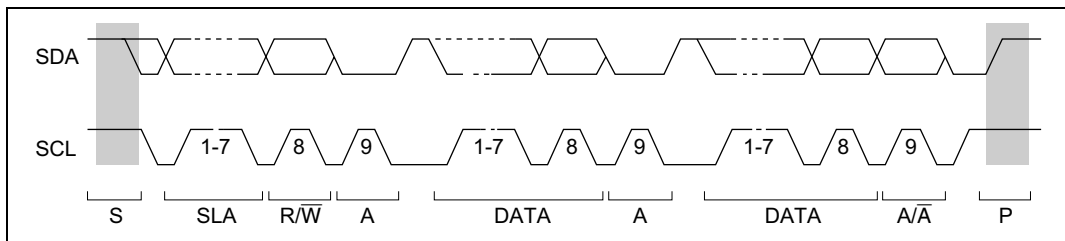

Figure 15-3 I²C Bus Data Formats (I²C Bus Formats)

Figure 15-4 I²C Bus Data Format (Serial Format)Figure 15-5 I²C Bus TimingTable 15-4 I²C Bus Data Format Symbols

Legend

S	Start condition. The master device drives SDA from high to low while SCL is high
SLA	Slave address, by which the master device selects a slave device
R/ \bar{W}	Indicates the direction of data transfer: from the slave device to the master device when R/ \bar{W} is 1, or from the master device to the slave device when R/ \bar{W} is 0
A	Acknowledge. The receiving device (the slave in master transmit mode, or the master in master receive mode) drives SDA low to acknowledge a transfer
DATA	Transferred data. The bit length is set by bits BC2 to BC0 in ICMR. The MSB-first or LSB-first format is selected by bit MLS in ICMR
P	Stop condition. The master device drives SDA from low to high while SCL is high

15.3.2 Initial Setting

At startup the following procedure is used to initialize the IIC.

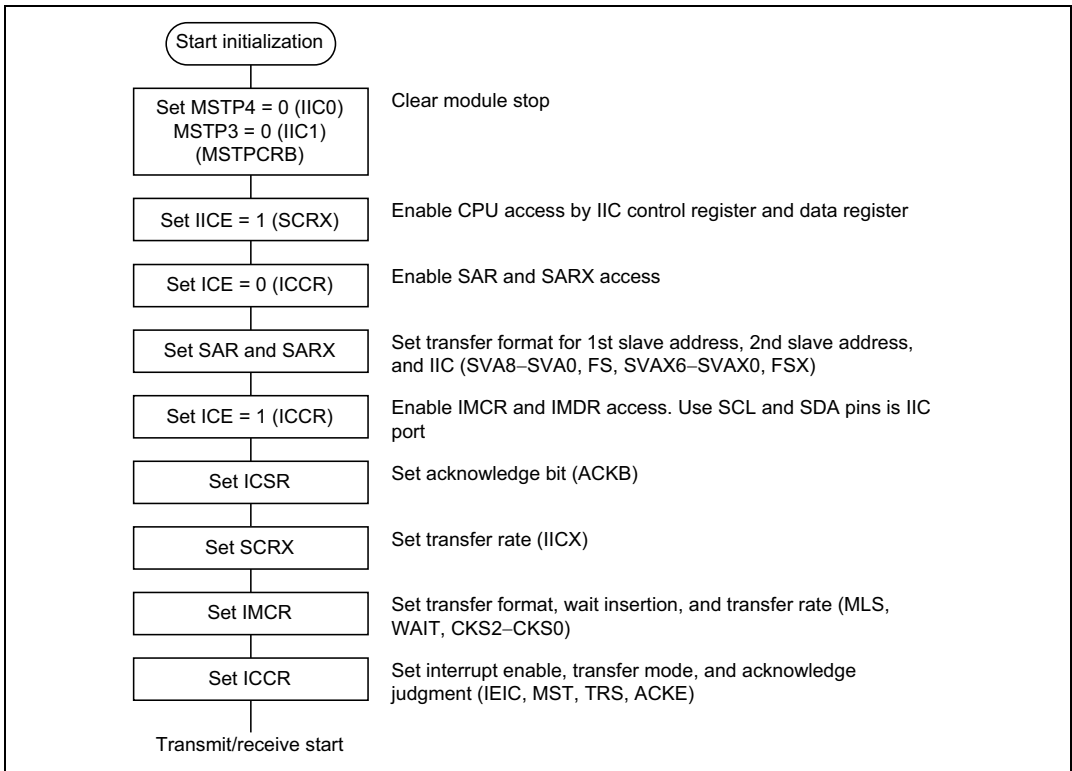

Figure 15-6 Flowchart for IIC Initialization (Example)

Note: The ICMR register should be written to only after transmit or receive operations have completed.

Writing to the ICMR register while a transmit or receive operation is in progress could cause an erroneous value to be written to bit counter bits BC2 to BC0. This could result in improper operation.

15.3.3 Master Transmit Operation

In I²C bus format master transmit mode, the master device outputs the transmit clock and transmit data, and the slave device returns an acknowledge signal.

Figure 15-7 is a flowchart showing an example of the master transmit mode.

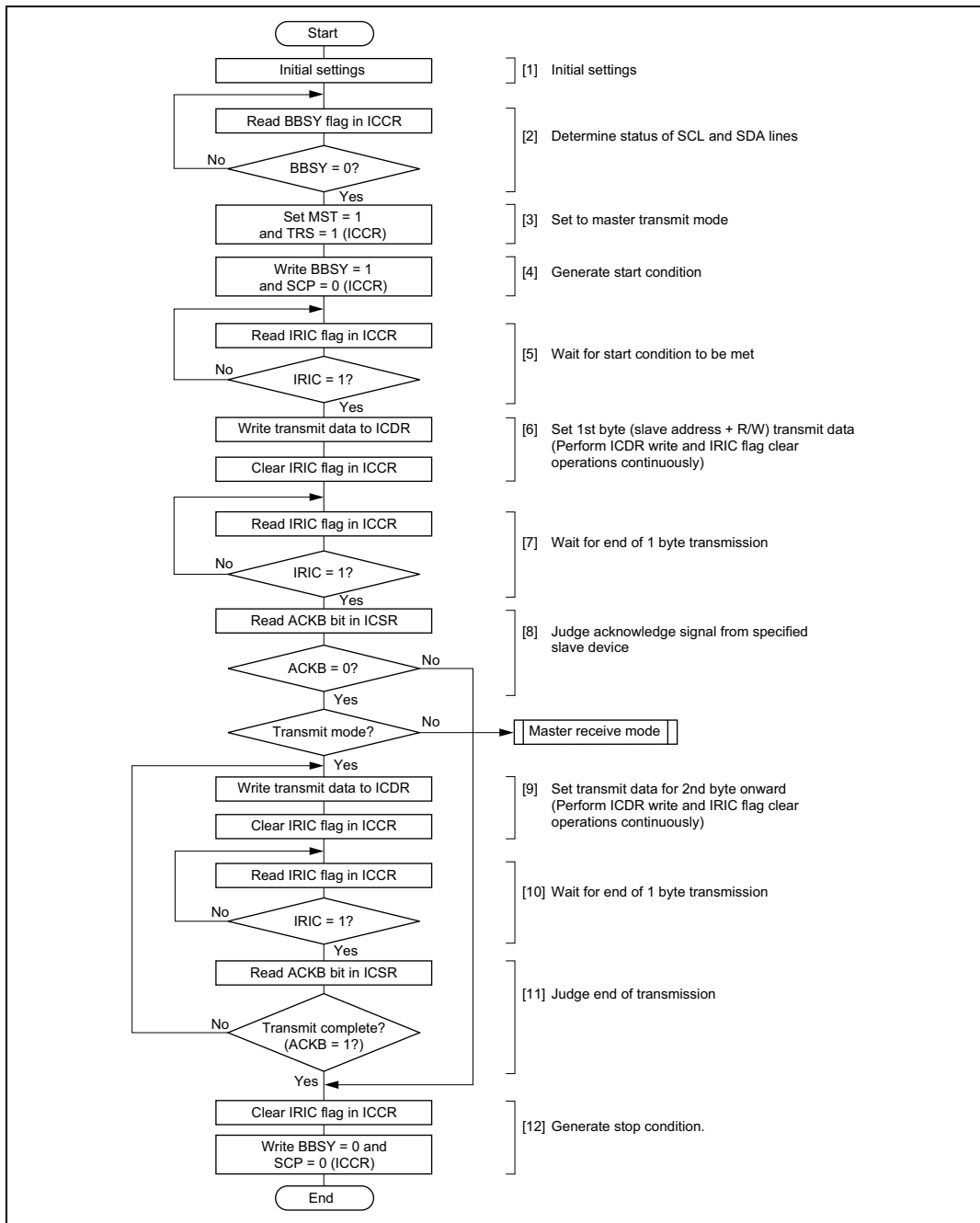

Figure 15-7 Flowchart for Master Transmit Mode (Example)

The procedure for transmitting data sequentially, synchronized with ICDR (ICDRT) write operations, is described below.

- [1] Perform initial settings as described in section 15.3.2, Initial Setting.
- [2] Read the BBSY flag in ICCR to confirm that the bus is free.
- [3] Set bits MST and TSR in ICCR to 1 to switch to the master transmit mode.
- [4] Write 1 to BBSY and 0 to SCP in ICCR. This changes SDA from high to low when SCL is high, and generates the start condition.
- [5] The IRIC and IRTR flags are set to 1 when the start condition is generated. If the IEIC bit in ICCR has been set to 1, an interrupt request is sent to the CPU.
- [6] After the start condition is detected, write the data (slave address + R/ \overline{W}) to ICDR. With the I²C bus format (when the FS bit in SAR or the FSX bit in SARX is 0), the first frame data following the start condition indicates the 7-bit slave address and transmit/receive direction (R/W). Next, clear the IRIC flag to 0 to indicate the end of the transfer. Continue successively writing to ICDR and clearing the IRIC flag to ensure that processing of other interrupts does not intervene. If the time required to transmit one byte of data elapses by the time the IRIC flag is cleared, it will not be possible to determine the end of the transmission. The master device sequentially sends the transmit clock and the data written to ICDR. The selected slave device (i.e., the slave device with the matching slave address) drives SDA low at the 9th transmit clock pulse and returns an acknowledge signal.
- [7] When one frame of data has been transmitted, the IRIC flag is set to 1 at the rise of the 9th transmit clock pulse. After one frame has been transmitted, SCL is automatically fixed low in synchronization with the internal clock until the next transmit data is written.
- [8] Read the ACKB bit in ICSR to confirm that its value is 0. If the slave device has not returned an acknowledge signal and the value of ACKB is 1, perform the transmit end processing described in step [12] and then recommence the transmit operation from the beginning.
- [9] Write the transmit data to ICDR. Next, clear the IRIC flag to 0 to indicate the end of the transfer. Then continue successively writing to ICDR and clearing the IRIC flag as described in step [6]. Transmission of the next frame is synchronized with the internal clock.
- [10] When one frame of data has been transmitted, the IRIC flag is set to 1 at the rise of the 9th transmit clock pulse. After one frame has been transmitted, SCL is automatically fixed low in synchronization with the internal clock until the next transmit data is written.
- [11] Read the ACKB bit in ICSR to confirm that the slave device has returned an acknowledge signal and the value of ACKB is 0. If the slave device has not returned an acknowledge signal and the value of ACKB is 1, perform the transmit end processing described in step [12].
- [12] Clear the IRIC flag to 0. Write 0 to the ACKE bit in ICCR and clear the received ACKB bit to 0.

Write 0 to BBSY and SCP in ICCR. This changes SDA from low to high when SCL is high, and generates the stop condition.

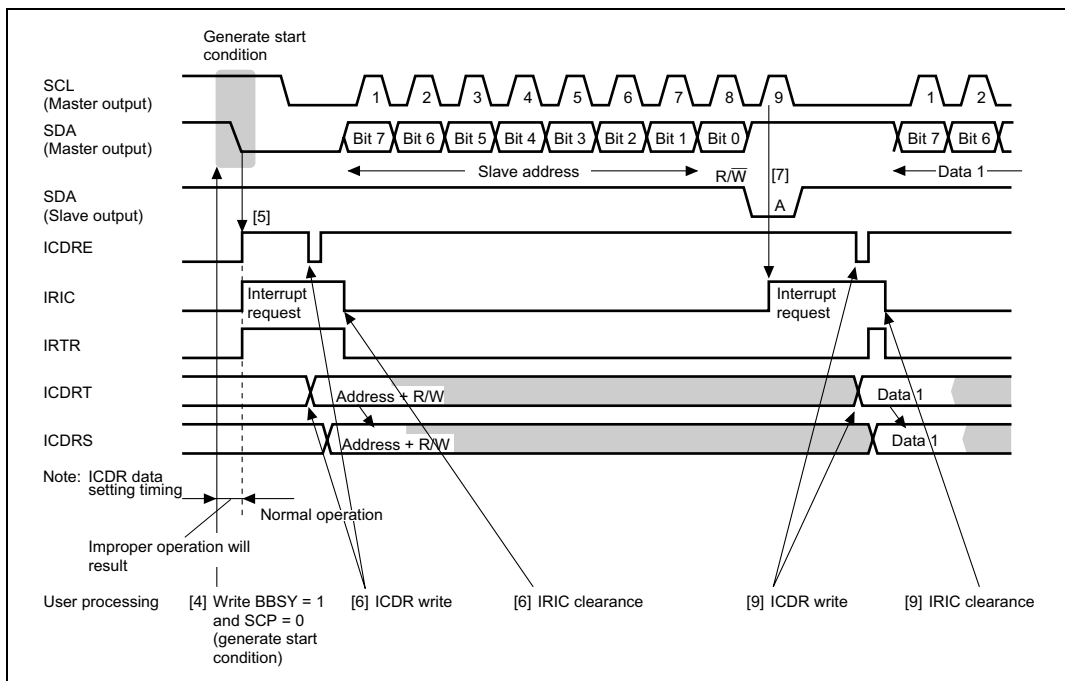

Figure 15-8 Example of Master Transmit Mode Operation Timing (MLS = WAIT = 0)

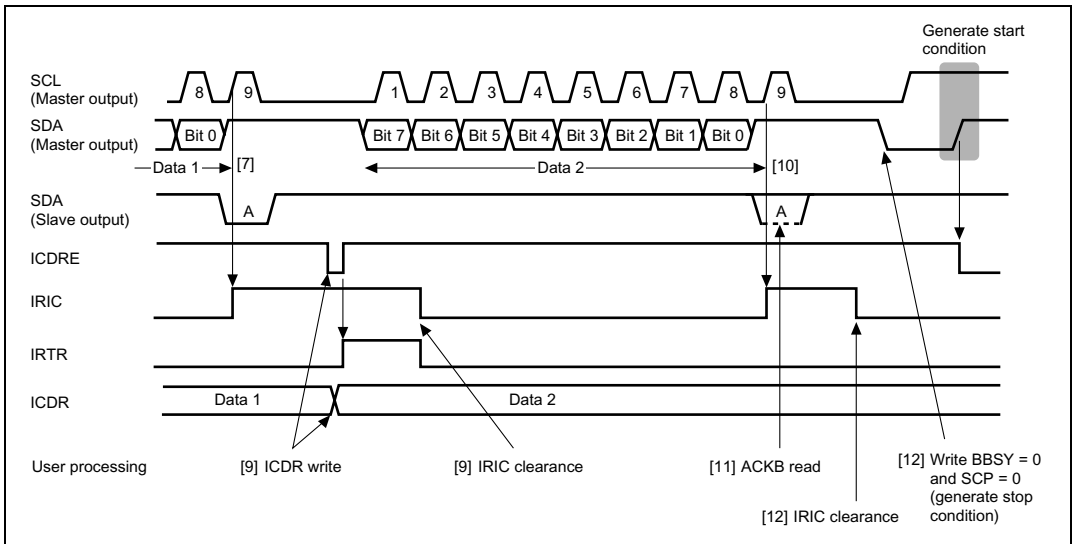

Figure 15-9 Example of Master Transmit Mode Stop Condition Generation Timing (MLS = WAIT = 0)

15.3.4 Master Receive Operation

In I²C bus format master receive mode, the master device outputs the receive clock, receives data, and returns an acknowledge signal. The slave device transmits data.

The master device transmits the data containing the slave address + R/W (0: read) in the 1st frame after a start condition is generated in the master transmit mode. After the slave device is selected the switch to receive operation takes place.

(1) Receive Operation Using Wait States

Figures 15-10 and 15-11 are flowcharts showing examples of the master receive mode (WAIT = 1).

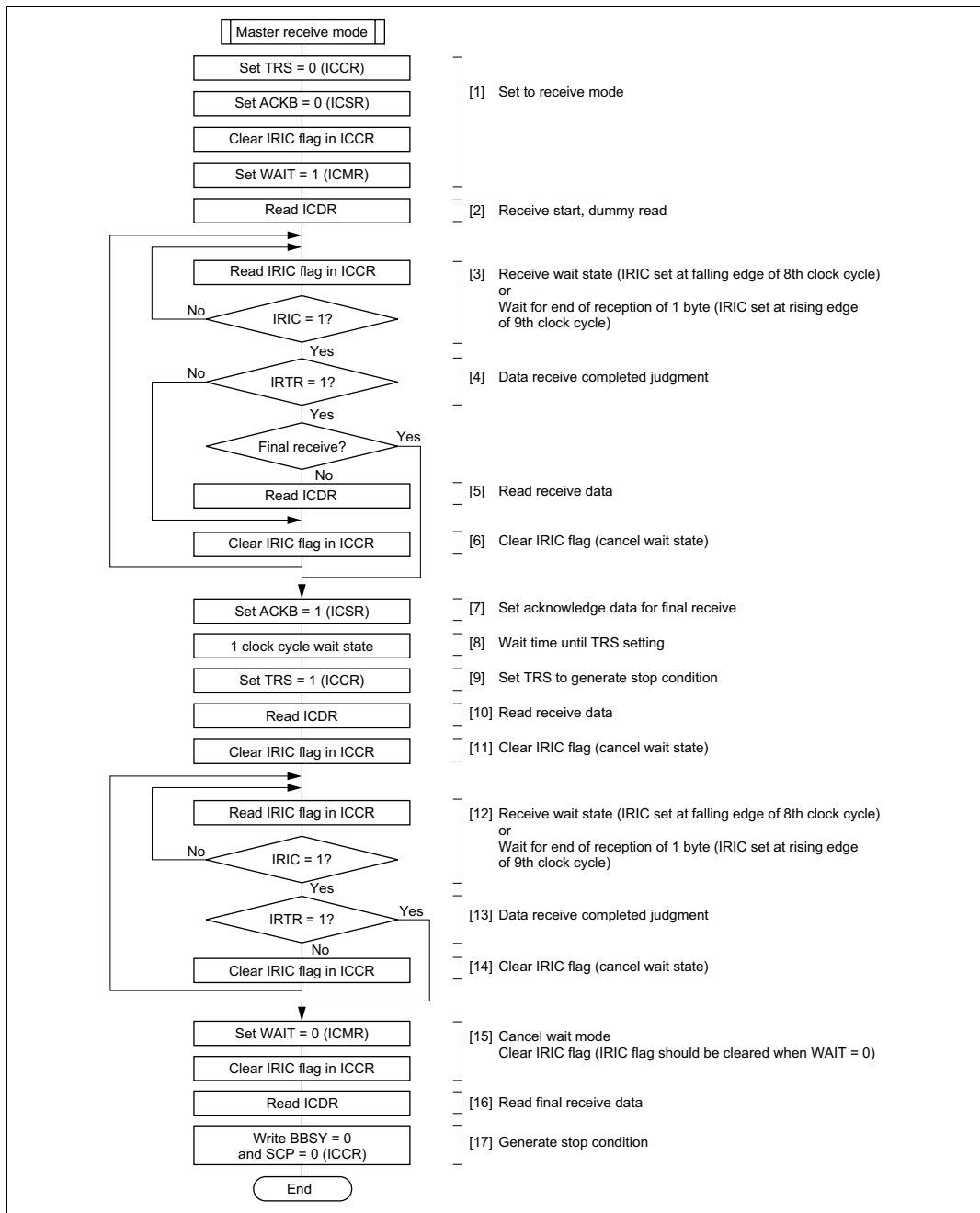

Figure 15-10 Flowchart for Master Receive Mode (Receiving Multiple Bytes) (WAIT = 1) (Example)

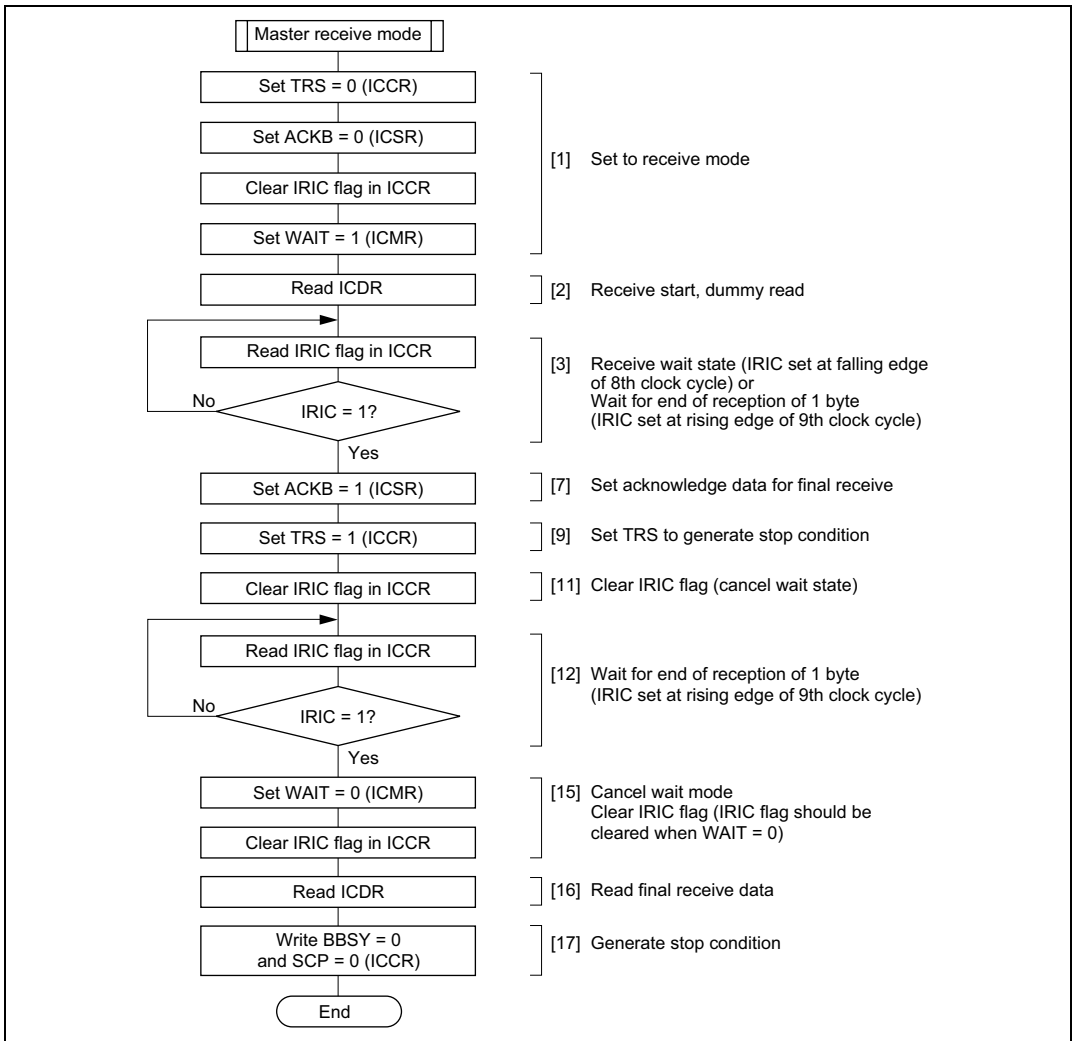

Figure 15-11 Flowchart for Master Receive Mode (Receiving 1 Byte) (WAIT = 1) (Example)

The procedure for receiving data sequentially, using the wait states (WAIT bit) for synchronization with ICDR (ICDRR) read operations, is described below.

The procedure below describes the operation for receiving multiple bytes. Note that some of the steps are omitted when receiving only 1 byte. Refer to figure 15-11 for details.

- [1] Clear the TRS bit in ICCR to 0 to switch from transmit mode to receive mode. Clear the ACKB bit in ICSR to 0 (acknowledge data setting). Clear the IRIC flag to 0, then set the WAIT bit in ICMR to 1.
- [2] When ICDR is read (dummy data read), reception is started, and the receive clock is output, and data received, in synchronization with the internal clock.
- [3] The IRIC flag is set to 1 by the following two conditions. At that point, an interrupt request is issued to the CPU if the IEIC bit in ICCR is set to 1.
 1. The flag is set at the falling edge of the 8th clock cycle of the receive clock for 1 frame. SCL is automatically held low, in synchronization with the internal clock, until the IRIC flag is cleared.
 2. The flag is set at the rising edge of the 9th clock cycle of the receive clock for 1 frame. The IRIC flag and ICDRF flag are set to 1, indicating that reception of 1 frame of data has ended. The master device continues to output the receive clock for the receive data.
- [4] Read the IRTR flag in ICSR. If the IRTR flag value is 0, the wait state is cancelled by clearing the IRIC flag as described in step [6] below. If the IRTR flag value is 1 and the next receive data is the final receive data, perform the end processing described in step [7] below.
- [5] If the IRTR flag value is 1, read the ICDR receive data.
- [6] Clear the IRTR flag to 0. If condition [3]-1 is true, the master device drives SDA to low level and returns an acknowledge signal when the receive clock outputs the 9th clock cycle. Further data can be received by repeating steps [3] through [6].
- [7] Set the ACKB bit in ICSR to 1 to set the acknowledge data for the final receive.
- [8] Wait for at least 1 clock cycle after the IRIC flag is set to 1 and then wait for the rising edge of the 1st clock cycle of the next receive data.
- [9] Set the TSR bit in ICCR to 1 to switch from the receive mode to the transmit mode. The TSR bit setting value at this point becomes valid when the rising edge of the next 9th clock cycle is input.
- [10] Read the ICDR receive data.
- [11] Clear the IRTR flag to 0.
- [12] The IRIC flag is set to 1 by the following two conditions.
 1. The flag is set at the falling edge of the 8th clock cycle of the receive clock for 1 frame. SCL is automatically held low, in synchronization with the internal clock, until the IRIC flag is cleared.
 2. The flag is set at the rising edge of the 9th clock cycle of the receive clock for 1 frame. The IRIC flag and ICDRF flag are set to 1, indicating that reception of 1 frame of data has ended. The master device continues to output the receive clock for the receive data.
- [13] Read the IRTR flag in ICSR. If the IRTR flag value is 0, the wait state is cancelled by clearing the IRIC flag as described in step [14] below. If the IRTR flag value is 1 and the

receive operation has finished, perform the issue stop condition processing described in step [15] below.

- [14] If the IRTR flag value is 0, clear the IRIC flag to 0 to cancel the wait state. Return to reading the IRIC flag, as described in step [12], to detect the end of the receive operation.
- [15] Clear the WAIT bit in ICMR to 0 to cancel the wait mode. Then clear the IRIC flag to 0. The IRIC flag should be cleared when the value of WAIT is 0 (The stop condition may not be output properly when the issue stop condition instruction is executed if the WAIT bit was cleared to 0 after the IRIC flag is cleared to 0).
- [16] Read the final receive data in ICDR.
- [17] Write 0 to BBSY and SCP in ICCR. This changes SDA from low to high when SCL is high, and generates the stop condition.

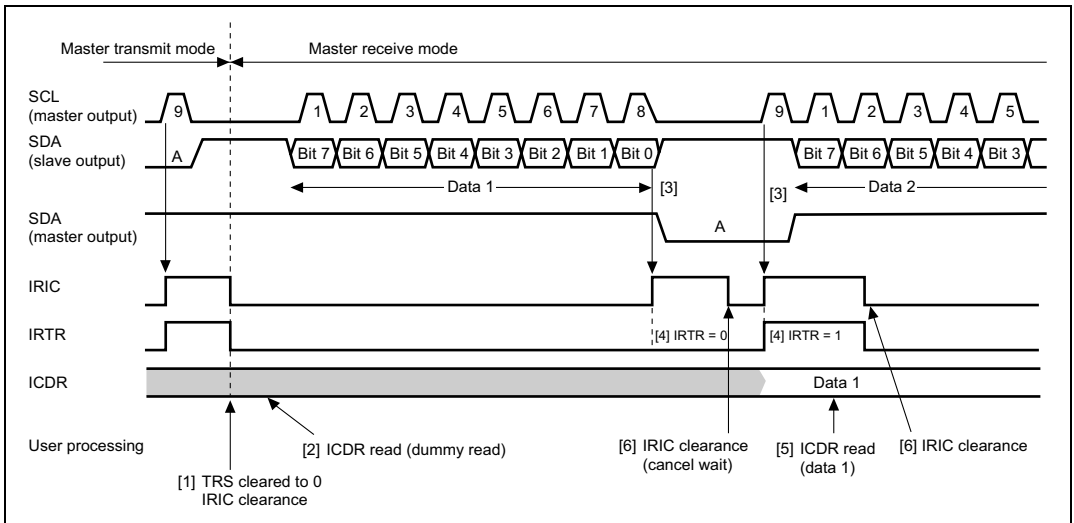

Figure 15-12 Example of Master Receive Mode Operation Timing
(MLS = ACKB = 0, WAIT = 1)

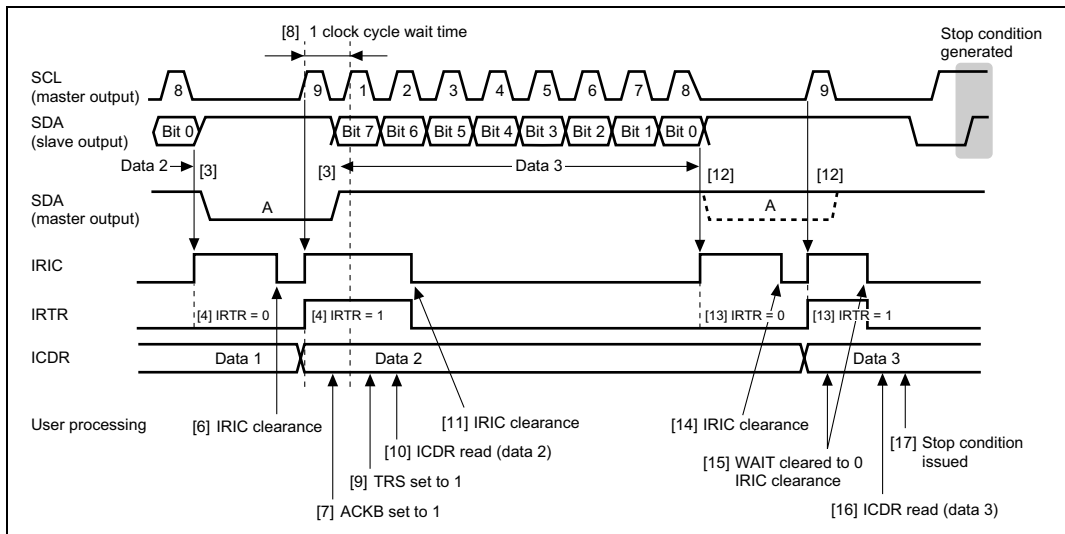

Figure 15-13 Example of Master Receive Mode Stop Condition Generation Timing (MLS = ACKB = 0, WAIT = 1)

15.3.5 Slave Receive Operation

In slave receive mode, the master device outputs the transmit clock and transmit data, and the slave device returns an acknowledge signal.

The slave device compares its own address with the slave address in the first frame following the establishment of the start condition issued by the master device. If the addresses match, the slave device operates as the slave device designated by the master device.

Figure 15-14 is a flowchart showing an example of slave receive mode operation.

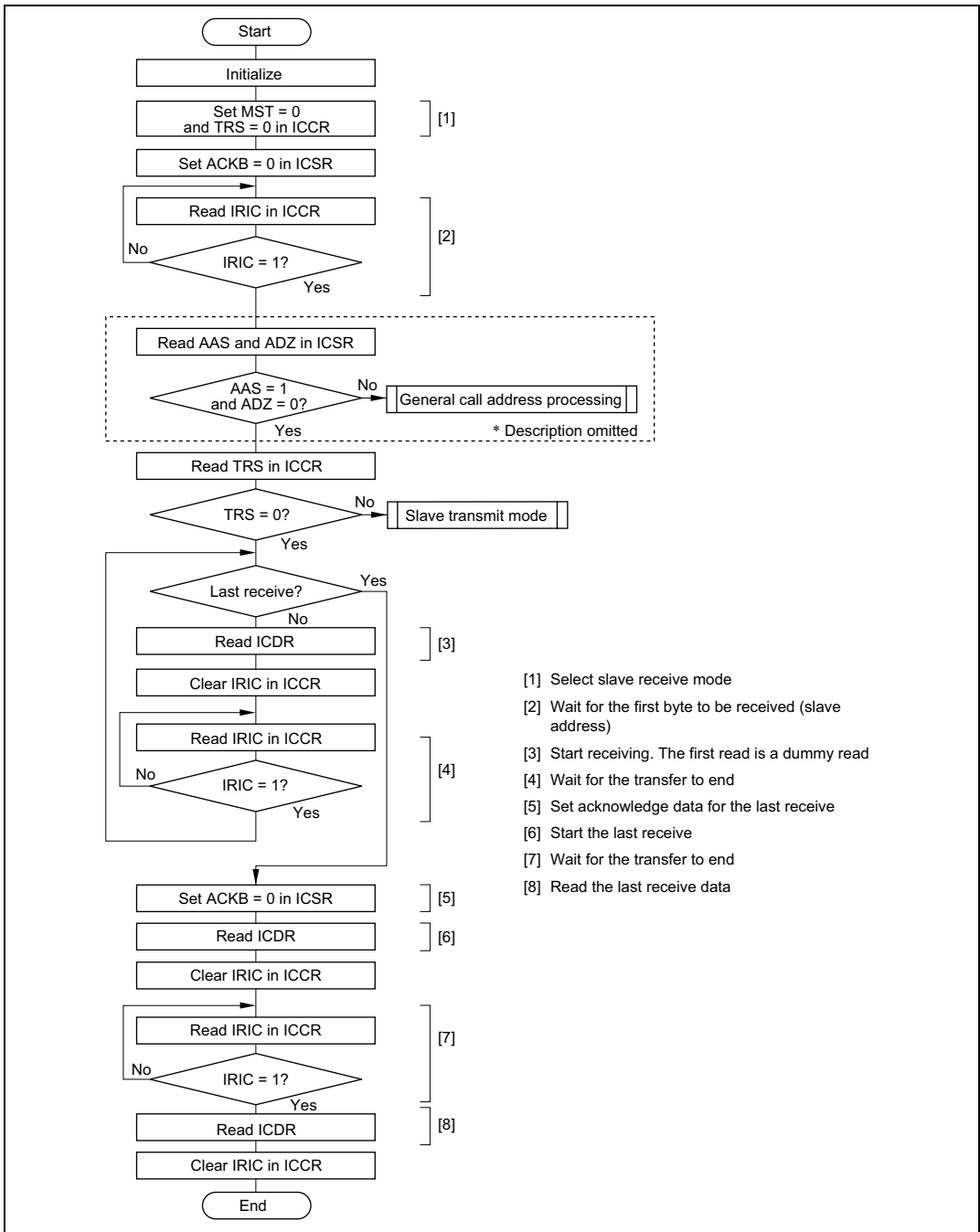

- [1] Select slave receive mode
- [2] Wait for the first byte to be received (slave address)
- [3] Start receiving. The first read is a dummy read
- [4] Wait for the transfer to end
- [5] Set acknowledge data for the last receive
- [6] Start the last receive
- [7] Wait for the transfer to end
- [8] Read the last receive data

Figure 15-14 Flowchart for Slave Transmit Mode (Example)

The reception procedure and operations in slave receive mode are described below.

- (1) Set the ICE bit in ICCR to 1. Set the MLS bit in ICMR and the MST and TRS bits in ICCR according to the operating mode.
- (2) When the start condition output by the master device is detected, the BBSY flag in ICCR is set to 1.
- (3) When the slave address matches in the first frame following the start condition, the device operates as the slave device specified by the master device. If the 8th data bit (R/\overline{W}) is 0, the TRS bit in ICCR remains cleared to 0, and slave receive operation is performed.
- (4) At the 9th clock pulse of the receive frame, the slave device drives SDA low and returns an acknowledge signal. At the same time, the IRIC flag in ICCR is set to 1. If the IEIC bit in ICCR has been set to 1, an interrupt request is sent to the CPU. If the RDRF internal flag has been cleared to 0, it is set to 1, and the receive operation continues. If the RDRF internal flag has been set to 1, the slave device drives SCL low from the fall of the receive clock until data is read into ICDR.
- (5) Read ICDR and clear the IRIC flag in ICCR to 0. The RDRF flag is cleared to 0.

Receive operations can be performed continuously by repeating steps (4) and (5). When SDA is changed from low to high when SCL is high, and the stop condition is detected, the BBSY flag in ICCR is cleared to 0.

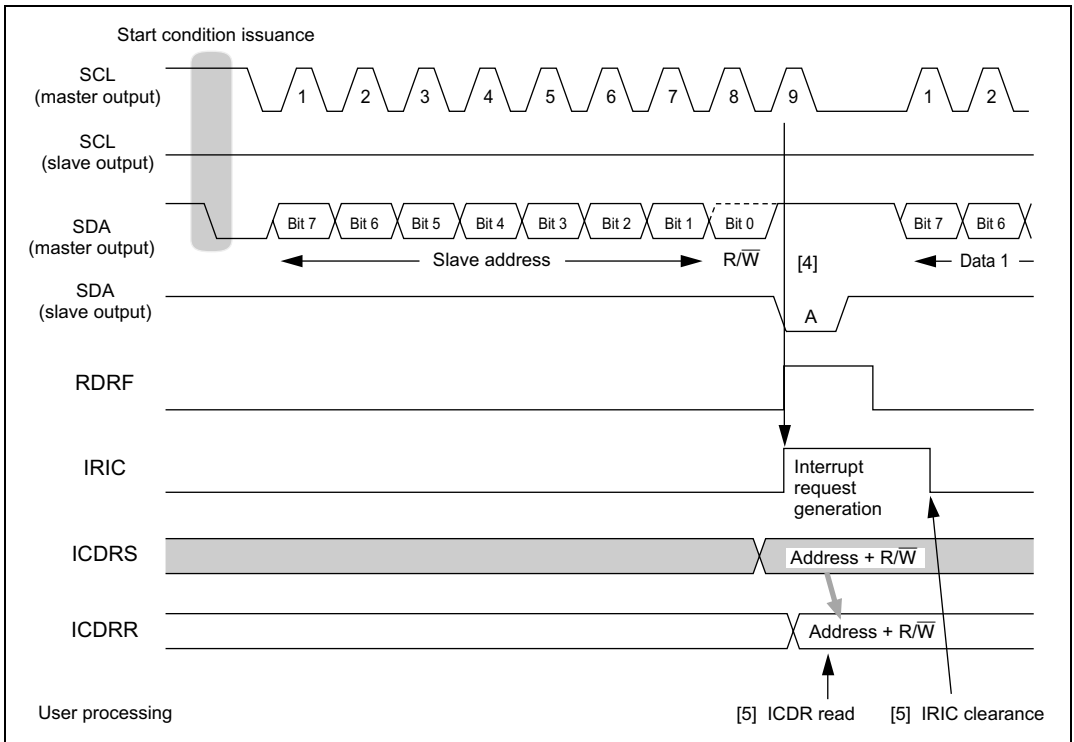

Figure 15-15 Example of Slave Receive Mode Operation Timing (1)
(MLS = ACKB = 0)

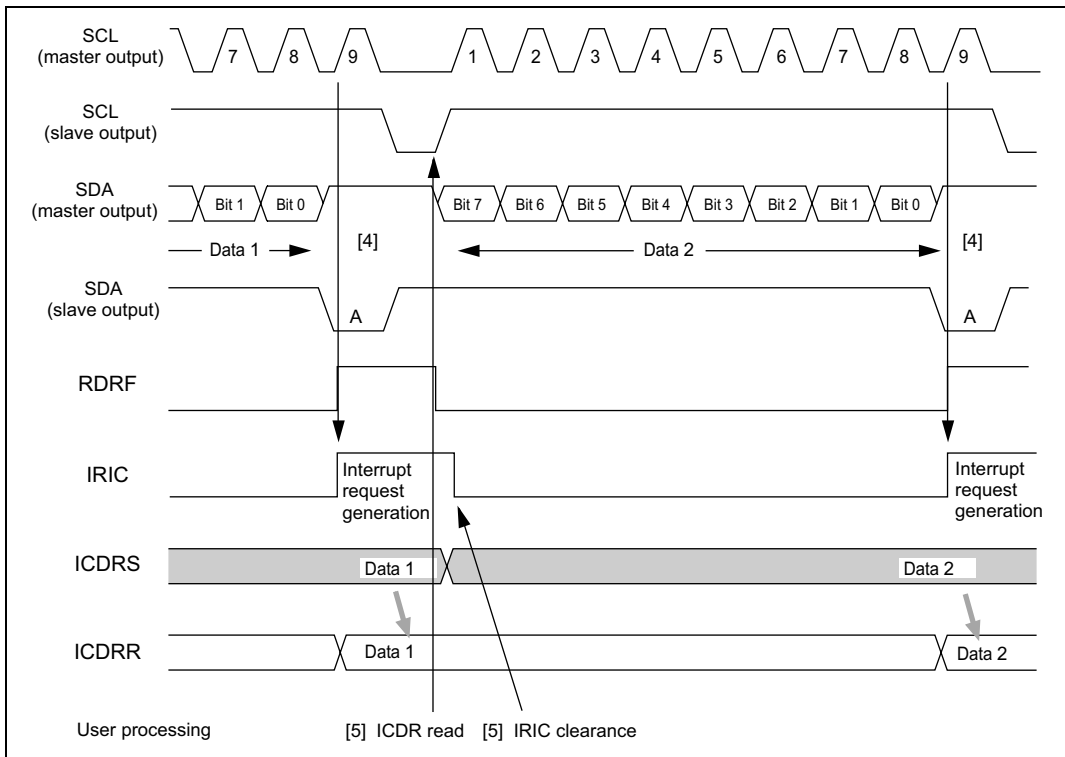

Figure 15-16 Example of Slave Receive Mode Operation Timing (2)
($MLS = ACKB = 0$)

15.3.6 Slave Transmit Operation

In slave transmit operation, the slave device compares its own address with the slave address transmitted by the master device in the first frame (address receive frame) following detection of the start condition. If the addresses match and the 8th bit (R/W) is set to 1 (read), the TRS bit in ICCR is automatically set to 1 and slave transmit mode is activated.

Figure 15-17 is a flowchart showing an example of slave transmit mode operation.

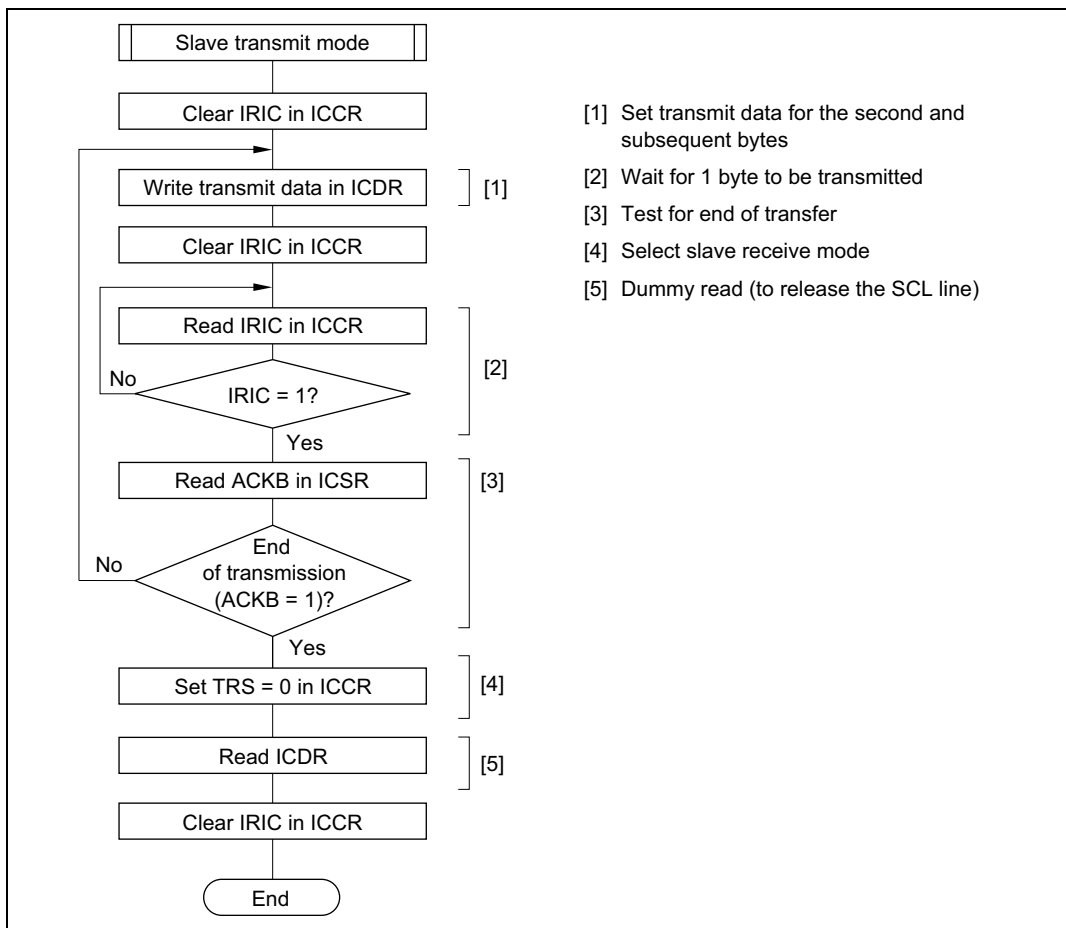

Figure 15-17 Flowchart for Slave Receive Mode (Example)

In slave transmit mode, the slave device outputs the transmit data, while the master device outputs the receive clock and returns an acknowledge signal. The transmission procedure and operations in slave transmit mode are described below.

- (1) Set the ICE bit in ICCR to 1. Set the MLS bit in ICMR and the MST and TRS bits in ICCR according to the operating mode.
- (2) When the slave address matches in the first frame following detection of the start condition, the slave device drives SDA low at the 9th clock pulse and returns an acknowledge signal. At the same time, the IRIC flag in ICCR is set to 1. If the IEIC bit in ICCR has been set to 1, an interrupt request is sent to the CPU. If the 8th data bit (R/\overline{W}) is 1, the TRS bit in ICCR is set to 1, and the mode changes to slave transmit mode automatically. The TDRF flag is set to 1. The slave device drives SCL low from the fall of the transmit clock until ICDR data is written.
- (3) After clearing the IRIC flag to 0, write data to ICDR. The TDRE internal flag is cleared to 0. The written data is transferred to ICDRS, and the TDRE internal flag and the IRIC and IRTR flags are set to 1 again. After clearing the IRIC flag to 0, write the next data to ICDR. The slave device sequentially sends the data written into ICDR in accordance with the clock output by the master device at the timing shown in figure 15-18.
- (4) When one frame of data has been transmitted, the IRIC flag in ICCR is set to 1 at the rise of the 9th transmit clock pulse. If the TDRE internal flag has been set to 1, this slave device drives SCL low from the fall of the transmit clock until data is written to ICDR. The master device drives SDA low at the 9th clock pulse, and returns an acknowledge signal. As this acknowledge signal is stored in the ACKB bit in ICSR, this bit can be used to determine whether the transfer operation was performed normally. When the TDRE internal flag is 0, the data written into ICDR is transferred to ICDRS, transmission is started, and the TDRE internal flag and the IRIC and IRTR flags are set to 1 again.
- (5) To continue transmission, clear the IRIC flag to 0, then write the next data to be transmitted into ICDR. The TDRE flag is cleared to 0.

Transmit operations can be performed continuously by repeating steps (4) and (5). To end transmission, write H'FF to ICDR to release SDA on the slave side. When SDA is changed from low to high when SCL is high, and the stop condition is detected, the BBSY flag in ICCR is cleared to 0.

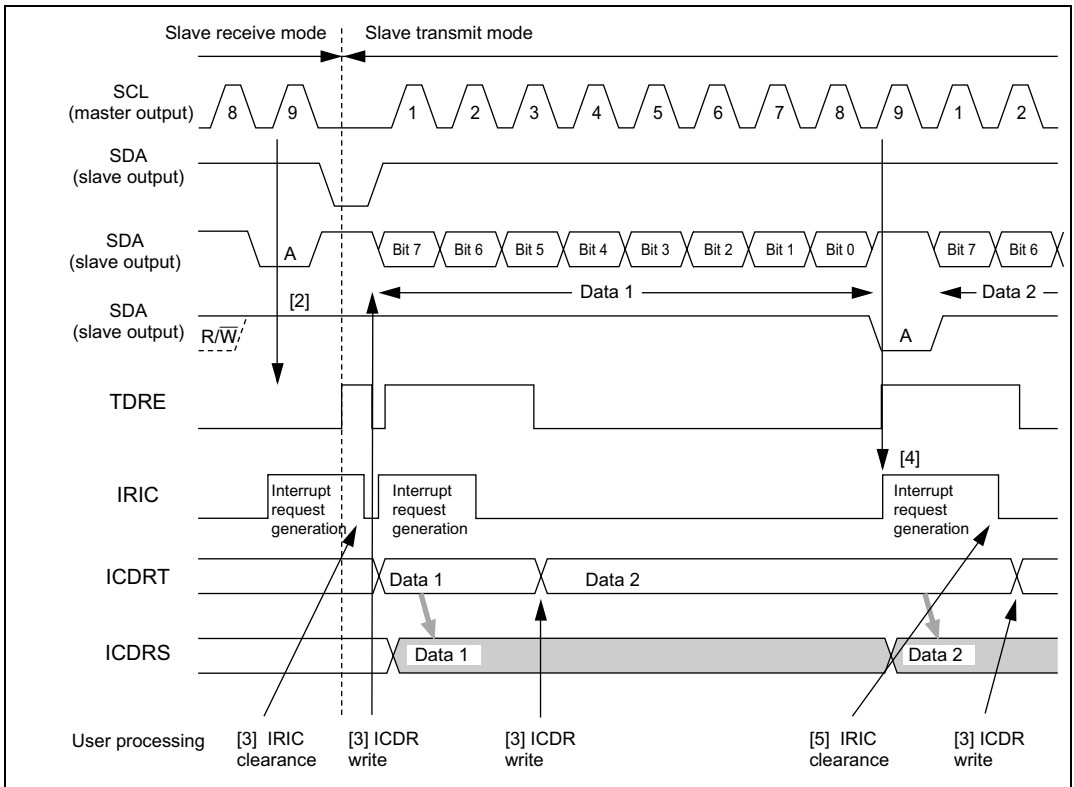

Figure 15-18 Example of Slave Transmit Mode Operation Timing (MLS = 0)

15.3.7 IRIC Setting Timing and SCL Control

The interrupt request flag (IRIC) is set at different times depending on the WAIT bit in ICMR, the FS bit in SAR, and the FSX bit in SARX. If the TDRE or RDRF internal flag is set to 1, SCL is automatically held low after one frame has been transferred; this timing is synchronized with the internal clock. Figure 15-19 shows the IRIC set timing and SCL control.

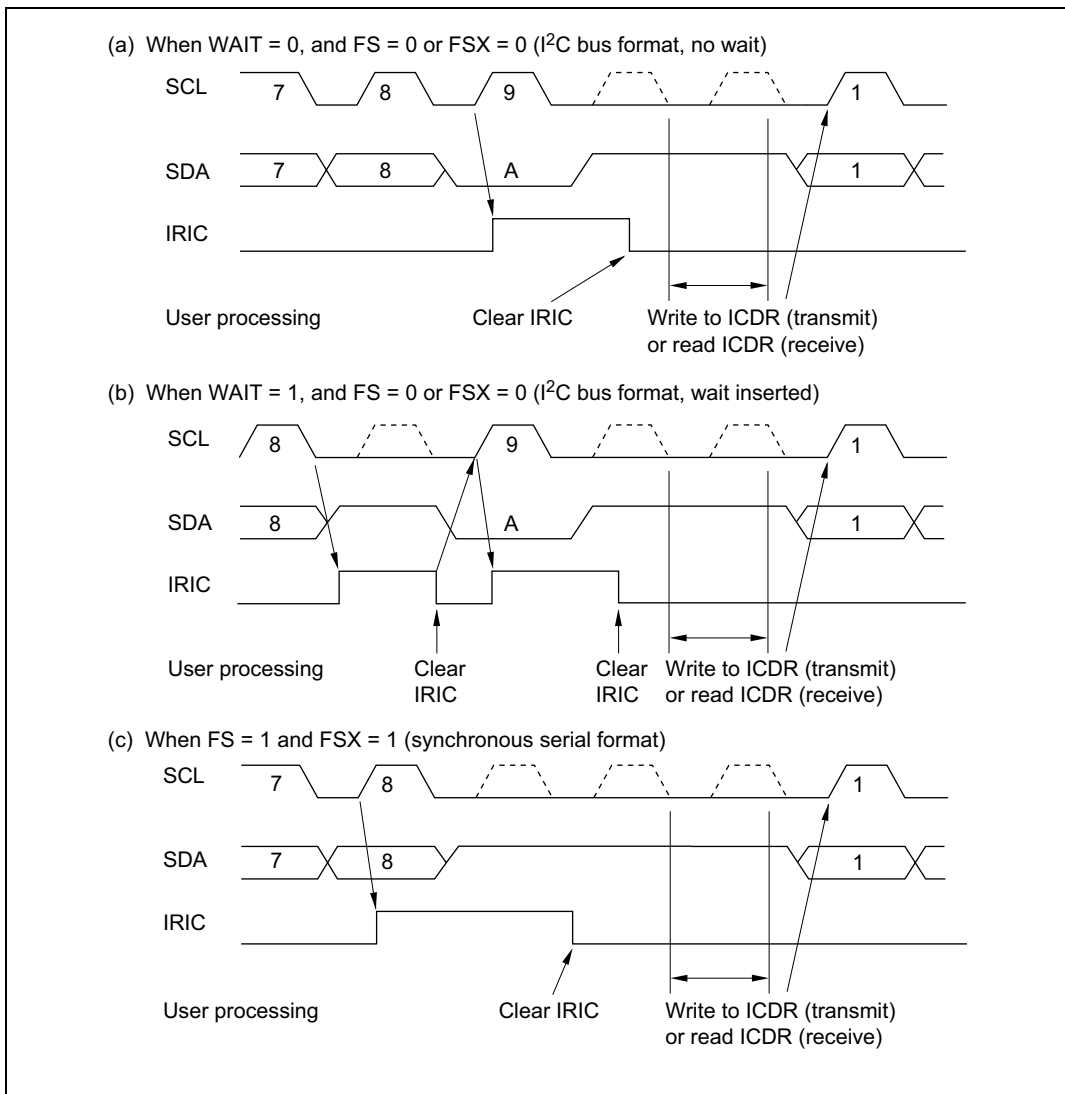

Figure 15-19 IRIC Setting Timing and SCL Control

15.3.8 Operation Using the DTC

The I²C bus format provides for selection of the slave device and transfer direction by means of the slave address and the R/ \bar{W} bit, confirmation of reception with the acknowledge bit, indication of the last frame, and so on. Therefore, continuous data transfer using the DTC must be carried out in conjunction with CPU processing by means of interrupts.

Table 15-5 shows some examples of processing using the DTC. These examples assume that the number of transfer data bytes is known in slave mode.

Table 15-5 Examples of Operation Using the DTC

Item	Master Transmit Mode	Master Receive Mode	Slave Transmit Mode	Slave Receive Mode
Slave address + R/ \bar{W} bit transmission/reception	Transmission by DTC (ICDR write)	Transmission by CPU (ICDR write)	Reception by CPU (ICDR read)	Reception by CPU (ICDR read)
Dummy data read	—	Processing by CPU (ICDR read)	—	—
Actual data transmission/reception	Transmission by DTC (ICDR write)	Reception by DTC (ICDR read)	Transmission by DTC (ICDR write)	Reception by DTC (ICDR read)
Dummy data (H'FF) write	—	—	Processing by DTC (ICDR write)	—
Last frame processing	Not necessary	Reception by CPU (ICDR read)	Not necessary	Reception by CPU (ICDR read)
Transfer request processing after last frame processing	1st time: Clearing by CPU 2nd time: End condition issuance by CPU	Not necessary	Automatic clearing on detection of end condition during transmission of dummy data (H'FF)	Not necessary
Setting of number of DTC transfer data frames	Transmission: Actual data count + 1 (+1 equivalent to slave address + R/ \bar{W} bits)	Reception: Actual data count	Transmission: Actual data count + 1 (+1 equivalent to dummy data (H'FF))	Reception: Actual data count

15.3.9 Noise Canceler

The logic levels at the SCL and SDA pins are routed through noise cancelers before being latched internally. Figure 15-20 shows a block diagram of the noise canceler circuit.

The noise canceler consists of two cascaded latches and a match detector. The SCL (or SDA) input signal is sampled on the system clock, but is not passed forward to the next circuit unless the outputs of both latches agree. If they do not agree, the previous value is held.

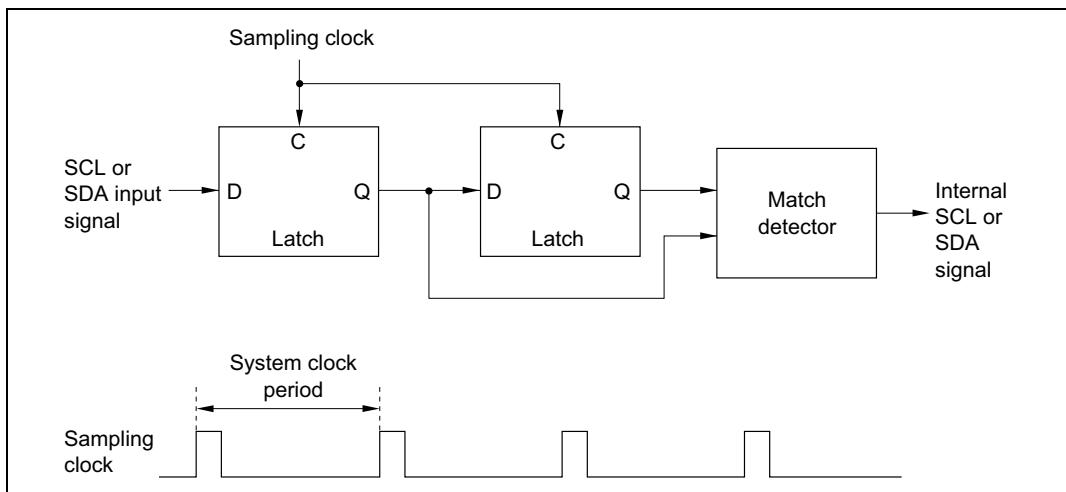

Figure 15-20 Block Diagram of Noise Canceler

15.3.10 Initialization of Internal State

The IIC has a function for forcible initialization of its internal state if a deadlock occurs during communication.

Initialization is executed by (1) setting bits CLR3 to CLR0 in the DDSCSWR register or (2) clearing the ICE bit. For details of settings for bits CLR3 to CLR0, see section 15.2.8, DDC Switch Register (DDSCSWR).

Scope of Initialization: The initialization executed by this function covers the following items:

- TDRE and RDRF internal flags
- Transmit/receive sequencer and internal operating clock counter
- Internal latches for retaining the output state of the SCL and SDA pins (wait, clock, data output, etc.)

The following items are not initialized:

- Actual register values (ICDR, SAR, SARX, ICMR, ICCR, ICSR, DDCCSWR, and STCR)
- Internal latches used to retain register read information for setting/clearing flags in the ICMR, ICCR, ICSR, and DDCCSWR registers
- The value of the ICMR register bit counter (BC2 to BC0)
- Generated interrupt sources (interrupt sources transferred to the interrupt controller)

Notes on Initialization:

- Interrupt flags and interrupt sources are not cleared, and so flag clearing measures must be taken as necessary.
- Basically, other register flags are not cleared either, and so flag clearing measures must be taken as necessary.
- When initialization is performed by means of the DDCCSWR register, the write data for bits CLR3 to CLR0 is not retained. To perform IIC clearance, bits CLR3 to CLR0 must be written to simultaneously using an MOV instruction. Do not use a bit manipulation instruction such as BCLR. Similarly, when clearing is required again, all the bits must be written to simultaneously in accordance with the setting.
- If a flag clearing setting is made during transmission/reception, the IIC module will stop transmitting/receiving at that point and the SCL and SDA pins will be released. When transmission/reception is started again, register initialization, etc., must be carried out as necessary to enable correct communication as a system.

The value of the BBSY bit cannot be modified directly by this module clear function, but since the stop condition pin waveform is generated according to the state and release timing of the SCL and SDA pins, the BBSY bit may be cleared as a result. Similarly, state switching of other bits and flags may also have an effect.

To prevent problems caused by these factors, the following procedure should be used when initializing the IIC state.

1. Execute initialization of the internal state according to the setting of bits CLR3 to CLR0, or according to the ICE bit.
2. Execute a stop condition issuance instruction (write 0 to BBSY and SCP) to clear the BBST bit to 0, and wait for two transfer rate clock cycles.
3. Re-execute initialization of the internal state according to the setting of bits CLR3 to CLR0, or according to the ICE bit.
4. Initialize (re-set) the IIC registers.

15.4 Usage Notes

- In master mode, if an instruction to generate a start condition is immediately followed by an instruction to generate a stop condition, neither condition will be output correctly. To output consecutive start and stop conditions, after issuing the instruction that generates the start condition, read the relevant ports, check that SCL and SDA are both low, then issue the instruction that generates the stop condition. Note that SCL may not yet have gone low when BBSY is cleared to 0.
- Either of the following two conditions will start the next transfer. Pay attention to these conditions when reading or writing to ICDR.
 - Write access to ICDR when ICE = 1 and TRS = 1 (including automatic transfer from ICDRT to ICDRS)
 - Read access to ICDR when ICE = 1 and TRS = 0 (including automatic transfer from ICDRS to ICDRR)
- Table 15-6 shows the timing of SCL and SDA output in synchronization with the internal clock. Timings on the bus are determined by the rise and fall times of signals affected by the bus load capacitance, series resistance, and parallel resistance.

Table 15-6 I²C Bus Timing (SCL and SDA Output)

Item	Symbol	Output Timing	Unit	Notes
SCL output cycle time	t_{SCLC}	28 t_{cyc} to 256 t_{cyc}	ns	Figure 24-28 (reference)
SCL output high pulse width	t_{SCLHO}	0.5 t_{SCLC}	ns	
SCL output low pulse width	t_{SCLLO}	0.5 t_{SCLC}	ns	
SDA output bus free time	t_{BUFO}	0.5 t_{SCLC} - 1 t_{cyc}	ns	
Start condition output hold time	t_{STAHO}	0.5 t_{SCLC} - 1 t_{cyc}	ns	
Retransmission start condition output setup time	t_{STASO}	1 t_{SCLC}	ns	
Stop condition output setup time	t_{STOSO}	0.5 t_{SCLC} + 2 t_{cyc}	ns	
Data output setup time (master)	t_{SDASO}	1 t_{SCLLO} - 3 t_{cyc}	ns	
Data output setup time (slave)		1 t_{SCLL} - 3 t_{cyc}		
Data output hold time	t_{SDAHO}	3 t_{cyc}	ns	

- SCL and SDA input is sampled in synchronization with the internal clock. The AC timing therefore depends on the system clock cycle t_{cyc} , as shown in tables 24-19, 24-31, 24-43 in section 24, Electrical Characteristics. Note that the I²C bus interface AC timing specifications will not be met with a system clock frequency of less than 5 MHz.
- The I²C bus interface specification for the SCL rise time t_{sr} is under 1000 ns (300 ns for high-speed mode). In master mode, the I²C bus interface monitors the SCL line and synchronizes one bit at a time during communication. If t_{sr} (the time for SCL to go from low to V_{IH}) exceeds the time determined by the input clock of the I²C bus interface, the high period of SCL is extended. The SCL rise time is determined by the pull-up resistance and load capacitance of the SCL line. To insure proper operation at the set transfer rate, adjust the pull-up resistance and load capacitance so that the SCL rise time does not exceed the values given in the table 15-7.

Table 15-7 Permissible SCL Rise Time (t_{sr}) Values

t_{cyc} IICX Indication		I ² C Bus Specification (Max.)	Time Indication					
			$\phi =$ 5 MHz	$\phi =$ 8 MHz	$\phi =$ 10 MHz	$\phi =$ 16 MHz	$\phi =$ 20 MHz	
0	7.5 t_{cyc}	Standard mode	1000 ns	1000 ns	937 ns	750 ns	468 ns	375 ns
		High-speed mode	300 ns	300 ns	300 ns	300 ns	300 ns	300 ns
1	17.5 t_{cyc}	Standard mode	1000 ns	1000 ns	1000 ns	1000 ns	1000 ns	875 ns
		High-speed mode	300 ns	300 ns	300 ns	300 ns	300 ns	300 ns

- The I²C bus interface specifications for the SCL and SDA rise and fall times are under 1000 ns and 300 ns. The I²C bus interface SCL and SDA output timing is prescribed by $t_{S_{cyc}}$ and $t_{c_{yc}}$, as shown in table 15-6. However, because of the rise and fall times, the I²C bus interface specifications may not be satisfied at the maximum transfer rate. Table 15-8 shows output timing calculations for different operating frequencies, including the worst-case influence of rise and fall times.

t_{BUFO} fails to meet the I²C bus interface specifications at any frequency. The solution is either (a) to provide coding to secure the necessary interval (approximately 1 μ s) between issuance of a stop condition and issuance of a start condition, or (b) to select devices whose input timing permits this output timing for use as slave devices connected to the I²C bus.

t_{SCLLO} in high-speed mode and t_{STASO} in standard mode fail to satisfy the I²C bus interface specifications for worst-case calculations of t_{Sr}/t_{Sf} . Possible solutions that should be investigated include (a) adjusting the rise and fall times by means of a pull-up resistor and capacitive load, (b) reducing the transfer rate to meet the specifications, or (c) selecting devices whose input timing permits this output timing for use as slave devices connected to the I²C bus.

Table 15-8 I²C Bus Timing (with Maximum Influence of t_{Sr}/t_{Sf})

Item	t_{cyc} Indication		Time Indication (at Maximum Transfer Rate) [ns]						
			t_{Sr}/t_{Sf} Influence (Max.)	I ² C Bus Specifi- cation (Min.)	$\phi =$ 5 MHz	$\phi =$ 8 MHz	$\phi =$ 10 MHz	$\phi =$ 16 MHz	$\phi =$ 20 MHz
t_{SCLHO}	0.5 t_{SCLO} ($-t_{Sr}$)	Standard mode	-1000	4000	4000	4000	4000	4000	4000
		High-speed mode	-300	600	950	950	950	950	950
t_{SCLLO}	0.5 t_{SCLO} ($-t_{Sf}$)	Standard mode	-250	4700	4750	4750	4750	4750	4750
		High-speed mode	-250	1300	1000 ^{*1}	1000 ^{*1}	1000 ^{*1}	1000 ^{*1}	1000 ^{*1}
t_{BUFO}	0.5 t_{SCLO} - 1 t_{cyc} ($-t_{Sr}$)	Standard mode	-1000	4700	3800 ^{*1}	3875 ^{*1}	3900 ^{*1}	3938 ^{*1}	3950 ^{*1}
		High-speed mode	-300	1300	750 ^{*1}	825 ^{*1}	850 ^{*1}	888 ^{*1}	900 ^{*1}
t_{STAH0}	0.5 t_{SCLO} - 1 t_{cyc} ($-t_{Sr}$)	Standard mode	-250	4000	4550	4625	4650	4688	4700
		High-speed mode	-250	600	800	875	900	938	950
t_{STAS0}	1 t_{SCLO} ($-t_{Sr}$)	Standard mode	-1000	4700	9000	9000	9000	9000	9000
		High-speed mode	-300	600	2200	2200	2200	2200	2200
t_{STOSO}	0.5 t_{SCLO} + 2 t_{cyc} ($-t_{Sr}$)	Standard mode	-1000	4000	4400	4250	4200	4125	4100
		High-speed mode	-300	600	1350	1200	1150	1075	1050
t_{SDAS0} (master)	1 t_{SCLLO} ^{*2} - 3 t_{cyc} ($-t_{Sr}$)	Standard mode	-1000	250	3100	3325	3400	3513	3550
		High-speed mode	-300	100	400	625	700	813	850
t_{SDAS0} (slave)	1 t_{SCLL} ^{*2} - 3 t_{cyc} ^{*2} ($-t_{Sr}$)	Standard mode	-1000	250	3100	3325	3400	3513	3550
		High-speed mode	-300	100	400	625	700	813	850

Time Indication (at Maximum Transfer Rate) [ns]

Item	t _{cyc} Indication	t _{Sr} /t _{Sf} Influence (Max.)	I ² C Bus Specifi- cation (Min.)						
			φ = 5 MHz	φ = 8 MHz	φ = 10 MHz	φ = 16 MHz	φ = 20 MHz		
t _{SDAHO}	3 t _{cyc}	Standard mode	0	0	600	375	300	188	150
		High-speed mode	0	0	600	375	300	188	150

- Notes: 1. Does not meet the I²C bus interface specification. Remedial action such as the following is necessary: (a) secure a start/stop condition issuance interval; (b) adjust the rise and fall times by means of a pull-up resistor and capacitive load; (c) reduce the transfer rate; (d) select slave devices whose input timing permits this output timing. The values in the above table will vary depending on the settings of the IICX bit and bits CKS0 to CKS2. Depending on the frequency it may not be possible to achieve the maximum transfer rate; therefore, whether or not the I²C bus interface specifications are met must be determined in accordance with the actual setting conditions.
2. Calculated using the I²C bus specification values (standard mode: 4700 ns min.; high-speed mode: 1300 ns min.).

- Note on ICDR Read at End of Master Reception

To halt reception at the end of a receive operation in master receive mode, set the TRS bit to 1 and write 0 to BBSY and SCP in ICCR. This changes SDA from low to high when SCL is high, and generates the stop condition. After this, receive data can be read by means of an ICDR read, but if data remains in the buffer the ICDRS receive data will not be transferred to ICDR, and so it will not be possible to read the second byte of data.

If it is necessary to read the second byte of data, issue the stop condition in master receive mode (i.e. with the TRS bit cleared to 0). When reading the receive data, first confirm that the BBSY bit in the ICCR register is cleared to 0, the stop condition has been generated, and the bus has been released, then read the ICDR register with TRS cleared to 0.

Note that if the receive data (ICDR data) is read in the interval between execution of the instruction for issuance of the stop condition (writing of 0 to BBSY and SCP in ICCR) and the actual generation of the stop condition, the clock may not be output correctly in subsequent master transmission.

Clearing of the MST bit after completion of master transmission/reception, or other modifications of IIC control bits to change the transmit/receive operating mode or settings, must be carried out during interval (a) in figure 15-18 (after confirming that the BBSY bit has been cleared to 0 in the ICCR register).

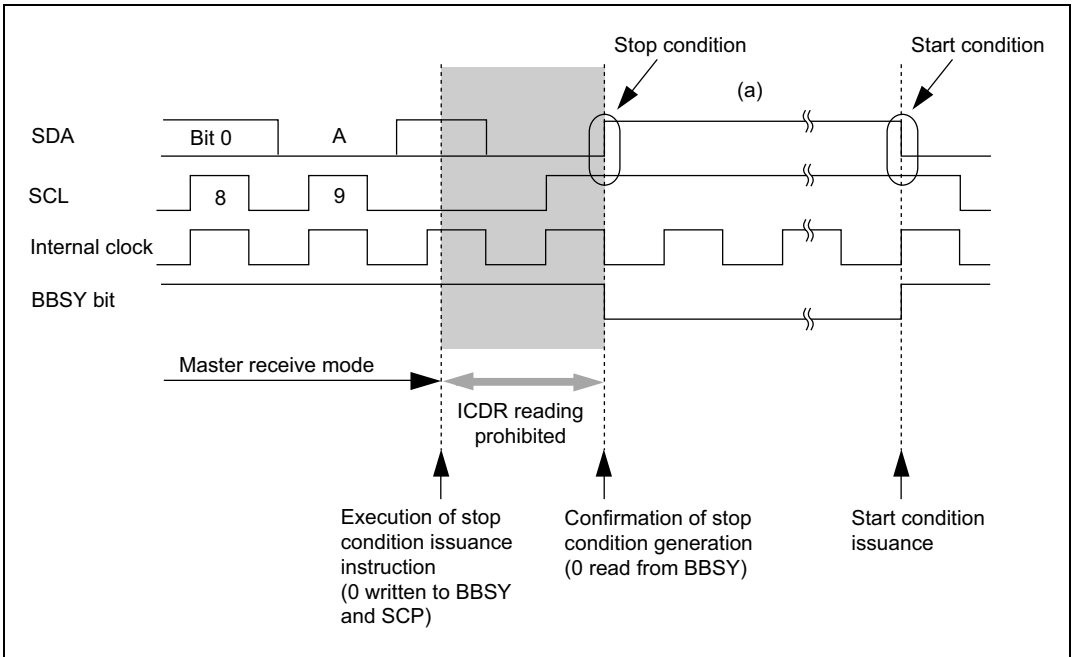

Figure 15-21 Points for Attention Concerning Reading of Master Receive Data

- Notes on Start Condition Issuance for Retransmission

Figure 15-22 shows the timing of start condition issuance for retransmission, and the timing for subsequently writing data to ICDR, together with the corresponding flowchart.

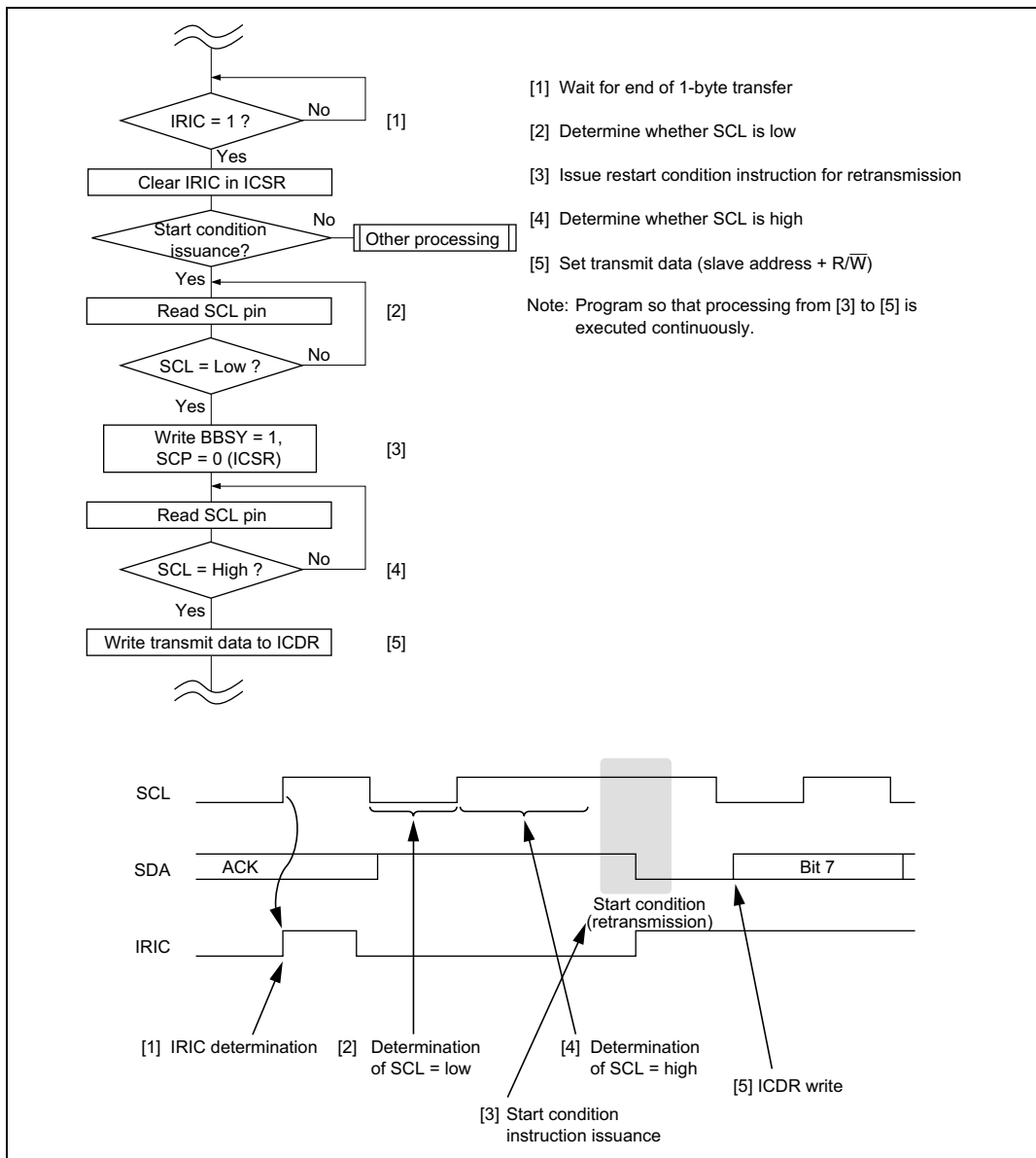

Figure 15-22 Flowchart and Timing of Start Condition Instruction Issuance for Retransmission

- Notes on I²C Bus Interface Stop Condition Instruction Issuance

If the rise time of the 9th SCL acknowledge exceeds the specification because the bus load capacitance is large, or if there is a slave device of the type that drives SCL low to effect a wait, issue the stop condition instruction after reading SCL and determining it to be low, as shown below.

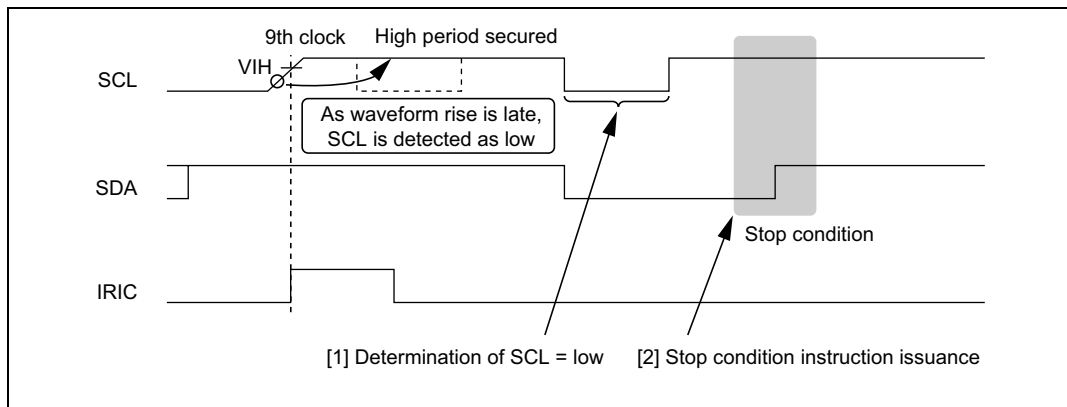

Figure 15-23 Timing of Stop Condition Issuance

- Notes on IRIC Flag Clearance when Using Wait Function

If the SCL rise time exceeds the designated duration or if the slave device is of the type that keeps SCL low and applies a wait state when the wait function is used in the master mode of the I²C bus interface, read SCL and clear the IRIC flag after determining that SCL has gone low, as shown below.

Clearing the IRIC flag to 0 when WAIT is set to 1 and SCL is being held at high level can cause the SDA value to change before SCL goes low, resulting in a start condition or stop condition being generated erroneously.

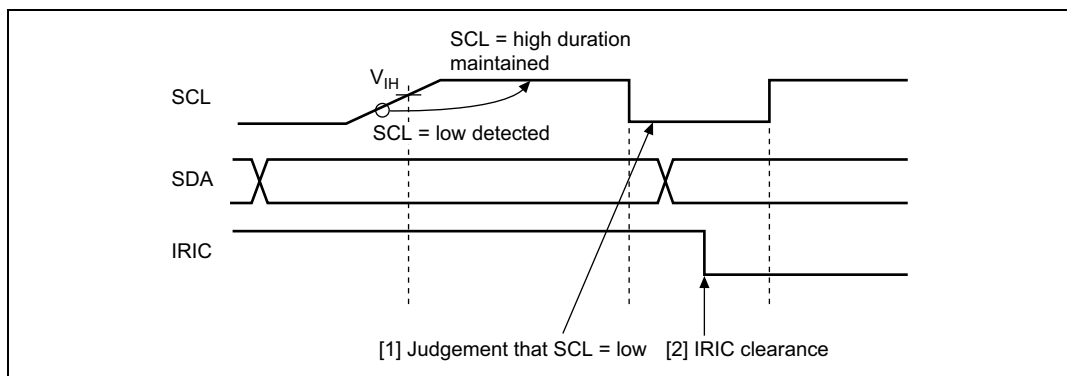

Figure 15-24 IRIC Flag Clearance in WAIT = 1 Status

- Notes on ICDR Reads and ICCR Access in Slave Transmit Mode

In a transmit operation in the slave mode of the I²C bus interface, do not read the ICDR register or read or write to the ICCR register during the period indicated by the shaded portion in figure 15-25.

Normally, when interrupt processing is triggered in synchronization with the rising edge of the 9th clock cycle, the period in question has already elapsed when the transition to interrupt processing takes place, so there is no problem with reading the ICDR register or reading or writing to the ICCR register.

To ensure that the interrupt processing is performed properly, one of the following two conditions should be applied.

- (1) Make sure that reading received data from the ICDR register, or reading or writing to the ICCR register, is completed before the next slave address receive operation starts.
- (2) Monitor the BC2 to BC0 counter in the ICMR register and, when the value of BC2 to BC0 is 000 (8th or 9th clock cycle), allow a waiting time of at least 2 transfer clock cycles in order to involve the problem period in question before reading from the ICDR register, or reading or writing to the ICCR register.

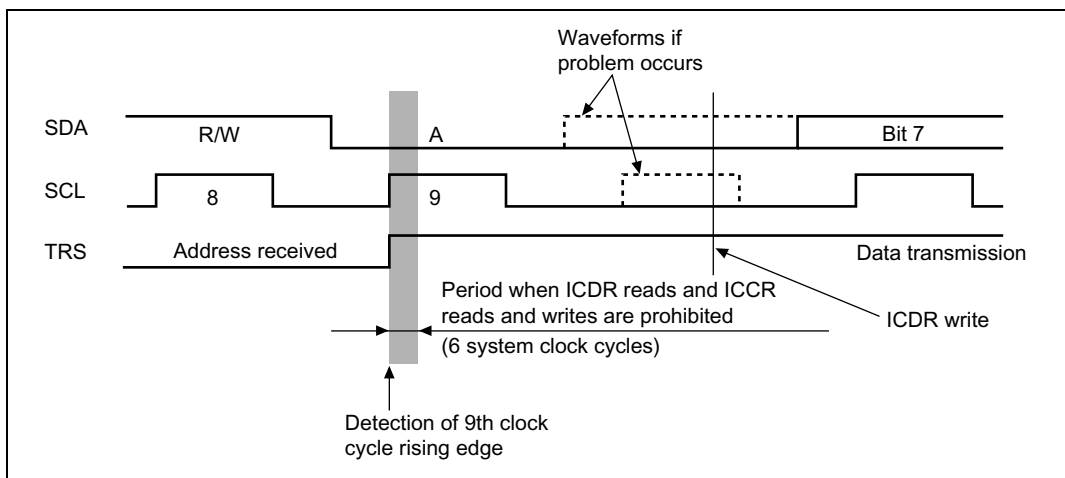

Figure 15-25 ICDR Read and ICCR Access Timing in Slave Transmit Mode

- Notes on TRS Bit Setting in Slave Mode

From the detection of the rising edge of the 9th clock cycle or of a stop condition to when the rising edge of the next SCL pin signal is detected (the period indicated as (a) in figure 15-26) in the slave mode of the I²C bus interface, the value set in the TRS bit in the ICCR register is effective immediately.

However, at other times (indicated as (b) in figure 15-26) the value set in the TRS bit is put on hold until the next rising edge of the 9th clock cycle or stop condition is detected, rather than taking effect immediately.

This results in the actual internal value of the TRS bit remaining 1 (transmit mode) and no acknowledge bit being sent at the 9th clock cycle address receive completion in the case of an address receive operation following a restart condition input with no stop condition intervening.

When receiving an address in the slave mode, clear the TRS bit to 0 during the period indicated as (a) in figure 15-26.

To cancel the holding of the SCL bit low by the wait function in the slave mode, clear the TRS bit to 0 and then perform a dummy read of the ICDR register.

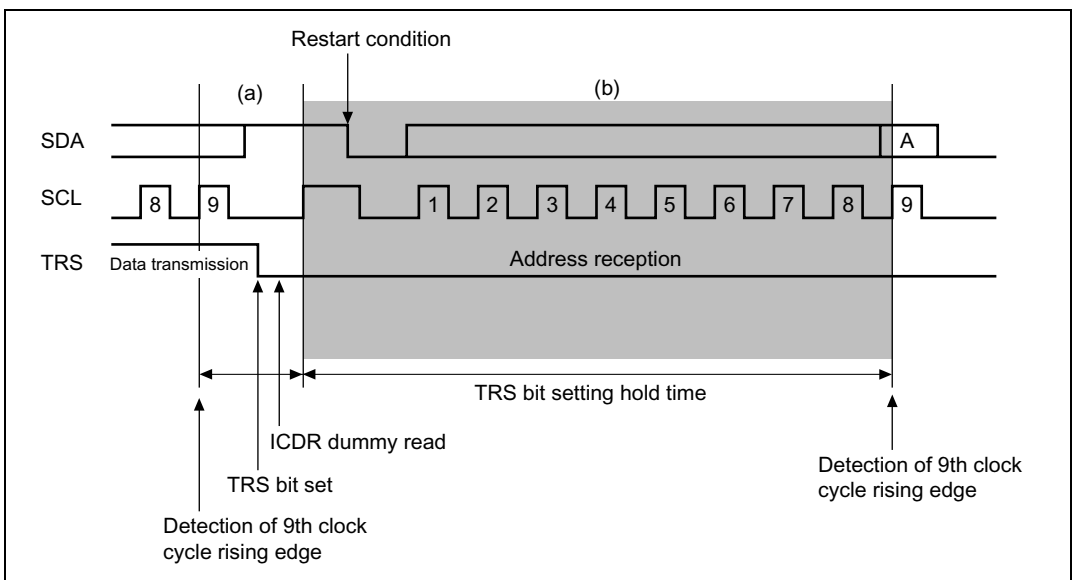

Figure 15-26 TRS Bit Setting Timing in Slave Mode

- Notes on ICDR Reads in Transmit Mode and ICDR Writes in Receive Mode

When attempting to read ICDR in the transmit mode (TRS = 1) or write to ICDR in the receive mode (TRS = 0) under certain conditions, the SCL pin may not be held low after the completion of the transmit or receive operation and a clock may not be output to the SCL bus line before the ICDR register access operation can take place properly.

When accessing ICDR, always change the setting to the transmit mode before performing a read operation, and always change the setting to the receive mode before performing a write operation.

- Notes on ACKE Bit and TRS Bit in Slave Mode

When using the I²C bus interface, if an address is received in the slave mode immediately after 1 is received as an acknowledge bit (ACKB = 1) in the transmit mode (TRS = 1), an interrupt may be generated at the rising edge of the 9th clock cycle if the address does not match.

When performing slave mode operations using the IIC bus interface module, make sure to do the following.

- (1) When a 1 is received as an acknowledge bit for the final transmit data after completing a series of transmit operations, clear the ACKE bit in the ICCR register to 0 to initialize the ACKB bit to 0.
- (2) In the slave mode, change the setting to the receive mode (TRS = 0) before the start condition is input. To ensure that the switch from the slave transmit mode to the slave receive mode is accomplished properly, end the transmission as described in figure 15-17.

- Notes on Arbitration Lost in Master Mode

The I²C bus interface recognizes the data in transmit/receive frame as an address when arbitration is lost in master mode and a transition to slave receive mode is automatically carried out.

When arbitration is lost not in the first frame but in the second frame or subsequent frame, transmit/receive data that is not an address is compared with the value set in the SAR or SARX register as an address. If the receive data matches with the address in the SAR or SARX register, the I²C bus interface erroneously recognizes that the address call has occurred. (See figure 15-27.)

In multi-master mode, a bus conflict could happen. When The I²C bus interface is operated in master mode, check the state of the AL bit in the ICSR register every time after one frame of data has been transmitted or received.

When arbitration is lost during transmitting the second frame or subsequent frame, take avoidance measures.

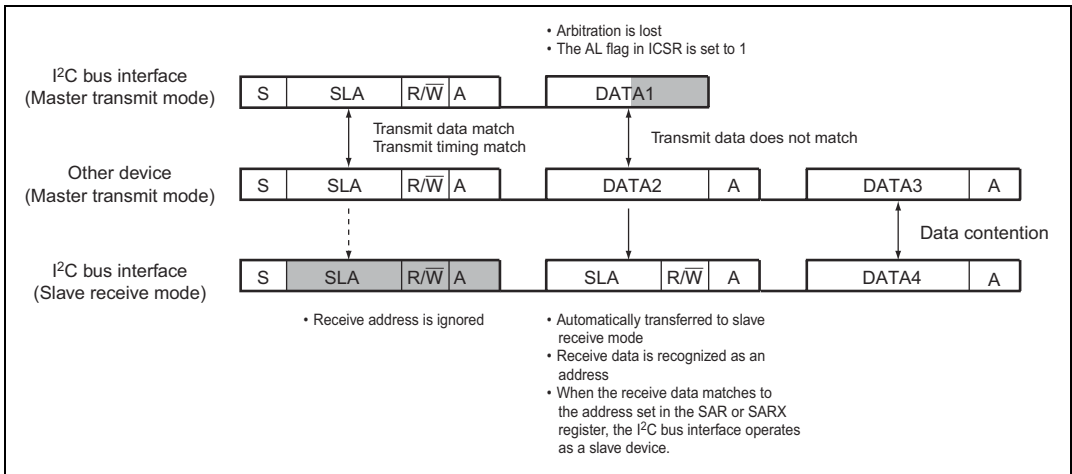

Figure 15-27 Diagram of Erroneous Operation when Arbitration is Lost

Though it is prohibited in the normal I²C protocol, the same problem may occur when the MST bit is erroneously set to 1 and a transition to master mode is occurred during data transmission or reception in slave mode. In multi-master mode, pay attention to the setting of the MST bit when a bus conflict may occur. In this case, the MST bit in the ICCR register should be set to 1 according to the order below.

- Make sure that the BBSY flag in the ICCR register is 0 and the bus is free before setting the MST bit.
- Set the MST bit to 1.
- To confirm that the bus was not entered to the busy state while the MST bit is being set, check that the BBSY flag in the ICCR register is 0 immediately after the MST bit has been set.

Note: Above restriction can be cleared by setting bits FNC1 and FNC0 in the ICXR register.

Section 16 Controller Area Network (HCAN)

Notes: The H8S/2635 Group is not equipped with a DTC.

Only a single HCAN channel, HCAN0, is implemented in the H8S/2635 Group.

16.1 Overview

The HCAN is a module for controlling a controller area network (CAN) for realtime communication in vehicular and industrial equipment systems, etc. The chip has a 2-channel on-chip HCAN module.

Reference: Bosch CAN Specification Version 2.0, 1991, Robert Bosch GmbH

16.1.1 Features

- CAN version: Bosch 2.0B active compatible
 - Communication systems:
 - NRZ (Non-Return to Zero) system (with bit-stuffing function)
 - Broadcast communication system
 - Transmission path: Bidirectional 2-wire serial communication
 - Communication speed: Max. 1 Mbps
 - Data length: 0 to 8 bytes
- Number of channel: 2 (HCAN0, HCAN1)
- Data buffers: 16 per channel (one receive-only buffer and 15 buffers settable for transmission/reception)
- Data transmission: Choice of two methods:
 - Mailbox (buffer) number order (low-to-high)
 - Message priority (identifier) high-to-low order
- Data reception: Two methods:
 - Message identifier match (transmit/receive-setting buffers)
 - Reception with message identifier masked (receive-only)
- CPU interrupts: Two interrupt vectors for 12 interrupt causes per channel:
 - Error interrupt
 - Reset processing interrupt
 - Message reception interrupt (mailbox 1 to 15)
 - Message reception interrupt (mailbox 0)
 - Message transmission interrupt

- HCAN operating modes: Support for various modes:
 - Hardware reset
 - Software reset
 - Normal status (error-active, error-passive)
 - Bus off status
 - HCAN configuration mode
 - HCAN sleep mode
 - HCAN halt mode
- Other features: DTC can be activated by message reception mailbox (HCAN mailbox 0 only)

16.1.2 Block Diagram

Figure 16-1 shows a block diagram of the HCAN.

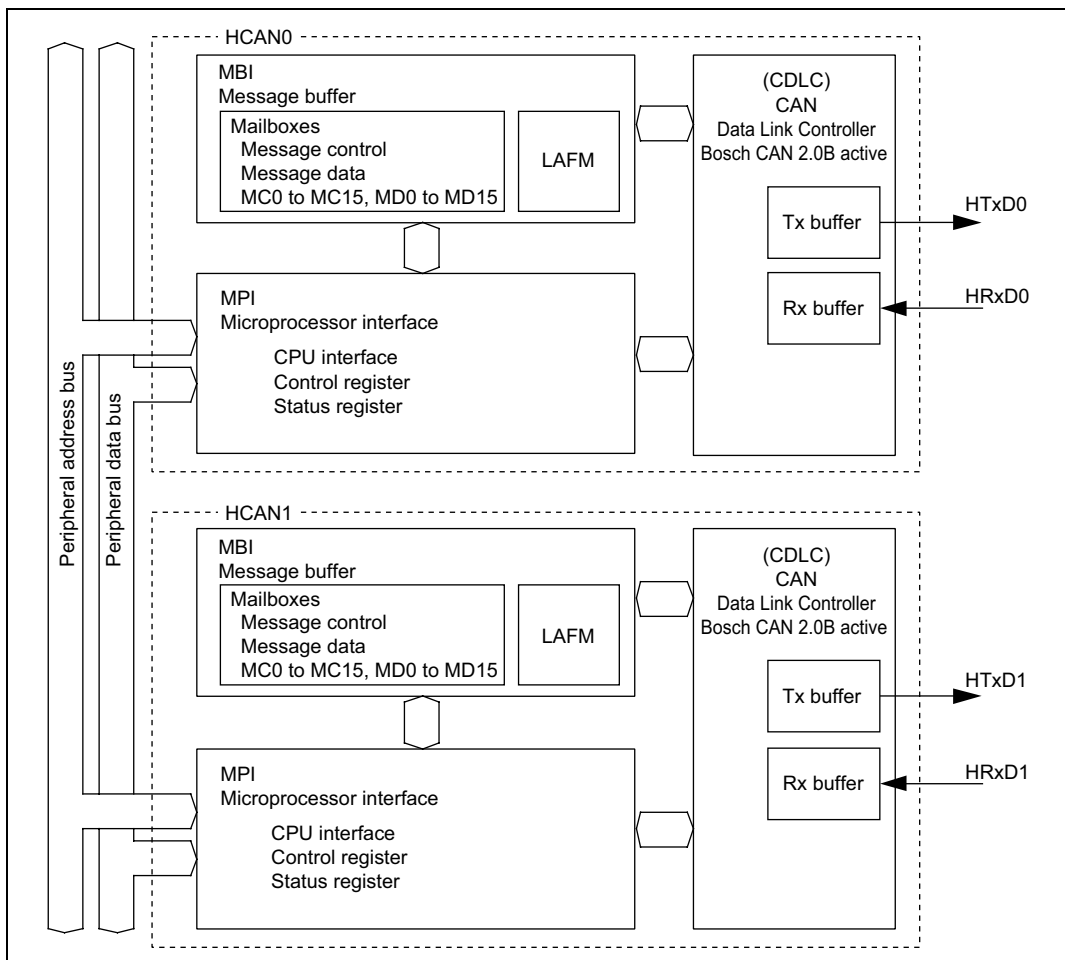

Figure 16-1 HCAN Block Diagram

Message Buffer Interface (MBI): The MBI, consisting of mailboxes and a local acceptance filter mask (LAFM), stores CAN transmit/receive messages (identifiers, data, etc.). Transmit messages are written by the CPU. For receive messages, the data received by the CDLC is stored automatically.

Microprocessor Interface (MPI): The MPI, consisting of a bus interface, control register, status register, etc., controls HCAN internal data, statuses, and so forth.

CAN Data Link Controller (CDLC): The CDLC performs transmission and reception of messages conforming to the Bosch CAN Ver. 2.0B active standard (data frames, remote frames, error frames, overload frames, inter-frame spacing), as well as CRC checking, bus arbitration, and other functions.

16.1.3 Pin Configuration

Table 16-1 shows the HCAN's pins.

When using HCAN pins, settings must be made in the HCAN configuration mode (during initialization: MCR0 = 1 and GSR3 = 1).

Table 16-1 HCAN Pins

Channel	Name	Abbreviation	Input/Output	Function
0	HCAN transmit data pin 0	HTxD0	Output	Channel 0 CAN bus transmission pin
	HCAN receive data pin 0	HRxD0	Input	Channel 0 CAN bus reception pin
1*	HCAN transmit data pin 1	HTxD1	Output	Channel 1 CAN bus transmission pin
	HCAN receive data pin 1	HRxD1	Input	Channel 1 CAN bus reception pin

Note: * The HCAN1 is not supported by the H8S/2635 and H8S/2634.

A bus driver is necessary between the pins and the CAN bus. A HA13721 compatible model is recommended.

16.1.4 Register Configuration

Table 16-2 lists the HCAN's registers.

Table 16-2 HCAN Registers

Channel	Name	Abbreviation	R/W	Initial Value	Address*1	Access Size
0	Master control register	MCR	R/W	H'01	H'F800	8 bits 16 bits
	General status register	GSR	R/W	H'0C	H'F801	8 bits
	Bit configuration register	BCR	R/W	H'0000	H'F802	8/16 bits
	Mailbox configuration register	MBCR	R/W	H'0100	H'F804	8/16 bits
	Transmit wait register	TXPR	R/W	H'0000	H'F806	8/16 bits
	Transmit wait cancel register	TXCR	R/W	H'0000	H'F808	8/16 bits
	Transmit acknowledge register	TXACK	R/W	H'0000	H'F80A	8/16 bits
	Abort acknowledge register	ABACK	R/W	H'0000	H'F80C	8/16 bits
	Receive complete register	RXPR	R/W	H'0000	H'F80E	8/16 bits
	Remote request register	RFPR	R/W	H'0000	H'F810	8/16 bits
	Interrupt register	IRR	R/W	H'0100	H'F812	8/16 bits
	Mailbox interrupt mask register	MBIMR	R/W	H'FFFF	H'F814	8/16 bits
	Interrupt mask register	IMR	R/W	H'FEFF	H'F816	8/16 bits
	Receive error counter	REC	R	H'00	H'F818	8 bits 16 bits
	Transmit error counter	TEC	R	H'00	H'F819	8 bits
	Unread message status register	UMSR	R/W	H'0000	H'F81A	8/16 bits
	Local acceptance filter mask L	LAFML	R/W	H'0000	H'F81C	8/16 bits
	Local acceptance filter mask H	LAFMH	R/W	H'0000	H'F81E	8/16 bits

Channel Name	Abbreviation	R/W	Initial Value	Address*1	Access Size	
0	Message control 0 [1:8]	MC0 [1:8]	R/W	Undefined	H'F820	8/16 bits
	Message control 1 [1:8]	MC1 [1:8]	R/W	Undefined	H'F828	8/16 bits
	Message control 2 [1:8]	MC2 [1:8]	R/W	Undefined	H'F830	8/16 bits
	Message control 3 [1:8]	MC3 [1:8]	R/W	Undefined	H'F838	8/16 bits
	Message control 4 [1:8]	MC4 [1:8]	R/W	Undefined	H'F840	8/16 bits
	Message control 5 [1:8]	MC5 [1:8]	R/W	Undefined	H'F848	8/16 bits
	Message control 6 [1:8]	MC6 [1:8]	R/W	Undefined	H'F850	8/16 bits
	Message control 7 [1:8]	MC7 [1:8]	R/W	Undefined	H'F858	8/16 bits
	Message control 8 [1:8]	MC8 [1:8]	R/W	Undefined	H'F860	8/16 bits
	Message control 9 [1:8]	MC9 [1:8]	R/W	Undefined	H'F868	8/16 bits
	Message control 10 [1:8]	MC10 [1:8]	R/W	Undefined	H'F870	8/16 bits
	Message control 11 [1:8]	MC11 [1:8]	R/W	Undefined	H'F878	8/16 bits
	Message control 12 [1:8]	MC12 [1:8]	R/W	Undefined	H'F880	8/16 bits
	Message control 13 [1:8]	MC13 [1:8]	R/W	Undefined	H'F888	8/16 bits
	Message control 14 [1:8]	MC14 [1:8]	R/W	Undefined	H'F890	8/16 bits
	Message control 15 [1:8]	MC15 [1:8]	R/W	Undefined	H'F898	8/16 bits
	Message data 0 [1:8]	MD0 [1:8]	R/W	Undefined	H'F8B0	8/16 bits
	Message data 1 [1:8]	MD1 [1:8]	R/W	Undefined	H'F8B8	8/16 bits
	Message data 2 [1:8]	MD2 [1:8]	R/W	Undefined	H'F8C0	8/16 bits
	Message data 3 [1:8]	MD3 [1:8]	R/W	Undefined	H'F8C8	8/16 bits
	Message data 4 [1:8]	MD4 [1:8]	R/W	Undefined	H'F8D0	8/16 bits
	Message data 5 [1:8]	MD5 [1:8]	R/W	Undefined	H'F8D8	8/16 bits
	Message data 6 [1:8]	MD6 [1:8]	R/W	Undefined	H'F8E0	8/16 bits
	Message data 7 [1:8]	MD7 [1:8]	R/W	Undefined	H'F8E8	8/16 bits
	Message data 8 [1:8]	MD8 [1:8]	R/W	Undefined	H'F8F0	8/16 bits
	Message data 9 [1:8]	MD9 [1:8]	R/W	Undefined	H'F8F8	8/16 bits
	Message data 10 [1:8]	MD10 [1:8]	R/W	Undefined	H'F900	8/16 bits
	Message data 11 [1:8]	MD11 [1:8]	R/W	Undefined	H'F908	8/16 bits
	Message data 12 [1:8]	MD12 [1:8]	R/W	Undefined	H'F910	8/16 bits
	Message data 13 [1:8]	MD13 [1:8]	R/W	Undefined	H'F918	8/16 bits
	Message data 14 [1:8]	MD14 [1:8]	R/W	Undefined	H'F920	8/16 bits
	Message data 15 [1:8]	MD15 [1:8]	R/W	Undefined	H'F928	8/16 bits

Channel	Name	Abbreviation	R/W	Initial Value	Address ^{*1}	Access Size
1 ^{*2}	Master control register	MCR	R/W	H'01	H'FA00	8 bits 16 bits
	General status register	GSR	R/W	H'0C	H'FA01	8 bits
	Bit configuration register	BCR	R/W	H'0000	H'FA02	8/16 bits
	Mailbox configuration register	MBCR	R/W	H'0100	H'FA04	8/16 bits
	Transmit wait register	TXPR	R/W	H'0000	H'FA06	8/16 bits
	Transmit wait cancel register	TXCR	R/W	H'0000	H'FA08	8/16 bits
	Transmit acknowledge register	TXACK	R/W	H'0000	H'FA0A	8/16 bits
	Abort acknowledge register	ABACK	R/W	H'0000	H'FA0C	8/16 bits
	Receive complete register	RXPR	R/W	H'0000	H'FA0E	8/16 bits
	Remote request register	RFPR	R/W	H'0000	H'FA10	8/16 bits
	Interrupt register	IRR	R/W	H'0100	H'FA12	8/16 bits
	Mailbox interrupt mask register	MBIMR	R/W	H'FFFF	H'FA14	8/16 bits
	Interrupt mask register	IMR	R/W	H'FEFF	H'FA16	8/16 bits
	Receive error counter	REC	R	H'00	H'FA18	8 bits 16 bits
	Transmit error counter	TEC	R	H'00	H'FA19	8 bits
	Unread message status register	UMSR	R/W	H'0000	H'FA1A	8/16 bits
	Local acceptance filter mask L	LAFML	R/W	H'0000	H'FA1C	8/16 bits
	Local acceptance filter mask H	LAFMH	R/W	H'0000	H'FA1E	8/16 bits

Channel Name	Abbreviation	R/W	Initial Value	Address ^{*1}	Access Size
1 ^{*2} Message control 0 [1:8]	MC0 [1:8]	R/W	Undefined	H'FA20	8/16 bits
Message control 1 [1:8]	MC1 [1:8]	R/W	Undefined	H'FA28	8/16 bits
Message control 2 [1:8]	MC2 [1:8]	R/W	Undefined	H'FA30	8/16 bits
Message control 3 [1:8]	MC3 [1:8]	R/W	Undefined	H'FA38	8/16 bits
Message control 4 [1:8]	MC4 [1:8]	R/W	Undefined	H'FA40	8/16 bits
Message control 5 [1:8]	MC5 [1:8]	R/W	Undefined	H'FA48	8/16 bits
Message control 6 [1:8]	MC6 [1:8]	R/W	Undefined	H'FA50	8/16 bits
Message control 7 [1:8]	MC7 [1:8]	R/W	Undefined	H'FA58	8/16 bits
Message control 8 [1:8]	MC8 [1:8]	R/W	Undefined	H'FA60	8/16 bits
Message control 9 [1:8]	MC9 [1:8]	R/W	Undefined	H'FA68	8/16 bits
Message control 10 [1:8]	MC10 [1:8]	R/W	Undefined	H'FA70	8/16 bits
Message control 11 [1:8]	MC11 [1:8]	R/W	Undefined	H'FA78	8/16 bits
Message control 12 [1:8]	MC12 [1:8]	R/W	Undefined	H'FA80	8/16 bits
Message control 13 [1:8]	MC13 [1:8]	R/W	Undefined	H'FA88	8/16 bits
Message control 14 [1:8]	MC14 [1:8]	R/W	Undefined	H'FA90	8/16 bits
Message control 15 [1:8]	MC15 [1:8]	R/W	Undefined	H'FA98	8/16 bits
Message data 0 [1:8]	MD0 [1:8]	R/W	Undefined	H'FAB0	8/16 bits
Message data 1 [1:8]	MD1 [1:8]	R/W	Undefined	H'FAB8	8/16 bits
Message data 2 [1:8]	MD2 [1:8]	R/W	Undefined	H'FAC0	8/16 bits
Message data 3 [1:8]	MD3 [1:8]	R/W	Undefined	H'FAC8	8/16 bits
Message data 4 [1:8]	MD4 [1:8]	R/W	Undefined	H'FAD0	8/16 bits
Message data 5 [1:8]	MD5 [1:8]	R/W	Undefined	H'FAD8	8/16 bits
Message data 6 [1:8]	MD6 [1:8]	R/W	Undefined	H'FAE0	8/16 bits
Message data 7 [1:8]	MD7 [1:8]	R/W	Undefined	H'FAE8	8/16 bits
Message data 8 [1:8]	MD8 [1:8]	R/W	Undefined	H'FAF0	8/16 bits
Message data 9 [1:8]	MD9 [1:8]	R/W	Undefined	H'FAF8	8/16 bits
Message data 10 [1:8]	MD10 [1:8]	R/W	Undefined	H'FB00	8/16 bits
Message data 11 [1:8]	MD11 [1:8]	R/W	Undefined	H'FB08	8/16 bits
Message data 12 [1:8]	MD12 [1:8]	R/W	Undefined	H'FB10	8/16 bits
Message data 13 [1:8]	MD13 [1:8]	R/W	Undefined	H'FB18	8/16 bits
Message data 14 [1:8]	MD14 [1:8]	R/W	Undefined	H'FB20	8/16 bits
Message data 15 [1:8]	MD15 [1:8]	R/W	Undefined	H'FB28	8/16 bits
All Module stop control register C	MSTPCRC	R/W	H'FF	H'FDEA	8/16 bits

Notes: 1. Lower 16 bits of the address.

2. The HCAN1 is not supported by the H8S/2635 and H8S/2634.

16.2 Register Descriptions

16.2.1 Master Control Register (MCR)

The master control register (MCR) is an 8-bit readable/writable register that controls the CAN interface.

MCR

Bit:	7	6	5	4	3	2	1	0
	MCR7	—	MCR5	—	—	MCR2	MCR1	MCR0
Initial value:	0	0	0	0	0	0	0	1
R/W:	R/W	R	R/W	R	R	R/W	R/W	R/W

Bit 7—HCAN Sleep Mode Release (MCR7): Enables or disables HCAN sleep mode release by bus operation.

Bit 7: MCR7	Description
0	HCAN sleep mode release by CAN bus operation disabled (Initial value)
1	HCAN sleep mode release by CAN bus operation enabled

Bit 6—Reserved: This bit always reads 0. The write value should always be 0.

Bit 5—HCAN Sleep Mode (MCR5): Enables or disables HCAN sleep mode transition.

Bit 5: MCR5	Description
0	HCAN sleep mode released (Initial value)
1	Transition to HCAN sleep mode enabled

Bits 4 and 3—Reserved: These bits always read 0. The write value should always be 0.

Bit 2—Message Transmission Method (MCR2): Selects the transmission method for transmit messages.

Bit 2: MCR2	Description
0	Transmission order determined by message identifier priority (Initial value)
1	Transmission order determined by mailbox (buffer) number priority (TXPR1 > TXPR15)

Bit 1—Halt Request (MCR1): Controls halting of the HCAN module.

Bit 1: MCR1	Description
0	HCAN normal operating mode (Initial value)
1	HCAN halt mode transition request

Bit 0—Reset Request (MCR0): Controls resetting of the HCAN module.

Bit 0: MCR0	Description
0	Normal operating mode (MCR0 = 0 and GSR3 = 0) [Setting condition] <ul style="list-style-type: none"> When 0 is written after an HCAN reset
1	HCAN reset mode transition request (Initial value)

In order for GSR3 to change from 1 to 0 after 0 is written to MCR0, time is required before the HCAN is internally reset. There is consequently a delay before GSR3 is cleared to 0 after MCR0 is cleared to 0.

16.2.2 General Status Register (GSR)

The general status register (GSR) is an 8-bit readable register that indicates the status of the CAN bus.

GSR

Bit:	7	6	5	4	3	2	1	0
	—	—	—	—	GSR3	GSR2	GSR1	GSR0
Initial value:	0	0	0	0	1	1	0	0
R/W:	R	R	R	R	R	R	R	R

Bits 7 to 4—Reserved: These bits always read 0.

Bit 3—Reset Status Bit (GSR3): Indicates whether the HCAN module is in the normal operating state or the reset state. Writes are invalid.

Bit 3: MCR3	Description
0	Normal operating state [Setting condition] <ul style="list-style-type: none"> After an HCAN internal reset
1	Configuration mode [Reset condition] <ul style="list-style-type: none"> MCR0 reset mode and sleep mode (Initial value)

Bit 2—Message Transmission Status Flag (GSR2): Flag that indicates whether the module is currently in the message transmission period. The “message transmission period” is the period from the start of message transmission (SOF) until the end of a 3-bit intermission interval after EOF (End of Frame). Writes are invalid.

Bit 2: GSR2	Description
0	Message transmission period
1	[Reset condition] (Initial value) <ul style="list-style-type: none"> Idle period

Bit 1—Transmit/Receive Warning Flag (GSR1): Flag that indicates an error warning. Writes are invalid.

Bit 1: GSR1	Description
0	[Reset condition] <ul style="list-style-type: none"> When $TEC < 96$ and $REC < 96$ or $TEC \geq 256$ (Initial value)
1	When $TEC \geq 96$ or $REC \geq 96$

Bit 0—Bus Off Flag (GSR0): Flag that indicates the bus off state. Writes are invalid.

Bit 0: GSR0	Description
0	[Reset condition] <ul style="list-style-type: none"> Recovery from bus off state (Initial value)
1	When $TEC \geq 256$ (bus off state)

16.2.3 Bit Configuration Register (BCR)

The bit configuration register (BCR) is a 16-bit readable/writable register that is used to set CAN bit timing parameters and the baud rate prescaler.

BCR

Bit:	15	14	13	12	11	10	9	8
	BCR7	BCR6	BCR5	BCR4	BCR3	BCR2	BCR1	BCR0
Initial value:	0	0	0	0	0	0	0	0
R/W:	R/W	R/W	R/W	R/W	R/W	R/W	R/W	R/W

Bit:	7	6	5	4	3	2	1	0
	BCR15	BCR14	BCR13	BCR12	BCR11	BCR10	BCR9	BCR8
Initial value:	0	0	0	0	0	0	0	0
R/W:	R/W	R/W	R/W	R/W	R/W	R/W	R/W	R/W

Bits 15 and 14—Resynchronization Jump Width (SJW): These bits set the bit synchronization range.

Bit 15: BCR7	Bit 14: BCR6	Description
0	0	Bit synchronization width = 1 time quantum (Initial value)
	1	Bit synchronization width = 2 time quanta
1	0	Bit synchronization width = 3 time quanta
	1	Bit synchronization width = 4 time quanta

Bits 13 to 8—Baud Rate Prescaler (BRP): These bits are used to set the CAN bus baud rate.

Bit 13: BCR5	Bit 12: BCR4	Bit 11: BCR3	Bit 10: BCR2	Bit 9: BCR1	Bit 8: BCR0	Description
0	0	0	0	0	0	2 × system clock (Initial value)
0	0	0	0	0	1	4 × system clock
0	0	0	0	1	0	6 × system clock
.
.
.
1	1	1	1	1	1	128 × system clock

Bit 7—Bit Sample Point (BSP): Sets the point at which data is sampled.

Bit 7: BCR15	Description
0	Bit sampling at one point (end of time segment 1 (TSEG1)) (Initial value)
1	Bit sampling at three points (end of time segment 1 (TSEG1) and preceding and following time quanta)

Bits 6 to 4—Time Segment 2 (TSEG2): These bits are used to set the segment for correcting 1-bit time error. A value from 2 to 8 can be set.

Bit 6: BCR14	Bit 5: BCR13	Bit 4: BCR12	Description
0	0	0	Setting prohibited (Initial value)
		1	TSEG2 = 2 time quanta
	1	0	TSEG2 = 3 time quanta
		1	TSEG2 = 4 time quanta
1	0	0	TSEG2 = 5 time quanta
		1	TSEG2 = 6 time quanta
	1	0	TSEG2 = 7 time quanta
		1	TSEG2 = 8 time quanta

Bits 3 to 0—Time Segment 1 (TSEG1): These bits are used to set the segment for absorbing output buffer, CAN bus, and input buffer delay. A value from 1 to 16 can be set.

Bit 3: BCR11	Bit 2: BCR10	Bit 1: BCR9	Bit 0: BCR8	Description
0	0	0	0	Setting prohibited (Initial value)
0	0	0	1	Setting prohibited
0	0	1	0	Setting prohibited
0	0	1	1	TSEG1 = 4 time quanta
0	1	0	0	TSEG1 = 5 time quanta
.
.
.
1	1	1	1	TSEG1 = 16 time quanta

16.2.4 Mailbox Configuration Register (MBCR)

The mailbox configuration register (MBCR) is a 16-bit readable/writable register that is used to set mailbox (buffer) transmission/reception.

MBCR

Bit:	15	14	13	12	11	10	9	8
	MBCR7	MBCR6	MBCR5	MBCR4	MBCR3	MBCR2	MBCR1	—
Initial value:	0	0	0	0	0	0	0	1
R/W:	R/W	R/W	R/W	R/W	R/W	R/W	R/W	R

Bit:	7	6	5	4	3	2	1	0
	MBCR15	MBCR14	MBCR13	MBCR12	MBCR11	MBCR10	MBCR9	MBCR8
Initial value:	0	0	0	0	0	0	0	0
R/W:	R/W	R/W	R/W	R/W	R/W	R/W	R/W	R/W

Bits 15 to 9 and 7 to 0—Mailbox Setting Register (MBCR7 to MBCR1, MBCR15 to MBCR8): These bits set the polarity of the corresponding mailboxes.

Bit x: MBCRx	Description
0	Corresponding mailbox is set for transmission (Initial value)
1	Corresponding mailbox is set for reception

(x = 15 to 9, 7 to 0)

Bit 8—Reserved: This bit always reads 1. The write value should always be 1.

16.2.5 Transmit Wait Register (TXPR)

The transmit wait register (TXPR) is a 16-bit readable/writable register that is used to set a transmit wait after a transmit message is stored in a mailbox (buffer) (CAN bus arbitration wait).

TXPR

Bit:	15	14	13	12	11	10	9	8
	TXPR7	TXPR6	TXPR5	TXPR4	TXPR3	TXPR2	TXPR1	—
Initial value:	0	0	0	0	0	0	0	0
R/W:	R/W	R/W	R/W	R/W	R/W	R/W	R/W	R
Bit:	7	6	5	4	3	2	1	0
	TXPR15	TXPR14	TXPR13	TXPR12	TXPR11	TXPR10	TXPR9	TXPR8
Initial value:	0	0	0	0	0	0	0	0
R/W:	R/W	R/W	R/W	R/W	R/W	R/W	R/W	R/W

Bits 15 to 9 and 7 to 0—Transmit Wait Register (TXPR7 to TXPR1, TXPR15 to TXPR8):

These bits set a transmit wait for the corresponding mailboxes.

Bit x: TXPRx	Description
0	Transmit message idle state in corresponding mailbox (Initial value) [Clearing condition] <ul style="list-style-type: none"> Message transmission completion and cancellation completion
1	Transmit message transmit wait in corresponding mailbox (CAN bus arbitration)

(x = 15 to 9, 7 to 0)

Bit 8—Reserved: This bit always reads 0. The write value should always be 0.

16.2.6 Transmit Wait Cancel Register (TXCR)

The transmit wait cancel register (TXCR) is a 16-bit readable/writable register that controls cancellation of transmit wait messages in mailboxes (buffers).

TXCR

Bit:	15	14	13	12	11	10	9	8
	TXCR7	TXCR6	TXCR5	TXCR4	TXCR3	TXCR2	TXCR1	—
Initial value:	0	0	0	0	0	0	0	0
R/W:	R/W	R/W	R/W	R/W	R/W	R/W	R/W	R

Bit:	7	6	5	4	3	2	1	0
	TXCR15	TXCR14	TXCR13	TXCR12	TXCR11	TXCR10	TXCR9	TXCR8
Initial value:	0	0	0	0	0	0	0	0
R/W:	R/W	R/W	R/W	R/W	R/W	R/W	R/W	R/W

(x = 15 to 9, 7 to 0)

Bits 15 to 9 and 7 to 0—Transmit Wait Cancel Register (TXCR7 to TXCR1, TXCR15 to TXCR8): These bits control cancellation of transmit wait messages in the corresponding HCAN mailboxes.

Bit x: TXCRx	Description
0	Transmit message cancellation idle state in corresponding mailbox (Initial value) [Clearing condition] <ul style="list-style-type: none"> Completion of TXPR clearing (when transmit message is canceled normally)
1	TXPR cleared for corresponding mailbox (transmit message cancellation)

(x = 15 to 9, 7 to 0)

Bit 8—Reserved: This bit always reads 0. The write value should always be 0.

16.2.7 Transmit Acknowledge Register (TXACK)

The transmit acknowledge register (TXACK) is a 16-bit readable/writable register containing status flags that indicate normal transmission of mailbox (buffer) transmit messages.

TXACK

Bit:	15	14	13	12	11	10	9	8
	TXACK7	TXACK6	TXACK5	TXACK4	TXACK3	TXACK2	TXACK1	—
Initial value:	0	0	0	0	0	0	0	0
R/W:	R/(W)*	R/(W)*	R/(W)*	R/(W)*	R/(W)*	R/(W)*	R/(W)*	R

Bit:	7	6	5	4	3	2	1	0
	TXACK15	TXACK14	TXACK13	TXACK12	TXACK11	TXACK10	TXACK9	TXACK8
Initial value:	0	0	0	0	0	0	0	0
R/W:	R/(W)*	R/(W)*	R/(W)*	R/(W)*	R/(W)*	R/(W)*	R/(W)*	R/(W)*

Note: * Only a write of 1 is permitted, to clear the flag.

Bits 15 to 9 and 7 to 0—Transmit Acknowledge Register (TXACK7 to TXACK1, TXACK15 to TXACK8): These bits indicate that a transmit message in the corresponding HCAN mailbox has been transmitted normally.

Bit x: TXACKx	Description
0	[Clearing condition] <ul style="list-style-type: none"> Writing 1 (Initial value)
1	Completion of message transmission for corresponding mailbox

(x = 15 to 9, 7 to 0)

Bit 8—Reserved: This bit always reads 0. The write value should always be 0.

16.2.8 Abort Acknowledge Register (ABACK)

The abort acknowledge register (ABACK) is a 16-bit readable/writable register containing status flags that indicate normal cancellation (aborting) of a mailbox (buffer) transmit messages.

ABACK

Bit:	15	14	13	12	11	10	9	8
	ABACK7	ABACK6	ABACK5	ABACK4	ABACK3	ABACK2	ABACK1	—
Initial value:	0	0	0	0	0	0	0	0
R/W:	R/(W)*	R/(W)*	R/(W)*	R/(W)*	R/(W)*	R/(W)*	R/(W)*	R

Bit:	7	6	5	4	3	2	1	0
	ABACK15	ABACK14	ABACK13	ABACK12	ABACK11	ABACK10	ABACK9	ABACK8
Initial value:	0	0	0	0	0	0	0	0
R/W:	R/(W)*	R/(W)*	R/(W)*	R/(W)*	R/(W)*	R/(W)*	R/(W)*	R/(W)*

Note: * Only a write of 1 is permitted, to clear the flag.

Bits 15 to 9 and 7 to 0—Abort Acknowledge Register (ABACK7 to ABACK1, ABACK15 to ABACK8): These bits indicate that a transmit message in the corresponding mailbox has been canceled (aborted) normally.

Bit x: ABACKx	Description
0	[Clearing condition] <ul style="list-style-type: none"> Writing 1 (Initial value)
1	Completion of transmit message cancellation for corresponding mailbox (x = 15 to 9, 7 to 0)

Bit 8—Reserved: This bit always reads 0. The write value should always be 0.

16.2.9 Receive Complete Register (RXPR)

The receive complete register (RXPR) is a 16-bit readable/writable register containing status flags that indicate normal reception of messages (data frame or remote frame) in mailboxes (buffers).

In the case of remote frame reception, the corresponding remote request register (RFPR) is also set simultaneously.

RXPR

Bit:	15	14	13	12	11	10	9	8
	RXPR7	RXPR6	RXPR5	RXPR4	RXPR3	RXPR2	RXPR1	RXPR0
Initial value:	0	0	0	0	0	0	0	0
R/W:	R/(W)*	R/(W)*	R/(W)*	R/(W)*	R/(W)*	R/(W)*	R/(W)*	R/(W)*

Bit:	7	6	5	4	3	2	1	0
	RXPR15	RXPR14	RXPR13	RXPR12	RXPR11	RXPR10	RXPR9	RXPR8
Initial value:	0	0	0	0	0	0	0	0
R/W:	R/(W)*	R/(W)*	R/(W)*	R/(W)*	R/(W)*	R/(W)*	R/(W)*	R/(W)*

Note: * Only a write of 1 is permitted, to clear the flag.

Bits 15 to 0—Receive Complete Register (RXPR7 to RXPR0, RXPR15 to RXPR8): These bits indicate that a receive message has been received normally in the corresponding mailbox.

Bit x: RXPRx	Description
0	[Clearing condition] <ul style="list-style-type: none"> Writing 1 (Initial value)
1	Completion of message (data frame or remote frame) reception in corresponding mailbox

(x = 15 to 0)

16.2.10 Remote Request Register (RFPR)

The remote request register (RFPR) is a 16-bit readable/writable register containing status flags that indicate normal reception of remote frames in mailboxes (buffers). When a bit in this register is set, the corresponding reception complete bit is set simultaneously.

RFPR

Bit:	15	14	13	12	11	10	9	8
	RFPR7	RFPR6	RFPR5	RFPR4	RFPR3	RFPR2	RFPR1	RFPR0
Initial value:	0	0	0	0	0	0	0	0
R/W:	R/(W)*	R/(W)*	R/(W)*	R/(W)*	R/(W)*	R/(W)*	R/(W)*	R/(W)*

Bit:	7	6	5	4	3	2	1	0
	RFPR15	RFPR14	RFPR13	RFPR12	RFPR11	RFPR10	RFPR9	RFPR8
Initial value:	0	0	0	0	0	0	0	0
R/W:	R/(W)*	R/(W)*	R/(W)*	R/(W)*	R/(W)*	R/(W)*	R/(W)*	R/(W)*

Note: * Only a write of 1 is permitted, to clear the flag.

Bits 15 to 0—Remote Request Register (RFPR7 to RFPR0, RFPR15 to RFPR8): These bits indicate that a remote frame has been received normally in the corresponding mailbox.

Bit x: RFPRx	Description
0	[Clearing condition] <ul style="list-style-type: none"> Writing 1 (Initial value)
1	Completion of remote frame reception in corresponding mailbox

(x = 15 to 0)

16.2.11 Interrupt Register (IRR)

The interrupt register (IRR) is a 16-bit readable/writable register containing status flags for the various interrupt sources.

IRR

Bit:	15	14	13	12	11	10	9	8
	IRR7	IRR6	IRR5	IRR4	IRR3	IRR2	IRR1	IRR0
Initial value:	0	0	0	0	0	0	0	1
R/W:	R/(W)*	R/(W)*	R/(W)*	R/(W)*	R/(W)*	R	R	R/(W)*

Bit:	7	6	5	4	3	2	1	0
	—	—	—	IRR12	—	—	IRR9	IRR8
Initial value:	0	0	0	0	0	0	0	0
R/W:	—	—	—	R/(W)*	—	—	R	R/(W)*

Note: * Only a write of 1 is permitted, to clear the flag.

Bit 15—Overload Frame Interrupt Flag (IRR7): Status flag indicating that the HCAN has transmitted an overload frame.

Bit 15: IRR7	Description
0	[Clearing condition] <ul style="list-style-type: none"> Writing 1 (Initial value)
1	Overload frame transmission [Setting condition] <ul style="list-style-type: none"> When overload frame is transmitted

Bit 14—Bus Off Interrupt Flag (IRR6): Status flag indicating the bus off state caused by the transmit error counter.

Bit 14: IRR6	Description
0	[Clearing condition] <ul style="list-style-type: none">Writing 1 (Initial value)
1	Bus off state caused by transmit error [Setting condition] <ul style="list-style-type: none">When $TEC \geq 256$

Bit 13—Error Passive Interrupt Flag (IRR5): Status flag indicating the error passive state caused by the transmit/receive error counter.

Bit 13: IRR5	Description
0	[Clearing condition] <ul style="list-style-type: none">Writing 1 (Initial value)
1	Error passive state caused by transmit/receive error [Setting condition] <ul style="list-style-type: none">When $TEC \geq 128$ or $REC \geq 128$

Bit 12—Receive Overload Warning Interrupt Flag (IRR4): Status flag indicating the error warning state caused by the receive error counter.

Bit 12: IRR4	Description
0	[Clearing condition] <ul style="list-style-type: none">Writing 1 (Initial value)
1	Error warning state caused by receive error [Setting condition] <ul style="list-style-type: none">When $REC \geq 96$

Bit 11—Transmit Overload Warning Interrupt Flag (IRR3): Status flag indicating the error warning state caused by the transmit error counter.

Bit 11: IRR3	Description
0	[Clearing condition] <ul style="list-style-type: none"> Writing 1 (Initial value)
1	Error warning state caused by transmit error <ul style="list-style-type: none"> When $TEC \geq 96$

Bit 10—Remote Frame Request Interrupt Flag (IRR2): Status flag indicating that a remote frame has been received in a mailbox (buffer).

Bit 10: IRR2	Description
0	[Clearing condition] <ul style="list-style-type: none"> Clearing of all bits in RFPR (remote request register) of mailbox for which receive interrupt requests are enabled by MBIMR (Initial value)
1	Remote frame received and stored in mailbox <ul style="list-style-type: none"> When remote frame reception is completed, when corresponding $MBIMR = 0$

Bit 9—Receive Message Interrupt Flag (IRR1): Status flag indicating that a mailbox (buffer) receive message has been received normally.

Bit 9: IRR1	Description
0	[Clearing condition] <ul style="list-style-type: none"> Clearing of all bits in RXPR (receive complete register) of mailbox for which receive interrupt requests are enabled by MBIMR (Initial value)
1	Data frame or remote frame received and stored in mailbox <ul style="list-style-type: none"> When data frame or remote frame reception is completed, when corresponding $MBIMR = 0$

Bit 8—Reset Interrupt Flag (IRR0): Status flag indicating that the HCAN module has been reset. This bit cannot be masked in the interrupt mask register (IMR). If this bit is not cleared after reset input or recovery from software standby mode, interrupt handling will be performed as soon as interrupts are enabled by the interrupt controller.

Bit 8: IRR0	Description
0	[Clearing condition] <ul style="list-style-type: none">• Writing 1
1	Hardware reset (HCAN module stop*, software standby) (Initial value) [Setting condition] <ul style="list-style-type: none">• When reset processing is completed after a hardware reset (HCAN module stop*, software standby)

Note: * After reset or hardware standby release, the module stop bit is initialized to 1, and so the HCAN enters the module stop state.

Bits 7 to 5, 3, and 2—Reserved: These bits always read 0. The write value should always be 0.

Bit 4—Bus Operation Interrupt Flag (IRR12): Status flag indicating detection of a dominant bit due to bus operation when the HCAN module is in HCAN sleep mode.

Bit 4: IRR12	Description
0	CAN bus idle state (Initial value) [Clearing condition] <ul style="list-style-type: none">• Writing 1
1	CAN bus operation in HCAN sleep mode [Setting condition] <ul style="list-style-type: none">• Bus operation (dominant bit detection) in HCAN sleep mode

Bit 1—Unread Interrupt Flag (IRR9): Status flag indicating that a receive message has been overwritten while still unread.

Bit 1: IRR9	Description
0	[Clearing condition] <ul style="list-style-type: none"> Clearing of all bits in UMSR (unread message status register) (Initial value)
1	Unread message overwrite [Setting condition] <ul style="list-style-type: none"> When UMSR (unread message status register) is set

Bit 0—Mailbox Empty Interrupt Flag (IRR8): Status flag indicating that the next transmit message can be stored in the mailbox.

Bit 0: IRR8	Description
0	[Clearing condition] <ul style="list-style-type: none"> Writing 1 (Initial value)
1	Transmit message has been transmitted or aborted, and new message can be stored [Setting condition] <ul style="list-style-type: none"> When TXPR (transmit wait register) is cleared by completion of transmission or completion of transmission abort

16.2.12 Mailbox Interrupt Mask Register (MBIMR)

The mailbox interrupt mask register (MBIMR) is a 16-bit readable/writable register containing flags that enable or disable individual mailbox (buffer) interrupt requests.

MBIMR

Bit:	15	14	13	12	11	10	9	8
	MBIMR7	MBIMR6	MBIMR5	MBIMR4	MBIMR3	MBIMR2	MBIMR1	MBIMR0
Initial value:	1	1	1	1	1	1	1	1
R/W:	R/W	R/W	R/W	R/W	R/W	R/W	R/W	R/W
Bit:	7	6	5	4	3	2	1	0
	MBIMR15	MBIMR14	MBIMR13	MBIMR12	MBIMR11	MBIMR10	MBIMR9	MBIMR8
Initial value:	1	1	1	1	1	1	1	1
R/W:	R/W	R/W	R/W	R/W	R/W	R/W	R/W	R/W

Bits 15 to 0—Mailbox Interrupt Mask (MBIMRx): Flags that enable or disable individual mailbox interrupt requests.

Bit x: MBIMRx	Description
0	[Transmitting] <ul style="list-style-type: none"> Interrupt request to CPU due to TXPR clearing [Receiving] <ul style="list-style-type: none"> Interrupt request to CPU due to RXPR setting
1	Interrupt requests to CPU disabled (Initial value)

(x = 15 to 0)

16.2.13 Interrupt Mask Register (IMR)

The interrupt mask register (IMR) is a 16-bit readable/writable register containing flags that enable or disable requests by individual interrupt sources.

IMR

Bit:	15	14	13	12	11	10	9	8
	IMR7	IMR6	IMR5	IMR4	IMR3	IMR2	IMR1	—
Initial value:	1	1	1	1	1	1	1	0
R/W:	R/W	R/W	R/W	R/W	R/W	R/W	R/W	R

Bit:	7	6	5	4	3	2	1	0
	—	—	—	IMR12	—	—	IMR9	IMR8
Initial value:	1	1	1	1	1	1	1	1
R/W:	R	R	R	R/W	R	R	R/W	R/W

Bit 15—Overload Frame/Bus Off Recovery Interrupt Mask (IMR7): Enables or disables overload frame/bus off recovery interrupt requests.

Bit 15: IMR7	Description
0	Overload frame/bus off recovery interrupt request (OVR0) to CPU by IRR7 enabled
1	Overload frame/bus off recovery interrupt request (OVR0) to CPU by IRR7 disabled (Initial value)

Bit 14—Bus Off Interrupt Mask (IMR6): Enables or disables bus off interrupt requests caused by the transmit error counter.

Bit 14: IMR6	Description
0	Bus off interrupt request (ERS0) to CPU by IRR6 enabled
1	Bus off interrupt request (ERS0) to CPU by IRR6 disabled (Initial value)

Bit 13—Error Passive Interrupt Mask (IMR5): Enables or disables error passive interrupt requests caused by the transmit/receive error counter.

Bit 13: IMR5	Description
0	Error passive interrupt request (ERS0) to CPU by IRR5 enabled
1	Error passive interrupt request (ERS0) to CPU by IRR5 disabled (Initial value)

Bit 12—Receive Overload Warning Interrupt Mask (IMR4): Enables or disables error warning interrupt requests caused by the receive error counter.

Bit 12: IMR4	Description
0	REC error warning interrupt request (OVR0) to CPU by IRR4 enabled
1	REC error warning interrupt request (OVR0) to CPU by IRR4 disabled (Initial value)

Bit 11—Transmit Overload Warning Interrupt Mask (IMR3): Enables or disables error warning interrupt requests caused by the transmit error counter.

Bit 11: IMR3	Description
0	TEC error warning interrupt request (OVR0) to CPU by IRR3 enabled
1	TEC error warning interrupt request (OVR0) to CPU by IRR3 disabled (Initial value)

Bit 10—Remote Frame Request Interrupt Mask (IMR2): Enables or disables remote frame reception interrupt requests.

Bit 10: IMR2	Description
0	Remote frame reception interrupt request (OVR0) to CPU by IRR2 enabled
1	Remote frame reception interrupt request (OVR0) to CPU by IRR2 disabled (Initial value)

Bit 9—Receive Message Interrupt Mask (IMR1): Enables or disables message reception interrupt requests.

Bit 9: IMR1	Description
0	Message reception interrupt request (RM1) to CPU by IRR1 enabled
1	Message reception interrupt request (RM1) to CPU by IRR1 disabled (Initial value)

Bit 8—Reserved: The reset flag cannot be masked. This bit always reads 0. The write value should always be 0.

Bits 7 to 5, 3, and 2—Reserved: These bits always read 1. The write value should always be 1.

Bit 4—Bus Operation Interrupt Mask (IMR12): Enables or disables interrupt requests due to bus operation in sleep mode.

Bit 4: IMR12	Description
0	Bus operation interrupt request (OVR0) to CPU by IRR12 enabled
1	Bus operation interrupt request (OVR0) to CPU by IRR12 disabled (Initial value)

Bit 1—Unread Interrupt Mask (IMR9): Enables or disables unread receive message overwrite interrupt requests.

Bit 1: IMR9	Description
0	Unread message overwrite interrupt request (OVR0) to CPU by IRR9 enabled
1	Unread message overwrite interrupt request (OVR0) to CPU by IRR9 disabled (Initial value)

Bit 0—Mailbox Empty Interrupt Mask (IMR8): Enables or disables mailbox empty interrupt requests.

Bit 0: IMR8	Description
0	Mailbox empty interrupt request (SLE0) to CPU by IRR8 enabled
1	Mailbox empty interrupt request (SLE0) to CPU by IRR8 disabled (Initial value)

16.2.14 Receive Error Counter (REC)

The receive error counter (REC) is an 8-bit read-only register that functions as a counter indicating the number of receive message errors on the CAN bus. The count value is stipulated in the CAN protocol.

REC

Bit:	7	6	5	4	3	2	1	0
Initial value:	0	0	0	0	0	0	0	0
R/W:	R	R	R	R	R	R	R	R

16.2.15 Transmit Error Counter (TEC)

The transmit error counter (TEC) is an 8-bit read-only register that functions as a counter indicating the number of transmit message errors on the CAN bus. The count value is stipulated in the CAN protocol.

TEC

Bit:	7	6	5	4	3	2	1	0
Initial value:	0	0	0	0	0	0	0	0
R/W:	R	R	R	R	R	R	R	R

16.2.16 Unread Message Status Register (UMSR)

The unread message status register (UMSR) is a 16-bit readable/writable register containing status flags that indicate, for individual mailboxes (buffers), that a received message has been overwritten by a new receive message before being read. When a message is overwritten by a new receive message, the old data is lost.

UMSR

Bit:	15	14	13	12	11	10	9	8
	UMSR7	UMSR6	UMSR5	UMSR4	UMSR3	UMSR2	UMSR1	UMSR0
Initial value:	0	0	0	0	0	0	0	0
R/W:	R/(W)*	R/(W)*	R/(W)*	R/(W)*	R/(W)*	R/(W)*	R/(W)*	R/(W)*
Bit:	7	6	5	4	3	2	1	0
	UMSR15	UMSR14	UMSR13	UMSR12	UMSR11	UMSR10	UMSR9	UMSR8
Initial value:	0	0	0	0	0	0	0	0
R/W:	R/(W)*	R/(W)*	R/(W)*	R/(W)*	R/(W)*	R/(W)*	R/(W)*	R/(W)*

Note: * Only 1 can be written, to clear the flag to 0.

Bits 15 to 0—Unread Message Status Flags (UMSRx): Status flags indicating that an unread receive message has been overwritten.

Bit x: UMSRx	Description
0	[Clearing condition] <ul style="list-style-type: none"> Writing 1 (Initial value)
1	Unread receive message is overwritten by a new message [Setting condition] <ul style="list-style-type: none"> When a new message is received before RXPR is cleared

16.2.17 Local Acceptance Filter Masks (LAFML, LAFMH)

The local acceptance filter masks (LAFML, LAFMH) are 16-bit readable/writable registers that filter receive messages to be stored in the receive-only mailbox (MC0, MD0) according to the identifier. In these registers, consist of LAFMH15: MSB to LAFMH5: LSB are 11 standard/extended identifier bits, and LAFMH1: MSB to LAFML0: LSB are 18 extended identifier bits.

LAFML

Bit:	15	14	13	12	11	10	9	8
	LAFML7	LAFML6	LAFML5	LAFML4	LAFML3	LAFML2	LAFML1	LAFML0
Initial value:	0	0	0	0	0	0	0	0
R/W:	R/W	R/W	R/W	R/W	R/W	R/W	R/W	R/W

Bit:	7	6	5	4	3	2	1	0
	LAFML15	LAFML14	LAFML13	LAFML12	LAFML11	LAFML10	LAFML9	LAFML8
Initial value:	0	0	0	0	0	0	0	0
R/W:	R/W	R/W	R/W	R/W	R/W	R/W	R/W	R/W

LAFMH

Bit:	15	14	13	12	11	10	9	8
	LAFMH7	LAFMH6	LAFMH5	—	—	—	LAFMH1	LAFMH0
Initial value:	0	0	0	0	0	0	0	0
R/W:	R/W	R/W	R/W	R	R	R	R/W	R/W

Bit:	7	6	5	4	3	2	1	0
	LAFMH15	LAFMH14	LAFMH13	LAFMH12	LAFMH11	LAFMH10	LAFMH9	LAFMH8
Initial value:	0	0	0	0	0	0	0	0
R/W:	R/W	R/W	R/W	R/W	R/W	R/W	R/W	R/W

LAFMH Bits 7 to 0 and 15 to 13—11-Bit Identifier Filter (LAFMH7 to LAFMH5, LAFMH15 to LAFMH8): Filter mask bits for the first 11 bits of the receive message identifier (for both standard and extended identifiers).

Bit x: LAFMHx	Description
0	Stored in MC0 and MD0 (receive-only mailbox) depending on bit match between MC0 message identifier and receive message identifier (Initial value)
1	Stored in MC0 and MD0 (receive-only mailbox) regardless of bit match between MC0 message identifier and receive message identifier

(x = 15 to 0)

LAFMH Bits 12 to 10—Reserved: These bits always read 0. The write value should always be 0.

LAFMH Bits 9 and 8, LAFML Bits 15 to 0—18-Bit Identifier Filter (LAFMH1, LAFMH0, LAFML7 to LAFML0, LAFML15 to LAFML8): Filter mask bits for the 18 bits of the receive message identifier (extended).

Bit x: LAFMHx LAFMLx	Description
0	Stored in MC0 (receive-only mailbox) depending on bit match between MC0 message identifier and receive message identifier (Initial value)
1	Stored in MC0 (receive-only mailbox) regardless of bit match between MC0 message identifier and receive message identifier

(x = 15 to 0)

16.2.18 Message Control (MC0 to MC15)

The message control register sets (MC0 to MC15) consist of eight 8-bit readable/writable registers (MCx[1] to MCx[8]). The HCAN has 16 sets of these registers (MC0 to MC15).

The initial value of these registers is undefined, so they must be initialized (by writing 0 or 1).

MCx [1]

Bit:	7	6	5	4	3	2	1	0
	—	—	—	—	DLC3	DLC2	DLC1	DLC0
Initial value:	*	*	*	*	*	*	*	*
R/W:	R/W	R/W	R/W	R/W	R/W	R/W	R/W	R/W

MCx [2]

Bit:	7	6	5	4	3	2	1	0
	—	—	—	—	—	—	—	—
Initial value:	*	*	*	*	*	*	*	*
R/W:	R/W	R/W	R/W	R/W	R/W	R/W	R/W	R/W

MCx [3]

Bit:	7	6	5	4	3	2	1	0
	—	—	—	—	—	—	—	—
Initial value:	*	*	*	*	*	*	*	*
R/W:	R/W	R/W	R/W	R/W	R/W	R/W	R/W	R/W

MCx [4]

Bit:	7	6	5	4	3	2	1	0
	—	—	—	—	—	—	—	—
Initial value:	*	*	*	*	*	*	*	*
R/W:	R/W	R/W	R/W	R/W	R/W	R/W	R/W	R/W

*:Undefined

MCx [5]

Bit:	7	6	5	4	3	2	1	0
	STD_ID2	STD_ID1	STD_ID0	RTR	IDE	—	EXD_ID17	EXD_ID16
Initial value:	*	*	*	*	*	*	*	*
R/W:	R/W	R/W	R/W	R/W	R/W	R/W	R/W	R/W

MCx [6]

Bit:	7	6	5	4	3	2	1	0
	STD_ID10	STD_ID9	STD_ID8	STD_ID7	STD_ID6	STD_ID5	STD_ID4	STD_ID3
Initial value:	*	*	*	*	*	*	*	*
R/W:	R/W	R/W	R/W	R/W	R/W	R/W	R/W	R/W

MCx [7]

Bit:	7	6	5	4	3	2	1	0
	EXD_ID7	EXD_ID6	EXD_ID5	EXD_ID4	EXD_ID3	EXD_ID2	EXD_ID1	EXD_ID0
Initial value:	*	*	*	*	*	*	*	*
R/W:	R/W	R/W	R/W	R/W	R/W	R/W	R/W	R/W

MCx [8]

Bit:	7	6	5	4	3	2	1	0
	EXD_ID15	EXD_ID14	EXD_ID13	EXD_ID12	EXD_ID11	EXD_ID10	EXD_ID9	EXD_ID8
Initial value:	*	*	*	*	*	*	*	*
R/W:	R/W	R/W	R/W	R/W	R/W	R/W	R/W	R/W

*:Undefined
(x = 15 to 0)

MCx[1] Bits 7 to 4—Reserved: The initial value of these bits is undefined; they must be initialized (by writing 0 or 1).

MCx[1] Bits 3 to 0—Data Length Code (DLC): These bits indicate the required length of data frames and remote frames.

Bit 3: DLC3	Bit 2: DLC2	Bit 1: DLC1	Bit 0: DLC0	Description
0	0	0	0	Data length = 0 bytes
			1	Data length = 1 byte
		1	0	Data length = 2 bytes
			1	Data length = 3 bytes
	1	0	0	Data length = 4 bytes
			1	Data length = 5 bytes
		1	0	Data length = 6 bytes
			1	Data length = 7 bytes
1	0/1	0/1	0/1	Data length = 8 bytes

MCx[2] Bits 7 to 0—Reserved: The initial value of these bits is undefined; they must be initialized (by writing 0 or 1).

MCx[3] Bits 7 to 0—Reserved: The initial value of these bits is undefined; they must be initialized (by writing 0 or 1).

MCx[4] Bits 7 to 0—Reserved: The initial value of these bits is undefined; they must be initialized (by writing 0 or 1).

MCx[6] Bits 7 to 0—Standard Identifier (STD_ID10 to STD_ID3)

MCx[5] Bits 7 to 5—Standard Identifier (STD_ID2 to STD_ID0)

These bits set the identifier (standard identifier) of data frames and remote frames.

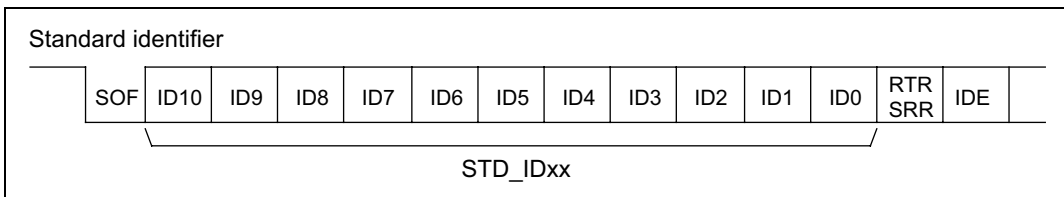

Figure 16-2 Standard identifier

MCx[5] Bit 4—Remote Transmission Request (RTR): Used to distinguish between data frames and remote frames.

Bit 4: RTR	Description
0	Data frame
1	Remote frame

MCx[5] Bit 3—Identifier Extension (IDE): Used to distinguish between the standard format and extended format of data frames and remote frames.

Bit 3: IDE	Description
0	Standard format
1	Extended format

MCx[5] Bit 2—Reserved: The initial value of this bit is undefined; it must be initialized (by writing 0 or 1).

MCx[5] Bits 1 and 0—Extended Identifier (EXD_ID17, EXD_ID16)

MCx[8] Bits 7 to 0—Extended Identifier (EXD_ID15 to EXD_ID8)

MCx[7] Bits 7 to 0—Extended Identifier (EXD_ID7 to EXD_ID0)

These bits set the identifier (extended identifier) of data frames and remote frames.

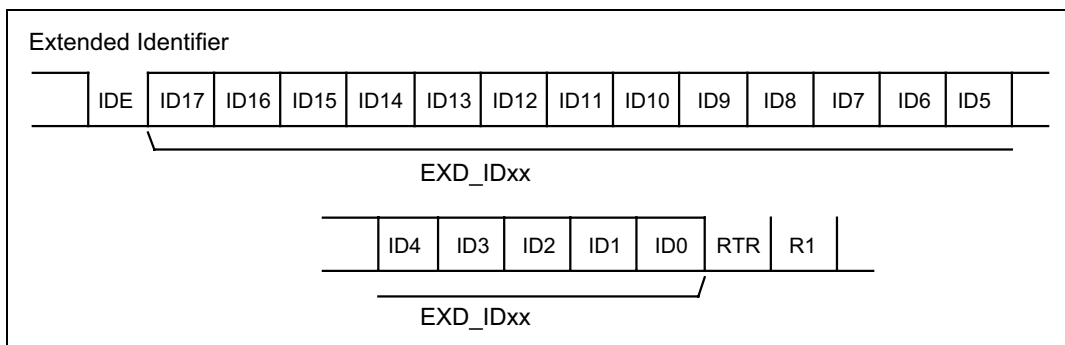

Figure 16-3 Extended identifier

16.2.19 Message Data (MD0 to MD15)

The message data register sets (MD0 to MD15) consist of eight 8-bit readable/writable registers (MDx[1] to MDx[8]). The HCAN has 16 sets of these registers (MD0 to MD15).

The initial value of these registers is undefined, so they must be initialized (by writing 0 or 1).

MDx [1]

Bit:	7	6	5	4	3	2	1	0
	<input type="checkbox"/>	<input type="checkbox"/>	<input type="checkbox"/>	<input type="checkbox"/>	<input type="checkbox"/>	<input type="checkbox"/>	<input type="checkbox"/>	<input type="checkbox"/>
Initial value:	*	*	*	*	*	*	*	*
R/W:	R/W	R/W	R/W	R/W	R/W	R/W	R/W	R/W

MDx [2]

Bit:	7	6	5	4	3	2	1	0
	<input type="checkbox"/>	<input type="checkbox"/>	<input type="checkbox"/>	<input type="checkbox"/>	<input type="checkbox"/>	<input type="checkbox"/>	<input type="checkbox"/>	<input type="checkbox"/>
Initial value:	*	*	*	*	*	*	*	*
R/W:	R/W	R/W	R/W	R/W	R/W	R/W	R/W	R/W

MDx [3]

Bit:	7	6	5	4	3	2	1	0
	<input type="checkbox"/>	<input type="checkbox"/>	<input type="checkbox"/>	<input type="checkbox"/>	<input type="checkbox"/>	<input type="checkbox"/>	<input type="checkbox"/>	<input type="checkbox"/>
Initial value:	*	*	*	*	*	*	*	*
R/W:	R/W	R/W	R/W	R/W	R/W	R/W	R/W	R/W

MDx [4]

Bit:	7	6	5	4	3	2	1	0
	<input type="checkbox"/>	<input type="checkbox"/>	<input type="checkbox"/>	<input type="checkbox"/>	<input type="checkbox"/>	<input type="checkbox"/>	<input type="checkbox"/>	<input type="checkbox"/>
Initial value:	*	*	*	*	*	*	*	*
R/W:	R/W	R/W	R/W	R/W	R/W	R/W	R/W	R/W

MDx [5]

Bit:	7	6	5	4	3	2	1	0
	<input type="checkbox"/>	<input type="checkbox"/>	<input type="checkbox"/>	<input type="checkbox"/>	<input type="checkbox"/>	<input type="checkbox"/>	<input type="checkbox"/>	<input type="checkbox"/>
Initial value:	*	*	*	*	*	*	*	*
R/W:	R/W	R/W	R/W	R/W	R/W	R/W	R/W	R/W

MDx [6]

Bit:	7	6	5	4	3	2	1	0
	<input type="checkbox"/>	<input type="checkbox"/>	<input type="checkbox"/>	<input type="checkbox"/>	<input type="checkbox"/>	<input type="checkbox"/>	<input type="checkbox"/>	<input type="checkbox"/>
Initial value:	*	*	*	*	*	*	*	*
R/W:	R/W	R/W	R/W	R/W	R/W	R/W	R/W	R/W

MDx [7]

Bit:	7	6	5	4	3	2	1	0
	<input type="checkbox"/>	<input type="checkbox"/>	<input type="checkbox"/>	<input type="checkbox"/>	<input type="checkbox"/>	<input type="checkbox"/>	<input type="checkbox"/>	<input type="checkbox"/>
Initial value:	*	*	*	*	*	*	*	*
R/W:	R/W	R/W	R/W	R/W	R/W	R/W	R/W	R/W

MDx [8]

Bit:	7	6	5	4	3	2	1	0
	<input type="checkbox"/>	<input type="checkbox"/>	<input type="checkbox"/>	<input type="checkbox"/>	<input type="checkbox"/>	<input type="checkbox"/>	<input type="checkbox"/>	<input type="checkbox"/>
Initial value:	*	*	*	*	*	*	*	*
R/W:	R/W	R/W	R/W	R/W	R/W	R/W	R/W	R/W

*:Undefined
(x = 0 to 15)

16.2.20 Module Stop Control Register C (MSTPCRC)

Bit:	7	6	5	4	3	2	1	0
	MSTPC7	MSTPC6	MSTPC5	MSTPC4	MSTPC3	MSTPC2*	MSTPC1	MSTPC0
Initial value:	1	1	1	1	1	1	1	1
R/W:	R/W	R/W	R/W	R/W	R/W	R/W	R/W	R/W

Note: * The MSTPC2 is not available and is reserved in the H8S/2635 and H8S/2634.

MSTPCRC is an 8-bit readable/writable register that performs module stop mode control.

When the MSTPC3 and MSTPC2 bits are set to 1, HCAN0 and 1 operation is stopped at the end of the bus cycle, and module stop mode is entered. Register read/write accesses are not possible in module stop mode. For details, see section 23A.5, 23B.5, Module Stop Mode.

MSTPCRC is initialized to H'FF by a reset, and in hardware standby mode. It is not initialized in software standby mode.

Bit 3—Module Stop (MSTPC3): Specifies the HCAN module stop mode.

Bit 3: MSTPC3	Description
0	HCAN0 module stop mode is cleared
1	HCAN0 module stop mode is set (Initial value)

Bit 2—Module Stop (MSTPC2)*: Specifies the HCAN module stop mode.

Note: * The MSTPC2 is not available and is reserved in the H8S/2635 and H8S/2634.

Bit 2: MSTPC2	Description
0	HCAN1 module stop mode is cleared
1	HCAN1 module stop mode is set (Initial value)

16.3 Operation

This LSI device is equipped with 2-channel HCAN modules, which are controlled independently. Both modules have identical specifications, and they are controlled in the same manner.

16.3.1 Hardware and Software Resets

The HCAN can be reset by a hardware reset or software reset.

Hardware Reset (HCAN Module Stop, Reset*, Hardware*/Software Standby): Initialization is performed by automatic setting of the MCR reset request bit (MCR0) in MCR and the reset state bit (GSR3) in GSR within the HCAN (hardware reset). At the same time, all internal registers are initialized. However mailbox contents are retained. A flowchart of this reset is shown in figure 16-4.

Note: * In a reset and in hardware standby mode, the module stop bit is initialized to 1 and the HCAN enters the module stop state.

Software Reset (Write to MCR0): In normal operation initialization is performed by setting the MCR reset request bit (MCR0) in MCR (Software reset). With this kind of reset, if the CAN controller is performing a communication operation (transmission or reception), the initialization state is not entered until the message has been completed. During initialization, the reset state bit (GSR3) in GSR is set. In this kind of initialization, the error counters (TEC and REC) are initialized but other registers and RAM (mailboxes) are not. A flowchart of this reset is shown in figure 16-5.

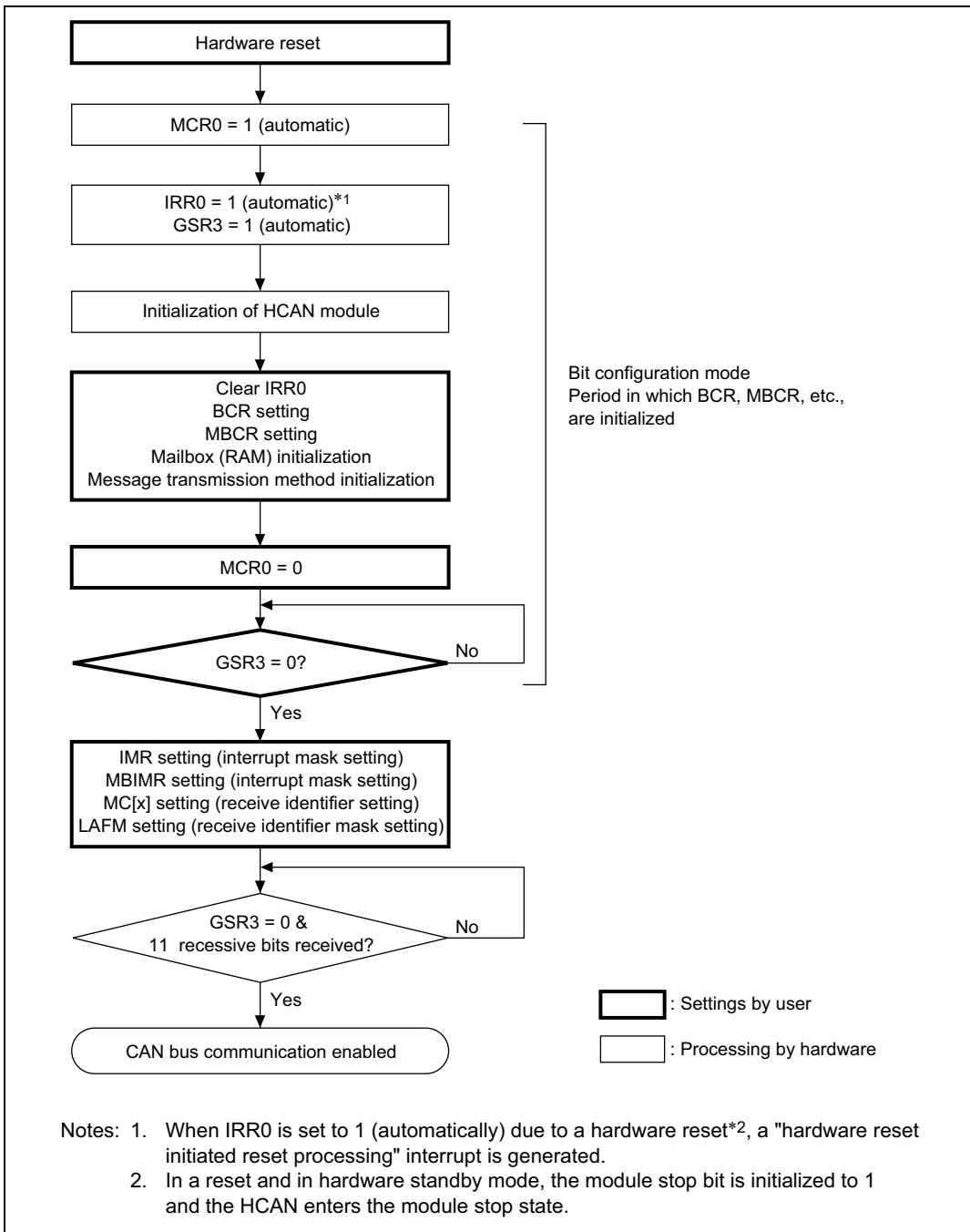

Figure 16-4 Hardware Reset Flowchart

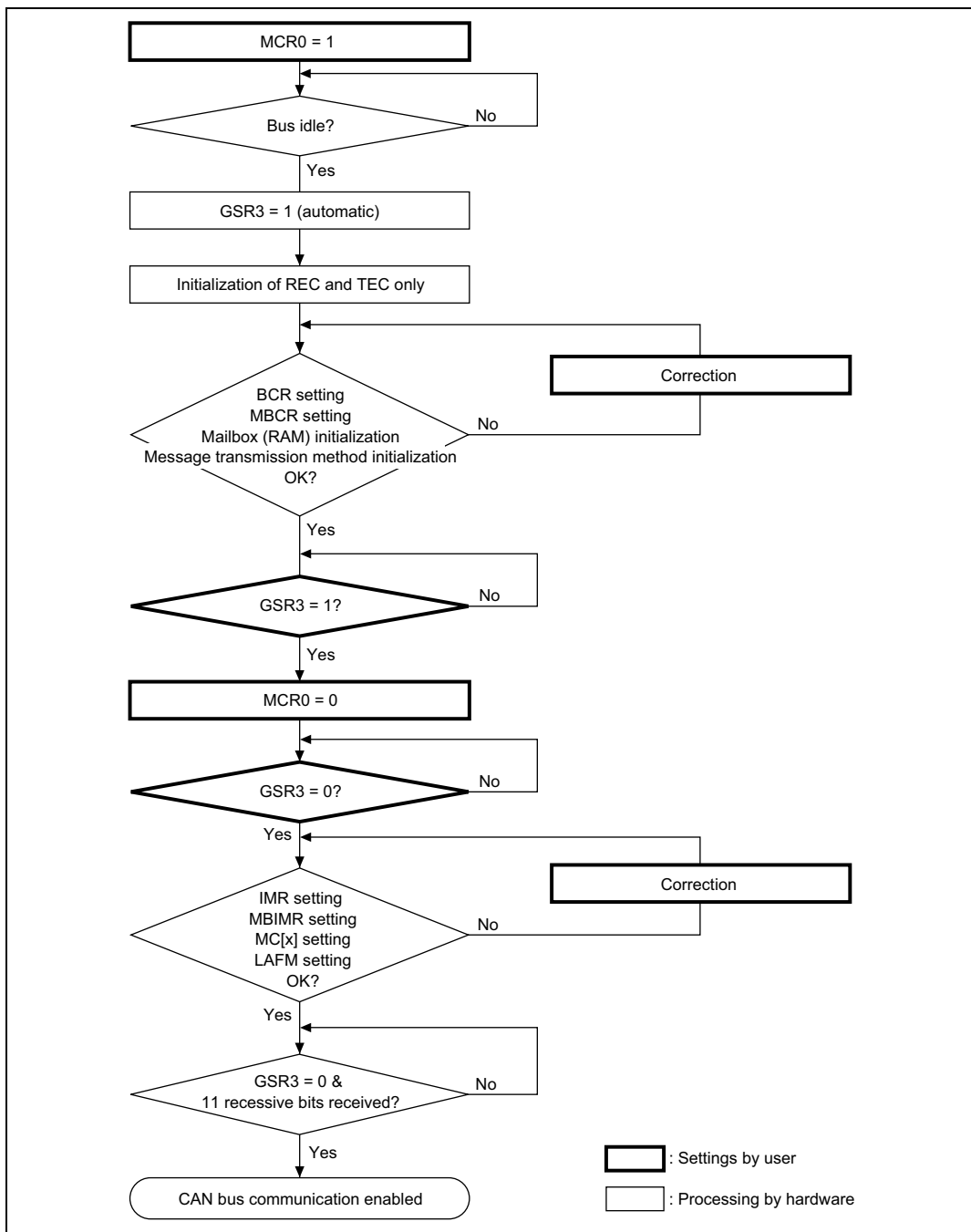

Figure 16-5 Software Reset Flowchart

16.3.2 Initialization after Hardware Reset

After a hardware reset, the following initialization processing should be carried out:

- Clearing of IRR0 bit in interrupt register (IRR)
- Bit rate setting
- Mailbox transmit/receive settings
- Mailbox (RAM) initialization
- Message transmission method setting

These initial settings must be made while the HCAN is in bit configuration mode. Configuration mode is a state in which the reset request bit (MCR0) in the master control register (MCR) is 1 and the reset status bit in the general status register (GSR) is also 1 (GSR3 = 1). Configuration mode is exited by clearing the reset request bit in MCR to 0; when MCR0 is cleared to 0, the HCAN automatically clears the reset state bit (GSR3) in the general status register (GSR). The power-up sequence then begins, and communication with the CAN bus is possible as soon as the sequence ends. The power-up sequence consists of the detection of 11 consecutive recessive bits.

IRR0 Clearing: The reset interrupt flag (IRR0) is always set after a reset or recovery from software standby mode. As an HCAN interrupt is initiated immediately when interrupts are enabled, IRR0 should be cleared.

Bit Rate and Bit Timing Settings: As bit rate settings, a baud rate setting and bit timing setting must be made each time a CAN node begins communication. The baud rate and bit timing settings are made in the bit configuration register (BCR).

a. Note

BCR can be written to at all times, but should only be modified in configuration mode.

Settings should be made so that all CAN controllers connected to the CAN bus have the same baud rate and bit width.

Limits for the settable variables (TSEG1, TSEG2, BRP, sample point, and SJW) are shown in table 16-3.

Table 16-3 BCR Register Value Setting Ranges

Name	Abbreviation	Bits	Initial Value	Min. Value	Max. Value
Time segment 1	TSEG1	4	0	3	15
Time segment 2	TSEG2	3	0	1	7
Baud rate prescaler	BRP	6	0	0	63
Sample point	SAM	1	0	0	1
Synchronization jump width	SJW	2	0	1	3

b. Value Setting Ranges

- The minimum value of SJW is stipulated in the CAN specifications.

$$3 \geq \text{SJW} \geq 0$$

- The minimum value of TSEG1 is stipulated in the CAN specifications.

$$\text{TSEG1} > \text{TSEG2}$$

- The minimum value of TSEG2 is stipulated in the CAN specifications.

$$\text{TSEG2} \geq \text{SJW}$$

The following formula is used to calculate the baud rate.

$$\text{Bit rate} = \frac{f_{\text{CLK}}}{2 \square (\text{BRP} + 1) \square (3 + \text{TSEG1} + \text{TSEG2})} \text{ [b/s]}$$

Note: $f_{\text{CLK}} = \phi$ (system clock)

The BCR value are used for BRP, TSEG1, and TSEG2.

Example: With a 1 Mb/s baud rate and a 20 MHz input clock:

$$1 \text{ Mb/s} = \frac{20 \text{ MHz}}{2 \square (0 + 1) \square (3 + 4 + 3)}$$

Item	Set Values	Actual Values
f_{CLK}	20 MHz	—
BRP	0 (B'000000)	System clock \times 2
TSEG1	4 (B'0100)	5TQ
TSEG2	3 (B'011)	4TQ

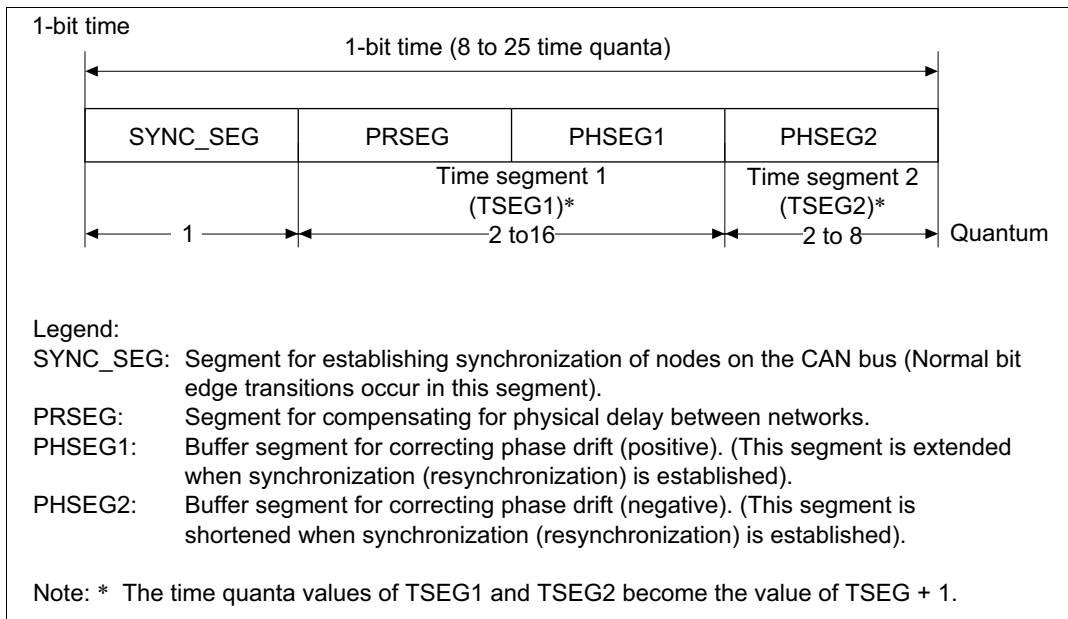

Figure 16-6 Detailed Description of One Bit

HCAN bit rate calculation:

$$\text{Bit rate} = \frac{f_{CLK}}{2 \square (\text{BRP} + 1) \square (3 + \text{TSEG1} + \text{TSEG2})}$$

f_{CLK} : peripheral clock (ϕ)

Note: The BCR values are used for BRP, TSEG1, and TSEG2.

BCR Setting Constraints

$$\text{TSEG1} > \text{TSEG2} \geq \text{SJW} \quad (\text{SJW} = 0 \text{ to } 3)$$

These constraints allow the setting range shown in table 16-4 for TSEG1 and TSEG2 in BCR.

Table 16-4 Setting Range for TSEG1 and TSEG2 in BCR

		TSEG2 (BCR [14:12])						
		001	010	011	100	101	110	111
TSEG1 (BCR [11:8])	0011	No	Yes	No	No	No	No	No
	0100	Yes*	Yes	Yes	No	No	No	No
	0101	Yes*	Yes	Yes	Yes	No	No	No
	0110	Yes*	Yes	Yes	Yes	Yes	No	No
	0111	Yes*	Yes	Yes	Yes	Yes	Yes	No
	1000	Yes*	Yes	Yes	Yes	Yes	Yes	Yes
	1001	Yes*	Yes	Yes	Yes	Yes	Yes	Yes
	1010	Yes*	Yes	Yes	Yes	Yes	Yes	Yes
	1011	Yes*	Yes	Yes	Yes	Yes	Yes	Yes
	1100	Yes*	Yes	Yes	Yes	Yes	Yes	Yes
	1101	Yes*	Yes	Yes	Yes	Yes	Yes	Yes
	1110	Yes*	Yes	Yes	Yes	Yes	Yes	Yes
1111	Yes*	Yes	Yes	Yes	Yes	Yes	Yes	

Note: * Setting is enabled except when BRP [13:8] = B'000000.

Mailbox Transmit/Receive Settings: HCAN0, 1 each have 16 mailboxes. Mailbox 0 is receive-only, while mailboxes 1 to 15 can be set for transmission or reception. Mailboxes that can be set for transmission or reception must be designated either for transmission use or for reception use before communication begins. The Initial status of mailboxes 1 to 15 is for transmission (while mailbox 0 is for reception only). Mailbox transmit/receive settings are not initialized by a software reset.

- Setting for transmission

Transmit mailbox setting (mailboxes 1 to 15)

Clearing a corresponding mailbox in the mailbox configuration register (MBCR) to 0 designates the specified mailbox for transmission use. After a reset, mailboxes are initialized for transmission use, so this setting is not necessary.

- Setting for reception

Transmit/receive mailbox setting (mailboxes 1 to 15)

Setting a bit to 1 in the mailbox configuration register (MBCR) designates the corresponding mailbox for reception use. When setting mailboxes for reception, to improve message transmission efficiency, high-priority messages should be set in low-to-high mailbox order (priority order: mailbox 1 > mailbox 15).

- Receive-only mailbox (mailbox 0)

No setting is necessary, as this mailbox is always used for reception.

Mailbox (Message Control/Data (MCx[x], MDx[x]) Initial Settings: After power is supplied, all registers and RAM (message control/data, control registers, status registers, etc.) are initialized. Message control/data (MCx[x], MDx[x]) only are in RAM, and so their values are undefined. Initial values must therefore be set in all the mailboxes (by writing 0s or 1s).

Setting the Message Transmission Method: Either of the following message transmission methods can be selected with the message transmission method bit (MCR2) in the master control register (MCR):

- a. Transmission order determined by message identifier priority
- b. Transmission order determined by mailbox number priority

When a is selected, if a number of messages are designated as waiting for transmission (TXPR = 1), the message with the highest priority set in the message identifier (MCx[5] to MCx[8]) is stored in the transmit buffer. CAN bus arbitration is then carried out for the message in the transmit buffer, and message transmission is performed when the transmission right is acquired. When the TXPR bit is set, internal arbitration is performed again, and the highest-priority message is found and stored in the transmit buffer.

When b is selected, if a number of messages are designated as waiting for transmission (TXPR = 1), messages are stored in the transmit buffer in low-to-high mailbox order (priority order: mailbox 1 > mailbox 15). CAN bus arbitration is then carried out for the messages in the transmit buffer, and message transmission is performed when the bus is acquired.

16.3.3 Transmit Mode

Message transmission is performed using mailboxes 1 to 15. The transmission procedure is described below, and a transmission flowchart is shown in figure 16-6.

Initialization (after hardware reset only)

- a. Clearing of IRR0 bit in interrupt register (IRR)
- b. Bit rate settings
- c. Mailbox transmit/receive settings
- d. Mailbox (RAM) initialization
- e. Message transmission method setting

Interrupt and transmit data settings

- a. CPU interrupt source setting
- b. Arbitration field setting
- c. Control field setting
- d. Data field setting

Message transmission and interrupts

- a. Message transmission wait
- b. Message transmission completion and interrupt
- c. Message transmission cancellation
- d. Message retransmission

Initialization (After Hardware Reset Only): These settings should be made while the HCAN is in bit configuration mode.

- IRR0 clearing

The reset interrupt flag (IRR0) is always set after a reset or recovery from software standby mode. As an HCAN interrupt is initiated immediately when interrupts are enabled, IRR0 should be cleared.

- Bit rate settings

Set values relating to the CAN bus communication speed and resynchronization. Refer to Bit Rate and Bit Timing Settings in 16.3.2, Initialization after Hardware Reset, for details.

- Mailbox transmit/receive settings

Mailbox transmit/receive settings should be made in advance. A total of 30 mailbox can be set for transmission or reception (mailboxes 1 to 15 in HCAN0 and HCAN1). To set a mailbox for transmission, clear the corresponding bit to 0 in the mailbox configuration register (MBCR). Refer to Mailbox Transmit/Receive Settings in 16.3.2, Initialization after Hardware Reset, for details.

- Mailbox (RAM) initialization

As message control/data registers (MCx[x], MDx[x]) are configured in RAM, their initial values after powering on are undefined, and so bit initialization is necessary. Write 0s or 1s to the mailboxes. See Mailbox (Message Control/Data (MCx[x], MDx[x]) Initial Setting in 16.3.2, Initialization after a Hardware Reset, for details.

- Message transmission method setting

Set the transmission method for mailboxes designated for transmission. The following two transmission methods can be used. Refer to Message Transmission Method Setting in 16.3.2, Initialization after Hardware Reset, for details.

- a. Transmission order determined by message identifier priority
- b. Transmission order determined by mailbox number priority

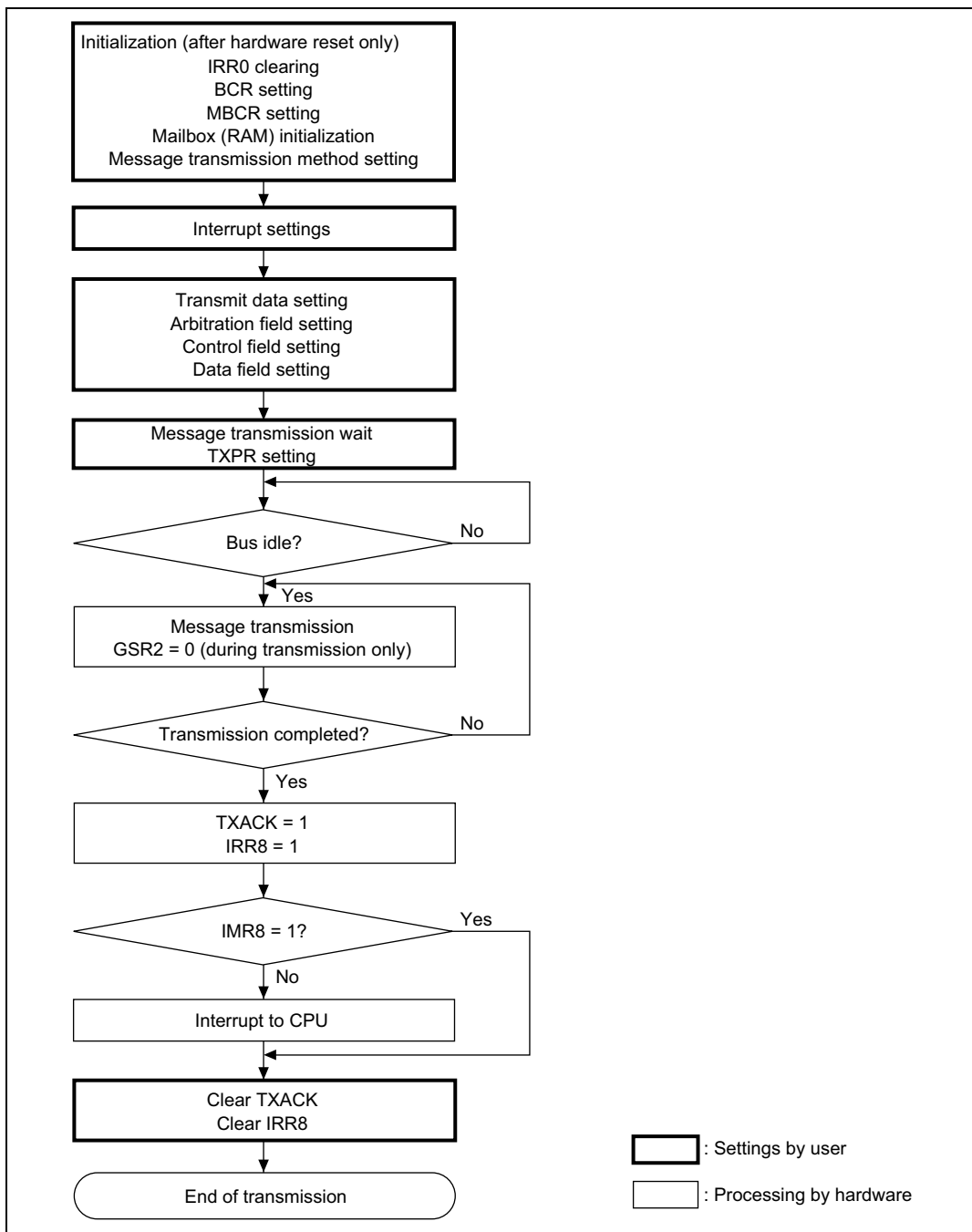

Figure 16-7 Transmission Flowchart

Interrupt and Transmit Data Settings: When mailbox initialization is finished, CPU interrupt source settings and data settings must be made. Interrupt source settings are made in the mailbox interrupt register (MBIMR) and interrupt mask register (IMR), while transmit data settings are made by writing the necessary data from the arbitration field, control field, and data field, described below, in the corresponding message control (MCx[1] to MCx[8]) and message data (MDx[1] to MDx[8]).

- CPU interrupt source setting
Transmission acknowledge and transmission abort acknowledge interrupts can be masked for individual mailboxes in the mailbox interrupt mask register (MBIMR). Interrupt register (IRR) interrupts can be masked in the interrupt mask register (IMR).
- Arbitration field setting
In the arbitration field, the 11-bit identifier (STD_ID0 to STD_ID10) and RTR bit (standard format) or 29-bit identifier (STD_ID0 to STD_ID10, EXT_ID0 to EXT_ID17) and IDE, RTR bit (extended format) are set. The registers to be set are MCx[5] to MCx[8].
- Control field setting
In the control field, the byte length of the data to be transmitted is set in DLC0 to DLC3. The register to be set is MCx[1].
- Data field setting
In the data field, the data to be transmitted is set in byte units in the range of 0 to 8 bytes. The registers to be set are MDx[1] to MDx[8].

The number of bytes in the data actually transmitted depends on the data length code (DLC) in the control field. If a value exceeding the value set in DLC is set in the data field, only the number of bytes set in DLC will actually be transmitted.

Message Transmission and Interrupts:

- Message transmission wait
If message transmission is to be performed after completion of the message control (MCx[1] to MCx[8]) and message data (MDx[1] to MDx[8]).settings, transmission is started by setting the corresponding mailbox transmit wait bit (TXPR1 to TXPR15) to 1 in the transmit wait register (TXPR). The following two transmission methods can be used:
 - a. Transmission order determined by message identifier priority
 - b. Transmission order determined by mailbox number priority

When a is selected, if a number of messages are designated as waiting for transmission (TXPR = 1), messages are stored in the transmit buffer in low-to-high mailbox order (priority order: mailbox 1 > mailbox 15). CAN bus arbitration is then carried out for the messages in the transmit buffer, and message transmission is performed when the bus is acquired.

When b is selected, if a number of messages are designated as waiting for transmission (TXPR = 1), the message with the highest priority set in the message identifier (MCx[5] to MCx[8]) is stored in the transmit buffer. CAN bus arbitration is then carried out for the message in the transmit buffer, and message transmission is performed when the transmission right is acquired. When the TXPR bit is set, internal arbitration is performed again, the highest-priority message is found and stored in the transmit buffer, CAN bus arbitration is carried out in the same way, and message transmission is performed when the transmission right is acquired.

- Message transmission completion and interrupt

When a message is transmitted error-free using the above procedure, the corresponding acknowledge bit (TXACK1 to TXACK15) in the transmit acknowledge register (TXACK) and transmit wait bit (TXPR1 to TXPR15) in the transmit wait register (TXPR) are automatically initialized. Also, if the corresponding bit (MBIMR1 to MBIMR15) in the mailbox interrupt mask register (MBIMR) and the mailbox empty interrupt bit (IRR8) in the interrupt mask register (IMR) are set to the interrupt enable state at the same time, an interrupt can be sent to the CPU.

- Message transmission cancellation

Transmission cancellation can be specified for a message stored in a mailbox as a transmit wait message. A transmit wait message is canceled by setting the bit for the corresponding mailbox (TXCR1 to TXCR15) to 1 in the transmit cancel register (TXCR). When cancellation is executed, the transmit wait register (TXPR) is automatically reset, and the corresponding bit is set to 1 in the abort acknowledge register (ABACK). An interrupt can be requested. Also, if the mailbox empty interrupt (IRR8) is enabled for the bits (MBIMR1 to MBIMR15) corresponding to the mailbox interrupt mask register (MBIMR) and interrupt mask register (IMR), interrupts may be sent to the CPU.

However, a transmit wait message cannot be canceled at the following times:

- a. During internal arbitration or CAN bus arbitration
- b. During data frame or remote frame transmission

Also, transmission cannot be canceled by clearing the transmit wait register (TXPR). Figure 16-5 shows a flowchart of transmit message cancellation.

- Message retransmission

If transmission of a transmit message is aborted in the following cases, the message is retransmitted automatically:

- CAN bus arbitration failure (failure to acquire the bus)
- Error during transmission (bit error, stuff error, CRC error, frame error, ACK error)

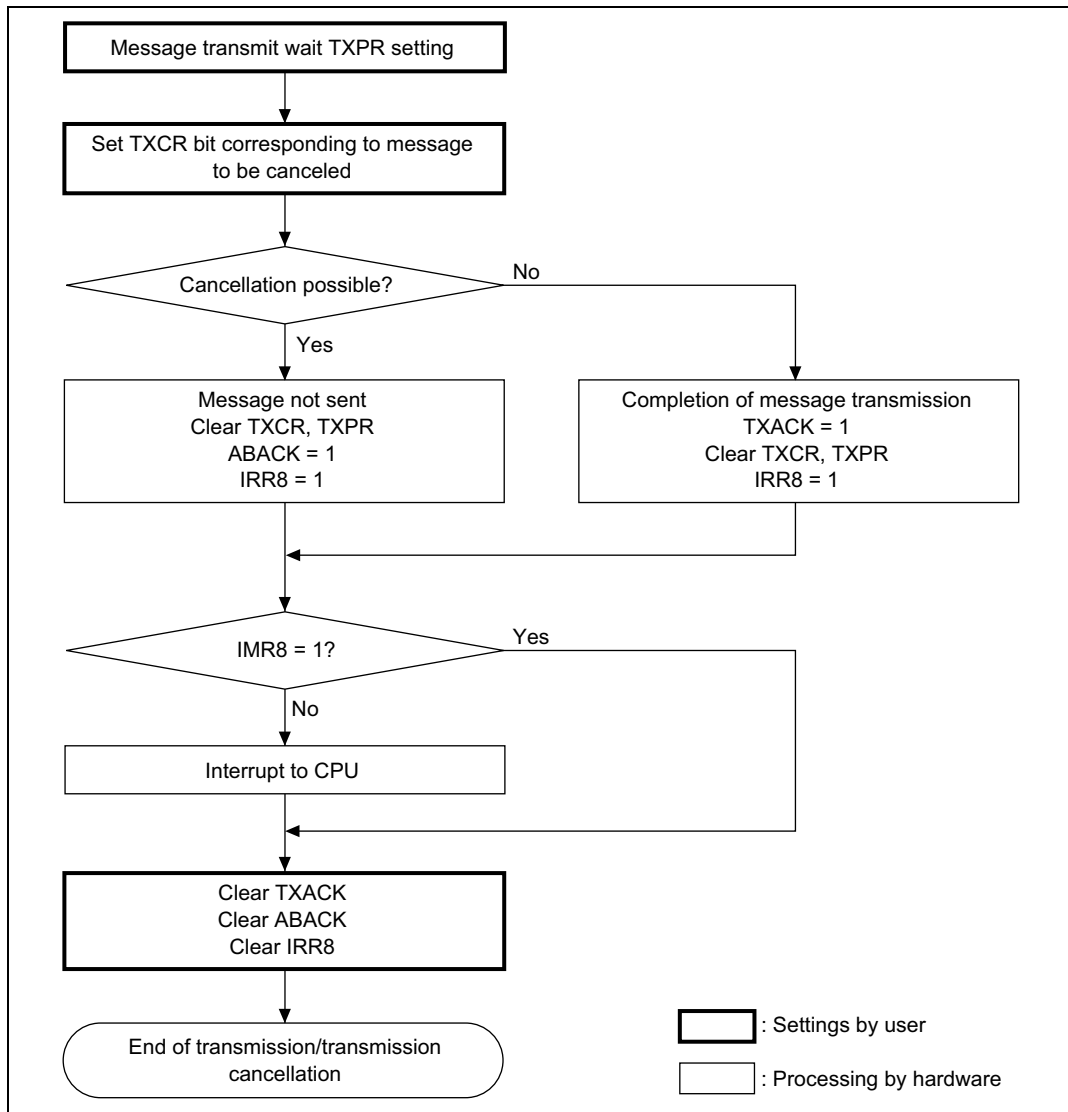

Figure 16-8 Transmit Message Cancellation Flowchart

16.3.4 Receive Mode

Message reception is performed using mailboxes 0 and 1 to 15. The reception procedure is described below, and a reception flowchart is shown in figure 16-9.

Initialization (after hardware reset only)

- a. Clearing of IRR0 bit in interrupt register (IRR)
- b. Bit rate settings
- c. Mailbox transmit/receive settings
- d. Mailbox (RAM) initialization

Interrupt and receive message settings

- a. CPU interrupt source setting
- b. Arbitration field setting
- c. Local acceptance filter mask (LAFM) settings

Message reception and interrupts

- a. Message reception CRC check
- b. Data frame reception
- c. Remote frame reception
- d. Unread message reception

Initialization (After Hardware Reset Only): These settings should be made while the HCAN is in bit configuration mode.

- IRR0 clearing

The reset interrupt flag (IRR0) is always set after a reset or recovery from software standby mode. As an HCAN interrupt is initiated immediately when interrupts are enabled, IRR0 should be cleared.

- Bit rate settings

Set values relating to the CAN bus communication speed and resynchronization. Refer to Bit Rate and Bit Timing Settings in 16.3.2, Initialization after Hardware Reset, for details.

- Mailbox transmit/receive settings

Each channel has one receive-only mailbox (mailbox 0) plus 15 mailboxes that can be set for reception. Thus a total of 32 mailboxes can be used for reception. To set a mailbox for reception, set the corresponding bit to 1 in the mailbox configuration register (MBCR). The initial setting for mailboxes is 0, designating transmission use. Refer to Mailbox Transmit/Receive Settings in 16.3.2, Initialization after Hardware Reset, for details.

- Mailbox (RAM) initialization

As message control/data registers (MCx[x], MDx[x]) are configured in RAM, their initial values after powering on are undefined, and so bit initialization is necessary. Write 0s or 1s to the mailboxes. See Mailbox (Message Control/Data (MCx[x], MDx[x]) Initial Setting in 16.3.2, Initialization after a Hardware Reset, for details.

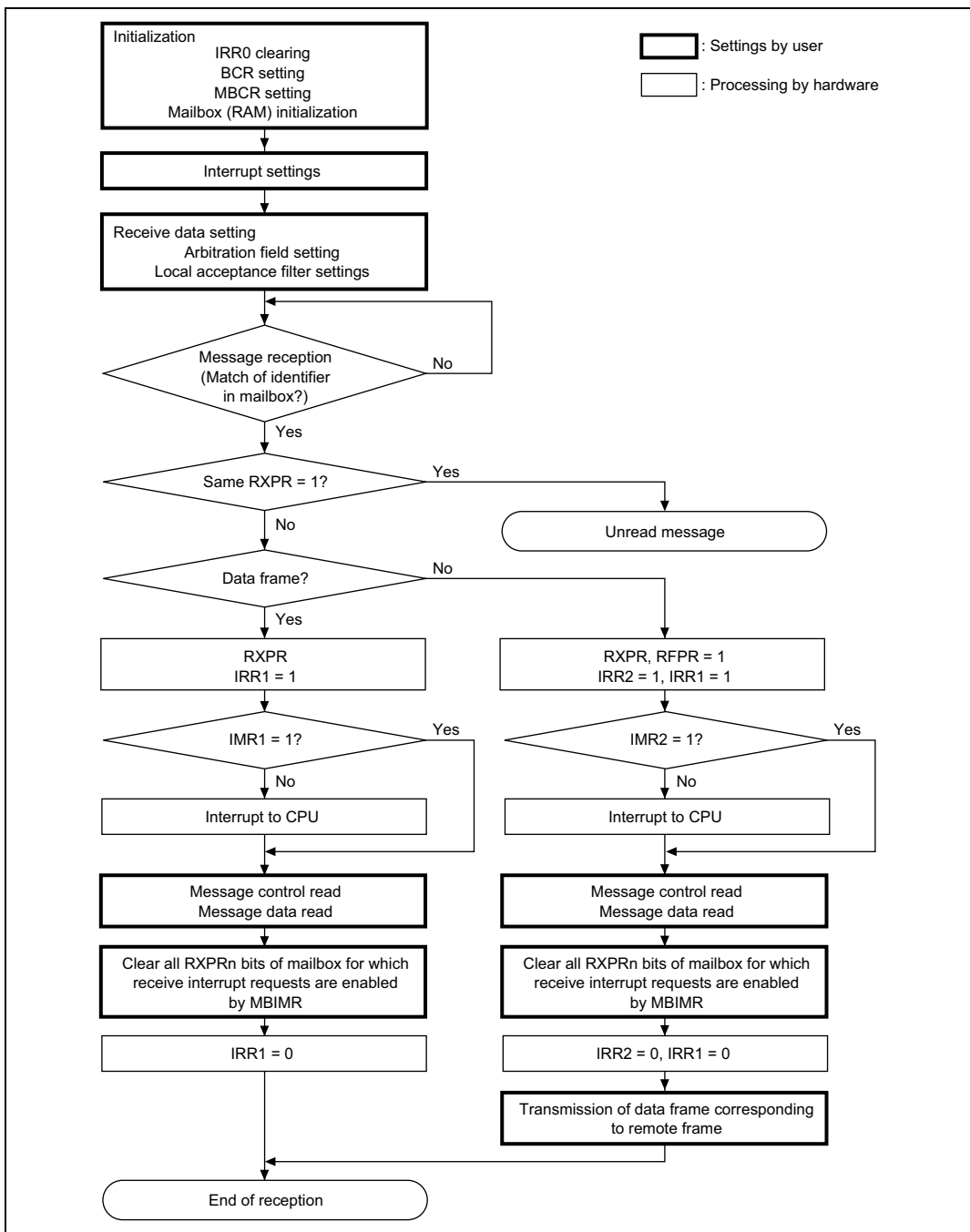

Figure 16-9 Reception Flowchart

Interrupt and Receive Message Settings: When mailbox initialization is finished, CPU interrupt source settings and receive message specifications must be made. Interrupt source settings are made in the mailbox interrupt register (MBIMR) and interrupt mask register (IMR). To receive a message, the identifier must be set in advance in the message control (MCx[1] to MCx[8]) for the receiving mailbox. When a message is received, all the bits in the receive message identifier are compared, and if a 100% match is found, the message is stored in the matching mailbox. Mailbox 0 (MB0) has a local acceptance filter mask (LAFM) that allows Don't care settings to be made.

- CPU interrupt source settings

When transmitting, transmission acknowledge and transmission abort acknowledge interrupts can be masked for individual mailboxes in the mailbox interrupt mask register (MBIMR).

When receiving, data frame and remote frame receive wait interrupts can be masked. Interrupt register (IRR) interrupts can be masked in the interrupt mask register (IMR).

- Arbitration field setting

In the arbitration field, the identifier (STD_ID0 to STD_ID10, EXT_ID0 to EXT_ID17) of the message to be received is set. If all the bits in the set identifier do not match, the message is not stored in a mailbox.

Example: Mailbox 1 010_1010_1010 (standard identifier)

Only one kind of message identifier can be received by MB1

Identifier 1: 010_1010_1010

- Local acceptance filter mask (LAFM) setting

The local acceptance filter mask is provided for mailbox 0 (MB0) only, enabling a Don't care specification to be made for all bits in the received identifier. This allows various kinds of messages to be received.

Example: Mailbox 0 010_1010_1010 (standard identifier)

LAFM 000_0000_0011 (0: Care, 1: Don't care)

A total of four kinds of message identifiers can be received by MB0

Identifier 1: 010_1010_1000

Identifier 2: 010_1010_1001

Identifier 3: 010_1010_1010

Identifier 4: 010_1010_1011

Message Reception and Interrupts:

- Message reception CRC check

When a message is received, a CRC check is performed automatically (by hardware). If the result of the CRC check is normal, ACK is transmitted in the ACK field irrespective of whether or not the message can be received.

- Data frame reception

If the received message is confirmed to be error-free by the CRC check, etc., the identifier in the mailbox (and also LAFM in the case of mailbox 0 only) and the identifier of the receive message are compared, and if a complete match is found, the message is stored in the mailbox. The message identifier comparison is carried out on each mailbox in turn, starting with mailbox 0 and ending with mailbox 15. If a complete match is found, the comparison ends at that point, the message is stored in the matching mailbox, and the corresponding receive complete bit (RXPR0 to RXPR15) is set in the receive complete register (RXPR). However, when a mailbox 0 LAFM comparison is carried out, even if the identifier matches, the mailbox comparison sequence does not end at that point, but continues with mailbox 1 and then the remaining mailboxes. It is therefore possible for a message matching mailbox 0 to be received by another mailbox (however, the same message cannot be stored in more than one of mailboxes 1 to 15). If the corresponding bit (MBIMR0 to MBIMR15) in the mailbox interrupt mask register (MBIMR) and the receive message interrupt mask (IMR1) in the interrupt mask register (IMR) are set to the interrupt enable value at this time, an interrupt can be sent to the CPU.

- Remote frame reception

Two kinds of messages—data frames and remote frames—can be stored in mailboxes. A remote frame differs from a data frame in that the remote reception request bit (RTR) in the message control register (MC[x]5) and the data field are 0 bytes. The data length to be returned in a data frame must be stored in the data length code (DLC) in the control field.

When a remote frame (RTR = recessive) is received, the corresponding bit is set in the remote request wait register (RFPR). If the corresponding bit (MBIMR0 to MBIMR15) in the mailbox interrupt mask register (MBIMR) and the remote frame request interrupt mask (IRR2) in the interrupt mask register (IMR) are set to the interrupt enable value at this time, an interrupt can be sent to the CPU.

- Unread message reception

When a received message matches the identifier in a mailbox, the message is stored in the mailbox. If a message overwrite occurs before the CPU reads the message, the corresponding bit (UMSR0 to UMSR15) is set in the unread message register (UMSR). In overwriting of an unread message, when a new message is received before the corresponding bit in the receive complete register (RXPR) has been cleared, the unread message register (UMSR) is set. If the

unread interrupt flag (IRR9) in the interrupt mask register (IMR) is set to the interrupt enable value at this time, an interrupt can be sent to the CPU. Figure 16-10 shows a flowchart of unread message overwriting.

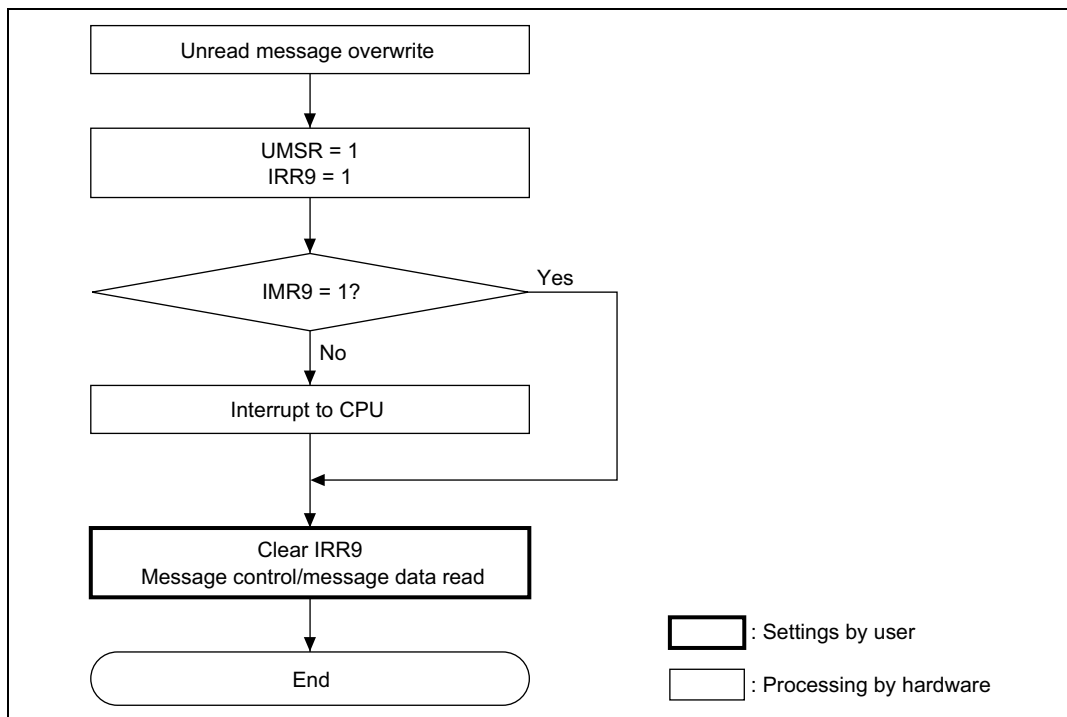

Figure 16-10 Unread Message Overwrite Flowchart

16.3.5 HCAN Sleep Mode

The HCAN is provided with an HCAN sleep mode that places the HCAN module in the sleep state to reduce current dissipation. Figure 16-11 shows a flowchart of the HCAN sleep mode.

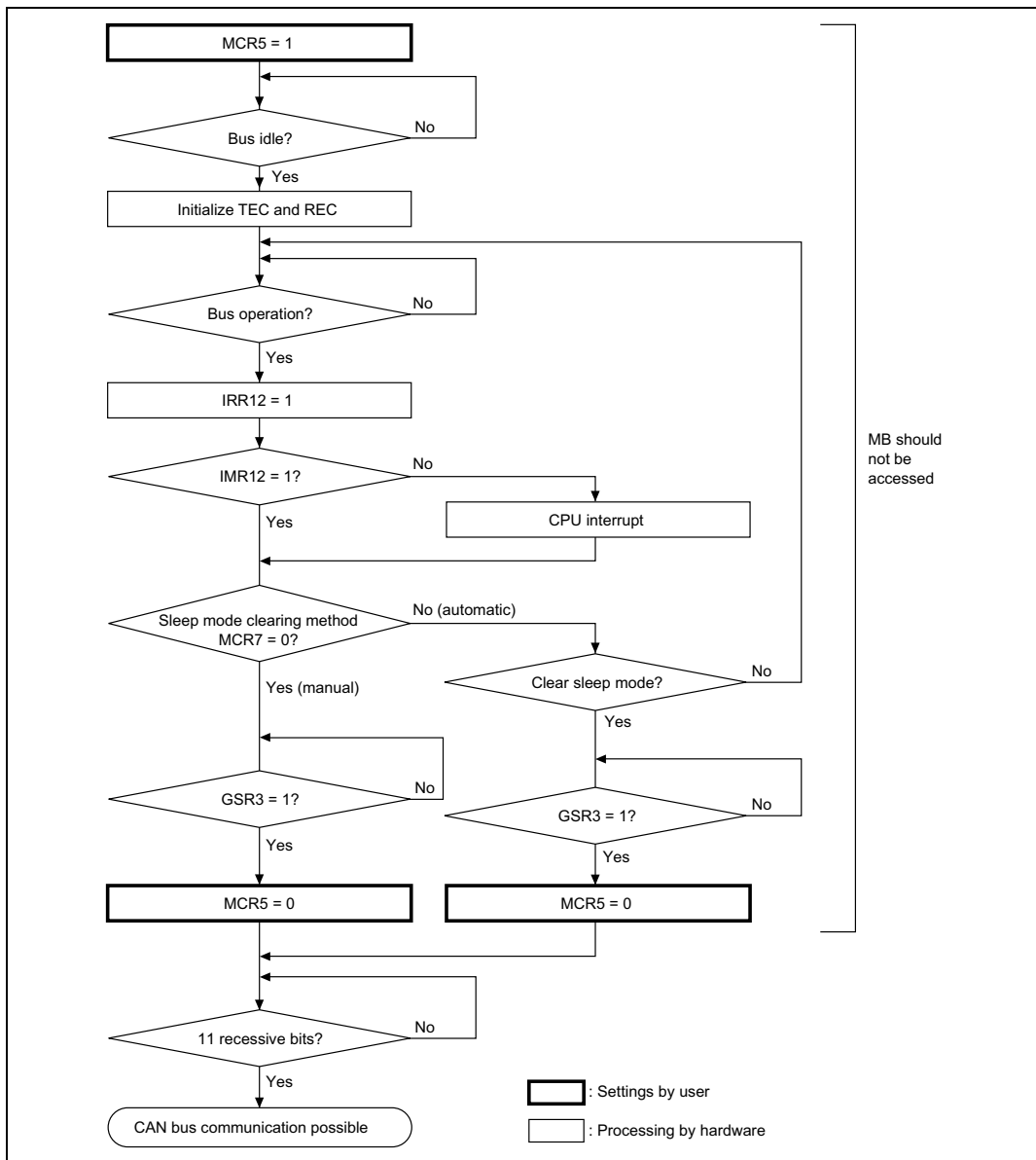

Figure 16-11 HCAN Sleep Mode Flowchart

HCAN sleep mode is entered by setting the HCAN sleep mode bit (MCR5) to 1 in the master control register (MCR). If the CAN bus is operating, the transition to HCAN sleep mode is delayed until the bus becomes idle.

Either of the following methods of clearing HCAN sleep mode can be selected by making a setting in the MCR7 bit.

1. Clearing by software
2. Clearing by CAN bus operation

Eleven recessive bits must be received after HCAN sleep mode is cleared before CAN bus communication is enabled again.

Clearing by software: HCAN sleep mode is cleared by writing a 0 to MCR5 from the CPU.

Clearing by CAN bus operation: Clearing by CAN bus operation occurs automatically when the CAN bus performs an operation and this change is detected. In this case, the first message is not received in the mailbox, and normal reception starts from the next message. When a change is detected on the CAN bus in HCAN sleep mode, the bus operation interrupt flag (IRR12) is set in the interrupt register (IRR). If the bus interrupt mask (IMR12) in the interrupt mask register (IMR) is set to the interrupt enable value at this time, an interrupt can be sent to the CPU.

16.3.6 HCAN Halt Mode

The HCAN halt mode is provided to enable mailbox settings to be changed without performing an HCAN hardware or software reset. Figure 16-12 shows a flowchart of the HCAN halt mode.

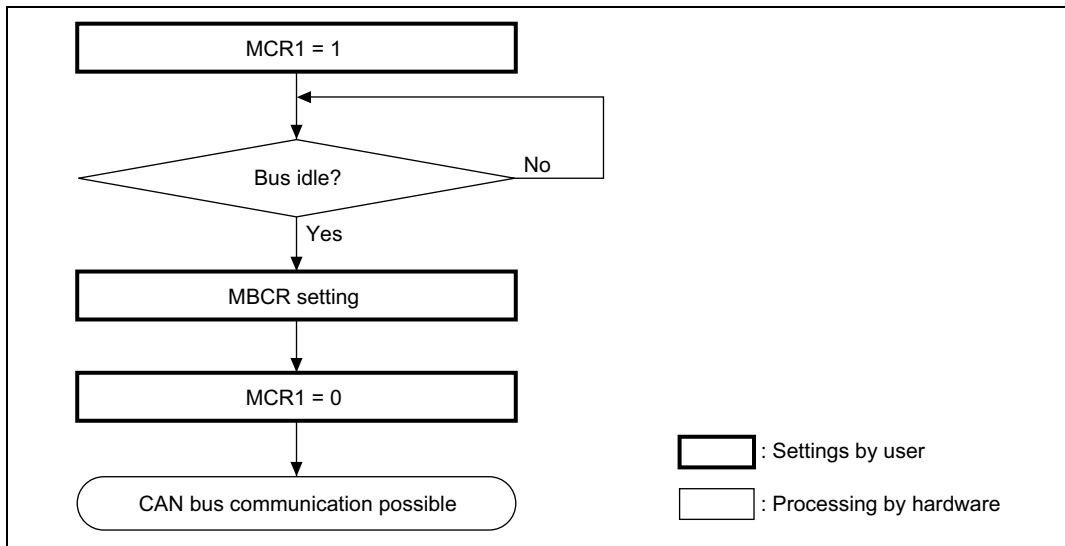

Figure 16-12 HCAN Halt Mode Flowchart

HCAN halt mode is entered by setting the halt request bit (MCR1) to 1 in the master control register (MCR). However, if the CAN bus is operating at the time of a transition, the transition to HCAN ALT mode is delayed until the bus becomes idle.

HCAN halt mode is cleared by clearing MCR1 to 0.

16.3.7 Interrupt Interface

There are 12 HCAN interrupt sources, to which five independent interrupt vectors are assigned. Table 16-5 lists the HCAN interrupt sources.

With the exception of the reset processing vector (IRR0), these sources can be masked. Masking is implemented using the mailbox interrupt mask register (MBIMR) and interrupt mask register (IMR).

Table 16-5 HCAN Interrupt Sources

Channel	IPRM Bits	Vector		IRR Bit	Description
		Vector	Number		
HCAN0	IPRM (2 to 0)	ERS0	108	IRR5	Error passive interrupt (TEC \geq 128 or REC \geq 128)
				IRR6	Bus off interrupt (TEC \geq 256)
		OVR0	108	IRR0	Hardware reset processing interrupt
				IRR2	Remote frame reception interrupt
				IRR3	Error warning interrupt (TEC \geq 96)
				IRR4	Error warning interrupt (REC \geq 96)
				IRR7	Overload frame transmission interrupt
				IRR9	Unread message overwrite interrupt
				IRR12	HCAN sleep mode CAN bus operation interrupt
		RM0	109	IRR1	Mailbox 0 message reception interrupt
		RM1	108	IRR1	Mailbox 1 to 15 message reception interrupt
		SLE0	108	IRR8	Message transmission/cancellation interrupt
		HCAN1	IPRM (6 to 4)	ERS0	106
IRR6	Bus off interrupt (TEC \geq 256)				
OVR0	106			IRR0	Hardware reset processing interrupt
				IRR2	Remote frame reception interrupt
				IRR3	Error warning interrupt (TEC \geq 96)
				IRR4	Error warning interrupt (REC \geq 96)
				IRR7	Overload frame transmission interrupt
				IRR9	Unread message overwrite interrupt
				IRR12	HCAN sleep mode CAN bus operation interrupt
RM0	107			IRR1	Mailbox 0 message reception interrupt
RM1	106			IRR1	Mailbox 1 to 15 message reception interrupt
SLE0	106			IRR8	Message transmission/cancellation interrupt

16.3.8 DTC Interface*

Note: * The DTC is not implemented in the H8S/2635 and H8S/2634.

The DTC can be activated by reception of a message in the HCAN's mailbox 0. When DTC transfer ends after DTC activation has been set, the RXPR0 and RFPR0 flags are acknowledge signal automatically. An interrupt request due to a receive interrupt from the HCAN cannot be sent to the CPU in this case. Figure 16-13 shows a DTC transfer flowchart.

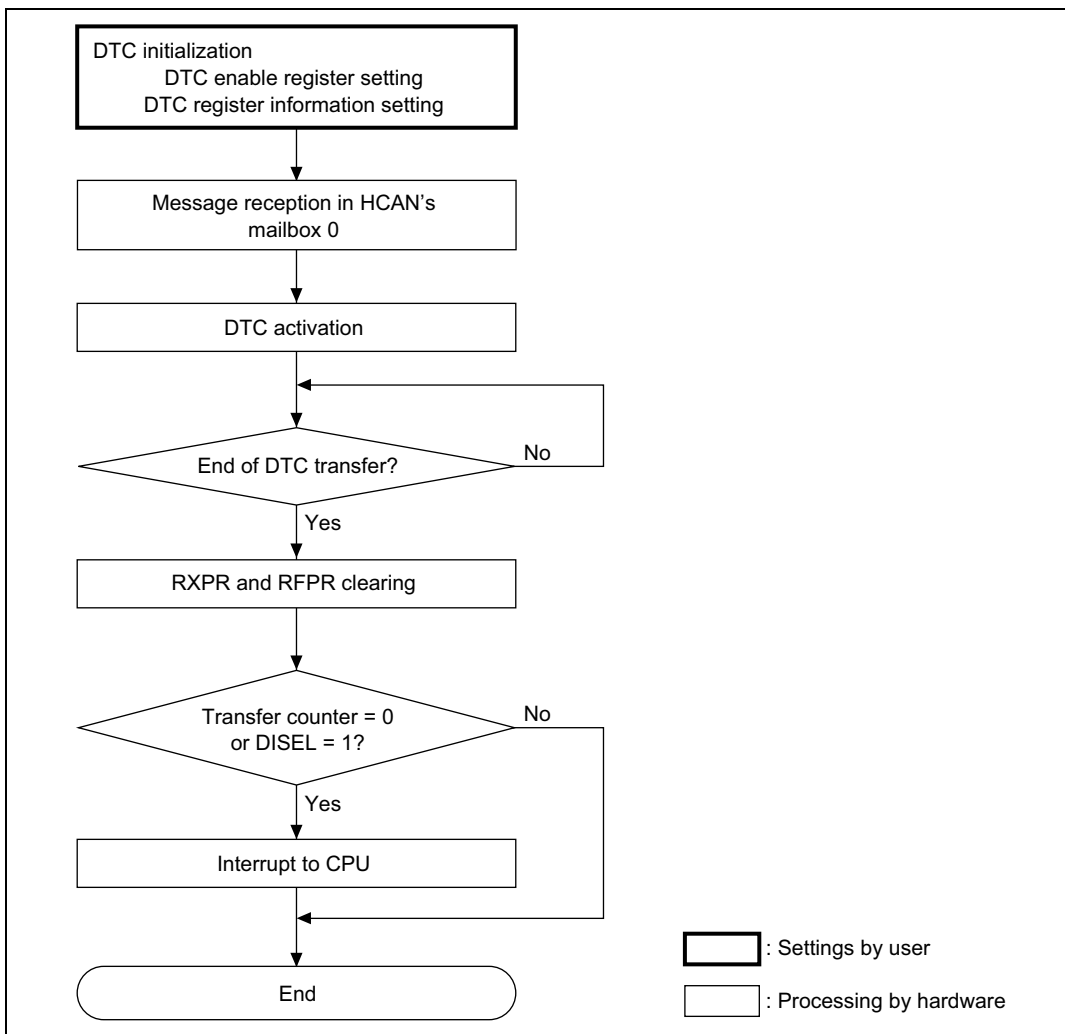

Figure 16-13 DTC Transfer Flowchart

16.4 CAN Bus Interface

A bus transceiver IC is necessary to connect the chip to a CAN bus. A HA13721 transceiver IC, or compatible device, is recommended. Figure 16-14 shows a sample connection diagram.

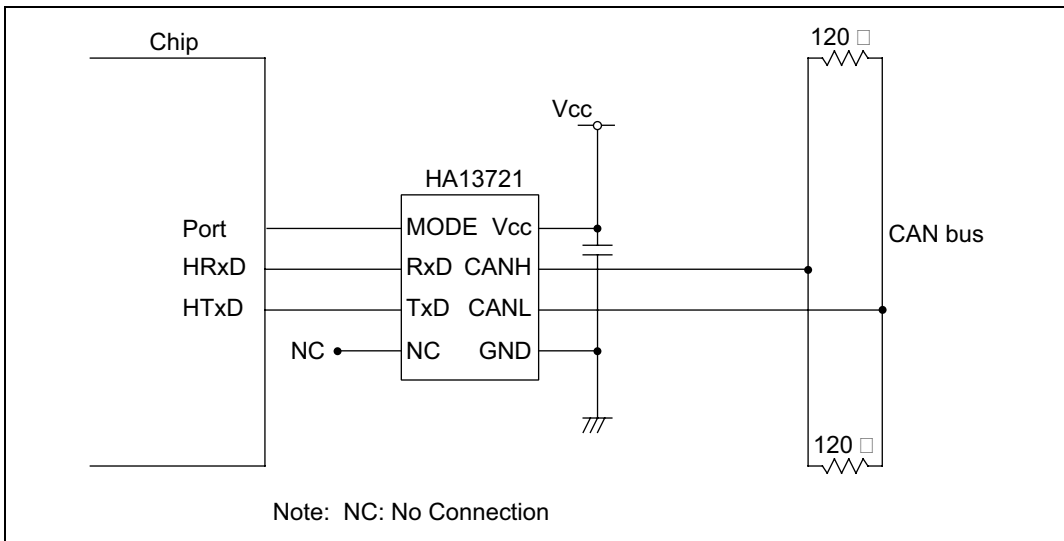

Figure 16-14 High-Speed Interface Using HA13721

16.5 Usage Notes

(1) Reset

The HCAN is reset by a reset, and in hardware standby mode and software standby mode. All the registers are initialized in a reset, but mailboxes (message control (MCx[x])/message data (MDx[x])) are not. However, after powering on, mailboxes (message control (MCx[x])/message data (MDx[x])) are initialized, and their values are undefined. Therefore, mailbox initialization must always be carried out after a reset or a transition to hardware standby mode or software standby mode. Also, the reset interrupt flag (IRR0) is always set after reset input or recovery from software standby mode. As this bit cannot be masked in the interrupt mask register (IMR), if HCAN interrupts are set as enabled by the interrupt controller without this flag having been cleared, an HCAN interrupt will be initiated immediately. IRR0 must therefore be cleared during initialization.

(2) HCAN sleep mode

The bus operation interrupt flag (IRR12) in the interrupt register (IRR) is set by bus operation in HCAN sleep mode. Therefore, this flag is not used by the HCAN to indicate sleep mode release. Also note that the reset status bit (GSR3) in the general status register (GSR) is set in sleep mode.

(3) Interrupts

When the mailbox interrupt mask register (MBIMR) is set, the interrupt register (IRR8,2,1) is not set by reception completion, transmission completion, or transmission cancellation for the set mailboxes.

(4) Error counters

In the case of error active and error passive, REC and TEC normally count up and down. In the bus off state, 11-bit recessive sequences are counted (REC + 1) using REC. If REC reaches 96 during the count, IRR4 and GSR1 are set.

(5) Register access

Byte or word access can be used on all HCAN registers. Longword access cannot be used.

(6) HCAN medium-speed mode

HCAN registers cannot be read or written to in medium-speed mode.

(7) Register retention during standby

All HCAN registers are initialized in hardware standby mode and software standby mode.

(8) Usage of bit manipulation instructions

The HCAN status flags are cleared by writing 1, so do not use a bit manipulation instruction to clear a flag.

When clearing a flag, use the MOV instruction to write 1 to only the bit that is to be cleared.

(9) Operation of TXCR in HCAN

1. When the transmit wait cancel register (TXCR) is used to cancel messages awaiting transmission from a mailbox waiting to transmit, the bits corresponding to TXCR and the transmit wait register (TXPR) are sometimes not cleared in spite of the fact that transmission was cancelled. This situation can arise when all of the following conditions are met.

- The HRxD pin is stuck at 1 because of a CAN bus error, etc.
- One or more mailboxes are waiting to transmit (or transmitting).
- Transmission of a message in a mailbox that is transmitting is cancelled using TXCR.

When this situation occurs the message is not cancelled. However, since TXPR and TXCR continue to incorrectly display the status of the message as in the process of being cancelled, it is not possible to restart transmission even when the HRxD pin is no longer stuck at 1 and the CAN bus is restored to normal status. If there are two or more messages to be transmitted, those messages that are not in the process of being sent are cancelled and the messages in the process of being sent remain in that status.

To avoid the situation described above, either of the following two countermeasures should be implemented.

- Do not use TXCR to cancel transmission of messages. This will ensure that TXPR is cleared and HCAN operates normally after transmission completes normally following recovery by the CAN bus.
 - If it is necessary to cancel transmission of a message, write continuously to bit 1 corresponding to TXCR until the bits corresponding to TXCR become 0. This will ensure that TXPR and TXCR are cleared and that HCAN is restored to normal operation.
2. If TXPR is set, resulting in transmission wait status, when a transition to bus off status takes place, cancellation cannot be performed even if TXCR is set during bus off status because the internal state machine does not operate. After recovery from bus off status, the message is cancelled after one message is either sent or generates a transmission error. The following countermeasure should be taken with regard to clearing messages following recovery from bus off status.

- Clear the messages awaiting transmission by resetting the HCAN module during bus off status. To reset the HCAN module, set and then clear the module stop bits (MSTPC3 and MSTPC2 in MSTPCRC). Note that this will reset all internal values in the HCAN module, so it will be necessary to perform the initial settings once again.

(10) HCAN Transmit Procedure

When transmission is set while the bus is in the idle state, if the next transmission is set or the set transmission is canceled under the following conditions within 50 μ s, the transmit message ID of being set may be damaged.

- When the second transmission has the message whose priority is higher than the first one.
- When the message of the highest priority is canceled in the first transmission.

Make whichever setting shown below to avoid the message IDs from being damaged.

- Set transmission in one TXPR. After transmission of all transmit messages is completed, set transmission again (mass transmission setting). The interval between transmission settings should be 50 μ s or longer.
- Make the transmission setting according to the priority of transmit messages.
- Set the interval to be 50 μ s or longer between TXPR and another TXPR or between TXPR and TXCR.

Table 16-6 Interval Limitation between TXPR and TXPR or between TXPR and TXCR

Baud Rate (bps)	Set Interval (μ s)
1 M	50
500 k	50
250 k	50

(11) Canceling HCAN Reset and HCAN Sleep

Before canceling the software reset or sleep mode for HCAN (MCR0 = 0 or MCR5 = 0), confirm that the reset status bit (GSR3) is set to 1.

(12) Accessing Mailbox in HCAN Sleep Mode

The mailboxes should not be accessed in HCAN sleep mode. If mailboxes are accessed in HCAN sleep mode, the CPU may stop. When registers are accessed in HCAN sleep mode, the CPU does not stop. When mailboxes are accessed in modes other than sleep mode, the CPU does not stop.

Section 17 A/D Converter

Note: The H8S/2635 Group is not equipped with a DTC.

17.1 Overview

The chip incorporates a successive approximation type 10-bit A/D converter that allows up to twelve analog input channels to be selected.

17.1.1 Features

A/D converter features are listed below.

- 10-bit resolution
- Twelve input channels
- Settable analog conversion voltage range
 - Conversion of analog voltages with the reference voltage pin (V_{ref}) as the analog reference voltage
- High-speed conversion
 - Minimum conversion time: 13.3 μ s per channel (at 20 MHz operation)
- Choice of single mode or scan mode
 - Single mode: Single-channel A/D conversion
 - Scan mode: Continuous A/D conversion on 1 to 4 channels
- Four data registers
 - Conversion results are held in a 16-bit data register for each channel
- Sample and hold function
- Three kinds of conversion start
 - Choice of software or timer conversion start trigger (TPU), or \overline{ADTRG} pin
- A/D conversion end interrupt generation
 - A/D conversion end interrupt (ADI) request can be generated at the end of A/D conversion
- Module stop mode can be set
 - As the initial setting, A/D converter operation is halted. Register access is enabled by exiting module stop mode.

17.1.2 Block Diagram

Figure 17-1 shows a block diagram of the A/D converter.

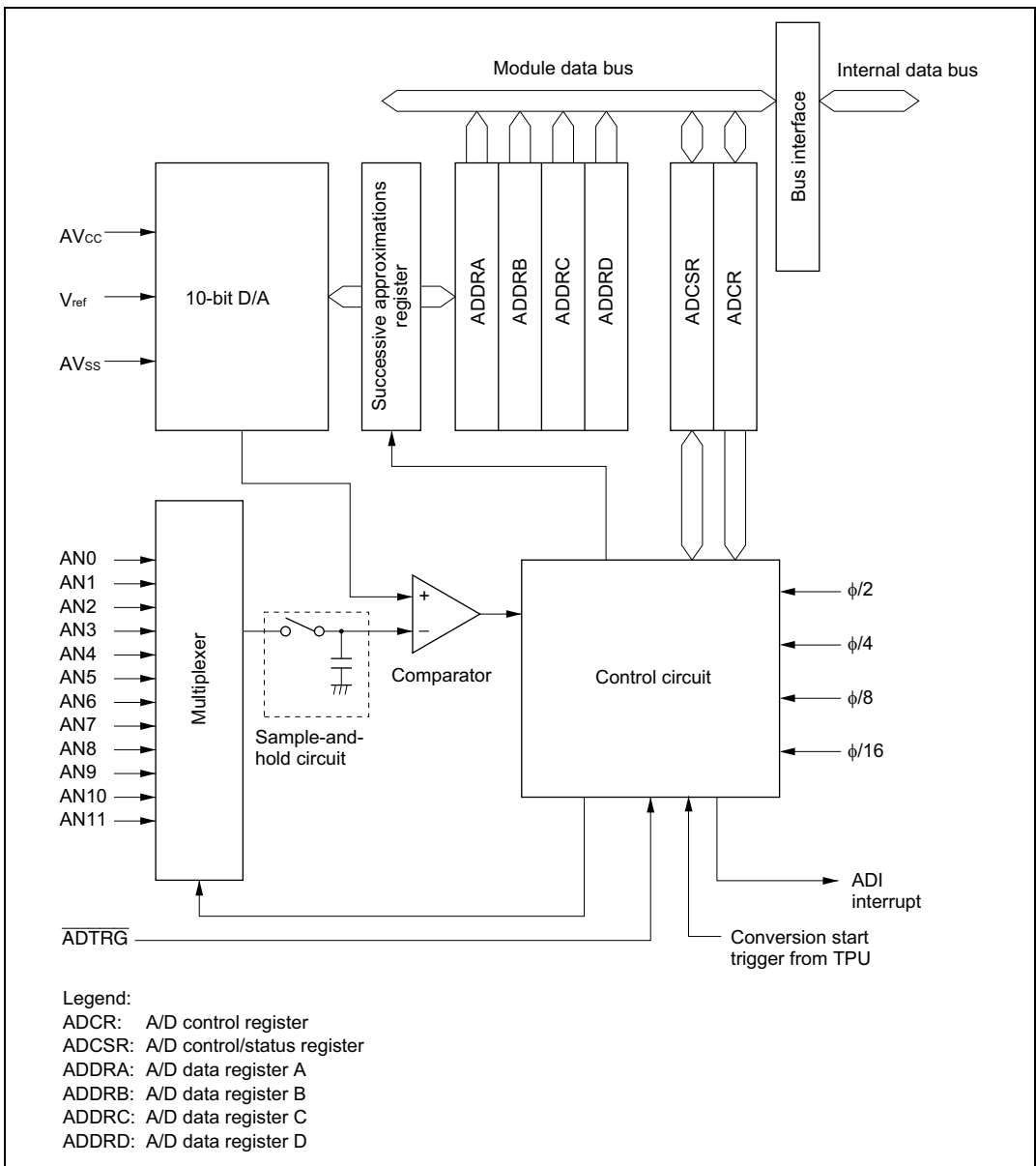

Figure 17-1 Block Diagram of A/D Converter

17.1.3 Pin Configuration

Table 17-1 summarizes the input pins used by the A/D converter.

The AVCC and AVSS pins are the power supply pins for the analog block in the A/D converter. The Vref pin is the A/D conversion reference voltage pin.

The 12 analog input pins are divided into two channel sets and two groups, with analog input pins 0 to 7 (AN0 to AN7) comprising channel set 0, analog input pins 8 to 11 (AN8 to AN11) comprising channel set 1, analog input pins 0 to 3 and 8 to 11 (AN0 to AN3, AN8 to AN11) comprising group 0, and analog input pins 4 to 7 (AN4 to AN7) comprising group 1.

Table 17-1 A/D Converter Pins

Pin Name	Symbol	I/O	Function
Analog power supply pin	AVCC	Input	Analog block power supply
Analog ground pin	AVSS	Input	Analog block ground and reference voltage
Reference voltage pin	Vref	Input	A/D conversion reference voltage
Analog input pin 0	AN0	Input	Channel set 0 (CH3 = 0) group 0 analog inputs
Analog input pin 1	AN1	Input	
Analog input pin 2	AN2	Input	
Analog input pin 3	AN3	Input	
Analog input pin 4	AN4	Input	Channel set 0 (CH3 = 0) group 1 analog inputs
Analog input pin 5	AN5	Input	
Analog input pin 6	AN6	Input	
Analog input pin 7	AN7	Input	
Analog input pin 8	AN8	Input	Channel set 1 (CH3 = 1) group 0 analog inputs
Analog input pin 9	AN9	Input	
Analog input pin 10	AN10	Input	
Analog input pin 11	AN11	Input	
A/D external trigger input pin	$\overline{\text{ADTRG}}$	Input	External trigger input for starting A/D conversion

17.1.4 Register Configuration

Table 17-2 summarizes the registers of the A/D converter.

Table 17-2 A/D Converter Registers

Name	Abbreviation	R/W	Initial Value	Address^{*1}
A/D data register AH	ADDRAH	R	H'00	H'FF90
A/D data register AL	ADDRAL	R	H'00	H'FF91
A/D data register BH	ADDRBH	R	H'00	H'FF92
A/D data register BL	ADDRBL	R	H'00	H'FF93
A/D data register CH	ADDRCH	R	H'00	H'FF94
A/D data register CL	ADDRCL	R	H'00	H'FF95
A/D data register DH	ADDRDH	R	H'00	H'FF96
A/D data register DL	ADDRDL	R	H'00	H'FF97
A/D control/status register	ADCSR	R/(W) ^{*2}	H'00	H'FF98
A/D control register	ADCR	R/W	H'33	H'FF99
Module stop control register A	MSTPCRA	R/W	H'3F	H'FDE8

Notes: 1. Lower 16 bits of the address.

2. Bit 7 can only be written with 0 for flag clearing.

17.2 Register Descriptions

17.2.1 A/D Data Registers A to D (ADDRA to ADDR D)

Bit	:	15	14	13	12	11	10	9	8	7	6	5	4	3	2	1	0
		AD9	AD8	AD7	AD6	AD5	AD4	AD3	AD2	AD1	AD0	—	—	—	—	—	—
Initial value	:	0	0	0	0	0	0	0	0	0	0	0	0	0	0	0	0
R/W	:	R	R	R	R	R	R	R	R	R	R	R	R	R	R	R	R

There are four 16-bit read-only ADDR registers, ADDRA to ADDR D, used to store the results of A/D conversion.

The 10-bit data resulting from A/D conversion is transferred to the ADDR register for the selected channel and stored there. The upper 8 bits of the converted data are transferred to the upper byte (bits 15 to 8) of ADDR, and the lower 2 bits are transferred to the lower byte (bits 7 and 6) and stored. Bits 5 to 0 are always read as 0.

The correspondence between the analog input channels and ADDR registers is shown in table 17-3.

ADDR can always be read by the CPU. The upper byte can be read directly, but for the lower byte, data transfer is performed via a temporary register (TEMP). For details, see section 17.3, Interface to Bus Master.

The ADDR registers are initialized to H'0000 by a reset, and in standby mode or module stop mode.

Table 17-3 Analog Input Channels and Corresponding ADDR Registers

Analog Input Channel				
Channel Set 0 (CH3 = 0)		Channel Set 1 (CH3 = 1)		A/D Data Register
Group 0	Group 1	Group 0	Group 1	
AN0	AN4	AN8	Setting prohibited	ADDRA
AN1	AN5	AN9	Setting prohibited	ADDRB
AN2	AN6	AN10	Setting prohibited	ADDRC
AN3	AN7	AN11	Setting prohibited	ADDRD

17.2.2 A/D Control/Status Register (ADCSR)

Bit	:	7	6	5	4	3	2	1	0
		ADF	ADIE	ADST	SCAN	CH3	CH2	CH1	CH0
Initial value	:	0	0	0	0	0	0	0	0
R/W	:	R/(W)*	R/W	R/W	R/W	R/W	R/W	R/W	R/W

Note: * Only 0 can be written to bit 7, to clear this flag.

ADCSR is an 8-bit readable/writable register that controls A/D conversion operations.

ADCSR is initialized to H'00 by a reset, and in hardware standby mode or module stop mode.

Bit 7—A/D End Flag (ADF): Status flag that indicates the end of A/D conversion.

Bit 7

ADF	Description
0	[Clearing conditions] (Initial value) <ul style="list-style-type: none"> When 0 is written to the ADF flag after reading ADF = 1 When the DTC is activated by an ADI interrupt and ADDR is read
1	[Setting conditions] <ul style="list-style-type: none"> Single mode: When A/D conversion ends Scan mode: When A/D conversion ends on all specified channels

Bit 6—A/D Interrupt Enable (ADIE): Selects enabling or disabling of interrupt (ADI) requests at the end of A/D conversion.

Bit 6

ADIE	Description
0	A/D conversion end interrupt (ADI) request disabled (Initial value)
1	A/D conversion end interrupt (ADI) request enabled

Bit 5—A/D Start (ADST): Selects starting or stopping on A/D conversion. Holds a value of 1 during A/D conversion.

The ADST bit can be set to 1 by software, a timer conversion start trigger, or the A/D external trigger input pin ($\overline{\text{ADTRG}}$).

Bit 5

ADST	Description
0	A/D conversion stopped (Initial value)
1	Single mode: A/D conversion is started. Cleared to 0 automatically when conversion on the specified channel ends Scan mode: A/D conversion is started. Conversion continues sequentially on the selected channels until ADST is cleared to 0 by software, a reset, or a transition to standby mode or module stop mode.

Bit 4—Scan Mode (SCAN): Selects single mode or scan mode as the A/D conversion operating mode. See section 17.4, Operation, for single mode and scan mode operation. Only set the SCAN bit while conversion is stopped (ADST = 0).

Bit 4

SCAN	Description
0	Single mode (Initial value)
1	Scan mode

Bit 3—Channel Select 3 (CH3): Switches the analog input pins assigned to group 0 or group 1. Setting CH3 to 1 enables AN8 to AN11 to be used instead of AN0 to AN7.

Bit 3

CH3	Description
1	AN8 to AN11 are group 0 analog input pins
0	AN0 to AN3 are group 0 analog input pins, AN4 to AN7 are group 1 analog input pins (Initial value)

Bits 2 to 0—Channel Select 2 to 0 (CH2 to CH0): Together with the SCAN bit, these bits select the analog input channels.

Only set the input channel while conversion is stopped (ADST = 0).

Channel Selection				Description		
CH3	CH2	CH1	CH0	Single Mode (SCAN = 0)	Scan Mode (SCAN = 1)	
0	0	0	0	AN0 (Initial value)	AN0	
			1	AN1	AN0, AN1	
		1	0	AN2	AN0 to AN2	
			1	AN3	AN0 to AN3	
	1	0	0	AN4	AN4	
			1	AN5	AN4, AN5	
		1	0	AN6	AN4 to AN6	
1	0	0	0	AN8	AN8	
			1	AN9	AN8, AN9	
			1	AN10	AN8 to AN10	
		1	0	AN11	AN8 to AN11	
			0	0	Setting prohibited	Setting prohibited
				1	Setting prohibited	Setting prohibited
	1	1	0	0	Setting prohibited	Setting prohibited
				1	Setting prohibited	Setting prohibited
			1	0	Setting prohibited	Setting prohibited
				1	Setting prohibited	Setting prohibited

17.2.3 A/D Control Register (ADCR)

Bit	:	7	6	5	4	3	2	1	0
		TRGS1	TRGS0	—	—	CKS1	CKS0	—	—
Initial value	:	0	0	1	1	0	0	1	1
R/W	:	R/W	R/W	—	—	R/W	R/W	—	—

ADCR is an 8-bit readable/writable register that enables or disables external triggering of A/D conversion operations and sets the A/D conversion time.

ADCR is initialized to H'33 by a reset, and in standby mode or module stop mode.

Bits 7 and 6—Timer Trigger Select 1 and 0 (TRGS1, TRGS0): Select enabling or disabling of the start of A/D conversion by a trigger signal. Only set bits TRGS1 and TRGS0 while conversion is stopped (ADST = 0).

Bit 7	Bit 6	Description
TRGS1	TRGS0	Description
0	0	A/D conversion start by software is enabled (Initial value)
	1	A/D conversion start by TPU conversion start trigger is enabled
1	0	Setting prohibited
	1	A/D conversion start by external trigger pin (\overline{ADTRG}) is enabled

Bits 5, 4, 1, and 0—Reserved: These bits are reserved; they are always read as 1 and cannot be modified.

Bits 3 and 2—Clock Select 1 and 0 (CKS1, CKS0): These bits select the A/D conversion time. The conversion time should be changed only when ADST = 0.

Set bits CKS1 and CKS0 to give a conversion time of at least 10 μ s.

Bit 3	Bit 2	Description
CKS1	CKS0	Description
0	0	Conversion time = 530 states (max.) (Initial value)
	1	Conversion time = 266 states (max.)
1	0	Conversion time = 134 states (max.)
	1	Conversion time = 68 states (max.)

17.2.4 Module Stop Control Register A (MSTPCRA)

Bit	:	7	6	5	4	3	2	1	0
		MSTPA7	MSTPA6	MSTPA5	MSTPA4	MSTPA3	MSTPA2	MSTPA1	MSTPA0
Initial value	:	0	0	1	1	1	1	1	1
R/W	:	R/W	R/W	R/W	R/W	R/W	R/W	R/W	R/W

MSTPCR is an 8-bit readable/writable register that performs module stop mode control.

When the MSTPA1 bit in MSTPCR is set to 1, A/D converter operation stops at the end of the bus cycle and a transition is made to module stop mode. Registers cannot be read or written to in module stop mode. For details, see section 23A.5, 23B.5, Module Stop Mode.

MSTPCRA is initialized to H'3F by a reset and in hardware standby mode. It is not initialized by a reset and in software standby mode.

Bit 1—Module Stop (MSTPA1): Specifies the A/D converter module stop mode.

Bit 1

MSTPA1	Description
0	A/D converter module stop mode cleared
1	A/D converter module stop mode set (Initial value)

17.3 Interface to Bus Master

ADDRA to ADDR_D are 16-bit registers, and the data bus to the bus master is 8 bits wide. Therefore, in accesses by the bus master, the upper byte is accessed directly, but the lower byte is accessed via a temporary register (TEMP).

A data read from ADDR is performed as follows. When the upper byte is read, the upper byte value is transferred to the CPU and the lower byte value is transferred to TEMP. Next, when the lower byte is read, the TEMP contents are transferred to the CPU.

When reading ADDR, always read the upper byte before the lower byte. It is possible to read only the upper byte, but if only the lower byte is read, incorrect data may be obtained.

Figure 17-2 shows the data flow for ADDR access.

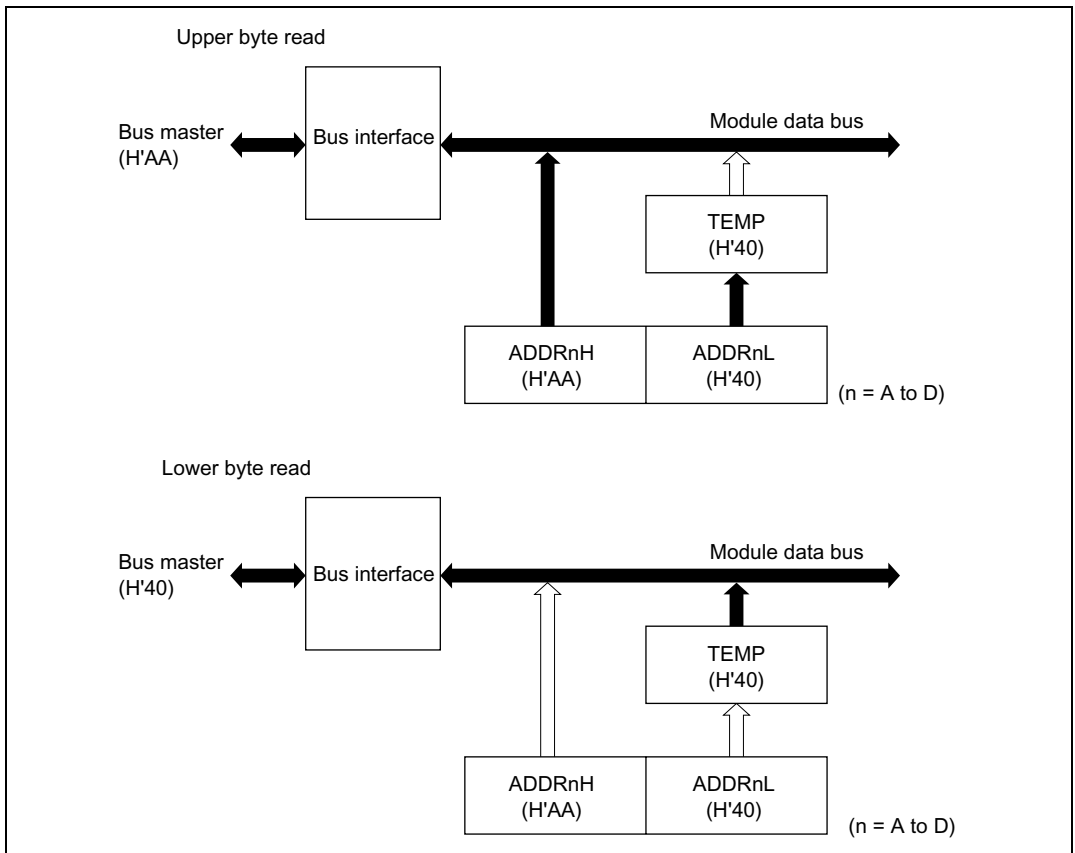

Figure 17-2 ADDR Access Operation (Reading H'AA40)

17.4 Operation

The A/D converter operates by successive approximation with 10-bit resolution. It has two operating modes: single mode and scan mode.

17.4.1 Single Mode (SCAN = 0)

Single mode is selected when A/D conversion is to be performed on a single channel only. A/D conversion is started when the ADST bit is set to 1, according to the software or external trigger input. The ADST bit remains set to 1 during A/D conversion, and is automatically cleared to 0 when conversion ends.

On completion of conversion, the ADF flag is set to 1. If the ADIE bit is set to 1 at this time, an ADI interrupt request is generated. The ADF flag is cleared by writing 0 after reading ADCSR.

When the operating mode or analog input channel must be changed during analog conversion, to prevent incorrect operation, first clear the ADST bit to 0 in ADCSR to halt A/D conversion. After making the necessary changes, set the ADST bit to 1 to start A/D conversion again. The ADST bit can be set at the same time as the operating mode or input channel is changed.

Typical operations when channel 1 (AN1) is selected in single mode are described next. Figure 17-3 shows a timing diagram for this example.

- [1] Single mode is selected (SCAN = 0), input channel AN1 is selected (CH3 = 0, CH2 = 0, CH1 = 0, CH0 = 1), the A/D interrupt is enabled (ADIE = 1), and A/D conversion is started (ADST = 1).
- [2] When A/D conversion is completed, the result is transferred to ADDR0. At the same time the ADF flag is set to 1, the ADST bit is cleared to 0, and the A/D converter becomes idle.
- [3] Since ADF = 1 and ADIE = 1, an ADI interrupt is requested.
- [4] The A/D interrupt handling routine starts.
- [5] The routine reads ADCSR, then writes 0 to the ADF flag.
- [6] The routine reads and processes the connection result (ADDR0).
- [7] Execution of the A/D interrupt handling routine ends. After that, if the ADST bit is set to 1, A/D conversion starts again and steps [2] to [7] are repeated.

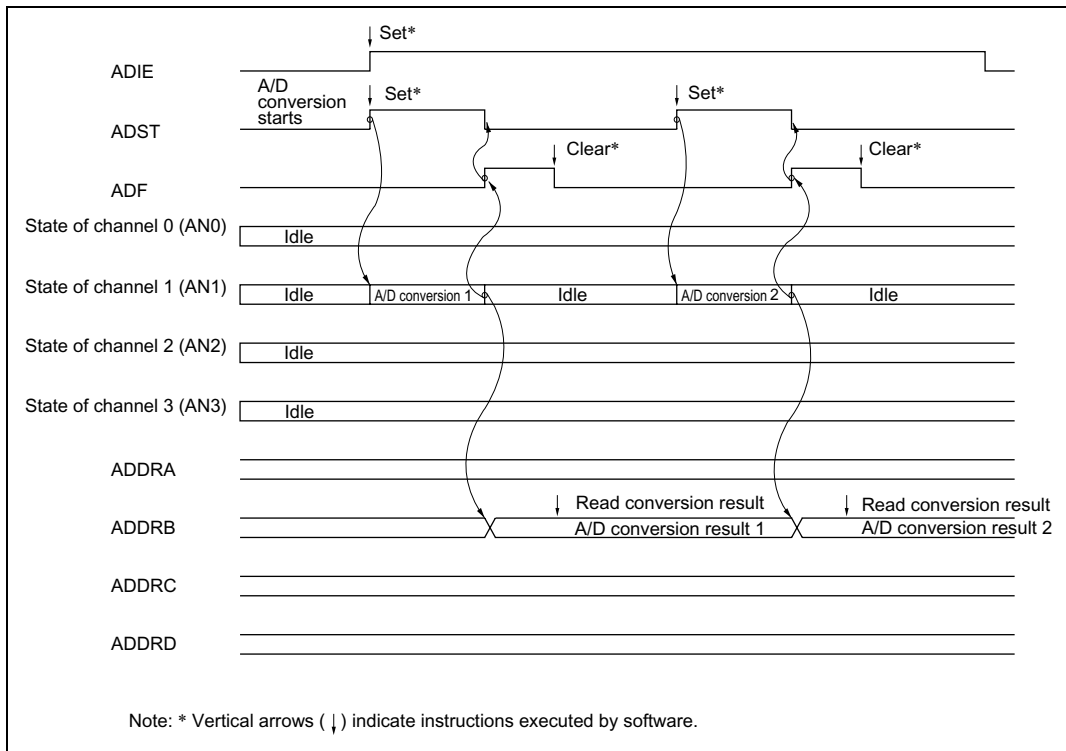

Figure 17-3 Example of A/D Converter Operation (Single Mode, Channel 1 Selected)

17.4.2 Scan Mode (SCAN = 1)

Scan mode is useful for monitoring analog inputs in a group of one or more channels. When the ADST bit is set to 1 by a software, timer or external trigger input, A/D conversion starts on the first channel in the group (AN0). When two or more channels are selected, after conversion of the first channel ends, conversion of the second channel (AN1) starts immediately. A/D conversion continues cyclically on the selected channels until the ADST bit is cleared to 0. The conversion results are transferred for storage into the ADDR registers corresponding to the channels.

When the operating mode or analog input channel must be changed during analog conversion, to prevent incorrect operation, first clear the ADST bit to 0 in ADCSR to halt A/D conversion. After making the necessary changes, set the ADST bit to 1 to start A/D conversion again from the first channel (AN0). The ADST bit can be set at the same time as the operating mode or input channel is changed.

Typical operations when three channels (AN0 to AN2) are selected in scan mode are described next. Figure 17-4 shows a timing diagram for this example.

- [1] Scan mode is selected (SCAN = 1), channel set 0 is selected (CH3 = 0), scan group 0 is selected (CH2 = 0), analog input channels AN0 to AN2 are selected (CH1 = 1, CH0 = 0), and A/D conversion is started (ADST = 1)
- [2] When A/D conversion of the first channel (AN0) is completed, the result is transferred to ADDRA. Next, conversion of the second channel (AN1) starts automatically.
- [3] Conversion proceeds in the same way through the third channel (AN2).
- [4] When conversion of all the selected channels (AN0 to AN2) is completed, the ADF flag is set to 1 and conversion of the first channel (AN0) starts again. If the ADIE bit is set to 1 at this time, an ADI interrupt is requested after A/D conversion ends.
- [5] Steps [2] to [4] are repeated as long as the ADST bit remains set to 1. When the ADST bit is cleared to 0, A/D conversion stops. After that, if the ADST bit is set to 1, A/D conversion starts again from the first channel (AN0).

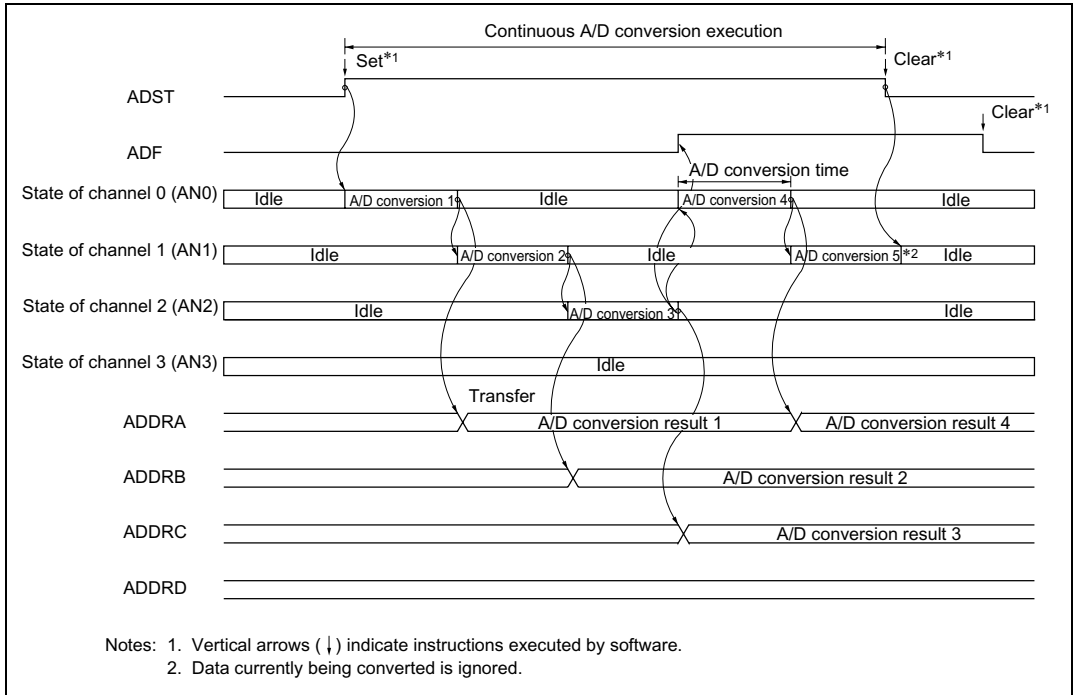

**Figure 17-4 Example of A/D Converter Operation
(Scan Mode, 3 Channels AN0 to AN2 Selected)**

17.4.3 Input Sampling and A/D Conversion Time

The A/D converter has an on-chip sample-and-hold circuit. The A/D converter samples the analog input at a time t_D after the ADST bit is set to 1, then starts conversion. Figure 17-5 shows the A/D conversion timing. Table 17-4 indicates the A/D conversion time.

As indicated in figure 17-5, the A/D conversion time includes t_D and the input sampling time. The length of t_D varies depending on the timing of the write access to ADCSR. The total conversion time therefore varies within the ranges indicated in table 17-4.

In scan mode, the values given in table 17-4 apply to the first conversion time. The values given in table 17-5 apply to the second and subsequent conversions. In both cases, set bits CKS1 and CKS0 in ADCR to give a conversion time of at least 10 μ s.

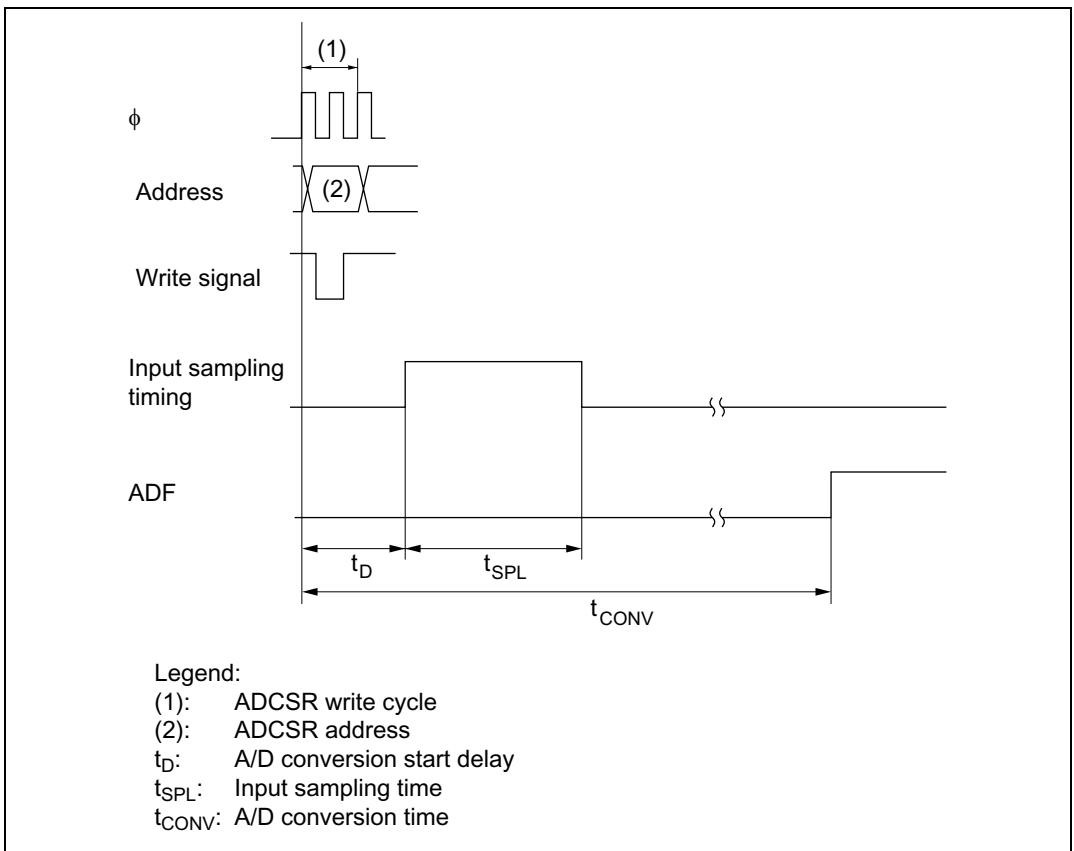

Figure 17-5 A/D Conversion Timing

Table 17-4 A/D Conversion Time (Single Mode)

Item	Symbol	CKS1 = 0						CKS1 = 0					
		CKS0 = 0			CKS0 = 1			CKS0 = 0			CKS0 = 1		
		Min	Typ	Max	Min	Typ	Max	Min	Typ	Max	Min	Typ	Max
A/D conversion start delay t_D		18	—	33	10	—	17	6	—	9	4	—	5
Input sampling time	t_{SPL}	—	127	—	—	63	—	—	31	—	—	15	—
A/D conversion time	t_{CONV}	515	—	530	259	—	266	131	—	134	67	—	68

Note: Values in the table are the number of states.

Table 17-5 A/D Conversion Time (Scan Mode)

CKS1	CKS0	Conversion Time (State)
0	0	512 (Fixed)
	1	256 (Fixed)
1	0	128 (Fixed)
	1	64 (Fixed)

17.4.4 External Trigger Input Timing

A/D conversion can be externally triggered. When the TRGS1 and TRGS0 bits are set to 11 in ADCR, external trigger input is enabled at the \overline{ADTRG} pin. A falling edge at the \overline{ADTRG} pin sets the ADST bit to 1 in ADCSR, starting A/D conversion. Other operations, in both single and scan modes, are the same as if the ADST bit has been set to 1 by software. Figure 17-6 shows the timing.

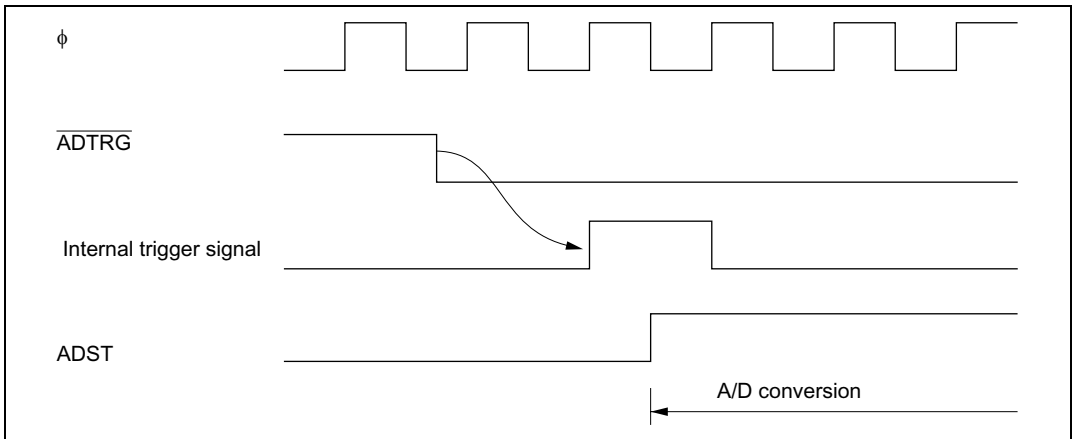

Figure 17-6 External Trigger Input Timing

17.5 Interrupts

The A/D converter generates an A/D conversion end interrupt (ADI) at the end of A/D conversion. ADI interrupt requests can be enabled or disabled by means of the ADIE bit in ADCSR.

The DTC can be activated by an ADI interrupt. Having the converted data read by the DTC in response to an ADI interrupt enables continuous conversion to be achieved without imposing a load on software.

The A/D converter interrupt source is shown in table 17-6.

Table 17-6 A/D Converter Interrupt Source

Interrupt Source	Description	DTC Activation
ADI	Interrupt due to end of conversion	Possible

17.6 Usage Notes

The following points should be noted when using the A/D converter.

Setting Range of Analog Power Supply and Other Pins:

(1) Analog input voltage range

The voltage applied to analog input pin ANn during A/D conversion should be in the range $AVSS \leq ANn \leq Vref$.

(2) Relation between AVCC, AVSS and VCC, VSS

As the relationship between AVSS and VSS, set $AVSS = VSS$. If the A/D converter is not used, set $AVCC = VCC$, and do not leave the AVCC and AVSS pins open or no account.

(3) Vref input range

The analog reference voltage input at the Vref pin set in the range $Vref \leq AVCC$.

If conditions (1), (2), and (3) above are not met, the reliability of the device may be adversely affected.

Notes on Board Design: In board design, digital circuitry and analog circuitry should be as mutually isolated as possible, and layout in which digital circuit signal lines and analog circuit signal lines cross or are in close proximity should be avoided as far as possible. Failure to do so may result in incorrect operation of the analog circuitry due to inductance, adversely affecting A/D conversion values.

Also, digital circuitry must be isolated from the analog input signals (AN0 to AN11), analog reference power supply (Vref), and analog power supply (AVCC) by the analog ground (AVSS). Also, the analog ground (AVSS) should be connected at one point to a stable digital ground (VSS) on the board.

Notes on Noise Countermeasures: A protection circuit connected to prevent damage due to an abnormal voltage such as an excessive surge at the analog input pins (AN0 to AN11) and analog reference power supply (Vref) should be connected between AVCC and AVSS as shown in figure 17-7.

Also, the bypass capacitors connected to AVCC and Vref and the filter capacitor connected to AN0 to AN11 must be connected to AVSS.

If a filter capacitor is connected as shown in figure 17-7, the input currents at the analog input pins (AN0 to AN11) are averaged, and so an error may arise. Also, when A/D conversion is performed frequently, as in scan mode, if the current charged and discharged by the capacitance of the

sample-and-hold circuit in the A/D converter exceeds the current input via the input impedance (R_{in}), an error will arise in the analog input pin voltage. Careful consideration is therefore required when deciding the circuit constants.

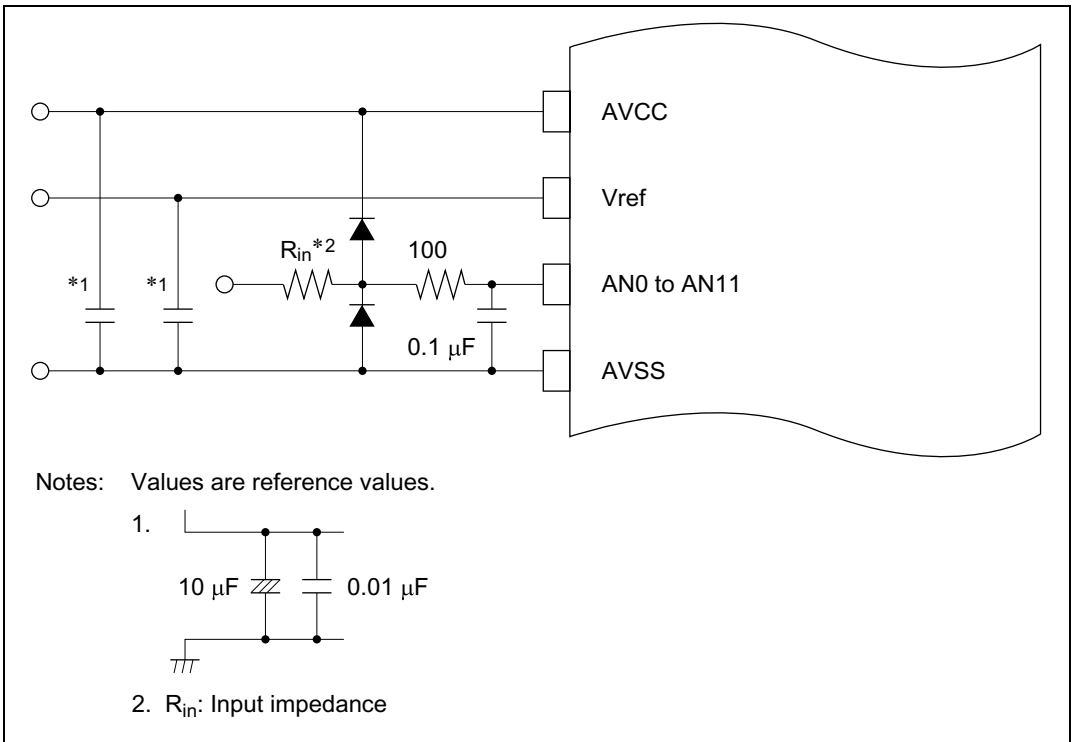
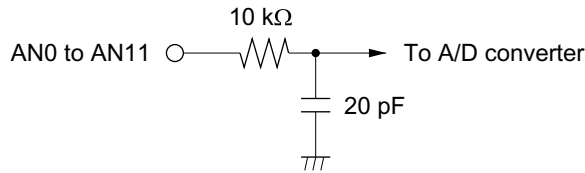

Figure 17-7 Example of Analog Input Protection Circuit

Table 17-7 Analog Pin Specifications

Item	Min	Max	Unit
Analog input capacitance	—	20	pF
Permissible signal source impedance	—	5	k Ω



Note: Values are reference values.

Figure 17-8 Analog Input Pin Equivalent Circuit

A/D Conversion Precision Definitions: The chip's A/D conversion precision definitions are given below.

- Resolution
The number of A/D converter digital output codes
- Offset error
The deviation of the analog input voltage value from the ideal A/D conversion characteristic when the digital output changes from the minimum voltage value B'000000000 (H'00) to B'000000001 (H'01) (see figure 17-10).
- Full-scale error
The deviation of the analog input voltage value from the ideal A/D conversion characteristic when the digital output changes from B'111111110 (H'3E) to B'111111111 (H'3F) (see figure 17-10).
- Quantization error
The deviation inherent in the A/D converter, given by 1/2 LSB (see figure 17-9).
- Nonlinearity error
The error with respect to the ideal A/D conversion characteristic between the zero voltage and the full-scale voltage. Does not include the offset error, full-scale error, or quantization error.
- Absolute precision
The deviation between the digital value and the analog input value. Includes the offset error, full-scale error, quantization error, and nonlinearity error.

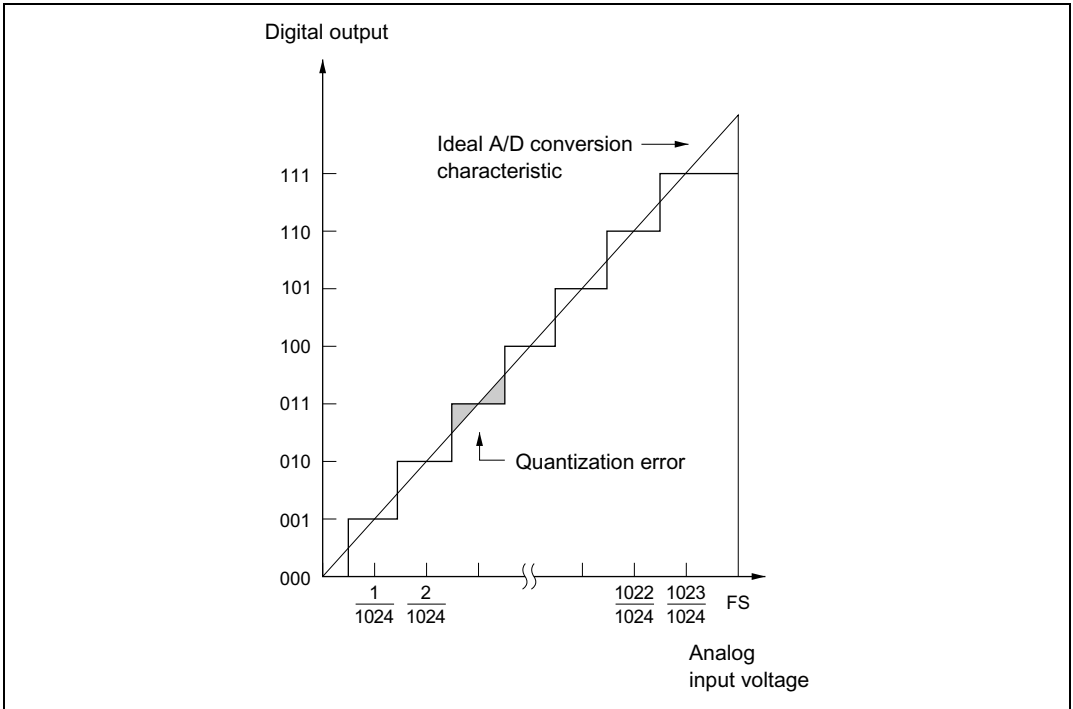

Figure 17-9 A/D Conversion Precision Definitions (1)

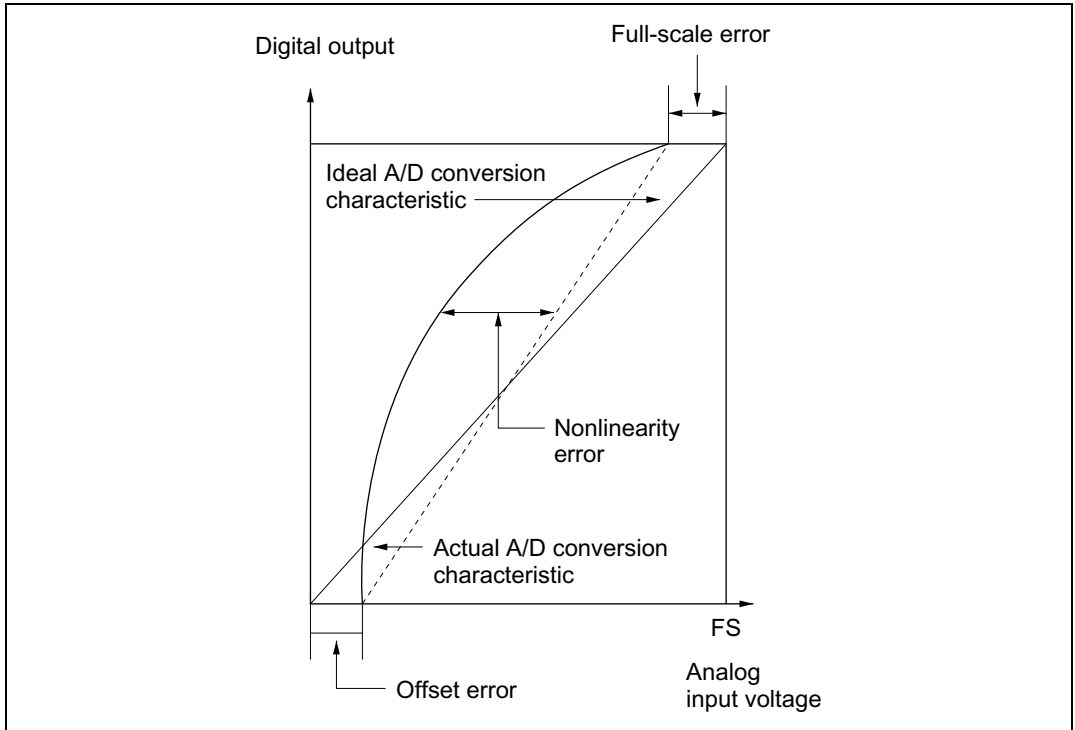

Figure 17-10 A/D Conversion Precision Definitions (2)

Permissible Signal Source Impedance: The chip's analog input is designed so that conversion precision is guaranteed for an input signal for which the signal source impedance is 10 k Ω or less. This specification is provided to enable the A/D converter's sample-and-hold circuit input capacitance to be charged within the sampling time; if the sensor output impedance exceeds 10 k Ω , charging may be insufficient and it may not be possible to guarantee the A/D conversion precision.

However, if a large capacitance is provided externally, the input load will essentially comprise only the internal input resistance of 10 k Ω , and the signal source impedance is ignored.

However, since a low-pass filter effect is obtained in this case, it may not be possible to follow an analog signal with a large differential coefficient (e.g., 5 mV/ μ s or greater).

When converting a high-speed analog signal, a low-impedance buffer should be inserted.

Influences on Absolute Precision: Adding capacitance results in coupling with GND, and therefore noise in GND may adversely affect absolute precision. Be sure to make the connection to an electrically stable GND such as AVSS.

Care is also required to insure that filter circuits do not communicate with digital signals on the mounting board, so acting as antennas.

Figure 17-11 shows an example of analog input circuit.

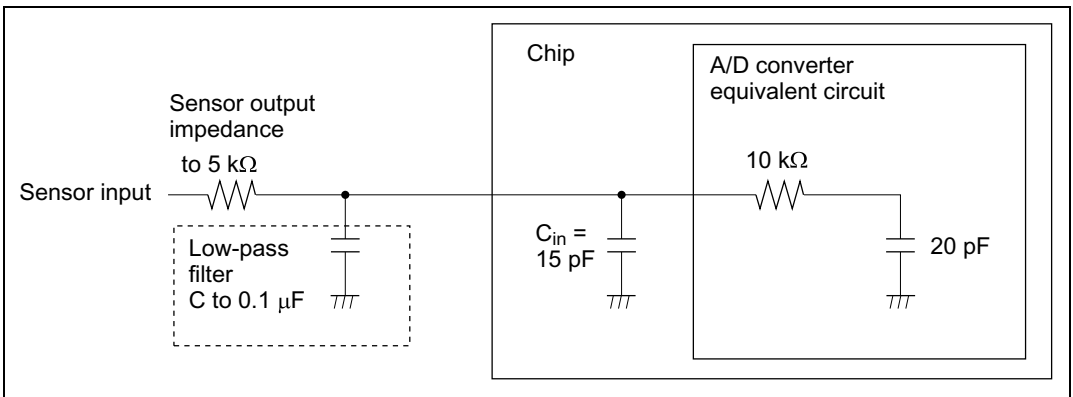

Figure 17-11 Example of Analog Input Circuit

Section 18 D/A Converter

Note: The H8S/2635 Group is not equipped with a D/A converter.

18.1 Overview

The chip has an on-chip D/A converter module with two channels.

18.1.1 Features

Features of the D/A converter module are listed below.

- Eight-bit resolution
- Two-channel output
- Maximum conversion time: 10 μ s (with 20-pF load capacitance)
- Output voltage: 0 V to Vref
- D/A output retention in software standby mode
- Possible to set module stop mode

Operation of D/A converter is disabled by initial values. It is possible to access the register by canceling module stop mode.

18.1.2 Block Diagram

Figure 18-1 shows a block diagram of the D/A converter.

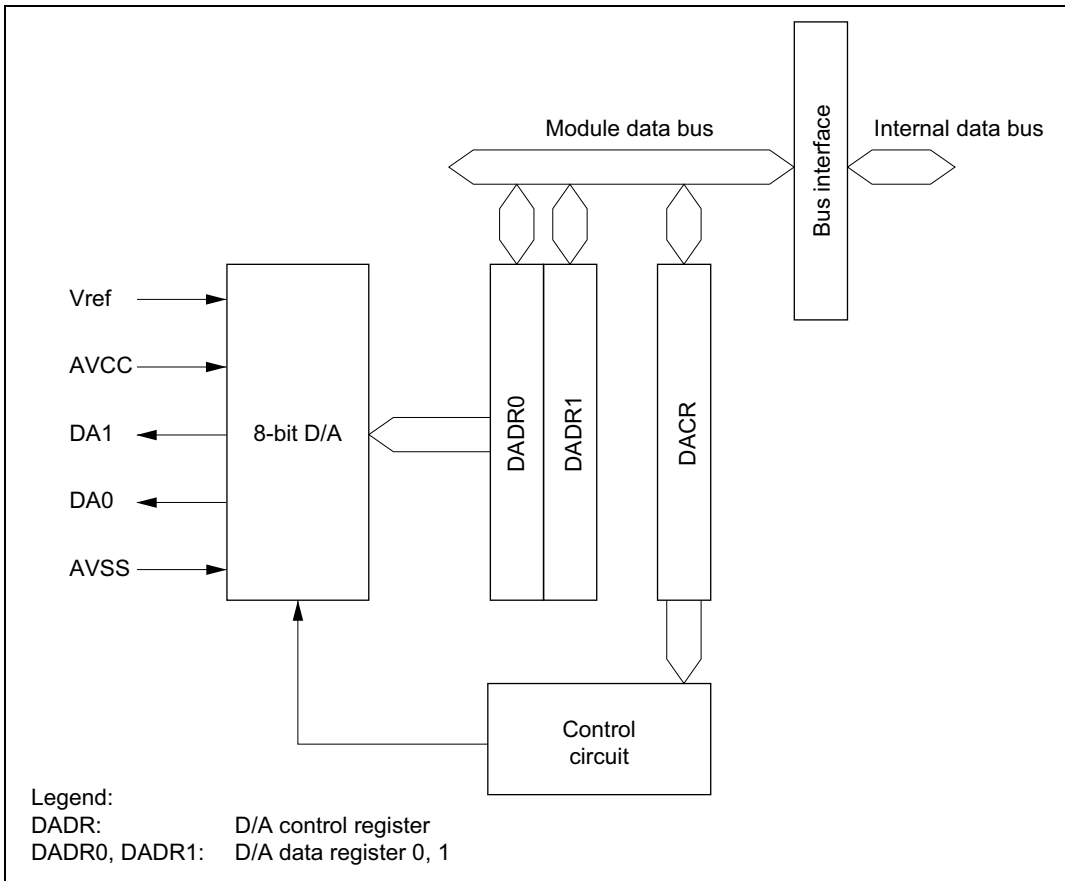

Figure 18-1 Block Diagram of D/A Converter

18.1.3 Input and Output Pins

Table 18-1 lists the input and output pins used by the D/A converter module.

Table 18-1 Input and Output Pins of D/A Converter Module

Name	Abbreviation	I/O	Function
Analog supply voltage	AVCC	Input	Power supply for analog circuits
Analog ground	AVSS	Input	Ground and reference voltage for analog circuits
Analog output 0	DA0	Output	Analog output channel 0
Analog output 1	DA1	Output	Analog output channel 1
Reference voltage	Vref	Input	Reference voltage of analog section

18.1.4 Register Configuration

Table 18-2 lists the registers of the D/A converter module.

Table 18-2 D/A Converter Registers

Channel	Name	Abbreviation	R/W	Initial Value	Address*
0, 1	D/A data register 0	DADR0	R/W	H'00	H'FFA4
	D/A data register 1	DADR1	R/W	H'00	H'FFA5
	D/A control register 01	DACR01	R/W	H'1F	H'FFA6
All	Module stop control register A	MSTPCRA	R/W	H'3F	H'FDF8

Note: * Lower 16 bits of the address.

18.2 Register Descriptions

18.2.1 D/A Data Registers 0, 1 (DADR0, DADR1)

Bit	7	6	5	4	3	2	1	0
Initial value	0	0	0	0	0	0	0	0
Read/Write	R/W	R/W	R/W	R/W	R/W	R/W	R/W	R/W

D/A data registers 0, 1 (DADR0, DADR1) are 8-bit readable/writable registers that store data to be converted. When analog output is enabled, the value in the D/A data register is converted and output continuously at the analog output pin.

The D/A data registers are initialized to H'00 by a reset and in hardware standby mode.

18.2.2 D/A Control Register 01 (DACR01)

Bit	7	6	5	4	3	2	1	0
	DAOE1	DAOE0	DAE	—	—	—	—	—
Initial value	0	0	0	1	1	1	1	1
Read/Write	R/W	R/W	R/W	—	—	—	—	—

DACR01 is an 8-bit readable/writable register that controls the operation of the D/A converter module.

DACR01 is initialized to H'1F by a reset and in hardware standby mode.

Bit 7—D/A Output Enable 1 (DAOE1): Controls D/A conversion and analog output.

Bit 7

DAOE1	Description
0	Analog output DA1 is disabled (Initial value)
1	D/A conversion is enabled on channel 1. Analog output DA1 is enabled

Bit 6—D/A Output Enable 0 (DAOE0): Controls D/A conversion and analog output.

Bit 6

DAOE0	Description
0	Analog output DA0 is disabled (Initial value)
1	D/A conversion is enabled on channel 0. Analog output DA0 is enabled

Bit 5—D/A Enable (DAE): Controls D/A conversion, in combination with bits DAOE0 and DAOE1. D/A conversion is controlled independently on channels 0 and 1 when DAE = 0. Channels 0 and 1 are controlled together when DAE = 1.

Output of the converted results is always controlled independently by DAOE0 and DAOE1.

Bit 7 DAOE1	Bit 6 DAOE0	Bit 5 DAE	D/A conversion
0	0	*	Disabled on channels 0 and 1
	1	0	Enabled on channel 0 Disabled on channel 1
		1	Enabled on channels 0 and 1
1	0	0	Disabled on channel 0 Enabled on channel 1
		1	Enabled on channels 0 and 1
	1	*	Enabled on channels 0 and 1

*: Don't care

If the chip enters software standby mode while D/A conversion is enabled, the D/A output is retained and the analog power supply current is the same as during D/A conversion. If it is necessary to reduce the analog power supply current in software standby mode, disable D/A output by clearing both the DAOE0 and DAOE1 bits to 0.

Bits 4 to 0—Reserved: These bits cannot be modified and are always read as 1.

18.2.3 Module Stop Control Register A (MSTPCRA)

MSTPCRA

Bit	:	7	6	5	4	3	2	1	0
		MSTPA7	MSTPA6	MSTPA5	MSTPA4	MSTPA3	MSTPA2	MSTPA1	MSTPA0
Initial value	:	0	0	1	1	1	1	1	1
R/W	:	R/W	R/W	R/W	R/W	R/W	R/W	R/W	R/W

MSTPCRA is an 8-bit readable/writable registers that performs module stop mode control. When the MSTPA2 is set to 1, the D/A converter halts and enters module stop mode at the end of the bus cycle. Register read/write is disenabled in module stop mode. See section 23A.5, 23B.5, Module Stop Mode, for details.

MSTPCRA is initialized to H'3F by a reset and in hardware standby mode. It is not initialized in software standby mode.

Bit 2—Module Stop (MSTPA2): Specifies D/A converter (channels 0 and 1) module stop mode.

Bit 2

MSTPA2	Description
0	D/A converter (channels 0 and 1) module stop mode is cleared
1	D/A converter (channels 0 and 1) module stop mode is set (Initial value)

18.3 Operation

The D/A converter module has one on-chip D/A converter circuits that can operate independently.

D/A conversion is performed continuously whenever enabled by the D/A control register (DACR). When a new value is written in DADR0 or DADR1, conversion of the new value begins immediately. The converted result is output by setting the DAOE0 or DAOE1 bit to 1.

An example of conversion on channel 0 is given next. Figure 18-2 shows the timing.

- Software writes the data to be converted in DADR0.
- D/A conversion begins when the DAOE0 bit in DACR is set to 1. After the elapse of the conversion time, analog output appears at the DA0 pin. Contents of DADR / $256 \times V_{ref}$
This output continues until a new value is written in DADR0 or the DAOE0 bit is cleared to 0.
- If a new value is written in DADR0, conversion begins immediately. Output of the converted result begins after the conversion time.
- When the DAOE0 bit is cleared to 0, DA0 becomes an input pin.

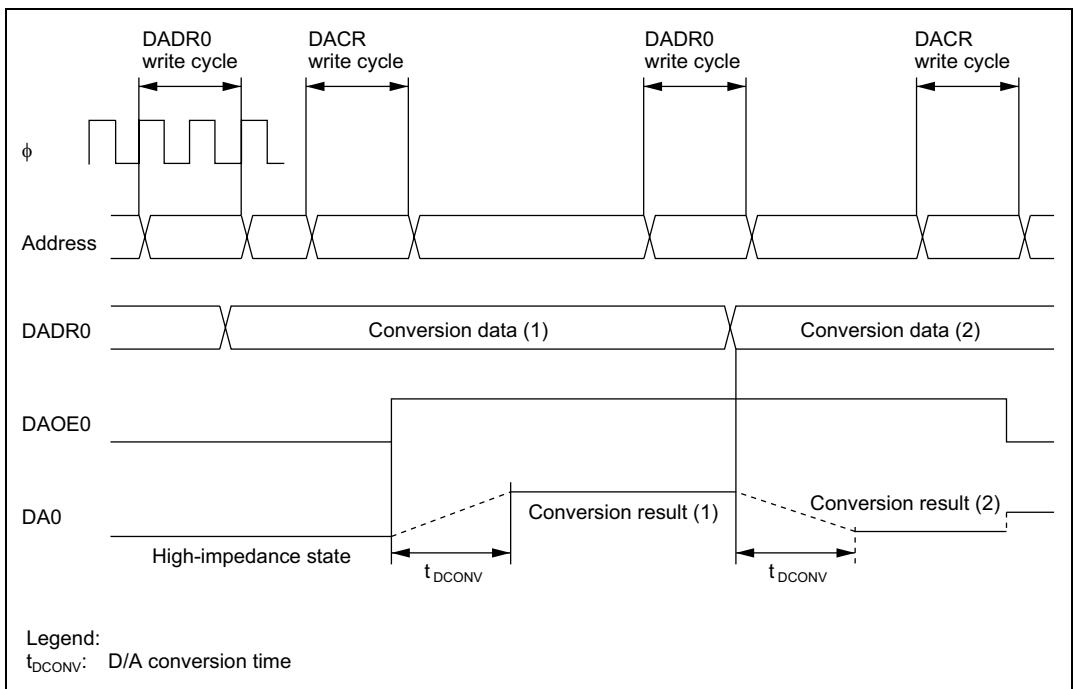

Figure 18-2 D/A Conversion (Example)

Section 19 Motor Control PWM Timer

Note: The H8S/2635 Group is not equipped with a DTC.

19.1 Overview

The chip has an on-chip motor control PWM (pulse width modulator) with a maximum capability of 16 pulse outputs.

19.1.1 Features

Features of the motor control PWM are given below.

- Maximum of 16 pulse outputs
 - Two 10-bit PWM channels, each with eight outputs.
 - Each channel is provided with a 10-bit counter (PWCNT) and cycle register (PWCYR).
 - Duty and output polarity can be set for each output.
- Buffered duty registers
 - Duty registers (PWDTR) are provided with buffer registers (PWBFR), with data transferred automatically every cycle.
 - Channel 1 has four duty registers and four buffer registers.
 - Channel 2 has eight duty registers and four buffer registers.
- 0% to 100% duty
 - A duty cycle of 0% to 100% can be set by means of a duty register setting.
- Five operating clocks
 - There is a choice of five operating clocks (ϕ , $\phi/2$, $\phi/4$, $\phi/8$, $\phi/16$).
- High-speed access via internal 16-bit-bus
 - High-speed access is possible via a 16-bit bus interface.
- Two interrupt sources
 - An interrupt can be requested independently for each channel by a cycle register compare match.
- Automatic transfer of register data
 - Block transfer and one-word data transfer are possible by activating the data transfer controller (DTC).
- Module stop mode
 - As the initial setting, PWM operation is halted. Register access is enabled by clearing module stop mode.

19.1.2 Block Diagram

Figure 19-1 shows a block diagram of PWM channel 1.

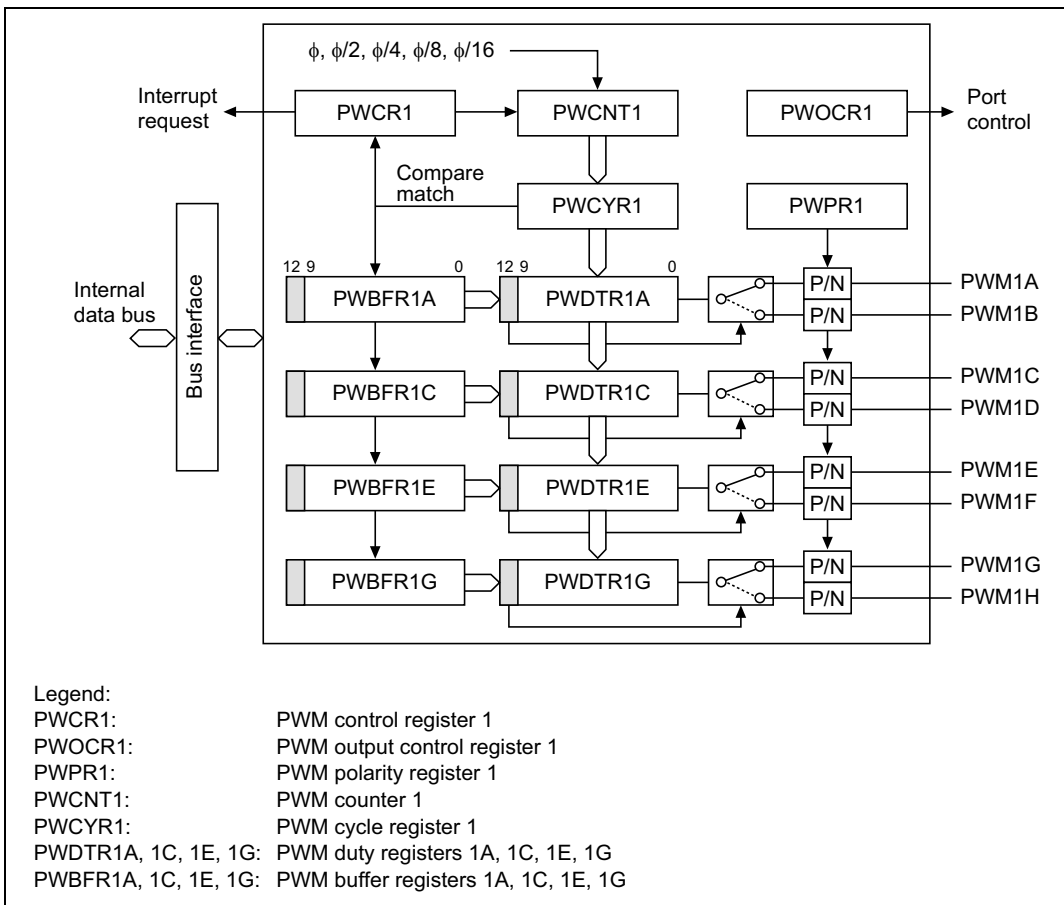

Figure 19-1 Block Diagram of PWM Channel 1

Figure 19-2 shows a block diagram of PWM channel 2.

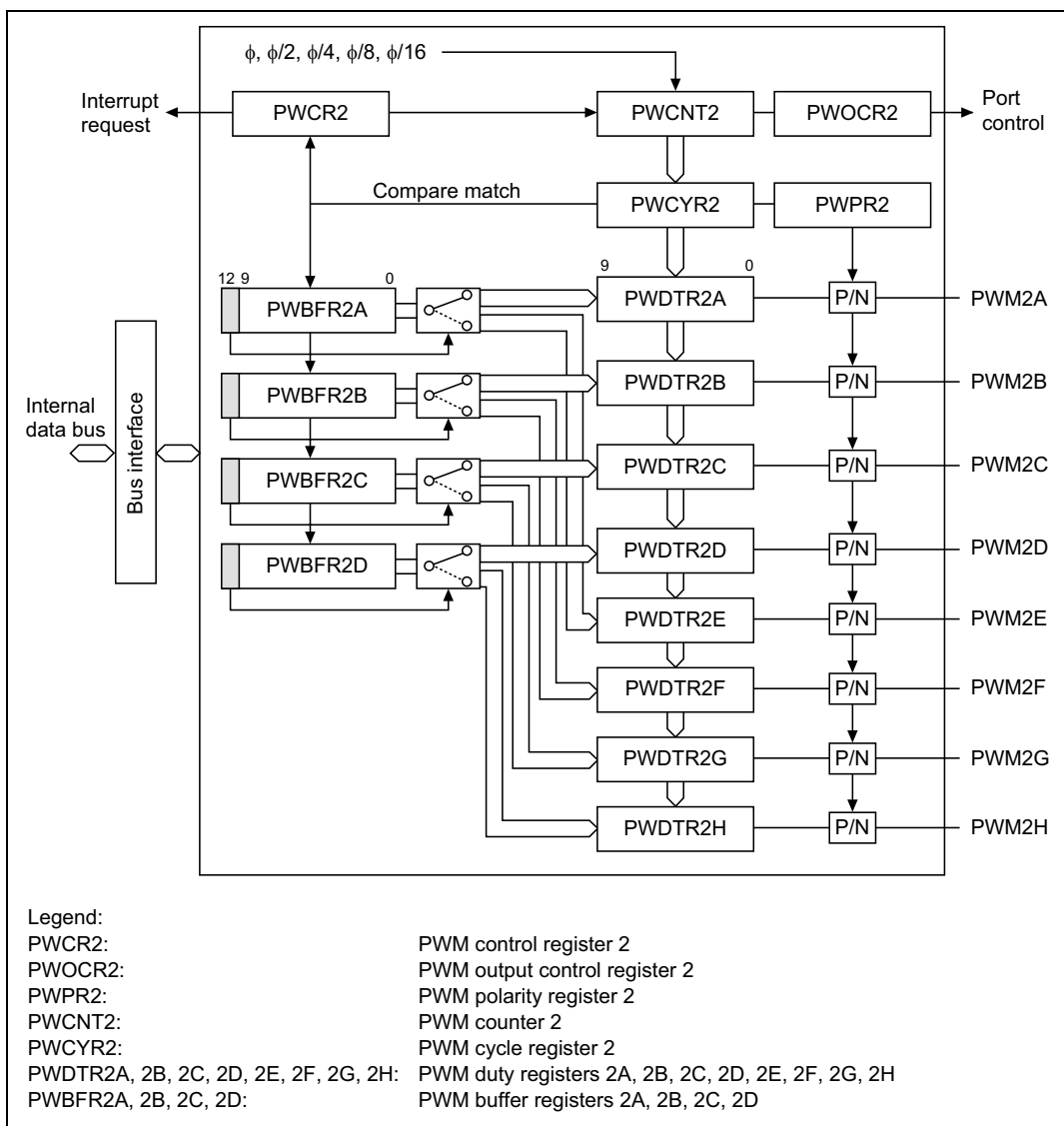

Figure 19-2 Block Diagram of PWM Channel 2

19.1.3 Pin Configuration

Table 19-1 shows the PWM pin configuration.

Table 19-1 PWM Pin Configuration

Name	Abbrev.	I/O	Function
PWM output pin 1A	PWM1A	Output	Channel 1A PWM output
PWM output pin 1B	PWM1B	Output	Channel 1B PWM output
PWM output pin 1C	PWM1C	Output	Channel 1C PWM output
PWM output pin 1D	PWM1D	Output	Channel 1D PWM output
PWM output pin 1E	PWM1E	Output	Channel 1E PWM output
PWM output pin 1F	PWM1F	Output	Channel 1F PWM output
PWM output pin 1G	PWM1G	Output	Channel 1G PWM output
PWM output pin 1H	PWM1H	Output	Channel 1H PWM output
PWM output pin 2A	PWM2A	Output	Channel 2A PWM output
PWM output pin 2B	PWM2B	Output	Channel 2B PWM output
PWM output pin 2C	PWM2C	Output	Channel 2C PWM output
PWM output pin 2D	PWM2D	Output	Channel 2D PWM output
PWM output pin 2E	PWM2E	Output	Channel 2E PWM output
PWM output pin 2F	PWM2F	Output	Channel 2F PWM output
PWM output pin 2G	PWM2G	Output	Channel 2G PWM output
PWM output pin 2H	PWM2H	Output	Channel 2H PWM output

19.1.4 Register Configuration

Table 19-2 shows the register configuration of the PWM.

Table 19-2 PWM Registers

Channel	Name	Abbrev.	R/W	Initial Value	Address*1
1	PWM control register 1	PWCR1	R/W	H'C0	H'FC00
	PWM output control register 1	PWOCR1	R/W	H'00	H'FC02
	PWM polarity register 1	PWPR1	R/W	H'00	H'FC04
	PWM cycle register 1	PWCYR1	R/W	H'FFFF	H'FC06
	PWM buffer register 1A	PWBFR1A	R/W	H'EC00	H'FC08
	PWM buffer register 1C	PWBFR1C	R/W	H'EC00	H'FC0A
	PWM buffer register 1E	PWBFR1E	R/W	H'EC00	H'FC0C
	PWM buffer register 1G	PWBFR1G	R/W	H'EC00	H'FC0E
2	PWM control register 2	PWCR2	R/W	H'C0	H'FC10
	PWM output control register 2	PWOCR2	R/W	H'00	H'FC12
	PWM polarity register 2	PWPR2	R/W	H'00	H'FC14
	PWM cycle register 2	PWCYR2	R/W	H'FFFF	H'FC16
	PWM buffer register 2A	PWBFR2A	R/W	H'EC00	H'FC18
	PWM buffer register 2B	PWBFR2B	R/W	H'EC00	H'FC1A
	PWM buffer register 2C	PWBFR2C	R/W	H'EC00	H'FC1C
	PWM buffer register 2D	PWBFR2D	R/W	H'EC00	H'FC1E
All	Module stop control register D	MSTPCRD	R/W	B'11*****	H'FC60

Note: 1. Lower 16 bits of the address.

19.2 Register Descriptions

19.2.1 PWM Control Registers 1 and 2 (PWCR1, PWCR2)

Bit	7	6	5	4	3	2	1	0
	—	—	IE	CMF	CST	CKS2	CKS1	CKS0
Initial value	1	1	0	0	0	0	0	0
Read/Write	—	—	R/W	R/W*	R/W	R/W	R/W	R/W

Note: * Only 0 can be written, to clear the flag.

PWCR is an 8-bit read/write register that performs interrupt enabling, starting/stopping, and counter (PWCNT) clock selection. It also contains a flag that indicates a compare match with the cycle register (PWCYR). PWCR1 is the channel 1 register, and PWCR2 is the channel 2 register.

PWCR is initialized to H'C0 upon reset, and in standby mode, watch mode*, subactive mode*, subsleep mode*, and module stop mode.

Note: * Subclock functions (subactive mode, subsleep mode, and watch mode) are available in the U-mask and W-mask versions only.

These functions cannot be used with the other versions.

Bits 7 and 6—Reserved: They are always read as 1 and cannot be modified.

Bit 5—Interrupt Enable (IE): Bit 5 selects enabling or disabling of an interrupt in the event of a compare match with the PWCYR register for the corresponding channel.

Bit 5: IE	Description
0	Interrupt disabled (Initial value)
1	Interrupt enabled

Bit 4—Compare Match Flag (CMF): Bit 4 indicates the occurrence of a compare match with the PWCYR register for the corresponding channel.

Bit 4: CMF	Description
0	[Clearing conditions] (Initial value) <ul style="list-style-type: none"> When 0 is written to CMF after reading CMF = 1 When the DTC is activated by a compare match interrupt, and the DISEL bit in the DTC's MRB register is 0
1	[Setting condition] <ul style="list-style-type: none"> When PWCNT = PWCYR

Bit 3—Counter Start (CST): Bit 3 selects starting or stopping of the PWCNT counter for the corresponding channel.

Bit 3: CST	Description
0	PWCNT is stopped (Initial value)
1	PWCNT is started

Bits 2 to 0—Clock Select (CKS): Bits 2 to 0 select the clock for the PWCNT counter in the corresponding channel.

Bit 2: CKS2	Bit 1: CKS1	Bit 0: CKS0	Description
0	0	0	Internal clock: counts on $\phi/1$ (Initial value)
		1	Internal clock: counts on $\phi/2$
	1	0	Internal clock: counts on $\phi/4$
		1	Internal clock: counts on $\phi/8$
1	*	*	Internal clock: counts on $\phi/16$

*: Don't care

19.2.2 PWM Output Control Registers 1 and 2 (PWOCR1, PWOCR2)

PWOCR1

Bit	7	6	5	4	3	2	1	0
	OE1H	OE1G	OE1F	OE1E	OE1D	OE1C	OE1B	OE1A
Initial value	0	0	0	0	0	0	0	0
Read/Write	R/W	R/W	R/W	R/W	R/W	R/W	R/W	R/W

PWOCR2

Bit	7	6	5	4	3	2	1	0
	OE2H	OE2G	OE2F	OE2E	OE2D	OE2C	OE2B	OE2A
Initial value	0	0	0	0	0	0	0	0
Read/Write	R/W	R/W	R/W	R/W	R/W	R/W	R/W	R/W

PWOCR is an 8-bit read/write register that enables or disables PWM output. PWOCR1 controls outputs PWM1H to PWM1A, and PWOCR2 controls outputs PWM2H to PWM2A.

PWOCR is initialized to H'00 upon reset, and in standby mode, watch mode*, subactive mode*, subsleep mode*, and module stop mode.

Note: * Subclock functions (subactive mode, subsleep mode, and watch mode) are available in the U-mask and W-mask versions, and H8S/2635 Group only.

These functions cannot be used with the other versions.

Bits 7 to 0—Output Enable (OE): Each of these bits enables or disables the corresponding PWM output.

Bits 7 to 0:

OE	Description
0	PWM output is disabled (Initial value)
1	PWM output is enabled

19.2.3 PWM Polarity Registers 1 and 2 (PWPR1, PWPR2)

PWPR1

Bit	7	6	5	4	3	2	1	0
	OPS1H	OPS1G	OPS1F	OPS1E	OPS1D	OPS1C	OPS1B	OPS1A
Initial value	0	0	0	0	0	0	0	0
Read/Write	R/W	R/W	R/W	R/W	R/W	R/W	R/W	R/W

PWPR2

Bit	7	6	5	4	3	2	1	0
	OPS2H	OPS2G	OPS2F	OPS2E	OPS2D	OPS2C	OPS2B	OPS2A
Initial value	0	0	0	0	0	0	0	0
Read/Write	R/W	R/W	R/W	R/W	R/W	R/W	R/W	R/W

PWPR is an 8-bit read/write register that selects the PWM output polarity. PWPR1 controls outputs PWM1H to PWM1A, and PWPR2 controls outputs PWM2H to PWM2A.

PWPR is initialized to H'00 upon reset, and in standby mode, watch mode*, subactive mode*, subsleep mode*, and module stop mode.

Note: * Subclock functions (subactive mode, subsleep mode, and watch mode) are available in the U-mask and W-mask versions, and H8S/2635 Group only.

These functions cannot be used with the other versions.

Bits 7 to 0—Output Polarity Select (OPS): Each of these bits selects the polarity of the corresponding PWM output.

Bits 7 to 0:

OPS	Description
0	PWM direct output (Initial value)
1	PWM inverse output

19.2.4 PWM Counters 1 and 2 (PWCNT1, PWCNT2)

Bit	15	14	13	12	11	10	9	8	7	6	5	4	3	2	1	0
	—	—	—	—	—	—										
Initial value	1	1	1	1	1	1	0	0	0	0	0	0	0	0	0	0
Read/Write	—	—	—	—	—	—	—	—	—	—	—	—	—	—	—	—

PWCNT is a 10-bit up-counter incremented by the input clock. The input clock is selected by clock select bits 2 to 0 (CKS2 to CKS0) in PWCR.

PWCNT1 is used as the channel 1 time base, and PWCNT2 as the channel 2 time base.

PWCNT is initialized to H'FC00 when the counter start bit (CST) in PWCR is cleared to 0, and also upon reset and in standby mode, watch mode*, subactive mode*, subsleep mode*, and module stop mode.

Note: * Subclock functions (subactive mode, subsleep mode, and watch mode) are available in the U-mask and W-mask versions, and H8S/2635 Group only.
These functions cannot be used with the other versions.

19.2.5 PWM Cycle Registers 1 and 2 (PWCYR1, PWCYR2)

Bit	15	14	13	12	11	10	9	8	7	6	5	4	3	2	1	0
Initial value	1	1	1	1	1	1	1	1	1	1	1	1	1	1	1	1
Read/Write	—	—	—	—	—	—	R/W	R/W	R/W	R/W	R/W	R/W	R/W	R/W	R/W	R/W

PWCYR is a 16-bit read/write register that sets the PWM conversion cycle. When a PWCYR compare match occurs, PWCNT is cleared and data is transferred from the buffer register (PWBFR) to the duty register (PWDTR). PWCYR1 is used for the channel 1 conversion cycle setting, and PWCYR2 for the channel 2 conversion cycle setting.

PWCYR should be written to only while PWCNT is stopped. A value of H'FC00 must not be set.

PWCYR is initialized to H'FFFF upon reset, and in standby mode, watch mode*, subactive mode*, subsleep mode*, and module stop mode.

Note: * Subclock functions (subactive mode, subsleep mode, and watch mode) are available in the U-mask and W-mask versions, and H8S/2635 Group only.

These functions cannot be used with the other versions.

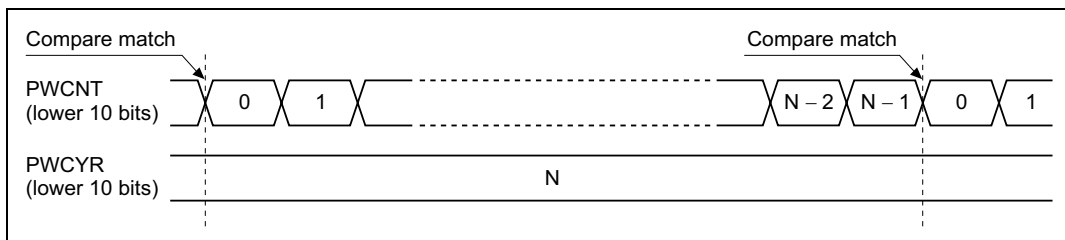

Figure 19-3 Cycle Register Compare Match

19.2.6 PWM Duty Registers 1A, 1C, 1E, 1G (PWDTR1A, 1C, 1E, 1G)

Bit	15	14	13	12	11	10	9	8	7	6	5	4	3	2	1	0
	—	—	—	OTS	—	—	DT9	DT8	DT7	DT6	DT5	DT4	DT3	DT2	DT1	DT0
Initial value	1	1	1	0	1	1	0	0	0	0	0	0	0	0	0	0
Read/Write	—	—	—	—	—	—	—	—	—	—	—	—	—	—	—	—

There are four PWDTR1x registers (PWDTR1A, 1C, 1E, 1G). PWDTR1A is used for outputs PWM1A and PWM1B, PWDTR1C for outputs PWM1C and PWM1D, PWDTR1E for outputs PWM1E and PWM1F, and PWDTR1G for outputs PWM1G and PWM1H.

PWDTR1 cannot be read or written to directly. When a PWCYR1 compare match occurs, data is transferred from buffer register 1 (PWBFR1) to PWDTR1.

PWDTR1x is initialized to H'EC00 when the counter start bit (CST) in PWCR1 is cleared to 0, and also upon reset and in standby mode, watch mode*, subactive mode*, subsleep mode*, and module stop mode.

Note: * Subclock functions (subactive mode, subsleep mode, and watch mode) are available in the U-mask and W-mask versions, and H8S/2635 Group only.

These functions cannot be used with the other versions.

Bits 15 to 13—Reserved: These bits cannot be read from or written to.

Bit 12—Output Terminal Select (OTS): Bit 12 selects the pin used for PWM output according to the value in bit 12 in the buffer register that is transferred by a PWCYR1 compare match. Unselected pins output a low level (or a high level when the corresponding bit in PWPR1 is set to 1).

Register	Bit 12: OTS	Description	
PWDTR1A	0	PWM1A output selected	(Initial value)
	1	PWM1B output selected	
PWDTR1C	0	PWM1C output selected	(Initial value)
	1	PWM1D output selected	
PWDTR1E	0	PWM1E output selected	(Initial value)
	1	PWM1F output selected	
PWDTR1G	0	PWM1G output selected	(Initial value)
	1	PWM1H output selected	

Bits 11 and 10—Reserved: These bits cannot be read from or written to.

Bits 9 to 0—Duty (DT): Bits 9 to 0 set the PWM output duty according to the values in bits 9 to 0 in the buffer register that is transferred by a PWCYR1 compare match. A high level (or a low level when the corresponding bit in PWPR1 is set to 1) is output from the time PWCNT1 is cleared by a PWCYR1 compare match until a PWDTR1 compare match occurs. When all the bits are 0, there is no high-level output period (no low-level output period when the corresponding bit in PWPR1 is set to 1).

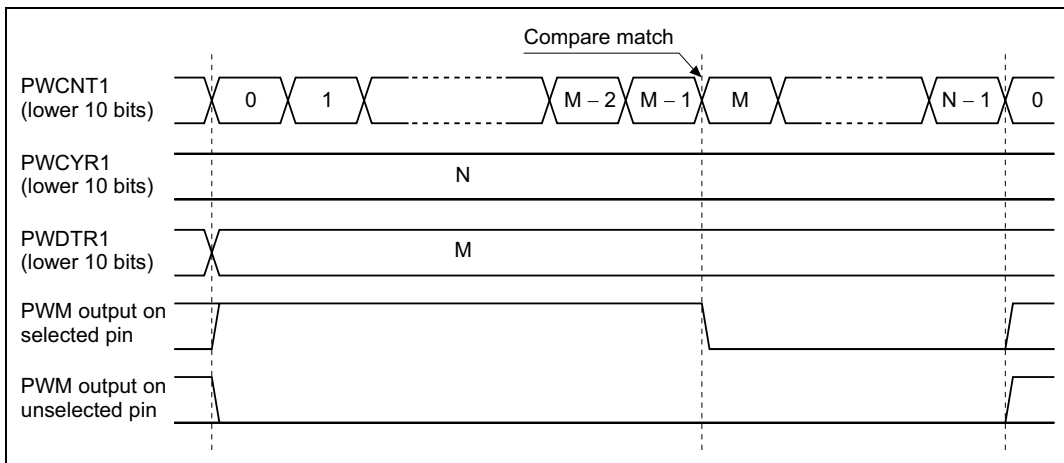

Figure 19-4 Duty Register Compare Match (OPS = 0 in PWPR1)

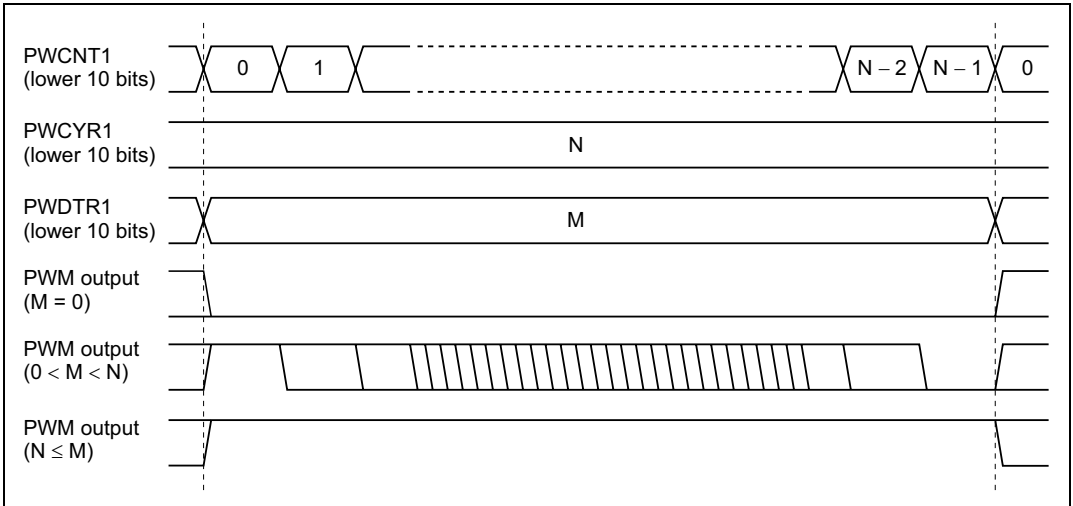

Figure 19-5 Differences in PWM Output According to Duty Register Set Value (OPS = 0 in PWPR1)

19.2.7 PWM Buffer Registers 1A, 1C, 1E, 1G (PWBFR1A, 1C, 1E, 1G)

Bit	15	14	13	12	11	10	9	8	7	6	5	4	3	2	1	0
	—	—	—	OTS	—	—	DT9	DT8	DT7	DT6	DT5	DT4	DT3	DT2	DT1	DT0
Initial value	1	1	1	0	1	1	0	0	0	0	0	0	0	0	0	0
Read/Write	—	—	—	R/W	—	—	R/W	R/W	R/W	R/W	R/W	R/W	R/W	R/W	R/W	R/W

There are four 16-bit read/write PWBFR1 registers (PWBFR1A, 1C, 1E, 1G). When a PWCYR1 compare match occurs, data is transferred from PWBFR1A to PWDTR1A, from PWBFR1C to PWDTR1C, from PWBFR1E to PWDTR1E, and from PWBFR1G to PWDTR1G.

PWBFR1 is initialized to H'EC00 upon reset, and in standby mode, watch mode*, subactive mode*, subsleep mode*, and module stop mode.

Note: * Subclock functions (subactive mode, subsleep mode, and watch mode) are available in the U-mask and W-mask versions, and H8S/2635 Group only.

These functions cannot be used with the other versions.

Bits 15 to 13—Reserved: They are always read as 1 and cannot be modified.

Bit 12—Output Terminal Select (OTS): Bit 12 is the data transferred to bit 12 of PWDTR1.

Bits 11 and 10—Reserved: They are always read as 1 and cannot be modified.

Bits 9 to 0—Duty (DT): Bits 9 to 0 comprise the data transferred to bits 9 to 0 in PWDTR1.

19.2.8 PWM Duty Registers 2A to 2H (PWDTR2A to PWDTR2H)

Bit	15	14	13	12	11	10	9	8	7	6	5	4	3	2	1	0
	—	—	—	—	—	—	DT9	DT8	DT7	DT6	DT5	DT4	DT3	DT2	DT1	DT0
Initial value	1	1	1	0	1	1	0	0	0	0	0	0	0	0	0	0
Read/Write	—	—	—	—	—	—	—	—	—	—	—	—	—	—	—	—

There are eight PWDTR2 registers (PWDTR2A to PWDTR2H). PWDTR2A is used for output PWM2A, PWDTR2B for output PWM2B, PWDTR2C for output PWM2C, PWDTR2D for output PWM2D, PWDTR2E for output PWM2E, PWDTR2F for output PWM2F, PWDTR2G for output PWM2G, and PWDTR2H for output PWM2H.

PWDTR2 cannot be read or written to directly. When a PWCYR2 compare match occurs, data is transferred from buffer register 2 (PWBFR2) to PWDTR2.

PWDTR2 is initialized to H'EC00 when the counter start bit (CST) in PWCR2 is cleared to 0, and also upon reset and in standby mode, watch mode*, subactive mode*, subsleep mode*, and module stop mode.

Note: * Subclock functions (subactive mode, subsleep mode, and watch mode) are available in the U-mask and W-mask versions, and H8S/2635 Group only.
These functions cannot be used with the other versions.

Bits 15 to 10—Reserved: These bits cannot be read from or written to.

Bits 9 to 0—Duty (DT): Bits 9 to 0 set the PWM output duty according to the values in bits 9 to 0 in the buffer register that is transferred by a PWCYR2 compare match. A high level (or a low level when the corresponding bit in PWPR2 is set to 1) is output from the time PWCNT2 is cleared by a PWCYR2 compare match until a PWDTR2 compare match occurs. When all the bits are 0, there is no high-level output period (no low-level output period when the corresponding bit in PWPR2 is set to 1).

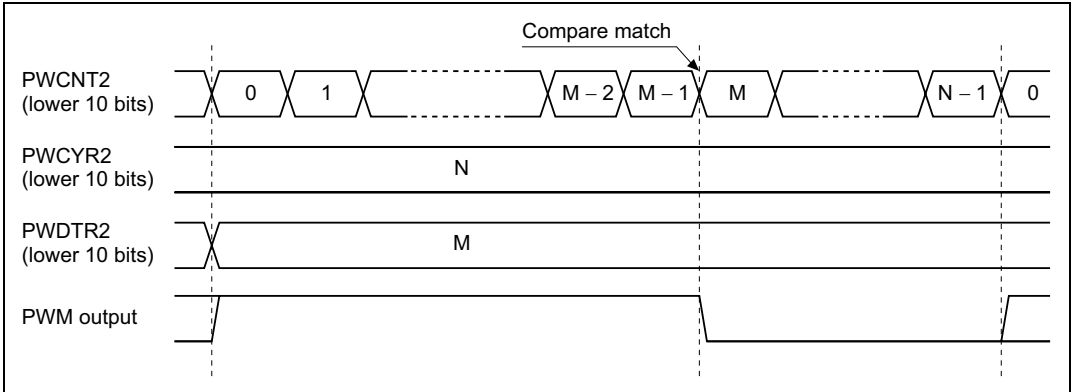

Figure 19-6 Duty Register Compare Match (OPS = 0 in PWPR2)

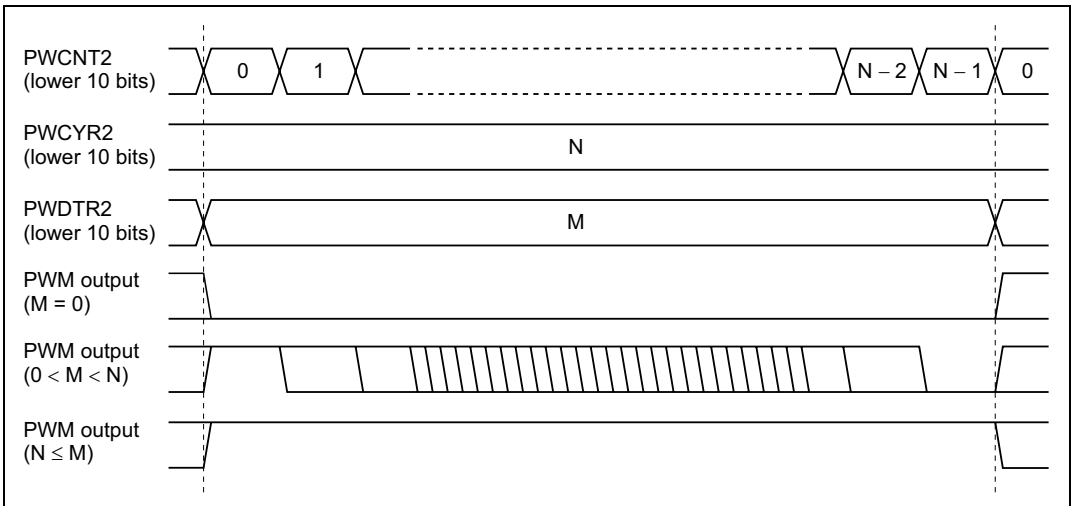

Figure 19-7 Differences in PWM Output According to Duty Register Set Value (OPS = 0 in PWPR2)

19.2.9 PWM Buffer Registers 2A to 2D (PWBFR2A to PWBFR2D)

Bit	15	14	13	12	11	10	9	8	7	6	5	4	3	2	1	0
	—	—	—	TDS	—	—	DT9	DT8	DT7	DT6	DT5	DT4	DT3	DT2	DT1	DT0
Initial value	1	1	1	0	1	1	0	0	0	0	0	0	0	0	0	0
Read/Write	—	—	—	R/W	—	—	R/W	R/W	R/W	R/W	R/W	R/W	R/W	R/W	R/W	R/W

There are four 16-bit read/write PWBFR2 registers (PWBFR2A to PWBFR2D). When a PWCYR2 compare match occurs, data is transferred from PWBFR2A to PWDTR2A or PWDTR2E, from PWBFR2B to PWDTR2B or PWDTR2F, from PWBFR2C to PWDTR2C or PWDTR2G, and from PWBFR2D to PWDTR2D or PWDTR2H. The transfer destination is determined by the value of the TDS bit.

PWBFR2 is initialized to H'EC00 upon reset, and in standby mode, watch mode*, subactive mode*, subsleep mode*, and module stop mode.

Note: * Subclock functions (subactive mode, subsleep mode, and watch mode) are available in the U-mask and W-mask versions, and H8S/2635 Group only.

These functions cannot be used with the other versions.

Bits 15 to 13—Reserved: They are always read as 1 and cannot be modified.

Bit 12—Transfer Destination Select (TDS): Bit 12 selects the PWDTR2 register to which data is to be transferred.

Register	Bit 12: TDS	Description
PWBFR2A	0	PWDTR2A selected (Initial value)
	1	PWDTR2E selected
PWBFR2B	0	PWDTR2B selected (Initial value)
	1	PWDTR2F selected
PWBFR2C	0	PWDTR2C selected (Initial value)
	1	PWDTR2G selected
PWBFR2D	0	PWDTR2D selected (Initial value)
	1	PWDTR2H selected

Bits 11 and 10—Reserved: They are always read as 1 and cannot be modified.

Bits 9 to 0—Duty (DT): Bits 9 to 0 comprise the data transferred to bits 9 to 0 in PWDTR2.

19.2.10 Module Stop Control Register D (MSTPCRD)

Bit	7	6	5	4	3	2	1	0
	MSTPD7	MSTPD6	MSTPD5	MSTPD4	MSTPD3	MSTPD2	MSTPD1	MSTPD0
Initial value	1	1	undefined	undefined	undefined	undefined	undefined	undefined
Read/Write	R/W	R/W	—	—	—	—	—	—

MSTPCRD is an 8-bit read/write register that performs module stop mode control.

When the MSTPD7 bit is set to 1, PWM timer operation is stopped at the end of the bus cycle, and module stop mode is entered. For details, see section 23A.5, 23B.5, Module Stop Mode.

MSTPCRD is initialized by a reset and in hardware standby mode. It is not initialized by a manual reset or in software standby mode.

Bit 7—Module Stop (MSTPD7): Bit 7 specifies the PWM module stop mode.

Bit 7: MSTPD7	Description
0	PWM module stop mode is cleared
1	PWM module stop mode is set (Initial value)

19.3 Bus Master Interface

19.3.1 16-Bit Data Registers

PWCYR1/2, PWBFR1A/C/E/G, and PWBFR2A/B/C/D are 16-bit registers. These registers are linked to the bus master by a 16-bit data bus, and can be read or written in 16-bit units. They cannot be read by 8-bit access; 16-bit access must always be used.

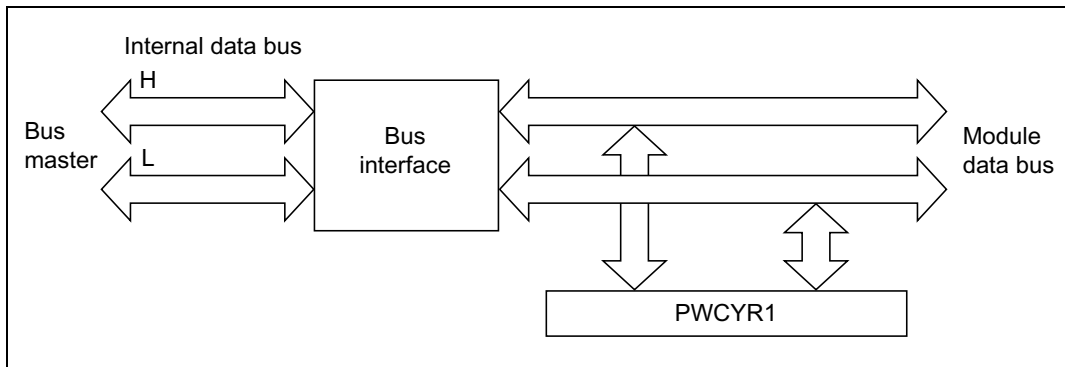

Figure 19-8 16-Bit Register Access Operation (Bus Master ↔ PWCYR1 (16 Bits))

19.3.2 8-Bit Data Registers

PWCR1/2, PWOCR1/2, and PWPR1/2 are 8-bit registers that can be read and written to in 8-bit units. These registers are linked to the bus master by a 16-bit data bus, and can be read or written by 16-bit access; in this case, the lower 8 bits will always be read as H'FF.

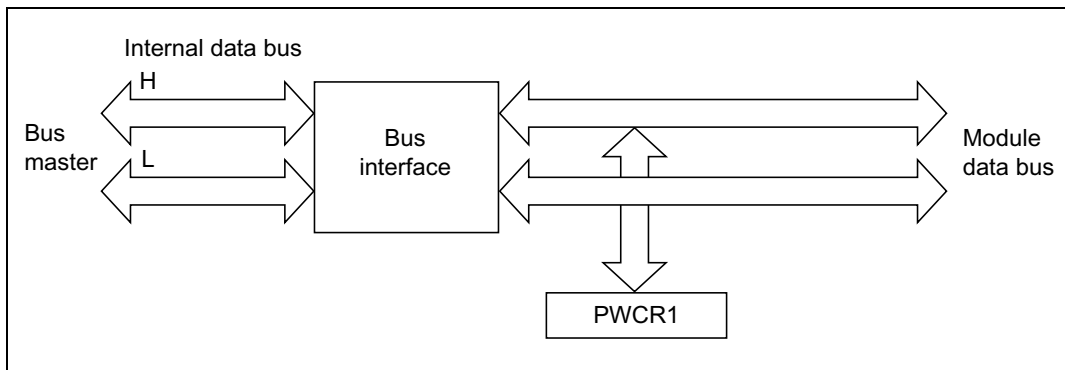

Figure 19-9 8-Bit Register Access Operation (Bus Master ↔ PWCR1 (Upper 8 Bits))

19.4 Operation

19.4.1 PWM Channel 1 Operation

PWM waveforms are output from pins PWM1A to PWM1H as shown in figure 19-10.

Initial Settings: Set the PWM output polarity in PWPR1; enable the pins for PWM output with PWOCR1; select the clock to be input to PWCNT1 with bits CKS2 to CKS0 in PWCR1; set the PWM conversion cycle in PWCYR1; and set the first frame of data in PWBFR1A, PWBFR1C, PWBFR1E, and PWBFR1G.

Activation: When the CST bit in PWCR1 is set to 1, a compare match between PWCNT1 and PWCYR1 is generated. Data is transferred from PWBFR1A to PWDTR1A, from PWBFR1C to PWDTR1C, from PWBFR1E to PWDTR1E, and from PWBFR1G to PWDTR1G. PWCNT1 starts counting up. At the same time the CMF bit in PWCR1 is set, so that, if the IE bit in PWCR1 has been set, an interrupt can be requested or the DTC can be activated.

Waveform Output: The PWM outputs selected by the OTS bits in PWDTR1A/C/E/G go high when a compare match occurs between PWCNT1 and PWCYR1. The PWM outputs not selected by the OTS bits are low. When a compare match occurs between PWCNT1 and PWDTR1A/C/E/G, the corresponding PWM output goes low. If the corresponding bit in PWPR1 is set to 1, the output is inverted.

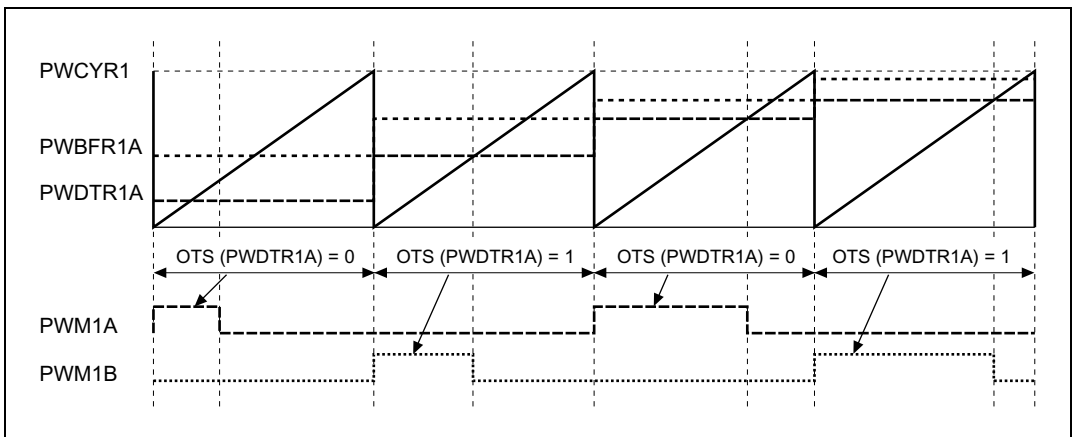

Figure 19-10 PWM Channel 1 Operation

Next Frame: When a compare match occurs between PWCNT1 and PWCYR1, data is transferred from PWBFR1A to PWDTR1A, from PWBFR1C to PWDTR1C, from PWBFR1E to PWDTR1E, and from PWBFR1G to PWDTR1G. PWCNT1 is reset and starts counting up from H'000. The CMF bit in PWCR1 is set, and if the IE bit in PWCR1 has been set, an interrupt can be requested or the DTC can be activated.

Stopping: When the CST bit in PWCR1 is cleared to 0, PWCNT1 is reset and stops. All PWM outputs go low (or high if the corresponding bit in PWPR1 is set to 1).

19.4.2 PWM Channel 2 Operation

PWM waveforms are output from pins PWM2A to PWM2H as shown in figure 19-11.

Initial Settings: Set the PWM output polarity in PWPR2; enable the pins for PWM output with PWOCR2; select the clock to be input to PWCNT2 with bits CKS2 to CKS0 in PWCR2; set the PWM conversion cycle in PWCYR2; and set the first frame of data in PWBFR2A, PWBFR2B, PWBFR2C, and PWBFR2D.

Activation: When the CST bit in PWCR2 is set to 1, a compare match between PWCNT2 and PWCYR2 is generated. Data is transferred from PWBFR2A to PWDTR2A or PWDTR2E, from PWBFR2B to PWDTR2B or PWDTR2F, from PWBFR2C to PWDTR2C or PWDTR2G, and from PWBFR2D to PWDTR2D or PWDTR2H, according to the value of the TDS bit. PWCNT2 starts counting up. At the same time the CMF bit in PWCR2 is set, so that, if the IE bit in PWCR2 has been set, an interrupt can be requested or the DTC can be activated.

Waveform Output: The PWM outputs go high when a compare match occurs between PWCNT2 and PWCYR2. When a compare match occurs between PWCNT2 and PWDTR2A to PWDTR2H, the corresponding PWM output goes low. If the corresponding bit in PWPR2 is set to 1, the output is inverted.

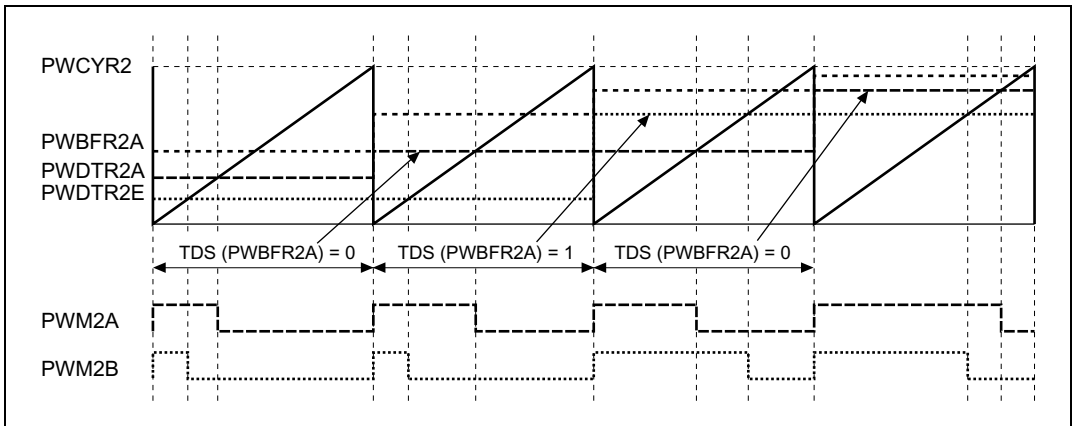

Figure 19-11 PWM Channel 2 Operation

Next Frame: When a compare match occurs between PWCNT2 and PWCYR2, data is transferred from PWBFR2A to PWDTR2A or PWDTR2E, from PWBFR2B to PWDTR2B or PWDTR2F, from PWBFR2C to PWDTR2C or PWDTR2G, and from PWBFR2D to PWDTR2D or PWDTR2H, according to the value of the TDS bit. PWCNT2 is reset and starts counting up from H'000. The CMF bit in PWCR2 is set, and if the IE bit in PWCR2 has been set, an interrupt can be requested or the DTC can be activated.

Stopping: When the CST bit in PWCR2 is cleared to 0, PWCNT2 is reset and stops. PWDTR2A to PWDTR2H are reset. All PWM outputs go low (or high if the corresponding bit in PWPR2 is set to 1).

19.5 Usage Note

Contention between Buffer Register Write and Compare Match

If a PWBFR write is performed in the state immediately after a cycle register compare match, the PWM output does not change, but as the duty register is also rewritten at the same time as the buffer register, normal PWM output will not be achieved.

If a PWBFR write is performed in the state immediately after a cycle register compare match, the buffer register and duty register are overwritten. PWM output changed by the cycle register compare match is not changed in the overwrite of the duty register due to contention. This may result in unanticipated duty output. In the case of channel 2, the duty register used as the transfer destination is selected by the TDS bit of the buffer register when an overwrite of the duty register occurs due to contention. This can also result in an unintended overwrite of the duty register.

Buffer register rewriting must be completed before automatic transfer by the DTC* (data transfer controller), exception handling due to a compare match interrupt, or the occurrence of a cycle register compare match on detection of the rise of CMF (compare match flag) in PWCR.

Note: * The DTC is not implemented in the H8S/2635 and H8S/2634.

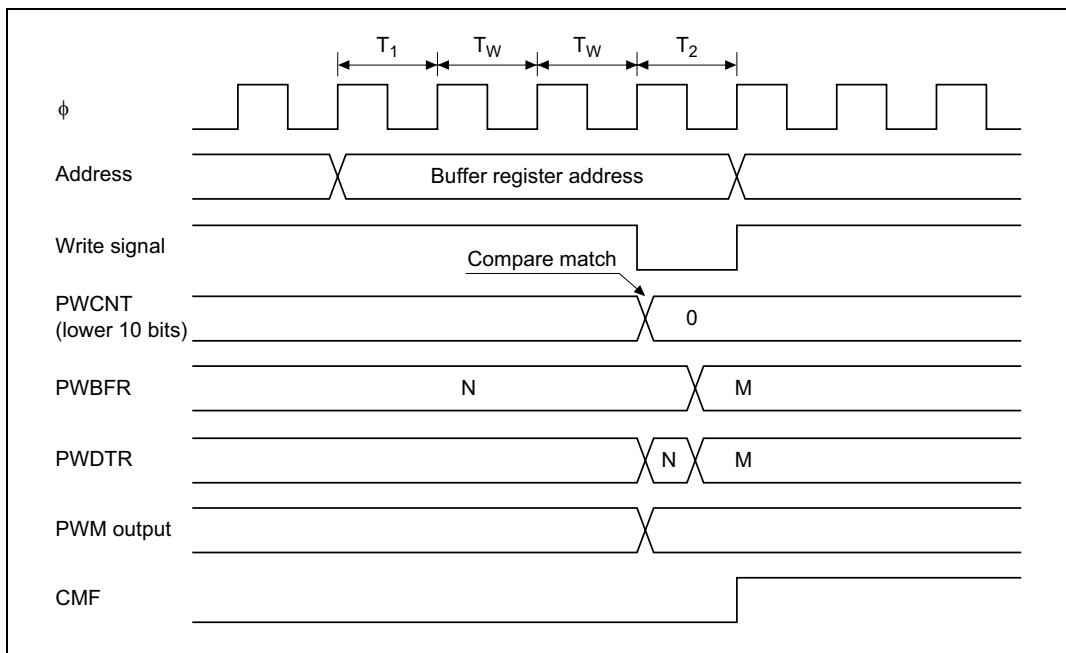

Figure 19-12 PWM Channel 1 Operation

Section 20 RAM

Note: The H8S/2635 Group is not equipped with a DTC.

20.1 Overview

The H8S/2636 has 4 kbytes, and H8S/2638, H8S/2639, and H8S/2630 have 16 kbytes of on-chip high-speed static RAM. The H8S/2635 has 6 kbytes of on-chip RAM. The RAM is connected to the CPU by a 16-bit data bus, enabling one-state access by the CPU to both byte data and word data. This makes it possible to perform fast word data transfer.

The on-chip RAM can be enabled or disabled by means of the RAM enable bit (RAME) in the system control register (SYSCR).

20.1.1 Block Diagram

Figure 20-1 shows a block diagram of the on-chip RAM.

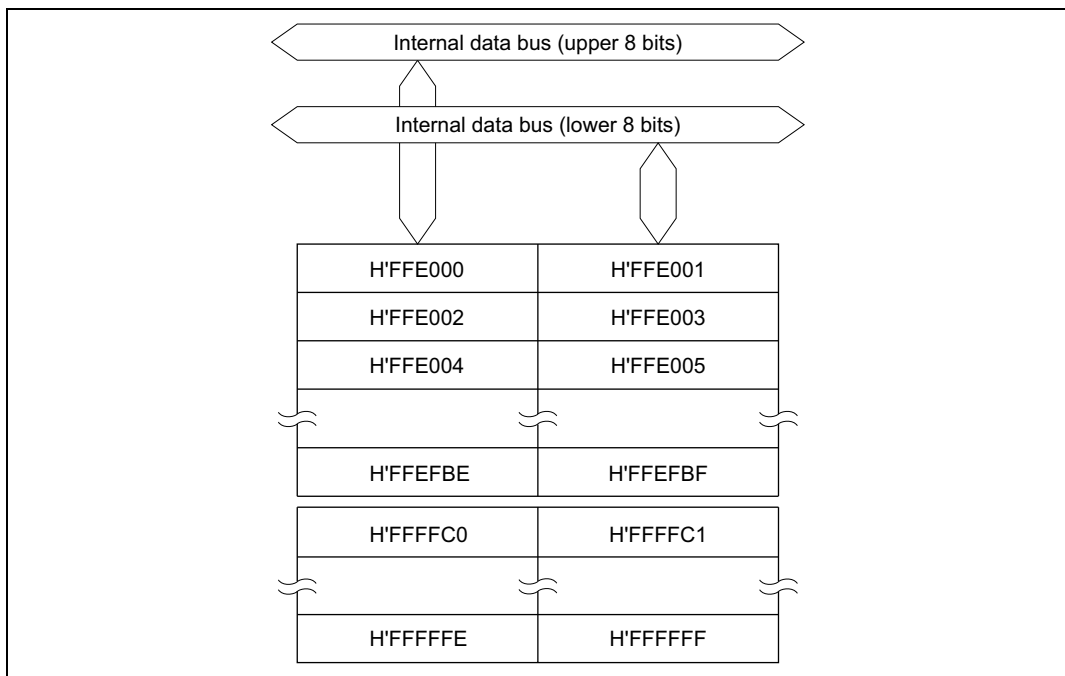

Figure 20-1 (a) Block Diagram of RAM (H8S/2636)

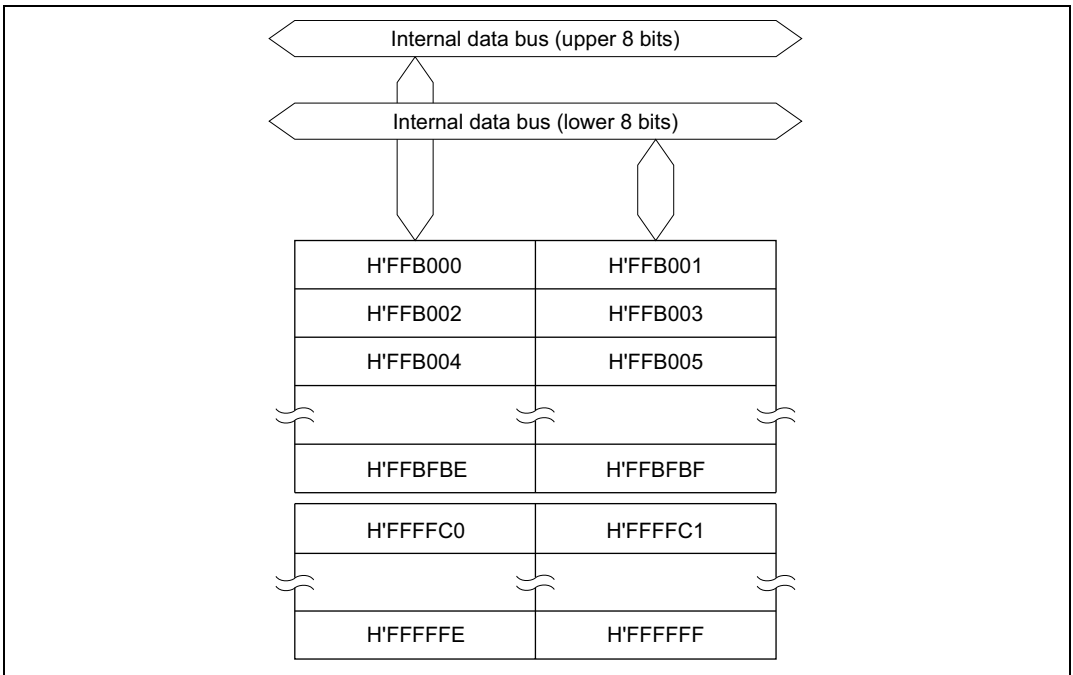

Figure 20-1 (b) Block Diagram of RAM (H8S/2638, H8S/2639, and H8S/2630)

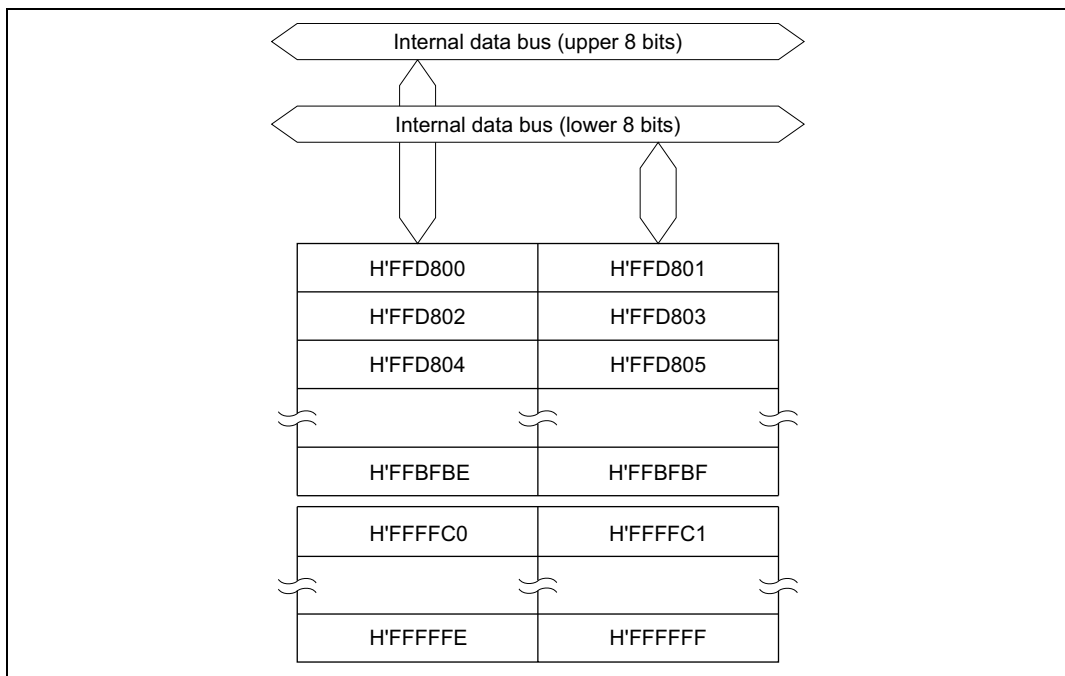

Figure 20-1 (c) Block Diagram of RAM (H8S/2635 Group)

20.1.2 Register Configuration

The on-chip RAM is controlled by SYSCR. Table 20-1 shows the address and initial value of SYSCR.

Table 20-1 RAM Register

Name	Abbreviation	R/W	Initial Value	Address*
System control register	SYSCR	R/W	H'01	H'FDE5

Note: * Lower 16 bits of the address.

20.2 Register Descriptions

20.2.1 System Control Register (SYSCR)

Bit	:	7	6	5	4	3	2	1	0
		MACS	—	INTM1	INTM0	NMIEG	—	—	RAME
Initial value :		0	0	0	0	0	0	0	1
R/W	:	R/W	—	R/W	R/W	R/W	R/W	—	R/W

The on-chip RAM is enabled or disabled by the RAME bit in SYSCR. For details of other bits in SYSCR, see section 3.2.2, System Control Register (SYSCR).

Bit 0—RAM Enable (RAME): Enables or disables the on-chip RAM. The RAME bit is initialized when the reset state is released. It is not initialized in software standby mode.

Bit 0

RAME	Description
0	On-chip RAM is disabled
1	On-chip RAM is enabled (Initial value)

20.3 Operation

When the RAME bit is set to 1, accesses to addresses H'FFE000 to H'FFEFBF (for the H8S/2636), H'FFB000 to H'FFEFBF (for the H8S/2638, H8S/2639, and H8S/2630), H'FFD800 to H'FFEFBF (for the H8S/2635 Group), or H'FFF0C0 to H'FFFFFF in the chip are directed to the on-chip RAM. When the RAME bit is cleared to 0, the off-chip address space is accessed.

Since the on-chip RAM is connected to the CPU by an internal 16-bit data bus, it can be written to and read in byte or word units. Each type of access can be performed in one state.

Even addresses use the upper 8 bits, and odd addresses use the lower 8 bits. Word data must start at an even address.

20.4 Usage Notes

When Using the DTC: DTC register information can be located in addresses H'FFEBC0 to H'FFEFBF. When the DTC is used, the RAME bit must not be cleared to 0.

Reserved Areas: Addresses H'FFB000 to H'FFDFFF in the H8S/2636 and H'FFB000 to H'FFD7FF in the H8S/2635 Group are reserved areas that cannot be read or written to. When the RAME bit is cleared to 0, the off-chip address space is accessed.

Section 21A ROM (H8S/2636 Group)

21A.1 Overview

The H8S/2636 has 128 kbytes of on-chip flash memory, or 128 kbytes of on-chip mask ROM. The ROM is connected to the bus master via a 16-bit data bus, enabling both byte and word data to be accessed in one state. Instruction fetching is thus speeded up, and processing speed increased.

The on-chip ROM is enabled and disabled by setting the mode pins (MD2 to MD0).

The flash memory version can be erased and programmed on-board, as well as with a special-purpose PROM programmer.

21A.1.1 Block Diagram

Figure 21A-1 shows a block diagram of 128-kbyte ROM.

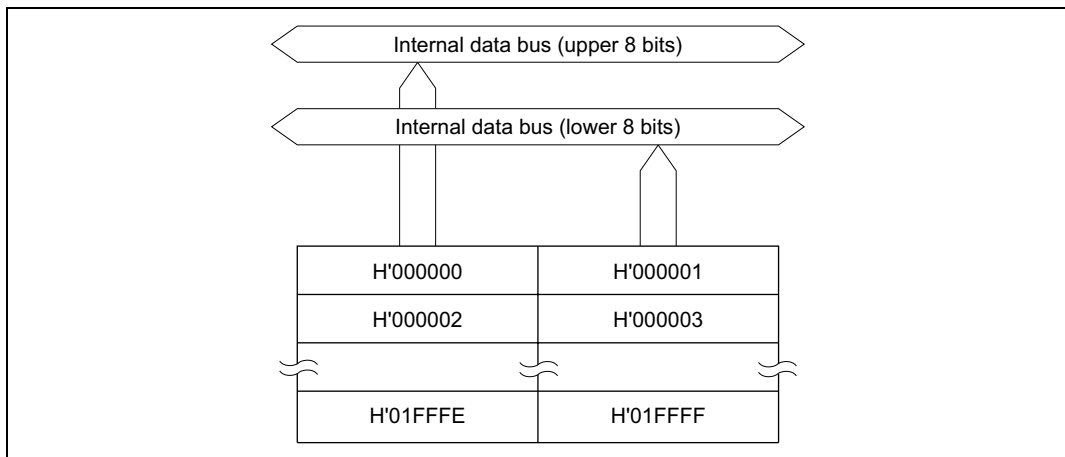

Figure 21A-1 Block Diagram of ROM (128 kbytes)

21A.1.2 Register Configuration

The H8S/2636 operating mode is controlled by the mode pins and the MDCR register. The register configuration is shown in table 21A-1.

Table 21A-1 Register Configuration

Register Name	Abbreviation	R/W	Initial Value	Address*
Mode control register	MDCR	R/W	Undefined	H'FDE7

Note: * Lower 16 bits of the address.

21A.2 Register Descriptions

21A.2.1 Mode Control Register (MDCR)

Bit:	7	6	5	4	3	2	1	0
	—	—	—	—	—	MDS2	MDS1	MDS0
Initial value:	1	0	0	0	0	—*	—*	—*
R/W:	R/W	—	—	—	—	R	R	R

Note: * Determined by pins MD2 to MD0.

MDCR is an 8-bit register used to monitor the current H8S/2636 Group operating mode.

Bit 7—Reserved: Only 1 should be written to these bits.

Bits 6 to 3—Reserved: These bits are always read as 0 and cannot be modified.

Bits 2 to 0—Mode Select 2 to 0 (MDS2 to MDS0): These bits indicate the input levels at pins MD2 to MD0 (the current operating mode). Bits MDS2 to MDS0 correspond to pins MD2 to MD0. MDS2 to MDS0 are read-only bits, and cannot be modified. The mode pin (MD2 to MD0) input levels are latched into these bits when MDCR is read. These latches are canceled by a reset.

21A.3 Operation

The on-chip ROM is connected to the CPU by a 16-bit data bus, and both byte and word data can be accessed in one state. Even addresses are connected to the upper 8 bits, and odd addresses to the lower 8 bits. Word data must start at an even address.

The on-chip ROM is enabled and disabled by setting the mode pins (MD2, MD1, and MD0). These settings are shown in table 21A-2.

Table 21A-2 Operating Modes and ROM (F-ZTAT Version)

Operating Mode		Mode Pins				On-Chip ROM
		FWE	MD2	MD1	MD0	
Mode 0	—	0	0	0	0	—
Mode 1					1	
Mode 2				1	0	
Mode 3					1	
Mode 4	Advanced expanded mode with on-chip ROM disabled	1	0	0	0	Disabled
Mode 5	Advanced expanded mode with on-chip ROM disabled				1	
Mode 6	Advanced expanded mode with on-chip ROM enabled			1	0	Enabled (128 kbytes)
Mode 7	Advanced single-chip mode				1	Enabled (128 kbytes)
Mode 8	—	1	0	0	0	—
Mode 9					1	
Mode 10	Boot mode (advanced expanded mode with on-chip ROM enabled)* ¹			1	0	Enabled (128 kbytes)
Mode 11	Boot mode (advanced single-chip mode)* ²				1	Enabled (128 kbytes)
Mode 12	—	1	0	0	0	—
Mode 13					1	
Mode 14	User program mode (advanced expanded mode with on-chip ROM enabled)* ¹			1	0	Enabled (128 kbytes)
Mode 15	User program mode (advanced single-chip mode)* ²				1	Enabled (128 kbytes)

Notes: 1. Apart from the fact that flash memory can be erased and programmed, operation is the same as in advanced expanded mode with on-chip ROM enabled.

2. Apart from the fact that flash memory can be erased and programmed, operation is the same as in advanced single-chip mode.

Table 21A-3 Operating Modes and ROM (Mask ROM Version)

Operating Mode		Mode Pins			On-Chip ROM
		MD2	MD1	MD0	
Mode 0	—	0	0	0	—
Mode 1				1	
Mode 2			1	0	
Mode 3				1	
Mode 4	Advanced expanded mode with on-chip ROM disabled	1	0	0	Disabled
Mode 5	Advanced expanded mode with on-chip ROM disabled			1	
Mode 6	Advanced expanded mode with on-chip ROM enabled		1	0	Enabled (128 kbytes)
Mode 7	Advanced single-chip mode			1	Enabled (128 kbytes)

21A.4 Flash Memory Overview

21A.4.1 Features

The H8S/2636 has 128 kbytes of on-chip flash memory, or 128 kbytes of on-chip mask ROM. The features of the flash memory are summarized below.

- Four flash memory operating modes
 - Program mode
 - Erase mode
 - Program-verify mode
 - Erase-verify mode
- Programming/erase methods

The flash memory is programmed 128 bytes at a time. Block erase (in single-block units) can be performed. To erase the entire flash memory, each block must be erased in turn. Blocks of 1 kbyte, 8 kbytes, 16 kbytes, 28 kbytes, and 32 kbytes can be erased as required.
- Programming/erase times

The flash memory programming time is 10 ms (typ.) for simultaneous 128-byte programming, equivalent to 80 μ s (typ.) per byte, and the erase time is 100 ms (typ.).
- Reprogramming capability

The flash memory can be reprogrammed up to 100 times.
- On-board programming modes

There are two modes in which flash memory can be programmed/erased/verified on-board:

 - Boot mode
 - User program mode
- Automatic bit rate adjustment

With data transfer in boot mode, the LSI's bit rate can be automatically adjusted to match the transfer bit rate of the host.
- Flash memory emulation in RAM

Flash memory programming can be emulated in real time by overlapping a part of RAM onto flash memory.
- Protect modes

There are two protect modes, hardware and software, which allow protected status to be designated for flash memory program/erase/verify operations.

- Programmer mode

Flash memory can be programmed/erased in programmer mode, using a PROM programmer, as well as in on-board programming mode.

21A.4.2 Block Diagram

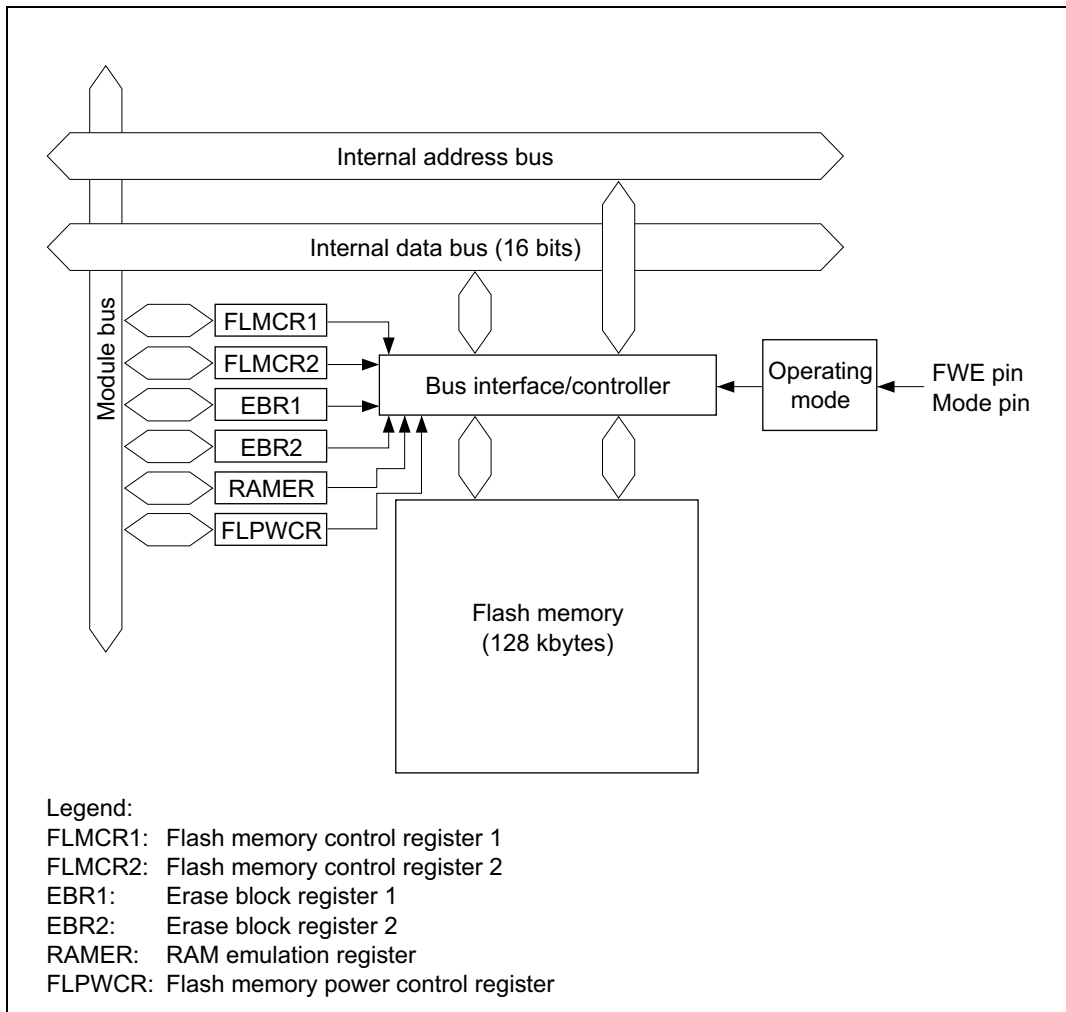

Figure 21A-2 Block Diagram of Flash Memory

21A.4.3 Mode Transitions

When the mode pins and the FWE pin are set in the reset state and a reset-start is executed, the microcomputer enters an operating mode as shown in figure 21A-3. In user mode, flash memory can be read but not programmed or erased.

The boot, user program and programmer modes are provided as modes to write and erase the flash memory.

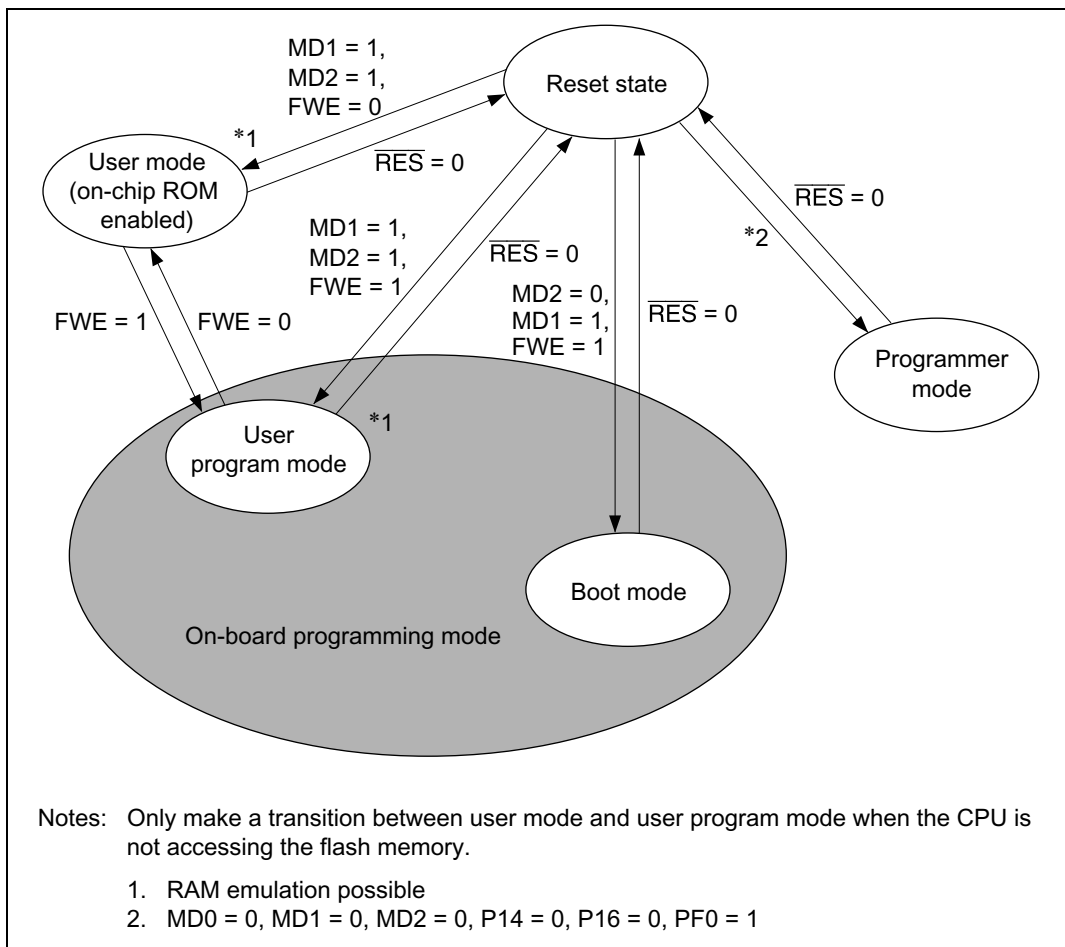

Figure 21A-3 Flash Memory State Transitions

21A.4.4 On-Board Programming Modes

Boot Mode

1. Initial state

The old program version or data remains written in the flash memory. The user should prepare the programming control program and new application program beforehand in the host.

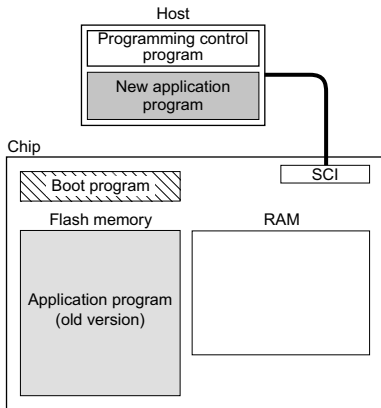

2. Programming control program transfer

When boot mode is entered, the boot program in the chip (originally incorporated in the chip) is started and the programming control program in the host is transferred to RAM via SCI communication. The boot program required for flash memory erasing is automatically transferred to the RAM boot program area.

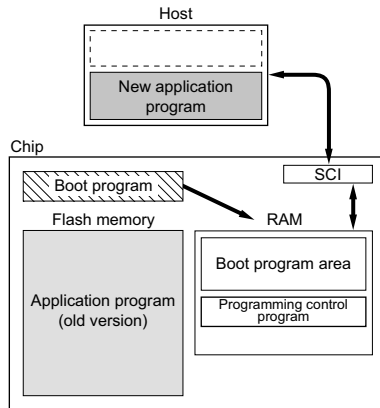

3. Flash memory initialization

The erase program in the boot program area (in RAM) is executed, and the flash memory is initialized (to H'FF). In boot mode, total flash memory erasure is performed, without regard to blocks.

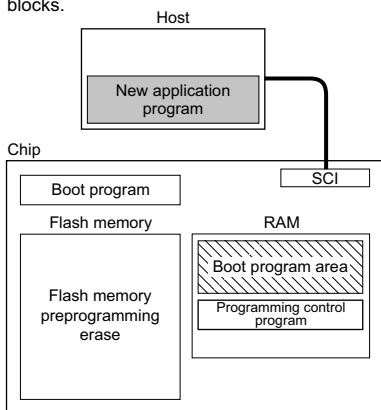

4. Writing new application program

The programming control program transferred from the host to RAM is executed, and the new application program in the host is written into the flash memory.

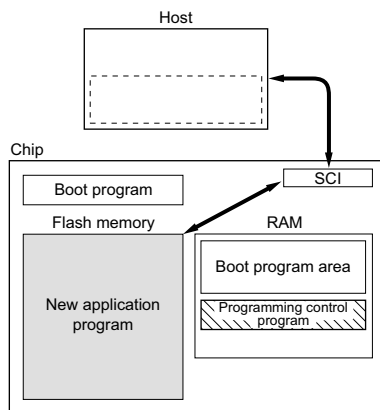

 Program execution state

User Program Mode

1. Initial state

The FWE assessment program that confirms that user program mode has been entered, and the program that will transfer the programming/erase control program from flash memory to on-chip RAM should be written into the flash memory by the user beforehand. The programming/erase control program should be prepared in the host or in the flash memory.

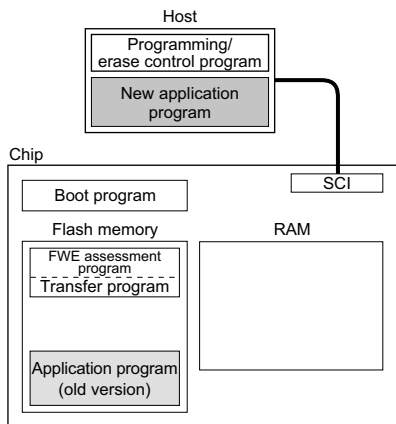

2. Programming/erase control program transfer
When user program mode is entered, user software confirms this fact, executes transfer program in the flash memory, and transfers the programming/erase control program to RAM.

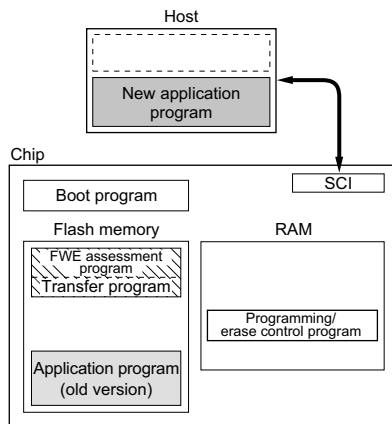

3. Flash memory initialization

The programming/erase program in RAM is executed, and the flash memory is initialized (to H'FF). Erasing can be performed in block units, but not in byte units.

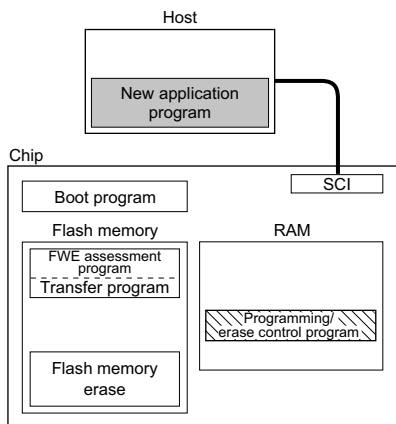

4. Writing new application program

Next, the new application program in the host is written into the erased flash memory blocks. Do not write to unerased blocks.

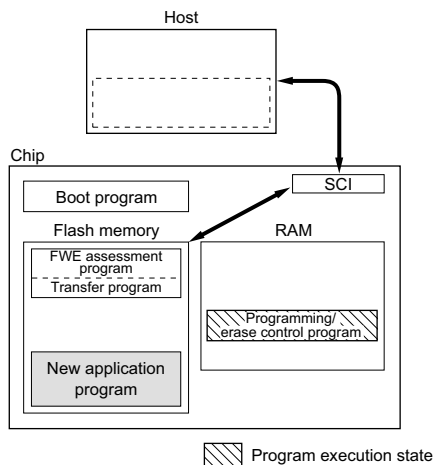

21A.4.5 Flash Memory Emulation in RAM

Emulation should be performed in user mode or user program mode. When the emulation block set in RAMER is accessed while the emulation function is being executed, data written in the overlap RAM is read.

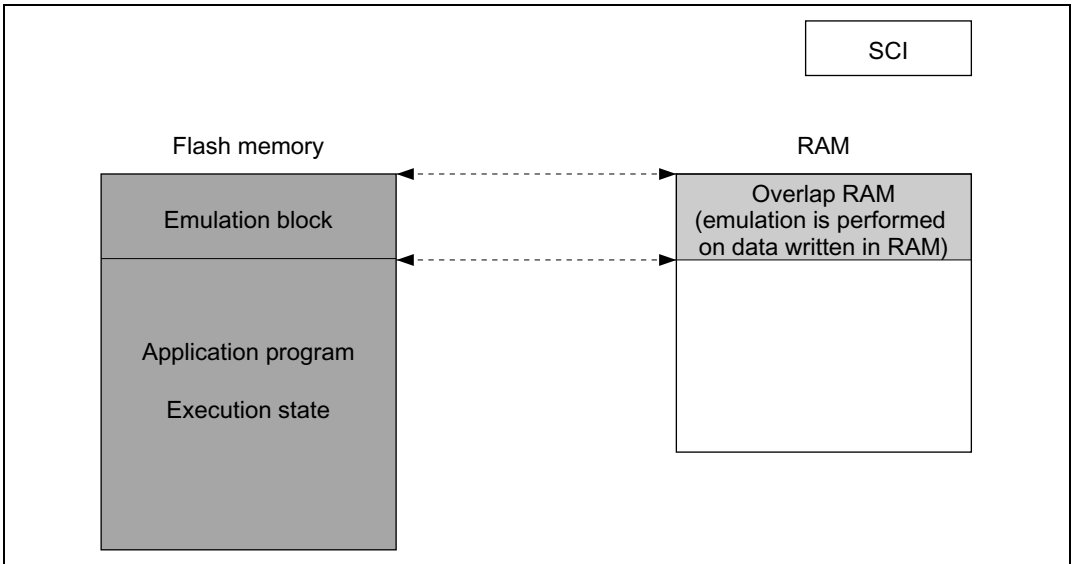

Figure 21A-4 Reading Overlap RAM Data in User Mode or User Program Mode

When overlap RAM data is confirmed, the RAMS bit is cleared, RAM overlap is released, and writes should actually be performed to the flash memory.

When the programming control program is transferred to RAM, ensure that the transfer destination and the overlap RAM do not overlap, as this will cause data in the overlap RAM to be rewritten.

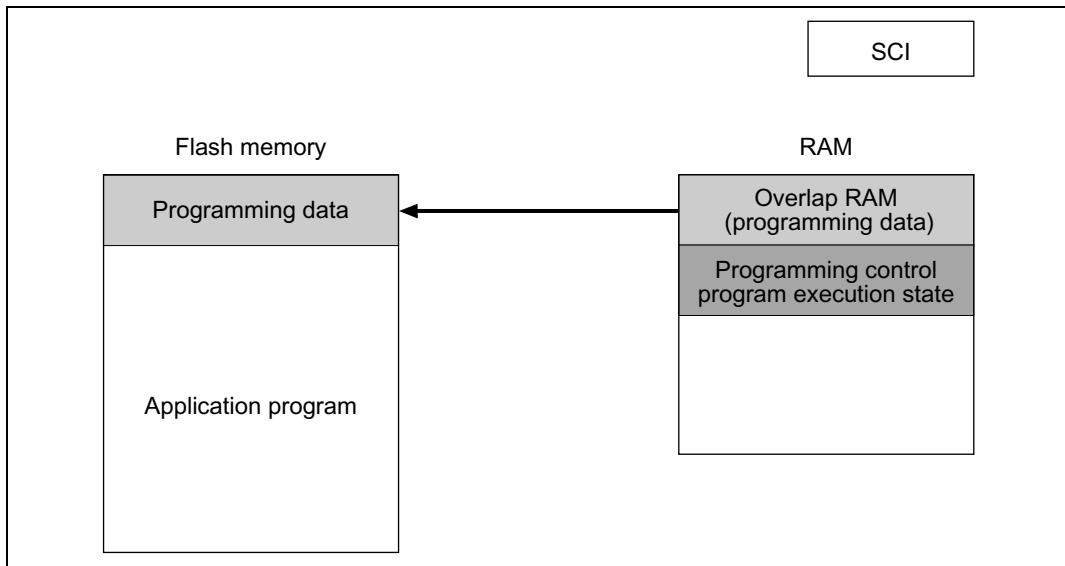

Figure 21A-5 Writing Overlap RAM Data in User Program Mode

21A.4.6 Differences between Boot Mode and User Program Mode

Table 21A-4 Differences between Boot Mode and User Program Mode

	Boot Mode	User Program Mode
Total erase	Yes	Yes
Block erase	No	Yes
Programming control program*	(2)	(1) (2) (3)

(1) Erase/erase-verify

(2) Program/program-verify

(3) Emulation

Note: * To be provided by the user, in accordance with the recommended algorithm.

21A.4.7 Block Configuration

The flash memory is divided into two 32 kbytes blocks, one 28 kbytes block, one 16 kbytes block, two 8 kbytes blocks, and four 1 kbyte blocks.

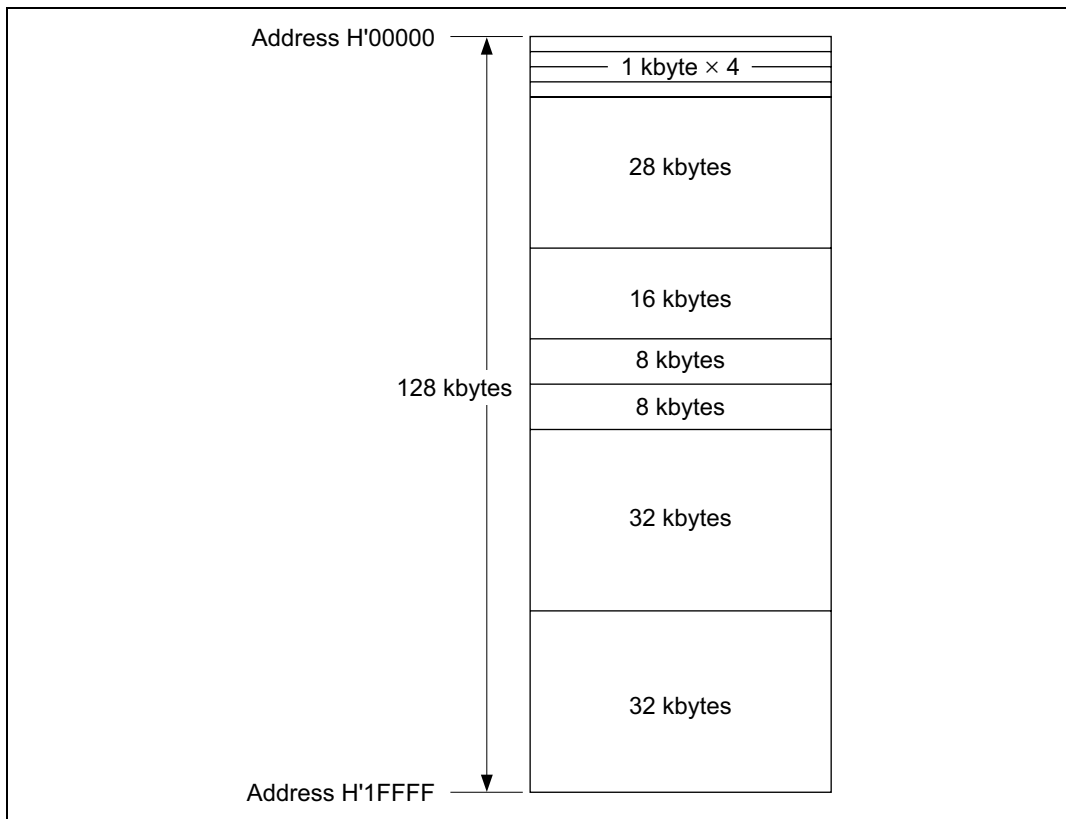

Figure 21A-6 Block Configuration

21A.5 Pin Configuration

The flash memory is controlled by means of the pins shown in table 21A-5.

Table 21A-5 Pin Configuration

Pin Name	Abbreviation	I/O	Function
Reset	$\overline{\text{RES}}$	Input	Reset
Flash write enable	FWE	Input	Flash program/erase protection by hardware
Mode 2	MD2	Input	Sets LSI operating mode
Mode 1	MD1	Input	Sets LSI operating mode
Mode 0	MD0	Input	Sets LSI operating mode
Port F0	PF0	Input	Sets LSI operating mode when MD2 = MD1 = MD0 = 0
Port 16	P16	Input	Sets LSI operating mode when MD2 = MD1 = MD0 = 0
Port 14	P14	Input	Sets LSI operating mode when MD2 = MD1 = MD0 = 0
Transmit data	TxD1	Output	Serial transmit data output
Receive data	RxD1	Input	Serial receive data input

21A.6 Register Configuration

The registers used to control the on-chip flash memory when enabled are shown in table 21A-6.

Table 21A-6 Register Configuration

Register Name	Abbreviation	R/W	Initial Value	Address ^{*1}
Flash memory control register 1	FLMCR1 ^{*4}	R/W	H'00 ^{*2}	H'FFA8
Flash memory control register 2	FLMCR2 ^{*4}	R	H'00	H'FFA9
Erase block register 1	EBR1 ^{*4}	R/W	H'00 ^{*3}	H'FFAA
Erase block register 2	EBR2 ^{*4}	R/W	H'00 ^{*3}	H'FFAB
RAM emulation register	RAMER ^{*4}	R/W	H'00	H'FEDB
Flash memory power control register	FLPWCR ^{*4}	R/W	H'00 ^{*3}	H'FFAC

Notes: 1. Lower 16 bits of the address.

2. When a high level is input to the FWE pin, the initial value is H'80.

3. When a low level is input to the FWE pin, or if a high level is input and the SWE1 bit in FLMCR1 is not set, these registers are initialized to H'00.

4. FLMCR1, FLMCR2, EBR1, and EBR2, RAMER, and FLPWCR are 8-bit registers.

Use byte access on these registers.

21A.7 Register Descriptions

21A.7.1 Flash Memory Control Register 1 (FLMCR1)

FLMCR1 is an 8-bit register used for flash memory operating mode control. Program-verify mode or erase-verify mode for on-chip flash memory is entered by setting SWE bit to 1 when FWE = 1, then setting the PV or EV bit. Program mode for on-chip flash memory is entered by setting SWE bit to 1 when FWE = 1, then setting the PSU bit, and finally setting the P bit. Erase mode for on-chip flash memory is entered by setting SWE bit to 1 when FWE = 1, then setting the ESU bit, and finally setting the E bit. FLMCR1 is initialized by a reset, and in hardware standby mode and software standby mode. Its initial value is H'80 when a high level is input to the FWE pin, and H'00 when a low level is input. When on-chip flash memory is disabled, a read will return H'00, and writes are invalid.

Writes are enabled only in the following cases: Writes to bit SWE of FLMCR1 enabled when FWE = 1, to bits ESU, PSU, EV, and PV when FWE = 1 and SWE = 1, to bit E when FWE = 1, SWE = 1 and ESU = 1, and to bit P when FWE = 1, SWE = 1, and PSU = 1.

Bit:	7	6	5	4	3	2	1	0
	FWE	SWE	ESU	PSU	EV	PV	E	P
Initial value:	—*	0	0	0	0	0	0	0
R/W:	R	R/W	R/W	R/W	R/W	R/W	R/W	R/W

Note: * Determined by the state of the FWE pin.

Bit 7—Flash Write Enable Bit (FWE): Sets hardware protection against flash memory programming/erasing.

Bit 7: FWE Description

0	When a low level is input to the FWE pin (hardware-protected state)
1	When a high level is input to the FWE pin

Bit 6—Software Write Enable Bit (SWE): Enables or disables flash memory programming and erasing. Set this bit when setting bits 5 to 0, bits 7 to 0 of EBR1, and bits 1 and 0 of EBR2.

Bit 6: SWE	Description
0	Writes disabled (Initial value)
1	Writes enabled [Setting condition] <ul style="list-style-type: none"> When FWE = 1

Bit 5—Erase Setup Bit (ESU): Prepares for a transition to erase mode. Set this bit to 1 before setting the E bit in FLMCR1 to 1. Do not set the SWE, PSU, EV, PV, E, or P bit at the same time.

Bit 5: ESU	Description
0	Erase setup cleared (Initial value)
1	Erase setup [Setting condition] <ul style="list-style-type: none"> When FWE = 1 and SWE = 1

Bit 4—Program Setup Bit (PSU): Prepares for a transition to program mode. Set this bit to 1 before setting the P bit in FLMCR1 to 1. Do not set the SWE, ESU, EV, PV, E, or P bit at the same time.

Bit 4: PSU	Description
0	Program setup cleared (Initial value)
1	Program setup [Setting condition] <ul style="list-style-type: none"> When FWE = 1 and SWE = 1

Bit 3—Erase-Verify (EV): Selects erase-verify mode transition or clearing. Do not set the SWE, ESU, PSU, PV, E, or P bit at the same time.

Bit 3: EV	Description
0	Erase-verify mode cleared (Initial value)
1	Transition to erase-verify mode [Setting condition] <ul style="list-style-type: none"> When FWE = 1 and SWE = 1

Bit 2—Program-Verify (PV): Selects program-verify mode transition or clearing. Do not set the SWE, ESU, PSU, EV, E, or P bit at the same time.

Bit 2: PV Description

0	Program-verify mode cleared	(Initial value)
1	Transition to program-verify mode [Setting condition]	
	<ul style="list-style-type: none"> When FWE = 1 and SWE = 1 	

Bit 1—Erase (E): Selects erase mode transition or clearing. Do not set the SWE, ESU, PSU, EV, PV, or P bit at the same time.

Bit 1: E Description

0	Erase mode cleared	(Initial value)
1	Transition to erase mode [Setting condition]	
	<ul style="list-style-type: none"> When FWE = 1, SWE = 1, and ESU = 1 	

Bit 0—Program (P): Selects program mode transition or clearing. Do not set the SWE, PSU, ESU, EV, PV, or E bit at the same time.

Bit 0: P Description

0	Program mode cleared	(Initial value)
1	Transition to program mode [Setting condition]	
	<ul style="list-style-type: none"> When FWE = 1, SWE = 1, and PSU = 1 	

21A.7.2 Flash Memory Control Register 2 (FLMCR2)

FLMCR2 is an 8-bit register used for flash memory operating mode control. FLMCR2 is initialized to H'00 by a reset, and in hardware standby mode and software standby mode. When on-chip flash memory is disabled, a read will return H'00.

Bit:	7	6	5	4	3	2	1	0
	FLER	—	—	—	—	—	—	—
Initial value:	0	0	0	0	0	0	0	0
R/W:	R	—	—	—	—	—	—	—

Note: FLMCR2 is a read-only register, and should not be written to.

Bit 7—Flash Memory Error (FLER): Indicates that an error has occurred during an operation on flash memory (programming or erasing). When FLER is set to 1, flash memory goes to the error-protection state.

Bit 7: FLER	Description
0	Flash memory is operating normally (Initial value) Flash memory program/erase protection (error protection) is disabled [Clearing condition] <ul style="list-style-type: none"> Reset or hardware standby mode
1	An error has occurred during flash memory programming/erasing Flash memory program/erase protection (error protection) is enabled [Setting condition] <ul style="list-style-type: none"> See section 21A.10.3, Error Protection

Bits 6 to 0—Reserved: These bits always read 0.

21A.7.3 Erase Block Register 1 (EBR1)

EBR1 is an 8-bit register that specifies the flash memory erase area block by block. EBR1 is initialized to H'00 by a reset, in hardware standby mode and software standby mode, when a low level is input to the FWE pin, and when a high level is input to the FWE pin and the SWE bit in FLMCR1 is not set. When a bit in EBR1 is set to 1, the corresponding block can be erased. Other blocks are erase-protected. Only one of the bits of EBR1 and EBR2 combined can be set. Do not set more than one bit, as this will cause all the bits in both EBR1 and EBR2 to be automatically cleared to 0. When on-chip flash memory is disabled, a read will return H'00, and writes are invalid.

The flash memory block configuration is shown in table 21A-6.

Bit:	7	6	5	4	3	2	1	0
	EB7	EB6	EB5	EB4	EB3	EB2	EB1	EB0
Initial value:	0	0	0	0	0	0	0	0
R/W:	R/W	R/W	R/W	R/W	R/W	R/W	R/W	R/W

21A.7.4 Erase Block Register 2 (EBR2)

EBR2 is an 8-bit register that specifies the flash memory erase area block by block. EBR2 is initialized to H'00 by a reset, in hardware standby mode and software standby mode, when a low level is input to the FWE pin. Bit 0 will be initialized to 0 if bit SWE of FLMCR1 is not set, even though a high level is input to pin FWE. When a bit in EBR2 is set to 1, the corresponding block can be erased. Other blocks are erase-protected. Only one of the bits of EBR1 and EBR2 combined can be set. Do not set more than one bit, as this will cause all the bits in both EBR1 and EBR2 to be automatically cleared to 0. Bits 7 to 2 are reserved and must only be written with 0. When on-chip flash memory is disabled, a read will return H'00, and writes are invalid.

The flash memory block configuration is shown in table 21A-7.

Bit:	7	6	5	4	3	2	1	0
	—	—	—	—	—	—	EB9	EB8
Initial value:	0	0	0	0	0	0	0	0
R/W:	R/W	R/W	R/W	R/W	R/W	R/W	R/W	R/W

Table 21A-7 Flash Memory Erase Blocks (H8S/2636)

Block (Size)	Addresses
EB0 (1 kbyte)	H'000000 to H'0003FF
EB1 (1 kbyte)	H'000400 to H'0007FF
EB2 (1 kbyte)	H'000800 to H'000BFF
EB3 (1 kbyte)	H'000C00 to H'000FFF
EB4 (28 kbytes)	H'001000 to H'007FFF
EB5 (16 kbytes)	H'008000 to H'00BFFF
EB6 (8 kbytes)	H'00C000 to H'00DFFF
EB7 (8 kbytes)	H'00E000 to H'00FFFF
EB8 (32 kbytes)	H'010000 to H'017FFF
EB9 (32 kbytes)	H'018000 to H'01FFFF

21A.7.5 RAM Emulation Register (RAMER)

RAMER specifies the area of flash memory to be overlapped with part of RAM when emulating real-time flash memory programming. RAMER initialized to H'00 by a reset and in hardware standby mode. It is not initialized by software standby mode. RAMER settings should be made in user mode or user program mode.

Flash memory area divisions are shown in table 21A-8. To ensure correct operation of the emulation function, the ROM for which RAM emulation is performed should not be accessed immediately after this register has been modified. Normal execution of an access immediately after register modification is not guaranteed.

Bit:	7	6	5	4	3	2	1	0
	—	—	—	—	RAMS	RAM2	RAM1	RAM0
Initial value:	0	0	0	0	0	0	0	0
R/W:	R	R	R/W	R/W	R/W	R/W	R/W	R/W

Bits 7 and 6—Reserved: These bits always read 0.

Bits 5 and 4—Reserved: Only 0 may be written to these bits.

Bit 3—RAM Select (RAMS): Specifies selection or non-selection of flash memory emulation in RAM. When RAMS = 1, all flash memory block are program/erase-protected.

Bit 3: RAMS	Description
0	Emulation not selected Program/erase-protection of all flash memory blocks is disabled (Initial value)
1	Emulation selected Program/erase-protection of all flash memory blocks is enabled

Bits 2, 1 and 0—Flash Memory Area Selection: These bits are used together with bit 3 to select the flash memory area to be overlapped with RAM (See table 21A-7).

Table 21A-8 Flash Memory Area Divisions (H8S/2636)

Addresses	Block Name	RAMS	RAM2	RAM1	RAM0
H'FFE000 to H'FFE3FF	RAM area 1 kbyte	0	*	*	*
H'000000 to H'0003FF	EB0 (1 kbyte)	1	0	0	*
H'000400 to H'0007FF	EB1 (1 kbyte)	1	0	1	*
H'000800 to H'000BFF	EB2 (1 kbyte)	1	1	0	*
H'000C00 to H'000FFF	EB3 (1 kbyte)	1	1	1	*

*: Don't care

21A.7.6 Flash Memory Power Control Register (FLPWCR)

Bit:	7	6	5	4	3	2	1	0
	PDWND	—	—	—	—	—	—	—
Initial value:	0	0	0	0	0	0	0	0
R/W:	R/W	R	R	R	R	R	R	R

FLPWCR enables or disables a transition to the flash memory power-down mode when the LSI switches to subactive mode*.

Note: * Subclock functions (subactive mode, subsleep mode, and watch mode) are available in the U-mask version only.

These functions cannot be used with the other versions.

Bit 7—Power-Down Disable (PDWND): Enables or disables a transition to the flash memory power-down mode when the LSI switches to subactive mode. For details, see section 21A.14, Flash Memory and Power-Down States.

The subactive mode can be used in the U-mask version only.

When writing to this bit in other versions, be sure to write 0.

Bit 7: PDWND	Description	
0	Transition to flash memory power-down mode enabled	(Initial value)
1	Transition to flash memory power-down mode disabled	

Bits 6 to 0—Reserved: These bits always read 0.

21A.8 On-Board Programming Modes

When pins are set to on-board programming mode and a reset-start is executed, a transition is made to the on-board programming state in which program/erase/verify operations can be performed on the on-chip flash memory. There are two on-board programming modes: boot mode and user program mode. The pin settings for transition to each of these modes are shown in table 21A-9. For a diagram of the transitions to the various flash memory modes, see figure 21A-3.

Table 21A-9 Setting On-Board Programming Modes

Mode		FWE	MD2	MD1	MD0
Boot mode	Expanded mode	1	0	1	0
	Single-chip mode		0	1	1
User program mode	Expanded mode	1	1	1	0
	Single-chip mode		1	1	1

21A.8.1 Boot Mode

When boot mode is used, the flash memory programming control program must be prepared in the host beforehand. The SCI channel to be used is set to asynchronous mode.

When a reset-start is executed after the LSI's pins have been set to boot mode, the boot program built into the LSI is started and the programming control program prepared in the host is serially transmitted to the LSI via the SCI. In the LSI, the programming control program received via the SCI is written into the programming control program area in on-chip RAM. After the transfer is completed, control branches to the start address of the programming control program area and the programming control program execution state is entered (flash memory programming is performed).

The transferred programming control program must therefore include coding that follows the programming algorithm given later.

The system configuration in boot mode is shown in figure 21A-7, and the boot mode execution procedure in figure 21A-8.

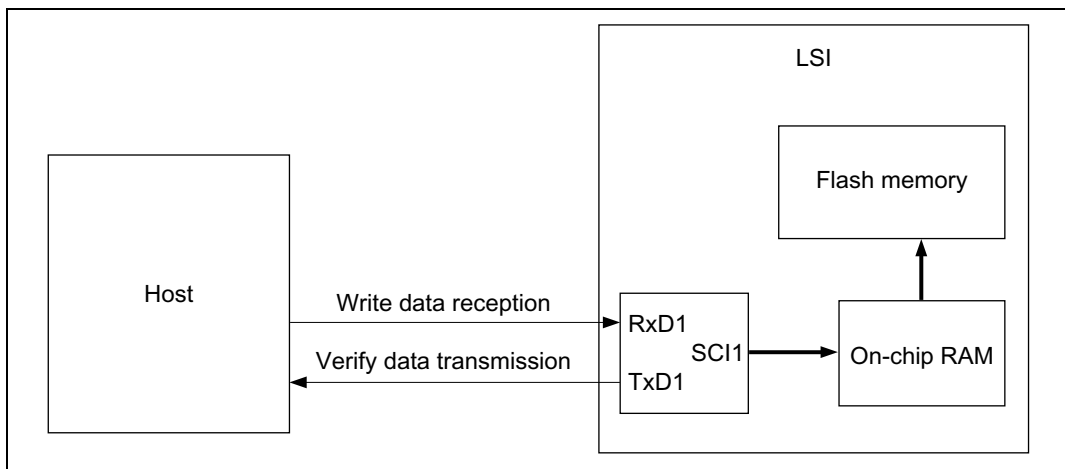

Figure 21A-7 System Configuration in Boot Mode

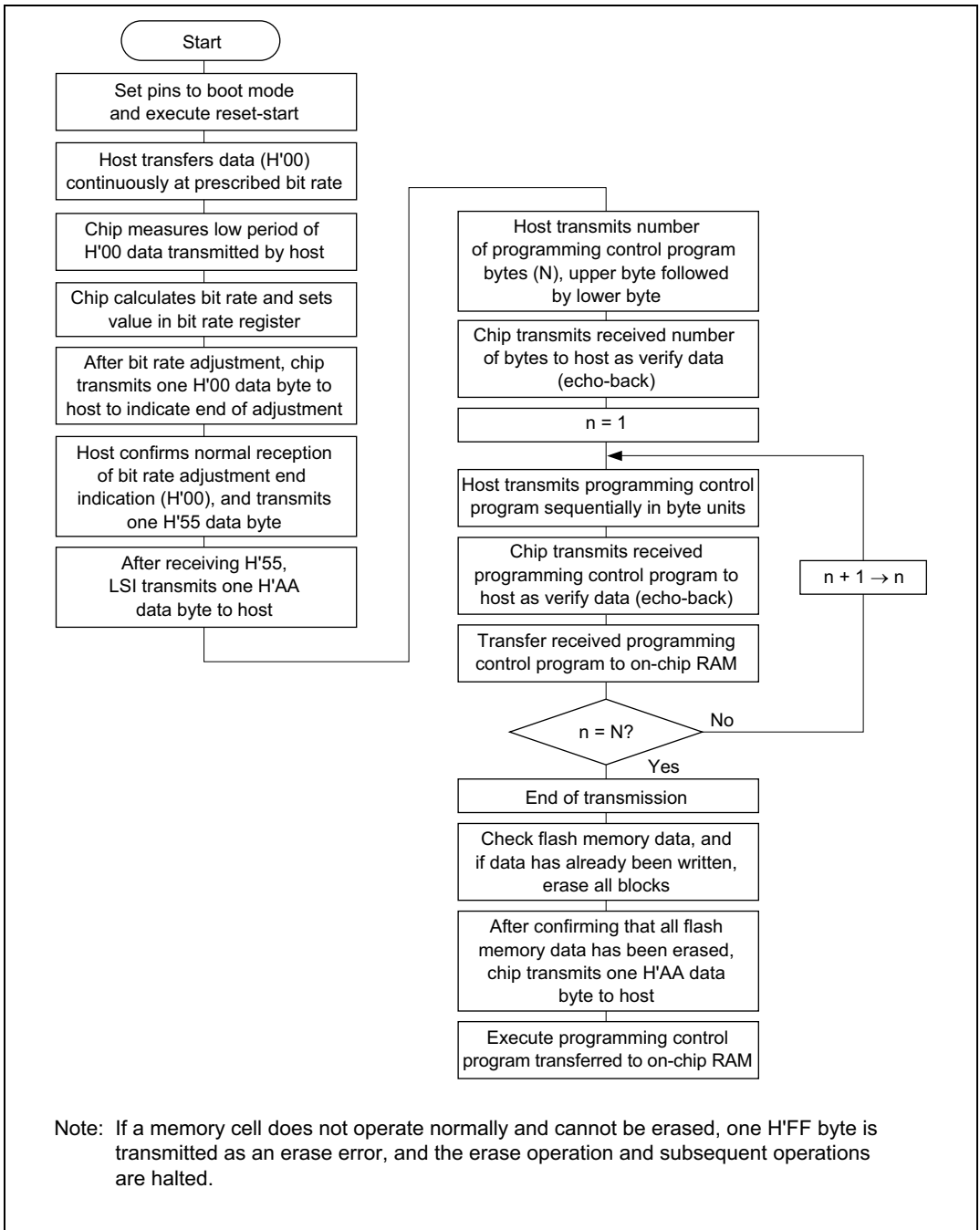
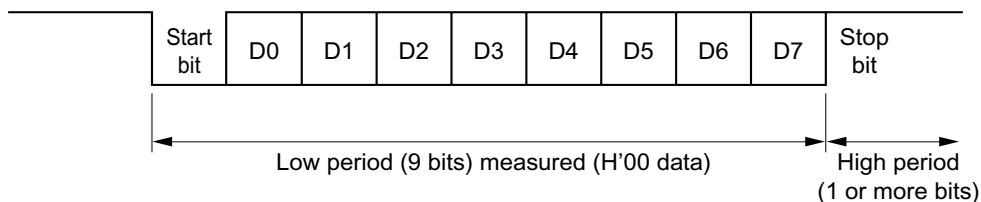

Figure 21A-8 Boot Mode Execution Procedure

Automatic SCI Bit Rate Adjustment



When boot mode is initiated, the LSI measures the low period of the asynchronous SCI communication data (H'00) transmitted continuously from the host. The SCI transmit/receive format should be set as follows: 8-bit data, 1 stop bit, no parity. The LSI calculates the bit rate of the transmission from the host from the measured low period, and transmits one H'00 byte to the host to indicate the end of bit rate adjustment. The host should confirm that this adjustment end indication (H'00) has been received normally, and transmit one H'55 byte to the LSI. If reception cannot be performed normally, initiate boot mode again (reset), and repeat the above operations. Depending on the host's transmission bit rate and the LSI's system clock frequency, there will be a discrepancy between the bit rates of the host and the LSI. Set the host transfer bit rate at 4,800, 9,600 or 19,200 bps to operate the SCI properly.

Table 21A-10 shows host transfer bit rates and system clock frequencies for which automatic adjustment of the LSI bit rate is possible. The boot program should be executed within this system clock range.

Table 21A-10 System Clock Frequencies for which Automatic Adjustment of LSI Bit Rate Is Possible

Host Bit Rate	System Clock Frequency for which Automatic Adjustment of LSI Bit Rate Is Possible
4,800 bps	4 to 20 MHz
9,600 bps	8 to 20 MHz
19,200 bps	16 to 20 MHz

Note: The system clock frequency used in boot mode is generated by an external crystal oscillator element. PLL frequency multiplication is not used.

On-Chip RAM Area Divisions in Boot Mode: In boot mode, the RAM area is divided into an area used by the boot program and an area to which the programming control program is transferred via the SCI, as shown in figure 21A-9. The boot program area cannot be used until the execution state in boot mode switches to the programming control program transferred from the host.

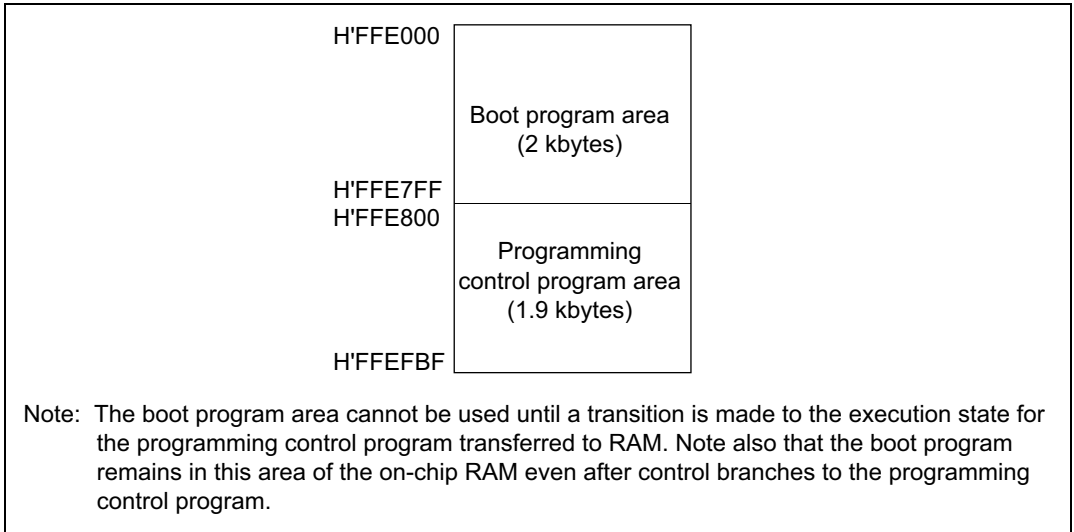

Figure 21A-9 RAM Areas in Boot Mode

Notes on Use of Boot Mode:

- When the chip comes out of reset in boot mode, it measures the low-level period of the input at the SCI's RxD1 pin. The reset should end with RxD1 high. After the reset ends, it takes approximately 100 states before the chip is ready to measure the low-level period of the RxD1 pin.
- In boot mode, if any data has been programmed into the flash memory (if all data is not 1), all flash memory blocks are erased. Boot mode is for use when user program mode is unavailable, such as the first time on-board programming is performed, or if the program activated in user program mode is accidentally erased.
- Interrupts cannot be used while the flash memory is being programmed or erased.
- The RxD1 and TxD1 pins should be pulled up on the board.

- Before branching to the programming control program (RAM area H'FFE800), the chip terminates transmit and receive operations by the on-chip SCI (channel 1) (by clearing the RE and TE bits in SCR to 0), but the adjusted bit rate value remains set in BRR. The transmit data output pin, TxD1, goes to the high-level output state (P33DDR = 1, P33DR = 1).

The contents of the CPU's internal general registers are undefined at this time, so these registers must be initialized immediately after branching to the programming control program. In particular, since the stack pointer (SP) is used implicitly in subroutine calls, etc., a stack area must be specified for use by the programming control program.

The initial values of other on-chip registers are not changed.

- Boot mode can be entered by making the pin settings shown in table 21A-9 and executing a reset-start.

Boot mode can be cleared by driving the reset pin low, waiting at least 20 states, then setting the FWE pin and mode pins, and executing reset release*¹. Boot mode can also be cleared by a WDT overflow reset.

Do not change the mode pin input levels in boot mode, and do not drive the FWE pin low*³ while the boot program is being executed or while flash memory is being programmed or erased.

- If the mode pin input levels are changed (for example, from low to high) during a reset, the state of ports with multiplexed address functions and bus control output pins (\overline{AS} , \overline{RD} , \overline{HWR}) will change according to the change in the microcomputer's operating mode*².

Therefore, care must be taken to make pin settings to prevent these pins from becoming output signal pins during a reset, or to prevent collision with signals outside the microcomputer.

- Notes:
1. Mode pin and FWE pin input must satisfy the mode programming setup time ($t_{MDS} = 4$ states) with respect to the reset release timing.
 2. See Appendix D, Pin States.
 3. For precautions on applying and disconnecting FWE, see section 21A.15, Flash Memory Programming and Erasing Precautions.

21A.8.2 User Program Mode

When set to user program mode, the chip can program and erase its flash memory by executing a user program/erase control program. Therefore, on-board reprogramming of the on-chip flash memory can be carried out by providing on-board means of FWE control and supply of programming data, and storing a program/erase control program in part of the program area as necessary.

To select user program mode, select a mode that enables the on-chip flash memory (mode 6 or 7), and apply a high level to the FWE pin. In this mode, on-chip supporting modules other than flash memory operate as they normally would in modes 6 and 7.

The flash memory itself cannot be read while the SWE bit is set to 1 to perform programming or erasing, so the control program that performs programming and erasing should be run in on-chip RAM or external memory. If the program is to be located in external memory, the instruction for writing to flash memory, and the following instruction, should be placed in on-chip RAM.

Figure 21A-10 shows the procedure for executing the program/erase control program when transferred to on-chip RAM.

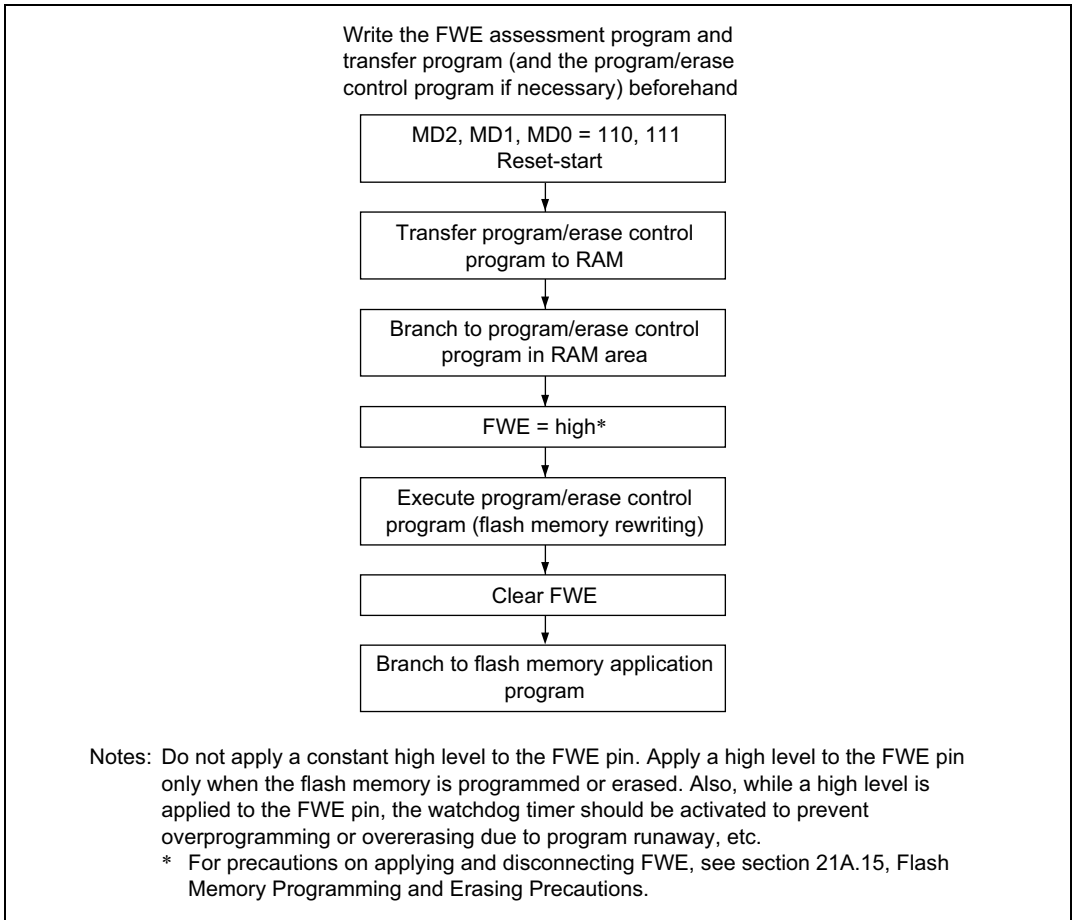

Figure 21A-10 User Program Mode Execution Procedure

21A.9 Flash Memory Programming/Erasing

A software method, using the CPU, is employed to program and erase flash memory in the on-board programming modes. There are four flash memory operating modes: program mode, erase mode, program-verify mode, and erase-verify mode. Transitions to these modes for on-chip flash memory are made by setting the PSU, ESU, P, E, PV, and EV bits in FLMCR1.

The flash memory cannot be read while being programmed or erased. Therefore, the program (user program) that controls flash memory programming/erasing should be located and executed in on-chip RAM or external memory. If the program is to be located in external memory, the instruction for writing to flash memory, and the following instruction, should be placed in on-chip RAM. Also ensure that the DTC is not activated before or after execution of the flash memory write instruction.

In the following operation descriptions, wait times after setting or clearing individual bits in FLMCR1 are given as parameters; for details of the wait times, see section 24.1.7, Flash Memory Characteristics.

- Notes:
1. Operation is not guaranteed if setting/resetting of the SWE, ESU, PSU, EV, PV, E, and P bits in FLMCR1 is executed by a program in flash memory.
 2. When programming or erasing, set FWE to 1 (programming/erasing will not be executed if FWE = 0).
 3. Programming must be executed in the erased state. Do not perform additional programming on addresses that have already been programmed.

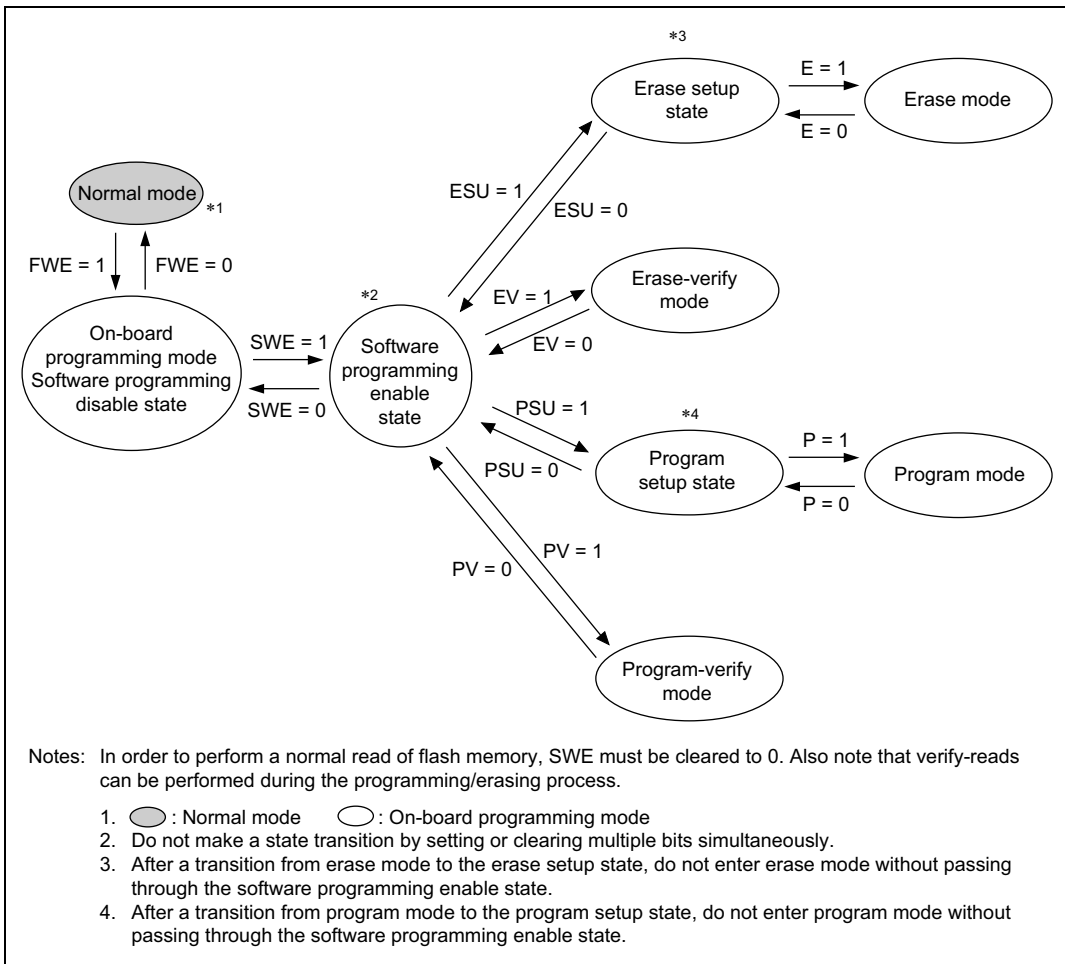

Figure 21A-11 FLMCR1 Bit Settings and State Transitions

21A.9.1 Program Mode

When writing data or programs to flash memory, the program/program-verify flowchart shown in figure 21A-12 should be followed. Performing programming operations according to this flowchart will enable data or programs to be written to flash memory without subjecting the device to voltage stress or sacrificing program data reliability. Programming should be carried out 128 bytes at a time.

The wait times after bits are set or cleared in the flash memory control register 1 (FLMCR1) and the maximum number of programming operations (N) are shown in table 24-10 in section 24.1.7, Flash Memory Characteristics.

Following the elapse of (t_{sswe}) μ s or more after the SWE bit is set to 1 in FLMCR1, 128-byte data is written consecutively to the write addresses. The lower 8 bits of the first address written to must be H'00 and H'80, 128 consecutive byte data transfers are performed. The program address and program data are latched in the flash memory. A 128-byte data transfer must be performed even if writing fewer than 128 bytes; in this case, H'FF data must be written to the extra addresses.

Next, the watchdog timer (WDT) is set to prevent overprogramming due to program runaway, etc. Set a value greater than ($t_{spsu} + t_{sp} + t_{cp} + t_{cpsu}$) μ s as the WDT overflow period. Preparation for entering program mode (program setup) is performed next by setting the PSU bit in FLMCR1. The operating mode is then switched to program mode by setting the P bit in FLMCR1 after the elapse of at least (t_{spsu}) μ s. The time during which the P bit is set is the flash memory programming time. Make a program setting so that the time for one programming operation is within the range of (t_{sp}) μ s.

The wait time after P bit setting must be changed according to the degree of progress through the programming operation. For details see "Notes on Program/Program-Verify Procedure."

21A.9.2 Program-Verify Mode

In program-verify mode, the data written in program mode is read to check whether it has been correctly written in the flash memory.

After the elapse of the given programming time, clear the P bit in FLMCR1, then wait for at least (t_{cp}) μ s before clearing the PSU bit to exit program mode. After exiting program mode, the watchdog timer setting is also cleared. The operating mode is then switched to program-verify mode by setting the PV bit in FLMCR1. Before reading in program-verify mode, a dummy write of H'FF data should be made to the addresses to be read. The dummy write should be executed after the elapse of (t_{spv}) μ s or more. When the flash memory is read in this state (verify data is read in 16-bit units), the data at the latched address is read. Wait at least (t_{spvr}) μ s after the dummy write before performing this read operation. Next, the originally written data is compared with the verify data, and reprogram data is computed (see figure 21A-12) and transferred to RAM. After verification of 128 bytes of data has been completed, exit program-verify mode, wait for at least (t_{cpv}) μ s, then clear the SWE bit in FLMCR1. If reprogramming is necessary, set program mode again, and repeat the program/program-verify sequence as before. The maximum number of repetitions of the program/program-verify sequence is indicated by the maximum programming count (N). Leave a wait time of at least (t_{cswe}) μ s after clearing SWE.

Notes on Program/Program-Verify Procedure

1. In order to perform 128-byte-unit programming, the lower 8 bits of the write start address must be H'00 or H'80.
2. When performing continuous writing of 128-byte data to flash memory, byte-unit transfer should be used.
128-byte data transfer is necessary even when writing fewer than 128 bytes of data. Write H'FF data to the extra addresses.
3. Verify data is read in word units.
4. The write pulse is applied and a flash memory write executed while the P bit in FLMCR1 is set. In the chip, write pulses should be applied as follows in the program/program-verify procedure to prevent voltage stress on the device and loss of write data reliability.
 - a. After write pulse application, perform a verify-read in program-verify mode and apply a write pulse again for any bits read as 1 (reprogramming processing). When all the 0-write bits in the 128-byte write data are read as 0 in the verify-read operation, the program/program-verify procedure is completed. In the chip, the number of loops in reprogramming processing is guaranteed not to exceed the maximum value of the maximum programming count (N).

- b. After write pulse application, a verify-read is performed in program-verify mode, and programming is judged to have been completed for bits read as 0. The following processing is necessary for programmed bits.

When programming is completed at an early stage in the program/program-verify procedure:

If programming is completed in the 1st to 6th reprogramming processing loop, additional programming should be performed on the relevant bits. Additional programming should only be performed on bits which first return 0 in a verify-read in certain reprogramming processing.

When programming is completed at a late stage in the program/program-verify procedure:

If programming is completed in the 7th or later reprogramming processing loop, additional programming is not necessary for the relevant bits.

- c. If programming of other bits is incomplete in the 128 bytes, reprogramming processing should be executed. If a bit for which programming has been judged to be completed is read as 1 in a subsequent verify-read, a write pulse should again be applied to that bit.
5. The period for which the P bit in FLMCR1 is set (the write pulse width) should be changed according to the degree of progress through the program/program-verify procedure. For detailed wait time specifications, see section 24.1.7, Flash Memory Characteristics.

Item	Symbol	Item	Symbol
Wait time after P bit setting	t_{sp}	When reprogramming loop count (n) is 1 to 6	t_{sp30}
		When reprogramming loop count (n) is 7 or more	t_{sp200}
		In case of additional programming processing*	t_{sp10}

Note: *Additional programming processing is necessary only when the reprogramming loop count (n) is 1 to 6.

6. The program/program-verify flowchart for the H8S/2636 is shown in figure 21A-12. To cover the points noted above, bits on which reprogramming processing is to be executed, and bits on which additional programming is to be executed, must be determined as shown below.
- Since reprogram data and additional-programming data vary according to the progress of the programming procedure, it is recommended that the following data storage areas (128 bytes each) be provided in RAM.

Reprogram Data Computation Table

(D)	Result of Verify-Read after Write Pulse Application (V)	(X) Result of Operation	Comments
0	0	1	Programming completed: reprogramming processing not to be executed
0	1	0	Programming incomplete: reprogramming processing to be executed
1	0	1	—
1	1	1	Still in erased state: no action

Legend:

(D): Source data of bits on which programming is executed

(X): Source data of bits on which reprogramming is executed

Additional-Programming Data Computation Table

(X')	Result of Verify-Read after Write Pulse Application (V)	(Y) Result of Operation	Comments
0	0	0	Programming by write pulse application judged to be completed: additional programming processing to be executed
0	1	1	Programming by write pulse application incomplete: additional programming processing not to be executed
1	0	1	Programming already completed: additional programming processing not to be executed
1	1	1	Still in erased state: no action

Legend:

(Y): Data of bits on which additional programming is executed

(X'): Data of bits on which reprogramming is executed in a certain reprogramming loop

- It is necessary to execute additional programming processing during the course of the chip program/program-verify procedure. However, once 128-byte-unit programming is finished, additional programming should not be carried out on the same address area. When executing reprogramming, an erase must be executed first. Note that normal operation of reads, etc., is not guaranteed if additional programming is performed on addresses for which a program/program-verify operation has finished.

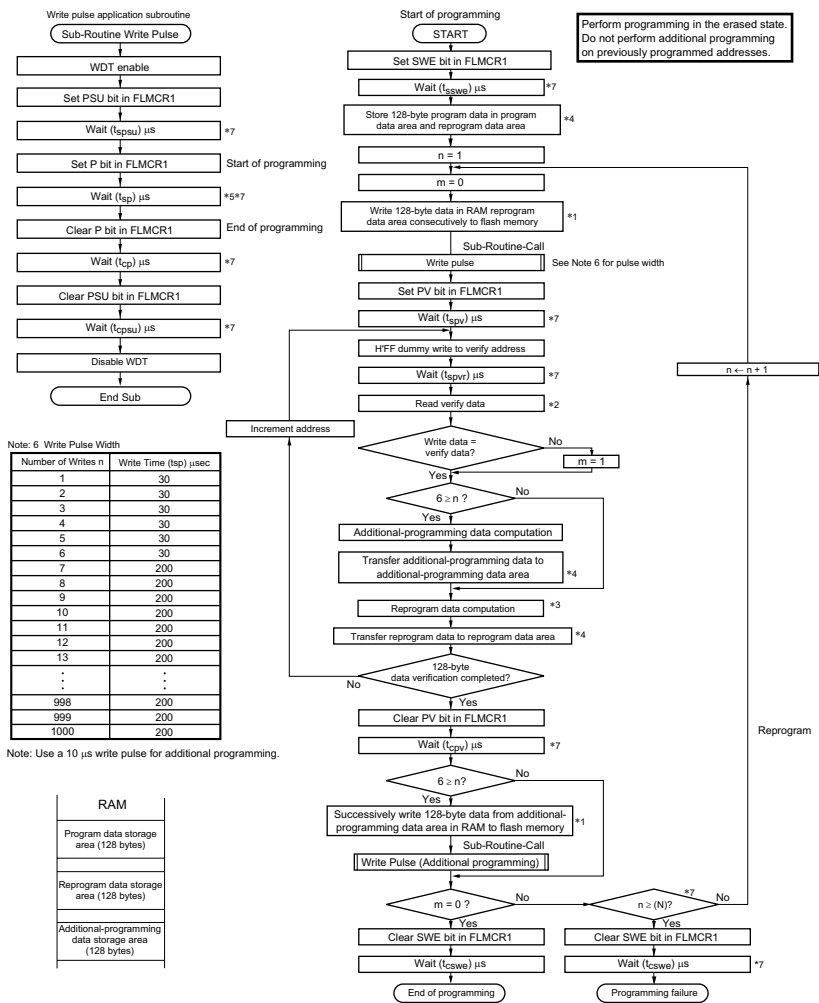

Note: 6 Write Pulse Width

Number of Writes n	Write Time (t _{wp}) μsec
1	30
2	30
3	30
4	30
5	30
6	30
7	200
8	200
9	200
10	200
11	200
12	200
13	200
·	·
·	·
·	·
998	200
999	200
1000	200

Note: Use a 10 μs write pulse for additional programming.

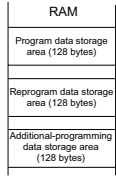

- Notes:
- Data transfer is performed by byte transfer. The lower 8 bits of the first address written to must be H00 or H80. A 128-byte data transfer must be performed even if writing fewer than 128 bytes; in this case, HFF data must be written to the extra addresses.
 - Verify data is read in 16-bit (word) units.
 - Reprogram data is determined by the operation shown in the table below (comparison between the data stored in the program data area and the verify data). Bits for which the reprogram data is 0 are programmed in the next reprogramming loop. Therefore, even bits for which programming has been completed will be subjected to programming once again if the result of the subsequent verify operation is NG.
 - A 128-byte area for storing program data, a 128-byte area for storing reprogram data, and a 128-byte area for storing additional data must be provided in RAM. The contents of the reprogram data area and additional data area are modified as programming proceeds.
 - A write pulse of 30 μs or 200 μs is applied according to the progress of the programming operation. See Note 6 for details of the pulse widths. When writing of additional-programming data is executed, a 10 μs write pulse should be applied. Reprogram data X means reprogram data when the write pulse is applied.
 - The wait times and value of N are shown in section 24.1.7, Flash Memory Characteristics.

Reprogram Data Computation Table

Original Data (D)	Verify Data (V)	Reprogram Data (X)	Comments
0	0	1	Programming completed
0	1	0	Programming incomplete; reprogram
1	0	1	
1	1	1	Still in erased state; no action

Additional-Programming Data Computation Table

Reprogram Data (X)	Verify Data (V)	Additional-Programming Data (Y)	Comments
0	0	0	Additional programming to be executed
0	1	1	Additional programming not to be executed
1	0	1	Additional programming not to be executed
1	1	1	Additional programming not to be executed

Figure 21A-12 Program/Program-Verify Flowchart



21A.9.3 Erase Mode

When erasing flash memory, the single-block erase flowchart shown in figure 21A-13 should be followed.

The wait times after bits are set or cleared in the flash memory control register 1 (FLMCR1) and the maximum number of erase operations (N) are shown in table 24-10 in section 24.1.7, Flash Memory Characteristics.

To erase flash memory contents, make a 1-bit setting for the flash memory area to be erased in erase block register 1 and 2 (EBR1, EBR2) at least (t_{sswe}) μ s after setting the SWE bit to 1 in FLMCR1. Next, the watchdog timer (WDT) is set to prevent overerasing due to program runaway, etc. Set a value greater than (t_{se}) ms + ($t_{sesu} + t_{ce} + t_{cesu}$) μ s as the WDT overflow period. Preparation for entering erase mode (erase setup) is performed next by setting the ESU bit in FLMCR1. The operating mode is then switched to erase mode by setting the E bit in FLMCR1 after the elapse of at least (t_{sesu}) μ s. The time during which the E bit is set is the flash memory erase time. Ensure that the erase time does not exceed (t_{se}) ms.

Note: With flash memory erasing, preprogramming (setting all memory data in the memory to be erased to all 0) is not necessary before starting the erase procedure.

21A.9.4 Erase-Verify Mode

In erase-verify mode, data is read after memory has been erased to check whether it has been correctly erased.

After the elapse of the fixed erase time, clear the E bit in FLMCR1, then wait for at least (t_{ce}) μ s before clearing the ESU bit to exit erase mode. After exiting erase mode, the watchdog timer setting is also cleared. The operating mode is then switched to erase-verify mode by setting the EV bit in FLMCR1. Before reading in erase-verify mode, a dummy write of H'FF data should be made to the addresses to be read. The dummy write should be executed after the elapse of (t_{sev}) μ s or more. When the flash memory is read in this state (verify data is read in 16-bit units), the data at the latched address is read. Wait at least (t_{sevr}) μ s after the dummy write before performing this read operation. If the read data has been erased (all 1), a dummy write is performed to the next address, and erase-verify is performed. If the read data is unerased, set erase mode again, and repeat the erase/erase-verify sequence as before. The maximum number of repetitions of the erase/erase-verify sequence is indicated by the maximum erase count (N). When verification is completed, exit erase-verify mode, and wait for at least (t_{cev}) μ s. If erasure has been completed on all the erase blocks, clear the SWE bit in FLMCR1, and leave a wait time of at least (t_{cswe}) μ s.

If erasing multiple blocks, set a single bit in EBR1/EBR2 for the next block to be erased, and repeat the erase/erase-verify sequence as before.

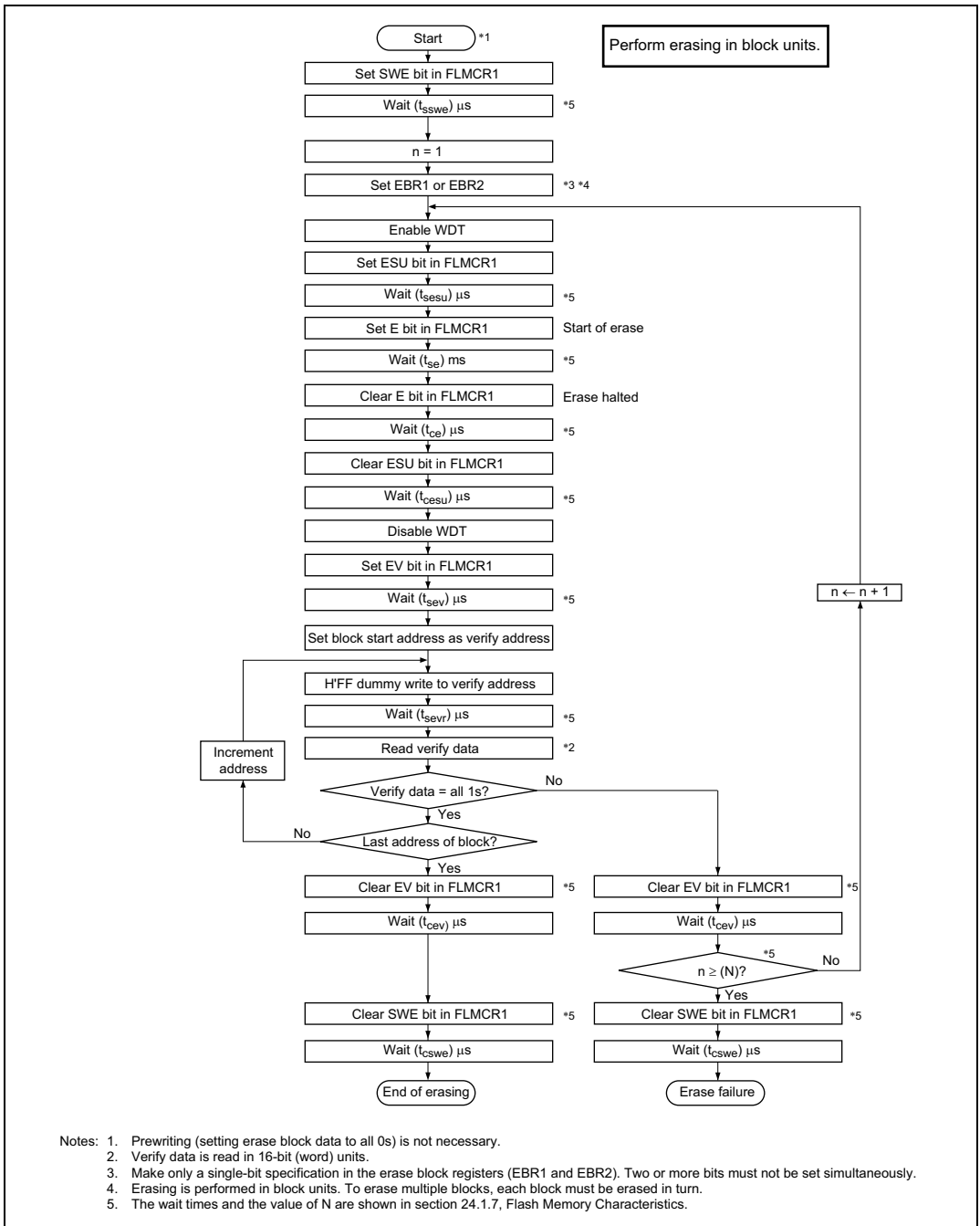

Figure 21A-13 Erase/Erase-Verify Flowchart

21A.10 Protection

There are three kinds of flash memory program/erase protection: hardware protection, software protection, and error protection.

21A.10.1 Hardware Protection

Hardware protection refers to a state in which programming/erasing of flash memory is forcibly disabled or aborted. Hardware protection is reset by settings in flash memory control register 1 (FLMCR1), flash memory control register 2 (FLMCR2), erase block register 1 (EBR1), and erase block register 2 (EBR2). The FLMCR1, FLMCR2, EBR1, and EBR2 settings are retained in the error-protected state (See table 21A-11).

Table 21A-11 Hardware Protection

Item	Description	Functions	
		Program	Erase
FWE pin protection	<ul style="list-style-type: none"> When a low level is input to the FWE pin, FLMCR1, FLMCR2, (except bit FLER) EBR1, and EBR2 are initialized, and the program/erase-protected state is entered. 	Yes	Yes
Reset/standby protection	<ul style="list-style-type: none"> In a reset (including a WDT reset) and in standby mode, FLMCR1, FLMCR2, EBR1, and EBR2 are initialized, and the program/erase-protected state is entered. In a reset via the $\overline{\text{RES}}$ pin, the reset state is not entered unless the $\overline{\text{RES}}$ pin is held low until oscillation stabilizes after powering on. In the case of a reset during operation, hold the $\overline{\text{RES}}$ pin low for the $\overline{\text{RES}}$ pulse width specified in the AC Characteristics section. 	Yes	Yes

21A.10.2 Software Protection

Software protection can be implemented by setting the SWE bit in FLMCR1, erase block register 1 (EBR1), erase block register 2 (EBR2), and the RAMS bit in the RAM emulation register (RAMER). When software protection is in effect, setting the P or E bit in flash memory control register 1 (FLMCR1), does not cause a transition to program mode or erase mode (See table 21A-12).

Table 21A-12 Software Protection

Item	Description	Functions	
		Program	Erase
SWE bit protection	<ul style="list-style-type: none"> Setting bit SWE1 in FLMCR1 to 0 will place area on-chip flash memory in the program/erase-protected state (Execute the program in the on-chip RAM, external memory). 	Yes	Yes
Block specification protection	<ul style="list-style-type: none"> Erase protection can be set for individual blocks by settings in erase block register 1 (EBR1) and erase block register 2 (EBR2). Setting EBR1 and EBR2 to H'00 places all blocks in the erase-protected state. 	—	Yes
Emulation protection	<ul style="list-style-type: none"> Setting the RAMS bit to 1 in the RAM emulation register (RAMER) places all blocks in the program/erase-protected state. 	Yes	Yes

21A.10.3 Error Protection

In error protection, an error is detected when chip runaway occurs during flash memory programming/erasing, or operation is not performed in accordance with the program/erase algorithm, and the program/erase operation is aborted. Aborting the program/erase operation prevents damage to the flash memory due to overprogramming or overerasing.

If the chip malfunctions during flash memory programming/erasing, the FLER bit is set to 1 in FLMCR2 and the error protection state is entered. The FLMCR1, FLMCR2, EBR1, and EBR2 settings are retained, but program mode or erase mode is aborted at the point at which the error occurred. Program mode or erase mode cannot be re-entered by re-setting the P or E bit. However, PV and EV bit setting is enabled, and a transition can be made to verify mode.

FLER bit setting conditions are as follows:

1. When the flash memory of the relevant address area is read during programming/erasing (including vector read and instruction fetch)
2. Immediately after exception handling (excluding a reset) during programming/erasing
3. When a SLEEP instruction (including software standby) is executed during programming/erasing
4. When the CPU releases the bus to the DTC

Error protection is released only by a reset and in hardware standby mode.

Figure 21A-14 shows the flash memory state transition diagram.

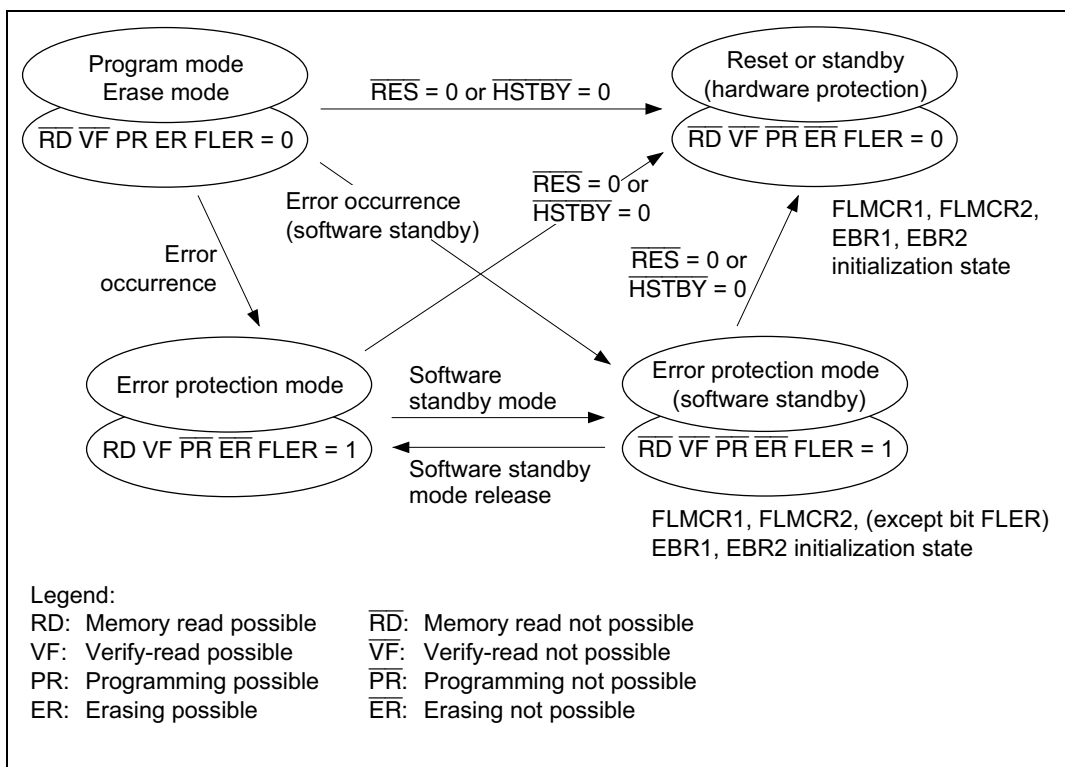

Figure 21A-14 Flash Memory State Transitions

21A.11 Flash Memory Emulation in RAM

Making a setting in the RAM emulation register (RAMER) enables part of RAM to be overlapped onto the flash memory area so that data to be written to flash memory can be emulated in RAM in real time. After the RAMER setting has been made, accesses cannot be made from the flash memory area or the RAM area overlapping flash memory. Emulation can be performed in user mode and user program mode. Figure 21A-15 shows an example of emulation of real-time flash memory programming.

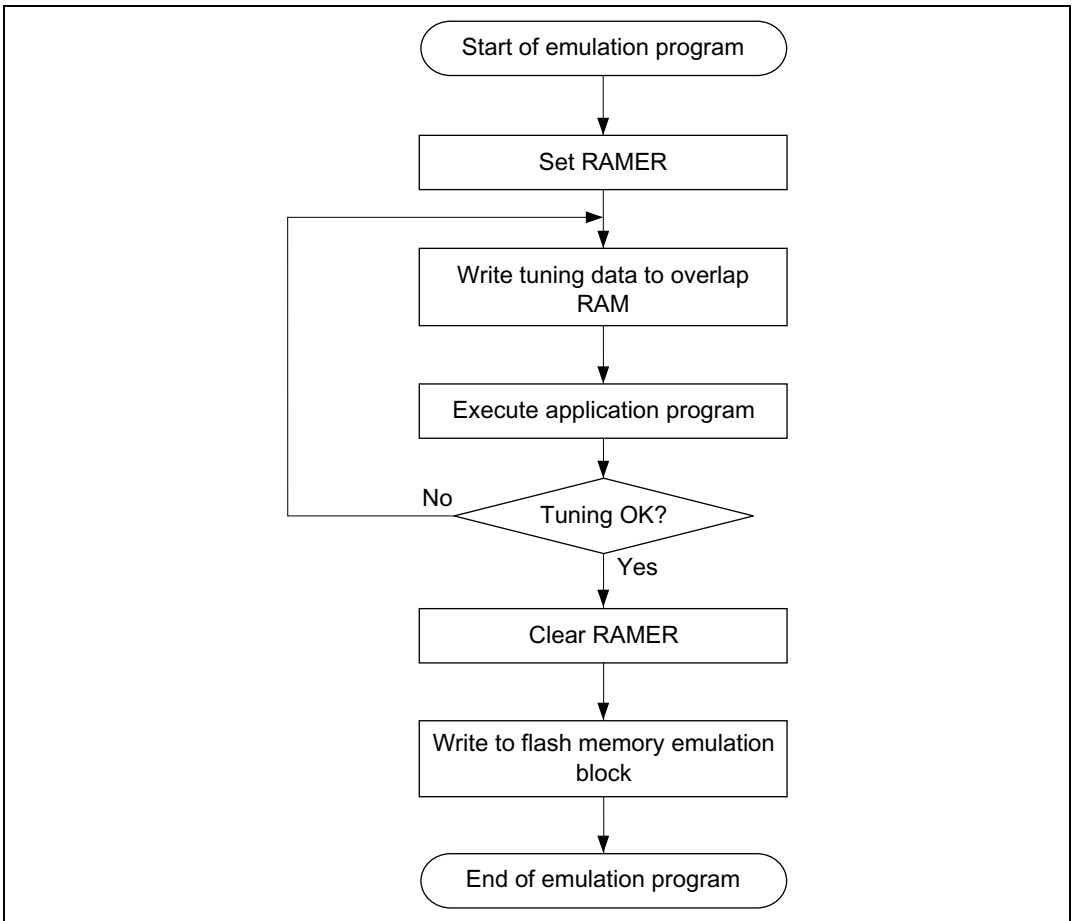

Figure 21A-15 Flowchart for Flash Memory Emulation in RAM

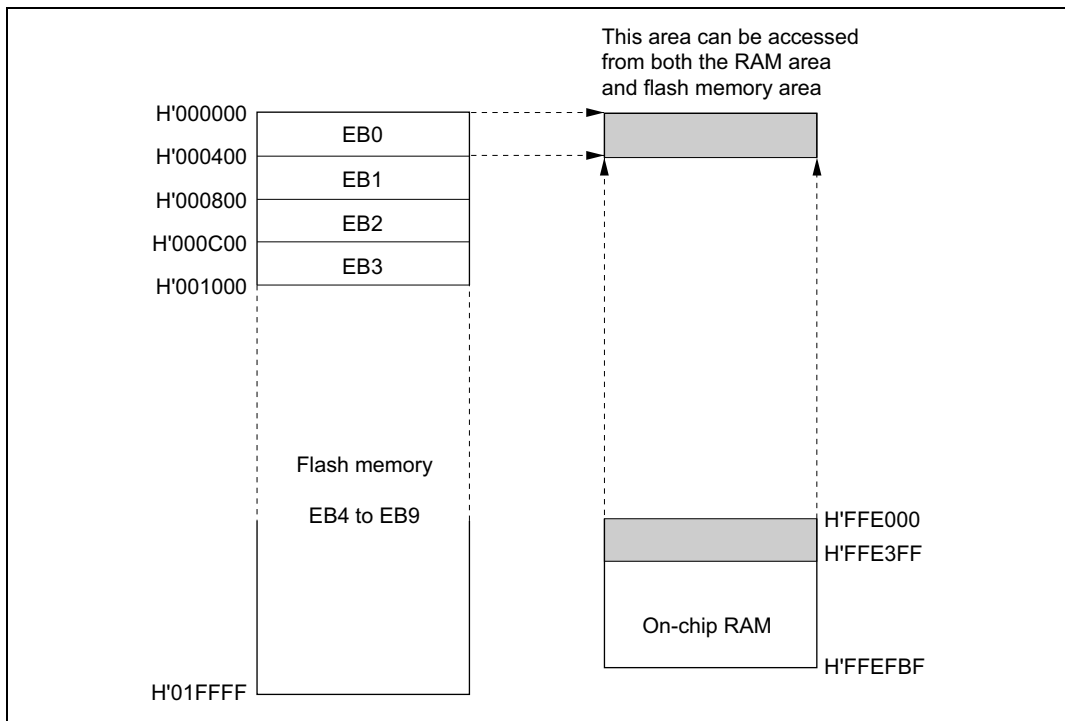

Figure 21A-16 Example of RAM Overlap Operation

Example in which Flash Memory Block Area EB0 is Overlapped

1. Set bits RAMS, RAM2 to RAM0 in RAMER to 1, 0, 0, 0, to overlap part of RAM onto the area (EB0) for which real-time programming is required.
2. Real-time programming is performed using the overlapping RAM.
3. After the program data has been confirmed, the RAMS bit is cleared, releasing RAM overlap.
4. The data written in the overlapping RAM is written into the flash memory space (EB0).

- Notes:
1. When the RAMS bit is set to 1, program/erase protection is enabled for all blocks regardless of the value of RAM2 to RAM0 (emulation protection). In this state, setting the P or E bit in flash memory control register 1 (FLMCR1), will not cause a transition to program mode or erase mode. When actually programming or erasing a flash memory area, the RAMS bit should be cleared to 0.
 2. A RAM area cannot be erased by execution of software in accordance with the erase algorithm while flash memory emulation in RAM is being used.
 3. Block area EB0 contains the vector table. When performing RAM emulation, the vector table is needed in the overlap RAM.

21A.12 Interrupt Handling when Programming/Erasing Flash Memory

All interrupts, including NMI interrupt is disabled when flash memory is being programmed or erased (when the P or E bit is set in FLMCR1), and while the boot program is executing in boot mode^{*1}, to give priority to the program or erase operation. There are three reasons for this:

1. Interrupt during programming or erasing might cause a violation of the programming or erasing algorithm, with the result that normal operation could not be assured.
2. In the interrupt exception handling sequence during programming or erasing, the vector would not be read correctly^{*2}, possibly resulting in MCU runaway.
3. If interrupt occurred during boot program execution, it would not be possible to execute the normal boot mode sequence.

For these reasons, in on-board programming mode alone there are conditions for disabling interrupt, as an exception to the general rule. However, this provision does not guarantee normal erasing and programming or MCU operation. All requests, including NMI interrupt, must therefore be restricted inside and outside the MCU when programming or erasing flash memory. NMI interrupt is also disabled in the error-protection state while the P or E bit remains set in FLMCR1.

- Notes:
1. Interrupt requests must be disabled inside and outside the MCU until the programming control program has completed programming.
 2. The vector may not be read correctly in this case for the following two reasons:
 - If flash memory is read while being programmed or erased (while the P or E bit is set in FLMCR1), correct read data will not be obtained (undetermined values will be returned).
 - If the interrupt entry in the vector table has not been programmed yet, interrupt exception handling will not be executed correctly.

21A.13 Flash Memory Programmer Mode

Programs and data can be written and erased in programmer mode as well as in the on-board programming modes. In programmer mode, flash memory read mode, auto-program mode, auto-erase mode, and status read mode are supported. In auto-program mode, auto-erase mode, and status read mode, a status polling procedure is used, and in status read mode, detailed internal signals are output after execution of an auto-program or auto-erase operation.

In programmer mode, set the mode pins to programmer mode (see table 21A-13) and input a 12 MHz input clock.

Table 21A-13 shows the pin settings for programmer mode.

Table 21A-13 Programmer Mode Pin Settings

Pin Names	Settings
Mode pins: MD2, MD1, MD0	Low level input to MD2, MD1, and MD0.
Mode setting pins: PF0, P16, P14	High level input to PF0, low level input to P16 and P14
FWE pin	High level input (in auto-program and auto-erase modes)
$\overline{\text{RES}}$ pin	Reset circuit
XTAL, EXTAL, PLLCAP, PLLVSS pins	Oscillator circuit
VCL	Internal voltage step-down circuit

21A.13.1 Socket Adapter and Memory Map

In programmer mode in which the PROM writer is used, reading from memory (verification), writing, and initializing the flash memory (erasing all of its contents) are enabled. At this time, a dedicated conversion socket adapter must be attached to a general-purpose PROM writer. Table 21A-14 shows the types of the socket adapters. For programmer mode on this LSI, one of the socket adapters listed in table 21A-14 should be used.

Table 21A-14 Type of Socket Adapter

Product Name	Package Type	Socket Adapter Type	Manufacturer
HD64F2636UF	128 pin QFP	ME2636ESHF1H	Minato Electronics Inc.
HD64F2636F	(FP-128B)	HF2636Q128D4001	Data I/O Japan Corporation

The memory map of on-chip ROM is shown in figure 21A-17

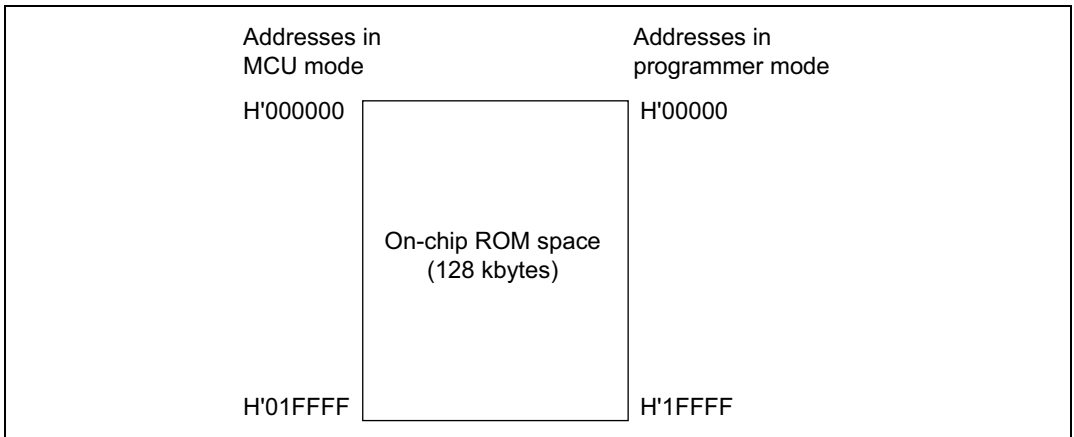

Figure 21A-17 On-Chip ROM Memory Map

21A.13.2 Programmer Mode Operation

Table 21A-15 shows how the different operating modes are set when using programmer mode, and table 21A-16 lists the commands used in programmer mode. Details of each mode are given below.

- **Memory Read Mode**
Memory read mode supports byte reads.
- **Auto-Program Mode**
Auto-program mode supports programming of 128 bytes at a time. Status polling is used to confirm the end of auto-programming.
- **Auto-Erase Mode**
Auto-erase mode supports automatic erasing of the entire flash memory. Status polling is used to confirm the end of auto-programming.
- **Status Read Mode**
Status polling is used for auto-programming and auto-erasing, and normal termination can be confirmed by reading the I/O6 signal. In status read mode, error information is output if an error occurs.

Table 21A-15 Settings for Various Operating Modes in Programmer Mode

Mode	Pin Names				I/O7 to I/O0	A18 to A0
	FWE	\overline{CE}	\overline{OE}	\overline{WE}		
Read	H or L	L	L	H	Data output	Ain ^{*2}
Output disable	H or L	L	H	H	Hi-Z	X
Command write	H or L ^{*3}	L	H	L	Data input	Ain ^{*2}
Chip disable ^{*1}	H or L	H	X	X	Hi-Z	X

- Notes: 1. Chip disable is not a standby state; internally, it is an operation state.
 2. Ain indicates that there is also address input in auto-program mode.
 3. For command writes in auto-program and auto-erase modes, input a high level to the FWE pin.

Table 21A-16 Programmer Mode Commands

Command Name	Number of Cycles	1st Cycle			2nd Cycle		
		Mode	Address	Data	Mode	Address	Data
Memory read mode	1 + n	Write	X	H'00	Read	RA	Dout
Auto-program mode	129	Write	X	H'40	Write	WA	Din
Auto-erase mode	2	Write	X	H'20	Write	X	H'20
Status read mode	2	Write	X	H'71	Write	X	H'71

- Notes: 1. In auto-program mode, 129 cycles are required for command writing by a simultaneous 128-byte write.
 2. In memory read mode, the number of cycles depends on the number of address write cycles (n).

21A.13.3 Memory Read Mode

1. After completion of auto-program/auto-erase/status read operations, a transition is made to the command wait state. When reading memory contents, a transition to memory read mode must first be made with a command write, after which the memory contents are read.
2. In memory read mode, command writes can be performed in the same way as in the command wait state.
3. Once memory read mode has been entered, consecutive reads can be performed.
4. After powering on, memory read mode is entered.

Table 21A-17 AC Characteristics in Transition to Memory Read ModeConditions: $V_{CC} = 5.0 \text{ V} \pm 0.5 \text{ V}$, $V_{SS} = 0 \text{ V}$, $T_a = 25^\circ\text{C} \pm 5^\circ\text{C}$

Item	Symbol	Min.	Max.	Unit
Command write cycle	t_{nxtc}	20	—	μs
$\overline{\text{CE}}$ hold time	t_{ceh}	0	—	ns
$\overline{\text{CE}}$ setup time	t_{ces}	0	—	ns
Data hold time	t_{dh}	50	—	ns
Data setup time	t_{ds}	50	—	ns
Write pulse width	t_{wep}	70	—	ns
$\overline{\text{WE}}$ rise time	t_r	—	30	ns
$\overline{\text{WE}}$ fall time	t_f	—	30	ns

**Figure 21A-18 Timing Waveforms for Memory Read after Memory Write**

Table 21A-18 AC Characteristics in Transition from Memory Read Mode to Another ModeConditions: $V_{CC} = 5.0\text{ V} \pm 0.5\text{ V}$, $V_{SS} = 0\text{ V}$, $T_a = 25^\circ\text{C} \pm 5^\circ\text{C}$

Item	Symbol	Min.	Max.	Unit
Command write cycle	t_{nxtc}	20	—	μs
$\overline{\text{CE}}$ hold time	t_{ceh}	0	—	ns
$\overline{\text{CE}}$ setup time	t_{ces}	0	—	ns
Data hold time	t_{dh}	50	—	ns
Data setup time	t_{ds}	50	—	ns
Write pulse width	t_{wep}	70	—	ns
$\overline{\text{WE}}$ rise time	t_r	—	30	ns
$\overline{\text{WE}}$ fall time	t_f	—	30	ns

**Figure 21A-19 Timing Waveforms in Transition from Memory Read Mode to Another Mode**

Table 21A-19 AC Characteristics in Memory Read ModeConditions: $V_{CC} = 5.0 \text{ V} \pm 0.5 \text{ V}$, $V_{SS} = 0 \text{ V}$, $T_a = 25^\circ\text{C} \pm 5^\circ\text{C}$

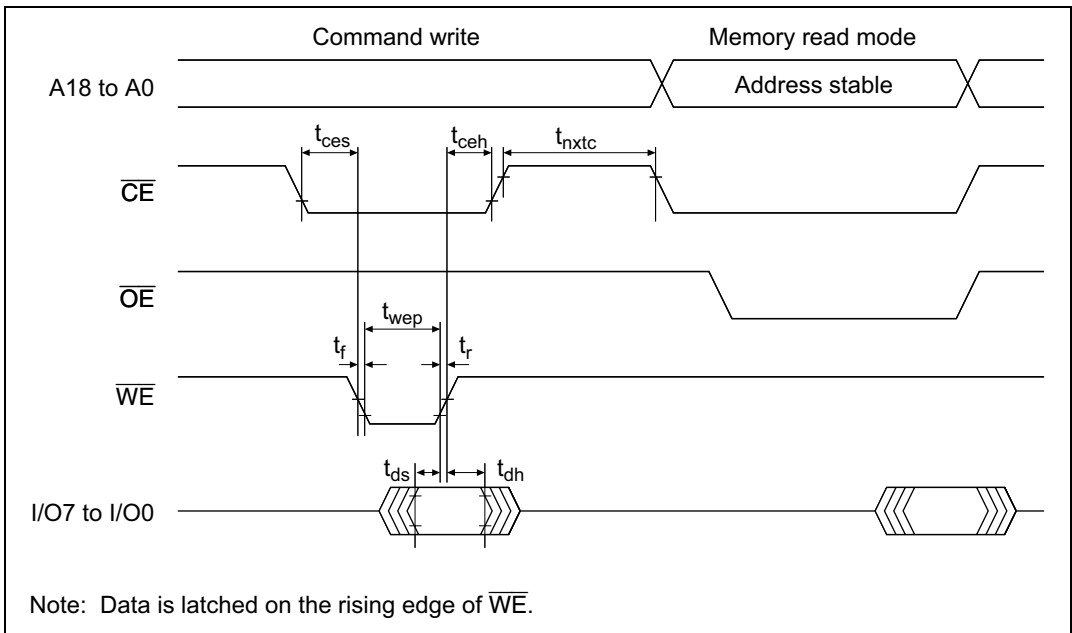
Item	Symbol	Min.	Max.	Unit
Access time	t_{acc}	—	20	μs
$\overline{\text{CE}}$ output delay time	t_{ce}	—	150	ns
$\overline{\text{OE}}$ output delay time	t_{oe}	—	150	ns
Output disable delay time	t_{df}	—	100	ns
Data output hold time	t_{oh}	5	—	ns

**Figure 21A-20 $\overline{\text{CE}}$ and $\overline{\text{OE}}$ Enable State Read Timing Waveforms****Figure 21A-21 $\overline{\text{CE}}$ and $\overline{\text{OE}}$ Clock System Read Timing Waveforms**

21A.13.4 Auto-Program Mode

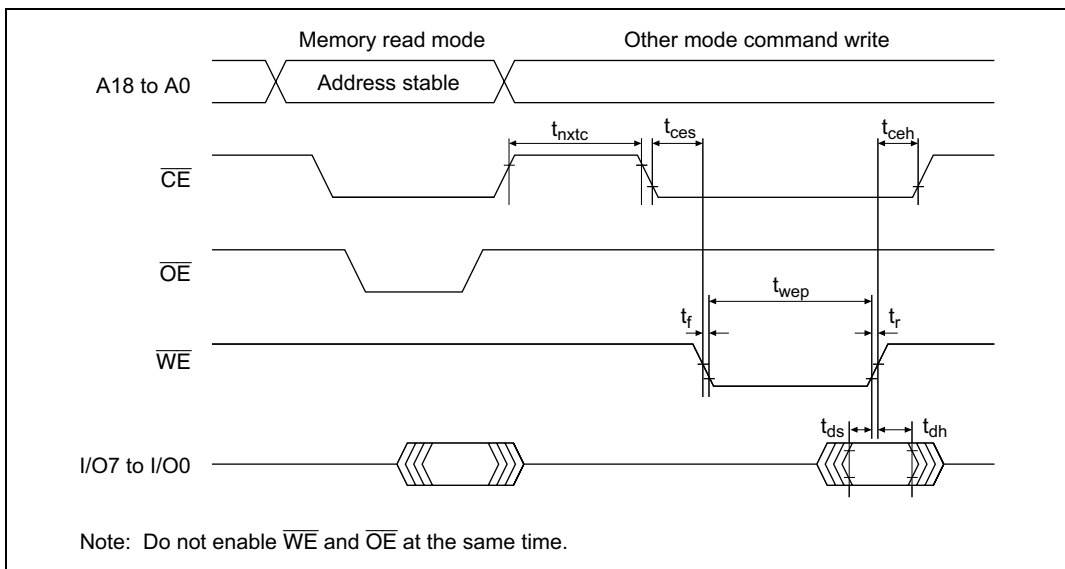
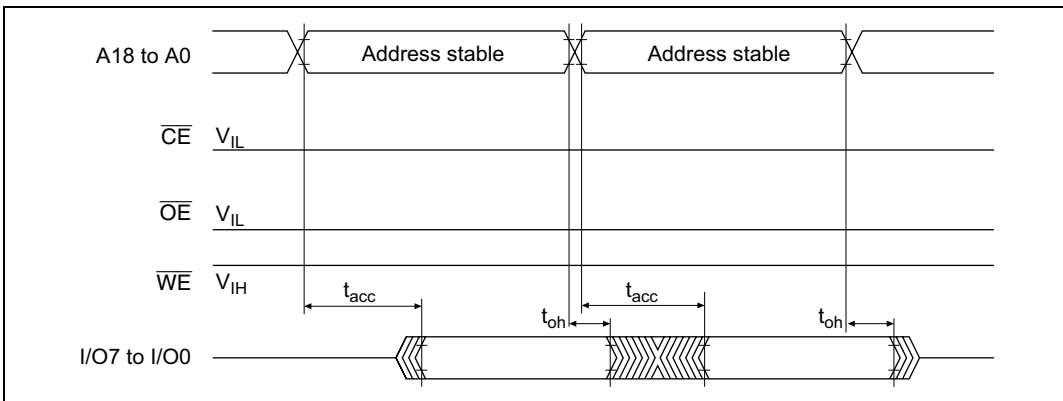
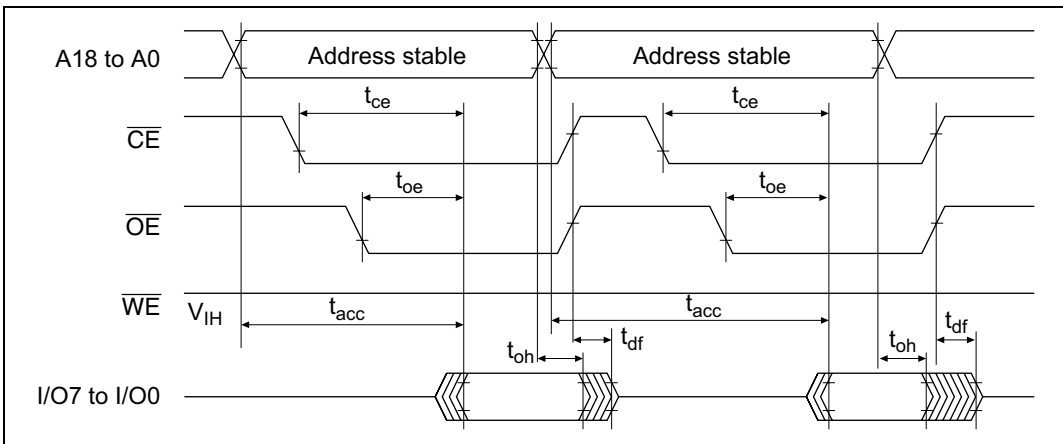
1. In auto-program mode, 128 bytes are programmed simultaneously. This should be carried out by executing 128 consecutive byte transfers.
2. A 128-byte data transfer is necessary even when programming fewer than 128 bytes. In this case, H'FF data must be written to the extra addresses.
3. The lower 7 bits of the transfer address must be low. If a value other than an effective address is input, processing will switch to a memory write operation but a write error will be flagged.
4. Memory address transfer is performed in the second cycle (figure 21A-22). Do not perform transfer after the third cycle.
5. Do not perform a command write during a programming operation.
6. Perform one auto-program operation for a 128-byte block for each address. Two or more additional programming operations cannot be performed on a previously programmed address block.
7. Confirm normal end of auto-programming by checking I/O6. Alternatively, status read mode can also be used for this purpose (I/O7 status polling uses the auto-program operation end decision pin).
8. Status polling I/O6 and I/O7 pin information is retained until the next command write. As long as the next command write has not been performed, reading is possible by enabling \overline{CE} and \overline{OE} .

Table 21A-20 AC Characteristics in Auto-Program ModeConditions: $V_{CC} = 5.0 \text{ V} \pm 0.5 \text{ V}$, $V_{SS} = 0 \text{ V}$, $T_a = 25^\circ\text{C} \pm 5^\circ\text{C}$

Item	Symbol	Min.	Max.	Unit
Command write cycle	t_{nxtc}	20	—	μs
$\overline{\text{CE}}$ hold time	t_{ceh}	0	—	ns
$\overline{\text{CE}}$ setup time	t_{ces}	0	—	ns
Data hold time	t_{dh}	50	—	ns
Data setup time	t_{ds}	50	—	ns
Write pulse width	t_{wep}	70	—	ns
Status polling start time	t_{wsts}	1	—	ms
Status polling access time	t_{spa}	—	150	ns
Address setup time	t_{as}	0	—	ns
Address hold time	t_{ah}	60	—	ns
Memory write time	t_{write}	1	3000	ms
Write setup time	t_{pns}	100	—	ns
Write end setup time	t_{pnh}	100	—	ns
$\overline{\text{WE}}$ rise time	t_r	—	30	ns
$\overline{\text{WE}}$ fall time	t_f	—	30	ns

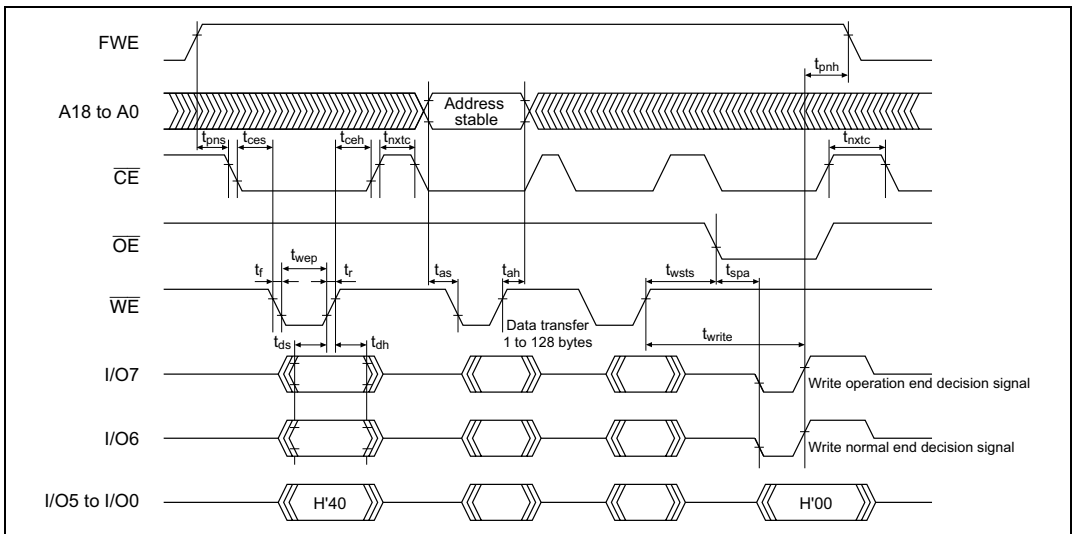
**Figure 21A-22 Auto-Program Mode Timing Waveforms**

21A.13.5 Auto-Erase Mode

1. Auto-erase mode supports only entire memory erasing.
2. Do not perform a command write during auto-erasing.
3. Confirm normal end of auto-erasing by checking I/O6. Alternatively, status read mode can also be used for this purpose (I/O7 status polling uses the auto-erase operation end decision pin).
4. Status polling I/O6 and I/O7 pin information is retained until the next command write. As long as the next command write has not been performed, reading is possible by enabling $\overline{\text{CE}}$ and $\overline{\text{OE}}$.

Table 21A-21 AC Characteristics in Auto-Erase Mode

Conditions: $V_{CC} = 5.0 \text{ V} \pm 0.5 \text{ V}$, $V_{SS} = 0 \text{ V}$, $T_a = 25^\circ\text{C} \pm 5^\circ\text{C}$

Item	Symbol	Min.	Max.	Unit
Command write cycle	t_{nxtc}	20	—	μs
$\overline{\text{CE}}$ hold time	t_{ceh}	0	—	ns
$\overline{\text{CE}}$ setup time	t_{ces}	0	—	ns
Data hold time	t_{dh}	50	—	ns
Data setup time	t_{ds}	50	—	ns
Write pulse width	t_{wep}	70	—	ns
Status polling start time	t_{ests}	1	—	ms
Status polling access time	t_{spa}	—	150	ns
Memory erase time	t_{erase}	100	40000	ms
Erase setup time	t_{ens}	100	—	ns
Erase end setup time	t_{enh}	100	—	ns
$\overline{\text{WE}}$ rise time	t_r	—	30	ns
$\overline{\text{WE}}$ fall time	t_f	—	30	ns

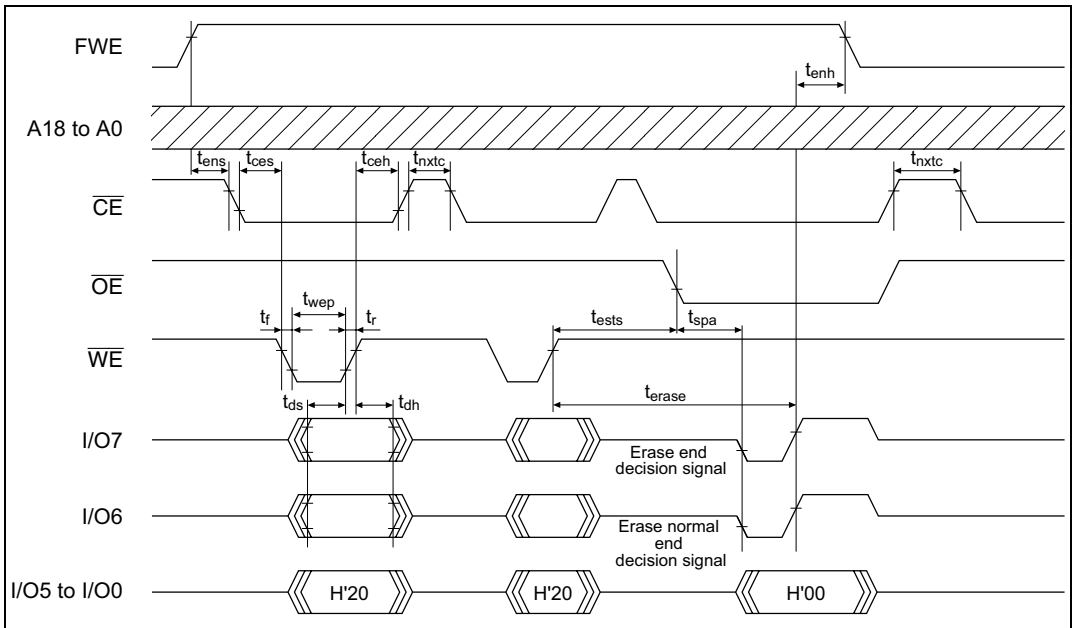

Figure 21A-23 Auto-Erase Mode Timing Waveforms

21A.13.6 Status Read Mode

1. Status read mode is provided to identify the kind of abnormal end. Use this mode when an abnormal end occurs in auto-program mode or auto-erase mode.
2. The return code is retained until a command write other than a status read mode command write is executed.

Table 21A-22 AC Characteristics in Status Read Mode

Conditions: $V_{CC} = 5.0\text{ V} \pm 0.5\text{ V}$, $V_{SS} = 0\text{ V}$, $T_a = 25^\circ\text{C} \pm 5^\circ\text{C}$

Item	Symbol	Min.	Max.	Unit
Read time after command write	t_{std}	20	—	μs
$\overline{\text{CE}}$ hold time	t_{ceh}	0	—	ns
$\overline{\text{CE}}$ setup time	t_{ces}	0	—	ns
Data hold time	t_{dh}	50	—	ns
Data setup time	t_{ds}	50	—	ns
Write pulse width	t_{wep}	70	—	ns
$\overline{\text{OE}}$ output delay time	t_{oe}	—	150	ns
Disable delay time	t_{df}	—	100	ns
$\overline{\text{CE}}$ output delay time	t_{ce}	—	150	ns
$\overline{\text{WE}}$ rise time	t_r	—	30	ns
$\overline{\text{WE}}$ fall time	t_f	—	30	ns

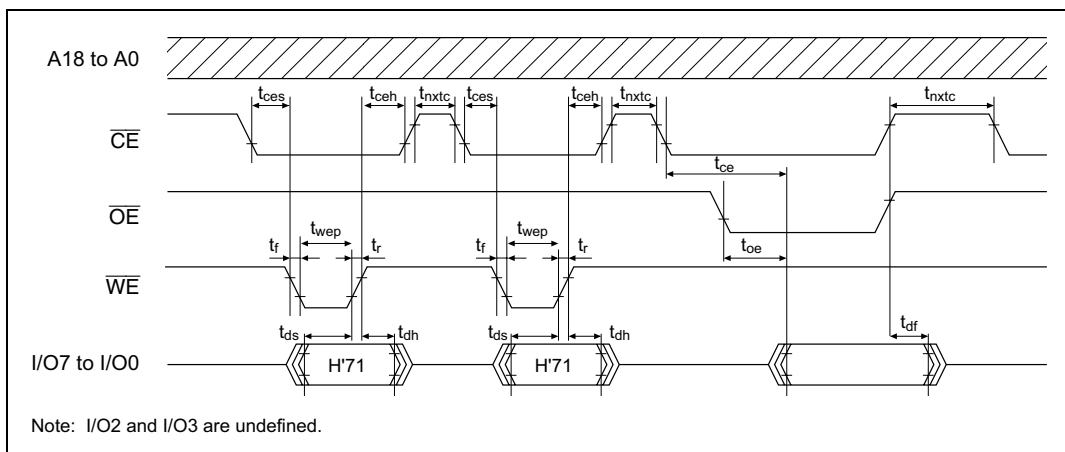

Figure 21A-24 Status Read Mode Timing Waveforms

Table 21A-23 Status Read Mode Return Commands

Pin Name	I/O7	I/O6	I/O5	I/O4	I/O3	I/O2	I/O1	I/O0
Attribute	Normal end decision	Command error	Programming error	Erase error	—	—	Programming or erase count exceeded	Effective address error
Initial value	0	0	0	0	0	0	0	0
Indications	Normal end: 0 Abnormal end: 1	Command error: 1 Otherwise: 0	Programming error: 1 Otherwise: 0	Erasing error: 1 Otherwise: 0	—	—	Count exceeded: 1 Otherwise: 0	Effective address error: 1 Otherwise: 0

Note: I/O2 and I/O3 are undefined.

21A.13.7 Status Polling

1. The I/O7 status polling flag indicates the operating status in auto-program/auto-erase mode.
2. The I/O6 status polling flag indicates a normal or abnormal end in auto-program/auto-erase mode.

Table 21A-24 Status Polling Output Truth Table

Pin Name	During Internal Operation	Abnormal End	—	Normal End
I/O7	0	1	0	1
I/O6	0	0	1	1
I/O0 to I/O5	0	0	0	0

21A.13.8 Programmer Mode Transition Time

Commands cannot be accepted during the oscillation stabilization period or the programmer mode setup period. After the programmer mode setup time, a transition is made to memory read mode.

Table 21A-25 Stipulated Transition Times to Command Wait State

Item	Symbol	Min.	Max.	Unit
Standby release (oscillation stabilization time)	t_{osc1}	30	—	ms
Programmer mode setup time	t_{bmv}	10	—	ms
VCC hold time	t_{dwn}	0	—	ms

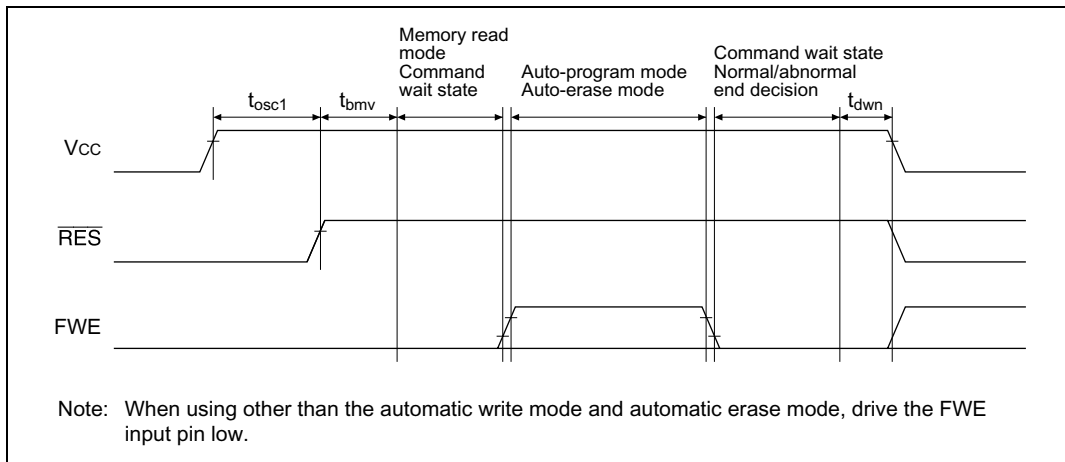

Figure 21A-25 Oscillation Stabilization Time, Boot Program Transfer Time, and Power-Down Sequence

21A.13.9 Notes on Memory Programming

1. When programming addresses which have previously been programmed, carry out auto-erasing before auto-programming.
2. When performing programming using programmer mode on a chip that has been programmed/erased in an on-board programming mode, auto-erasing is recommended before carrying out auto-programming.

Notes: 1. The flash memory is initially in the erased state when the device is shipped by Renesas Technology. For other chips for which the erasure history is unknown, it is recommended that auto-erasing be executed to check and supplement the initialization (erase) level.

2. Auto-programming should be performed once only on the same address block. Additional programming cannot be performed on previously programmed address blocks.

21A.14 Flash Memory and Power-Down States

In addition to its normal operating state, the flash memory has power-down states in which power consumption is reduced by halting part or all of the internal power supply circuitry.

There are three flash memory operating states:

- (1) Normal operating mode: The flash memory can be read and written to.
- (2) Power-down mode: Part of the power supply circuitry is halted, and the flash memory can be read when the LSI is operating on the subclock*.
- (3) Standby mode: All flash memory circuits are halted, and the flash memory cannot be read or written to.

States (2) and (3) are flash memory power-down states. Table 21A-26 shows the correspondence between the operating states of the LSI and the flash memory.

Table 21A-26 Flash Memory Operating States

LSI Operating State	Flash Memory Operating State
High-speed mode	Normal mode (read/write)
Medium-speed mode	
Sleep mode	
Subactive mode*	When PDWND = 0: Power-down mode (read-only)
Subsleep mode*	When PDWND = 1: Normal mode (read-only)
Watch mode*	Standby mode
Software standby mode	
Hardware standby mode	

Note: * Subclock functions (subactive mode, subsleep mode, and watch mode) are available in the U-mask version only.

These functions cannot be used with the other versions.

21A.14.1 Notes on Power-Down States

1. When the flash memory is in a power-down state, part or all of the internal power supply circuitry is halted. Therefore, a power supply circuit stabilization period must be provided when returning to normal operation. When the flash memory returns to its normal operating state from a power-down state, bits STS2 to STS0 in SBYCR must be set to provide a wait time of at least 20 μ s (power supply stabilization time), even if an oscillation stabilization period is not necessary.

2. In a power-down state, FLMCR1, FLMCR2, EBR1, EBR2, RAMER, and FLPWCR cannot be read from or written to.

21A.15 Flash Memory Programming and Erasing Precautions

Precautions concerning the use of on-board programming mode, the RAM emulation function, and programmer mode are summarized below.

1. Use the specified voltages and timing for programming and erasing.

Applied voltages in excess of the rating can permanently damage the device. Use a PROM programmer that supports the Renesas Technology microcomputer device type with 128-kbyte on-chip flash memory.

Only use the specified socket adapter. Failure to observe these points may result in damage to the device.

2. Powering on and off (see figures 21A-26 to 21A-28)

Do not apply a high level to the FWE pin until V_{CC} has stabilized. Also, drive the FWE pin low before turning off V_{CC} .

When applying or disconnecting V_{CC} power, fix the FWE pin low and place the flash memory in the hardware protection state.

The power-on and power-off timing requirements should also be satisfied in the event of a power failure and subsequent recovery.

3. FWE application/disconnection (see figures 21A-26 to 21A-28)

FWE application should be carried out when MCU operation is in a stable condition. If MCU operation is not stable, fix the FWE pin low and set the protection state.

The following points must be observed concerning FWE application and disconnection to prevent unintentional programming or erasing of flash memory:

- Apply FWE when the V_{CC} voltage has stabilized within its rated voltage range.
Apply FWE when oscillation has stabilized (after the elapse of the oscillation settling time).
- In boot mode, apply and disconnect FWE during a reset.
- In user program mode, FWE can be switched between high and low level regardless of a reset state.
FWE input can also be switched during execution of a program in flash memory.
- Do not apply FWE if program runaway has occurred.

- Disconnect FWE only when the SWE, ESU, PSU, EV, PV, P, and E bits in FLMCR1 are cleared.

Make sure that the SWE, ESU, PSU, EV, PV, P, and E bits are not set by mistake when applying or disconnecting FWE.

4. Do not apply a constant high level to the FWE pin.

Apply a high level to the FWE pin only when programming or erasing flash memory. A system configuration in which a high level is constantly applied to the FWE pin should be avoided. Also, while a high level is applied to the FWE pin, the watchdog timer should be activated to prevent overprogramming or overerasing due to program runaway, etc.

5. Use the recommended algorithm when programming and erasing flash memory.

The recommended algorithm enables programming and erasing to be carried out without subjecting the device to voltage stress or sacrificing program data reliability. When setting the P or E bit in FLMCR1, the watchdog timer should be set beforehand as a precaution against program runaway, etc.

6. Do not set or clear the SWE bit during execution of a program in flash memory.

Do not set or clear the SWE bit during execution of a program in flash memory. Wait for at least 100 μ s after clearing the SWE bit before executing a program or reading data in flash memory. When the SWE bit is set, data in flash memory can be rewritten, but when SWE = 1, flash memory can only be read in program-verify or erase-verify mode. Access flash memory only for verify operations (verification during programming/erasing). Do not clear the SWE bit during programming, erasing, or verifying.

Similarly, when using the RAM emulation function while a high level is being input to the FWE pin, the SWE bit must be cleared before executing a program or reading data in flash memory. However, the RAM area overlapping flash memory space can be read and written to regardless of whether the SWE bit is set or cleared.

7. Do not use interrupts while flash memory is being programmed or erased.

All interrupt requests, including NMI, should be disabled during FWE application to give priority to program/erase operations.

8. Do not perform additional programming. Erase the memory before reprogramming.

In on-board programming, perform only one programming operation on a 128-byte programming unit block. In programmer mode, also, perform only one programming operation on a 128-byte programming unit block. Further programming must only be executed after this programming unit block has been erased.

9. Before programming, check that the chip is correctly mounted in the PROM programmer.

Overcurrent damage to the device can result if the index marks on the PROM programmer socket, socket adapter, and chip are not correctly aligned.

10. Do not touch the socket adapter or chip during programming.

Touching either of these can cause contact faults and write errors.

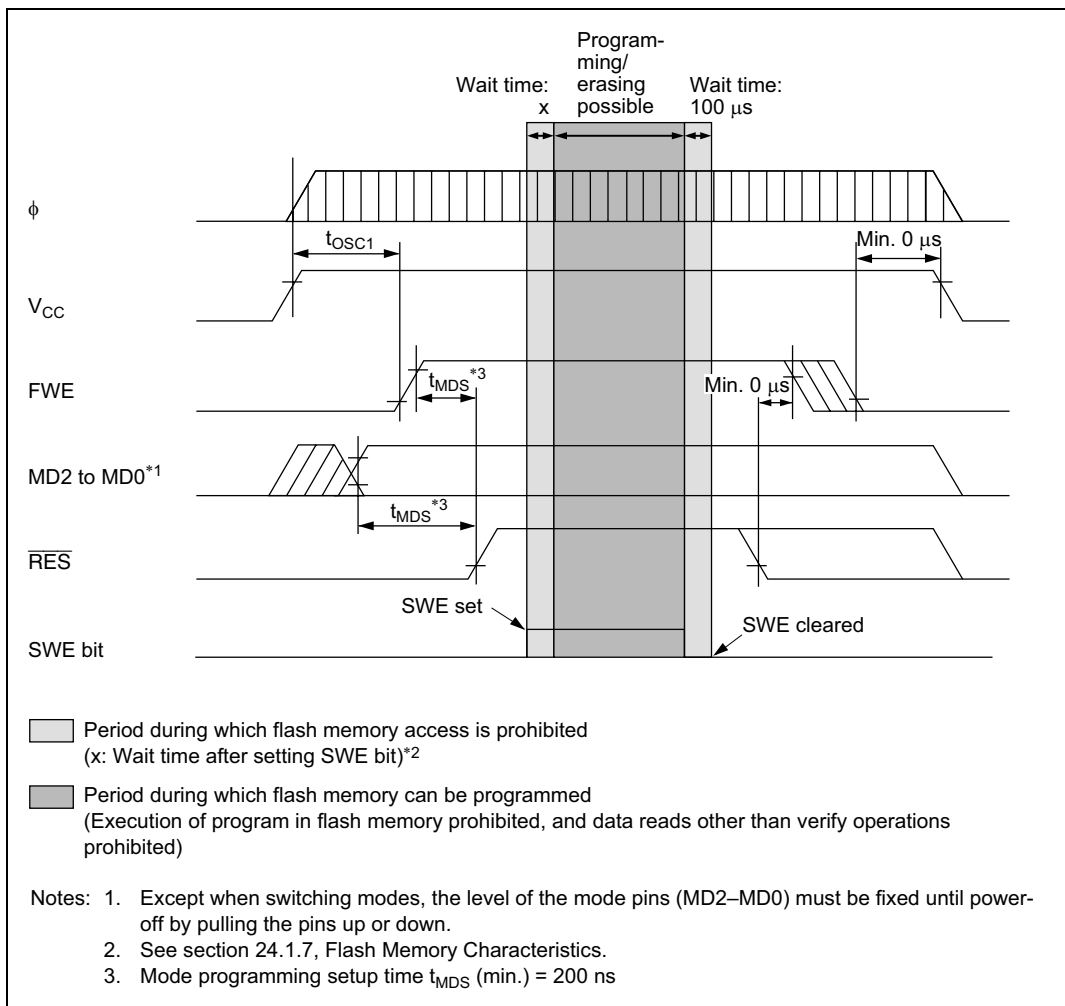

Figure 21A-26 Power-On/Off Timing (Boot Mode)

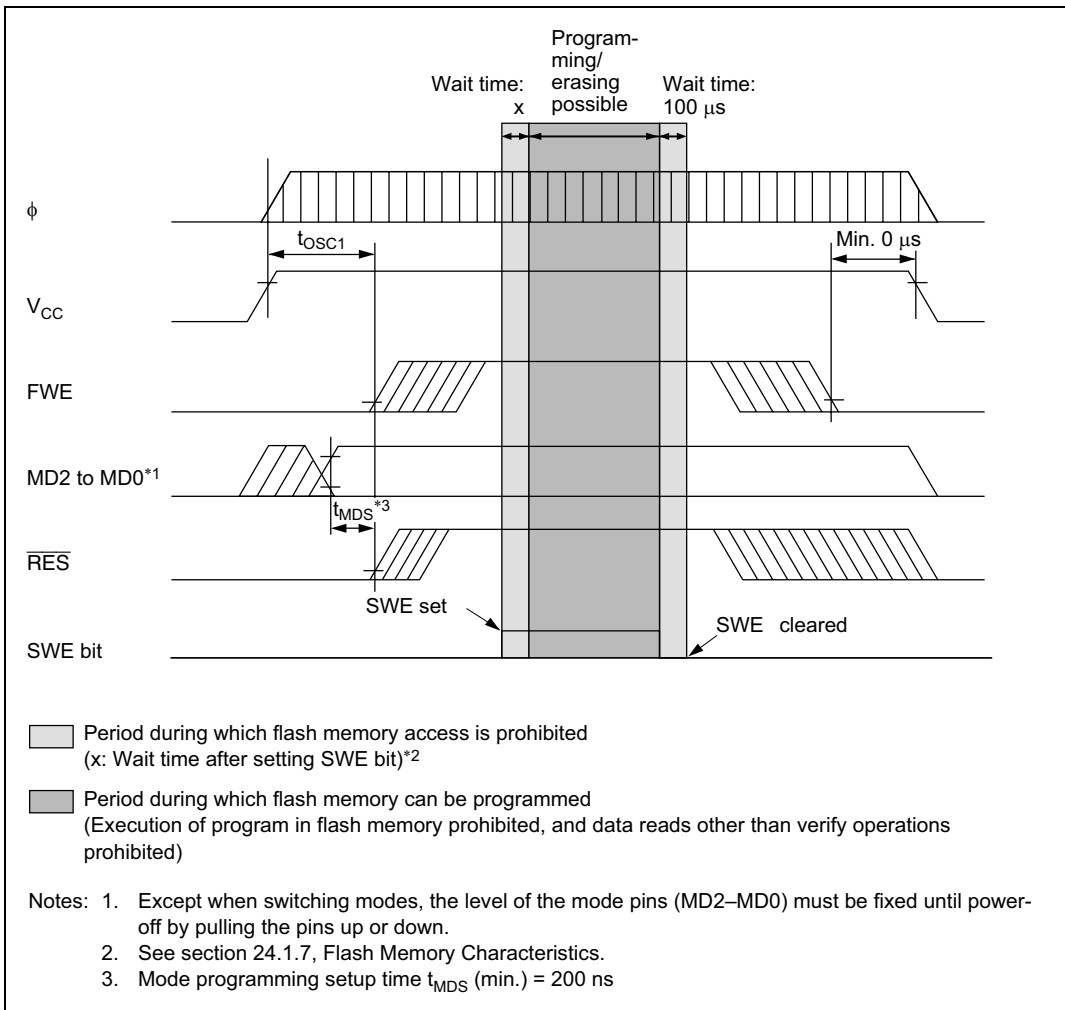

Figure 21A-27 Power-On/Off Timing (User Program Mode)

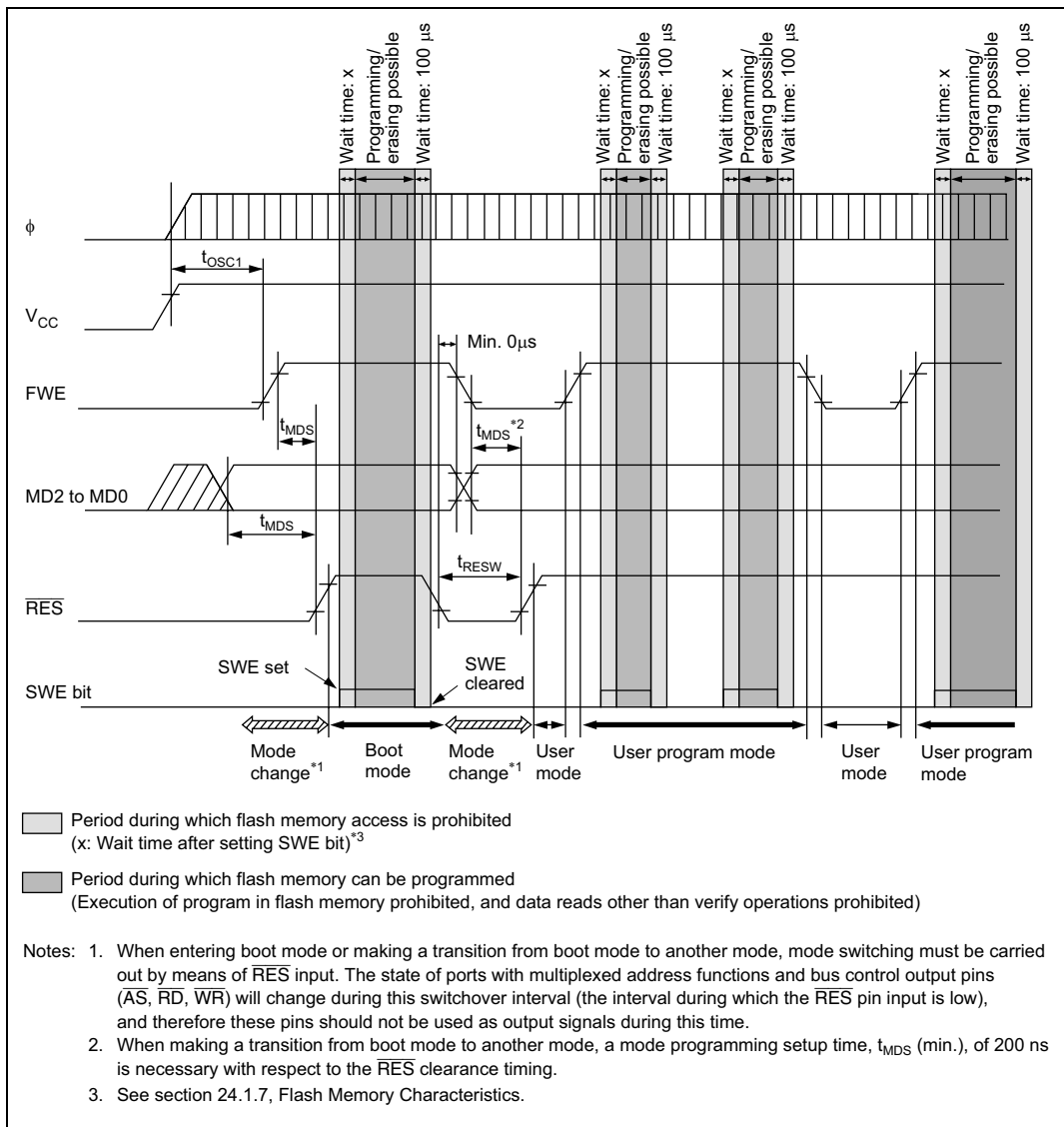

Figure 21A-28 Mode Transition Timing
(Example: Boot Mode → User Mode ↔ User Program Mode)

21A.16 Note on Switching from F-ZTAT Version to Mask ROM Version

The mask ROM version does not have the internal registers for flash memory control that are provided in the F-ZTAT version. Table 21A-27 lists the registers that are present in the F-ZTAT version but not in the mask ROM version. If a register listed in table 21A-27 is read in the mask ROM version, an undefined value will be returned. Therefore, if application software developed on the F-ZTAT version is switched to a mask ROM version product, it must be modified to ensure that the registers in table 21A-27 have no effect.

Table 21A-27 Registers Present in F-ZTAT Version but Absent in Mask ROM Version

Register	Abbreviation	Address
Flash memory control register 1	FLMCR1	H'FFA8
Flash memory control register 2	FLMCR2	H'FFA9
Erase block register 1	EBR1	H'FFAA
Erase block register 2	EBR2	H'FFAB
RAM emulation register	RAMER	H'FEDB

Section 21B ROM

(H8S/2638 Group, H8S/2639 Group, H8S/2630 Group)

21B.1 Overview

The H8S/2638 and H8S/2639 have 256 kbytes of on-chip flash memory, or 256 kbytes or 384 kbytes of on-chip mask ROM. The H8S/2630 has 384 kbytes of on-chip flash memory, or 384 kbytes of on-chip mask ROM. The ROM is connected to the bus master via a 16-bit data bus, enabling both byte and word data to be accessed in one state. Instruction fetching is thus speeded up, and processing speed increased.

The on-chip ROM is enabled and disabled by setting the mode pins (MD2 to MD0).

The flash memory version can be erased and programmed on-board, as well as with a special-purpose PROM programmer.

21B.1.1 Block Diagram

Figure 21B-1 shows a block diagram of 256-kbyte and 384-kbyte ROM.

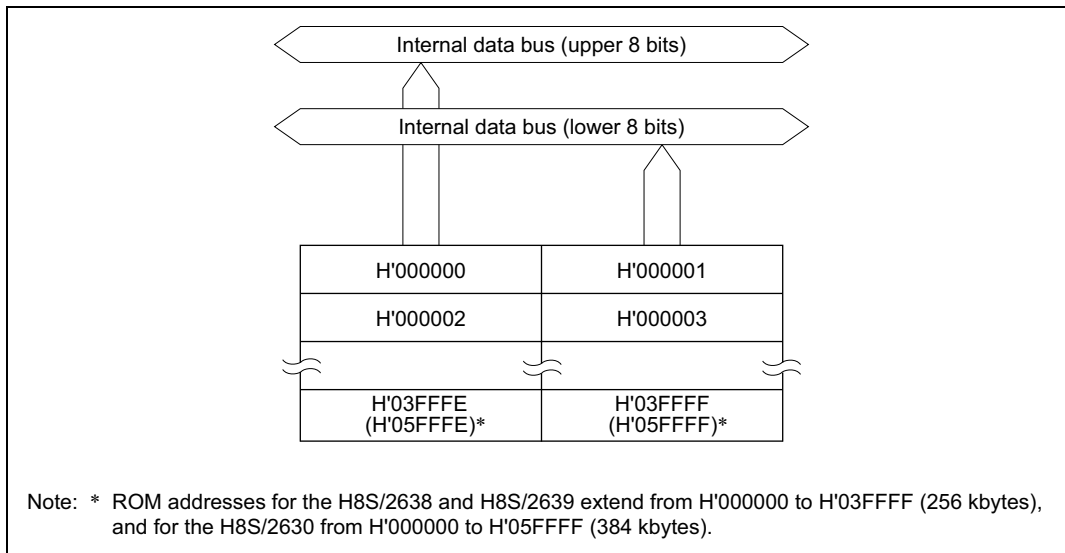

Figure 21B-1 Block Diagram of ROM 256 kbytes (384 kbytes)*

21B.1.2 Register Configuration

The H8S/2638 and H8S/2639 operating mode is controlled by the mode pins and the MDCR register. The register configuration is shown in table 21B-1.

Table 21B-1 Register Configuration

Register Name	Abbreviation	R/W	Initial Value	Address*
Mode control register	MDCR	R/W	Undefined	H'FDE7

Note: * Lower 16 bits of the address.

21B.2 Register Descriptions

21B.2.1 Mode Control Register (MDCR)

Bit:	7	6	5	4	3	2	1	0
	—	—	—	—	—	MDS2	MDS1	MDS0
Initial value:	1	0	0	0	0	—*	—*	—*
R/W:	R/W	—	—	—	—	R	R	R

Note: * Determined by pins MD2 to MD0.

MDCR is an 8-bit register used to monitor the current H8S/2638 Group, H8S/2639 Group, and H8S/2630 Group operating mode.

Bit 7—Reserved: Only 1 should be written to these bits.

Bits 6 to 3—Reserved: These bits are always read as 0 and cannot be modified.

Bits 2 to 0—Mode Select 2 to 0 (MDS2 to MDS0): These bits indicate the input levels at pins MD2 to MD0 (the current operating mode). Bits MDS2 to MDS0 correspond to pins MD2 to MD0. MDS2 to MDS0 are read-only bits, and cannot be modified. The mode pin (MD2 to MD0) input levels are latched into these bits when MDCR is read. These latches are canceled by a reset.

21B.3 Operation

The on-chip ROM is connected to the CPU by a 16-bit data bus, and both byte and word data can be accessed in one state. Even addresses are connected to the upper 8 bits, and odd addresses to the lower 8 bits. Word data must start at an even address.

The on-chip ROM is enabled and disabled by setting the mode pins (MD2, MD1, and MD0). These settings are shown in table 21B-2.

Table 21B-2 Operating Modes and ROM (F-ZTAT Version)

Operating Mode		Mode Pins				On-Chip ROM
		FWE	MD2	MD1	MD0	
Mode 0	—	0	0	0	0	—
Mode 1					1	
Mode 2				1	0	
Mode 3					1	
Mode 4	Advanced expanded mode with on-chip ROM disabled	1	0	0	0	Disabled
Mode 5	Advanced expanded mode with on-chip ROM disabled				1	
Mode 6	Advanced expanded mode with on-chip ROM enabled			1	0	Enabled (256 kbytes/ 384 kbytes)* ³
Mode 7	Advanced single-chip mode				1	Enabled (256 kbytes/ 384 kbytes)* ³
Mode 8	—	1	0	0	0	—
Mode 9					1	
Mode 10	Boot mode (advanced expanded mode with on-chip ROM enabled)* ¹			1	0	Enabled (256 kbytes/ 384 kbytes)* ³
Mode 11	Boot mode (advanced single-chip mode)* ²				1	Enabled (256 kbytes/ 384 kbytes)* ³
Mode 12	—	1	0	0	0	—
Mode 13					1	
Mode 14	User program mode (advanced expanded mode with on-chip ROM enabled)* ¹			1	0	Enabled (256 kbytes/ 384 kbytes)* ³
Mode 15	User program mode (advanced single-chip mode)* ²				1	Enabled (256 kbytes/ 384 kbytes)* ³

Notes: 1. Apart from the fact that flash memory can be erased and programmed, operation is the same as in advanced expanded mode with on-chip ROM enabled.

2. Apart from the fact that flash memory can be erased and programmed, operation is the same as in advanced single-chip mode.

3. The H8S/2638 and H8S/2639 have 256 kbytes of on-chip ROM. The H8S/2630 has 384 kbytes of on-chip ROM.

Table 21B-3 Operating Modes and ROM (Mask ROM Version)

Operating Mode	Mode Pins			On-Chip ROM	
	MD2	MD1	MD0		
Mode 0	—	0	0	—	
Mode 1			1		
Mode 2		1	0		
Mode 3			1		
Mode 4	Advanced expanded mode with on-chip ROM disabled	1	0	0	Disabled
Mode 5	Advanced expanded mode with on-chip ROM disabled			1	
Mode 6	Advanced expanded mode with on-chip ROM enabled		1	0	Enabled (256 kbytes/ 384 kbytes)*
Mode 7	Advanced single-chip mode			1	Enabled (256 kbytes/ 384 kbytes)*

Note: * The H8S/2638 and H8S/2639 have 256 kbytes of on-chip ROM. The H8S/2630 has 384 kbytes of on-chip ROM.

21B.4 Flash Memory Overview

21B.4.1 Features

The H8S/2638 and H8S/2639 have 256 kbytes of on-chip flash memory, or 256 kbytes of on-chip mask ROM. The H8S/2630 has 384 kbytes of on-chip flash memory, or 384 kbytes of on-chip mask ROM. The features of the flash memory are summarized below.

- Four flash memory operating modes
 - Program mode
 - Erase mode
 - Program-verify mode
 - Erase-verify mode
- Programming/erase methods

The flash memory is programmed 128 bytes at a time. Block erase (in single-block units) can be performed. To erase the entire flash memory, each block must be erased in turn. Block erasing can be performed as required on 4 kbytes, 32 kbytes, and 64 kbytes blocks.
- Programming/erase times

The flash memory programming time is 10 ms (typ.) for simultaneous 128-byte programming, equivalent to 80 μ s (typ.) per byte, and the erase time is 100 ms (typ.).
- Reprogramming capability

The flash memory can be reprogrammed up to 100 times.
- On-board programming modes

There are two modes in which flash memory can be programmed/erased/verified on-board:

 - Boot mode
 - User program mode
- Automatic bit rate adjustment

With data transfer in boot mode, the LSI's bit rate can be automatically adjusted to match the transfer bit rate of the host.
- Flash memory emulation in RAM

Flash memory programming can be emulated in real time by overlapping a part of RAM onto flash memory.
- Protect modes

There are three protect modes, hardware, software, and error protection, which allow protected status to be designated for flash memory program/erase/verify operations.

- Programmer mode

Flash memory can be programmed/erased in programmer mode, using a PROM programmer, as well as in on-board programming mode.

21B.4.2 Block Diagram

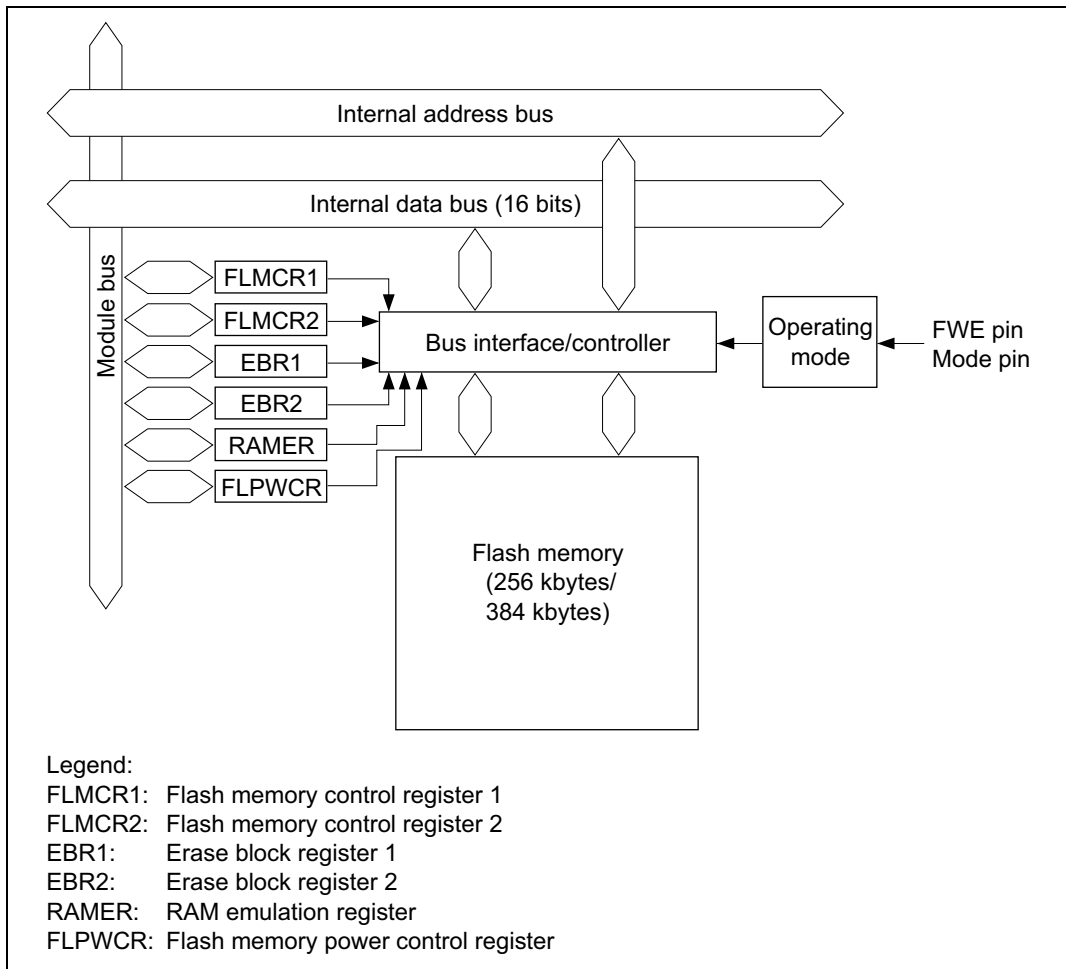

Figure 21B-2 Block Diagram of Flash Memory

21B.4.3 Mode Transitions

When the mode pins and the FWE pin are set in the reset state and a reset-start is executed, the microcomputer enters an operating mode as shown in figure 21B-3. In user mode, flash memory can be read but not programmed or erased.

The boot, user program and programmer modes are provided as modes to write and erase the flash memory.

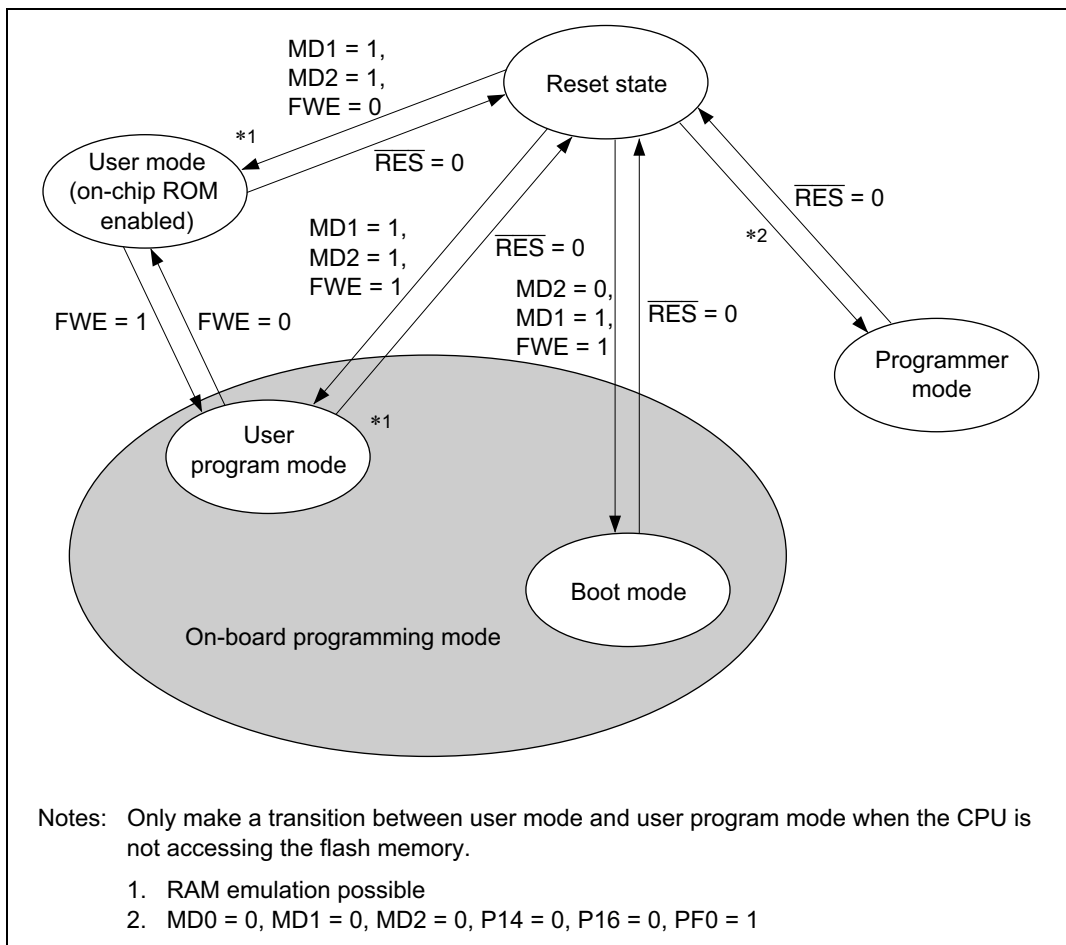

Figure 21B-3 Flash Memory State Transitions

21B.4.4 On-Board Programming Modes

Boot Mode

1. Initial state

The old program version or data remains written in the flash memory. The user should prepare the programming control program and new application program beforehand in the host.

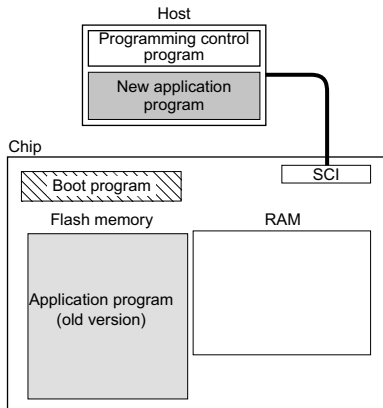

2. Programming control program transfer

When boot mode is entered, the boot program in the chip (originally incorporated in the chip) is started and the programming control program in the host is transferred to RAM via SCI communication. The boot program required for flash memory erasing is automatically transferred to the RAM boot program area.

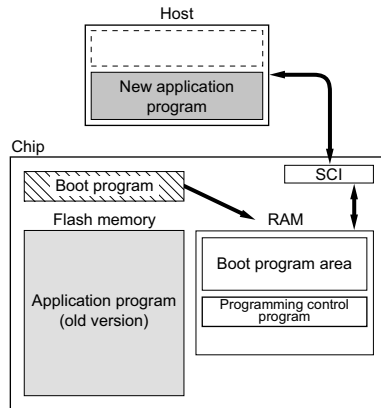

3. Flash memory initialization

The erase program in the boot program area (in RAM) is executed, and the flash memory is initialized (to H'FF). In boot mode, total flash memory erasure is performed, without regard to blocks.

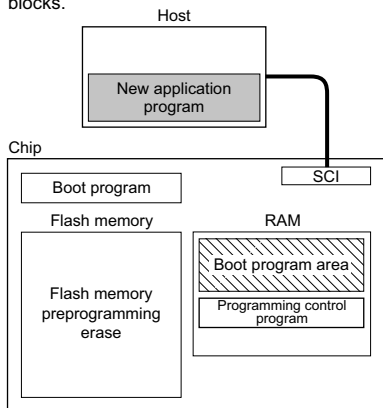

4. Writing new application program

The programming control program transferred from the host to RAM is executed, and the new application program in the host is written into the flash memory.

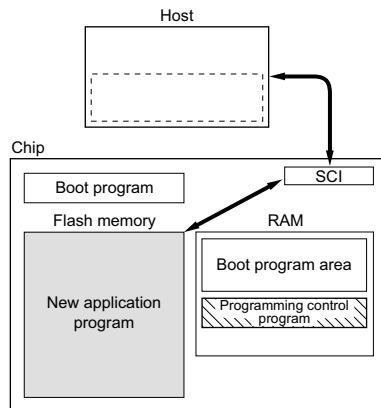

 Program execution state

User Program Mode

1. Initial state

The FWE assessment program that confirms that user program mode has been entered, and the program that will transfer the programming/erase control program from flash memory to on-chip RAM should be written into the flash memory by the user beforehand. The programming/erase control program should be prepared in the host or in the flash memory.

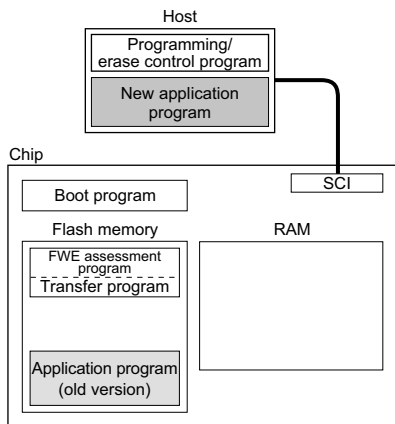

2. Programming/erase control program transfer

When user program mode is entered, user software confirms this fact, executes transfer program in the flash memory, and transfers the programming/erase control program to RAM.

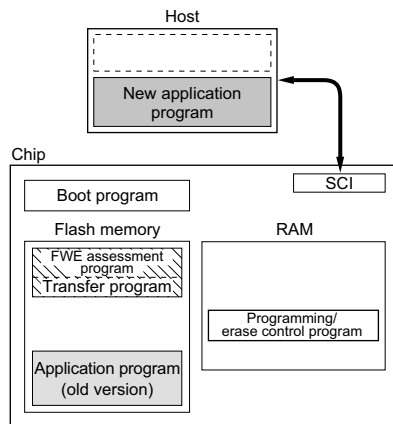

3. Flash memory initialization

The programming/erase program in RAM is executed, and the flash memory is initialized (to H'FF). Erasing can be performed in block units, but not in byte units.

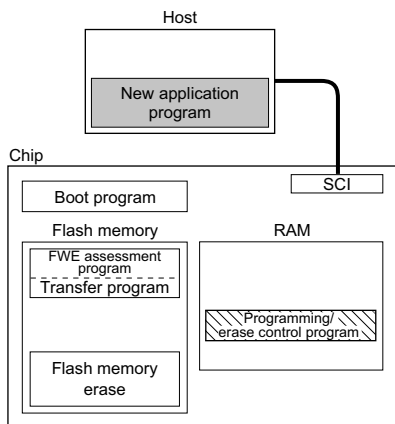

4. Writing new application program

Next, the new application program in the host is written into the erased flash memory blocks. Do not write to unerased blocks.

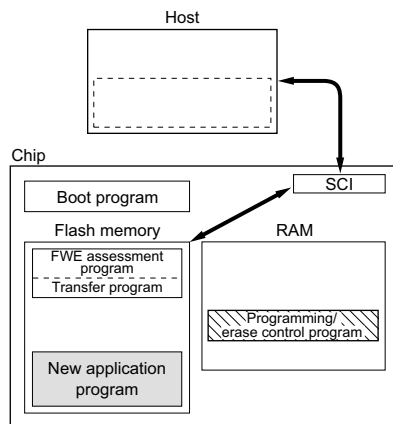

 Program execution state

21B.4.5 Flash Memory Emulation in RAM

Emulation should be performed in user mode or user program mode. When the emulation block set in RAMER is accessed while the emulation function is being executed, data written in the overlap RAM is read.

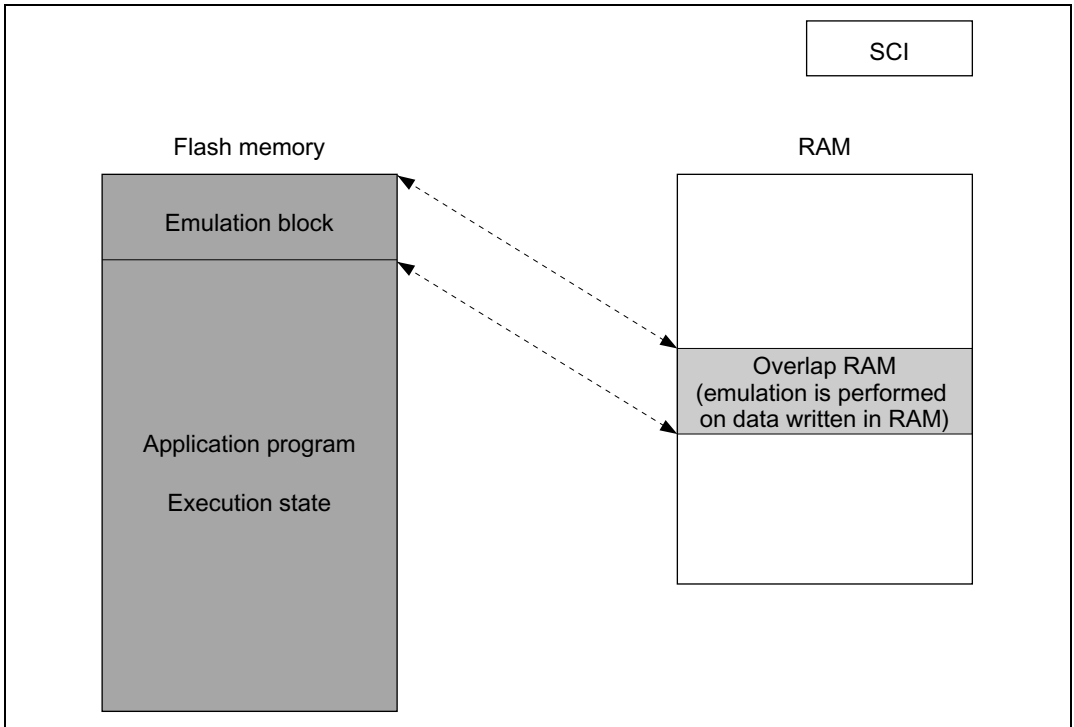

Figure 21B-4 Reading Overlap RAM Data in User Mode or User Program Mode

When overlap RAM data is confirmed, the RAMS bit is cleared, RAM overlap is released, and writes should actually be performed to the flash memory.

When the programming control program is transferred to RAM, ensure that the transfer destination and the overlap RAM do not overlap, as this will cause data in the overlap RAM to be rewritten.

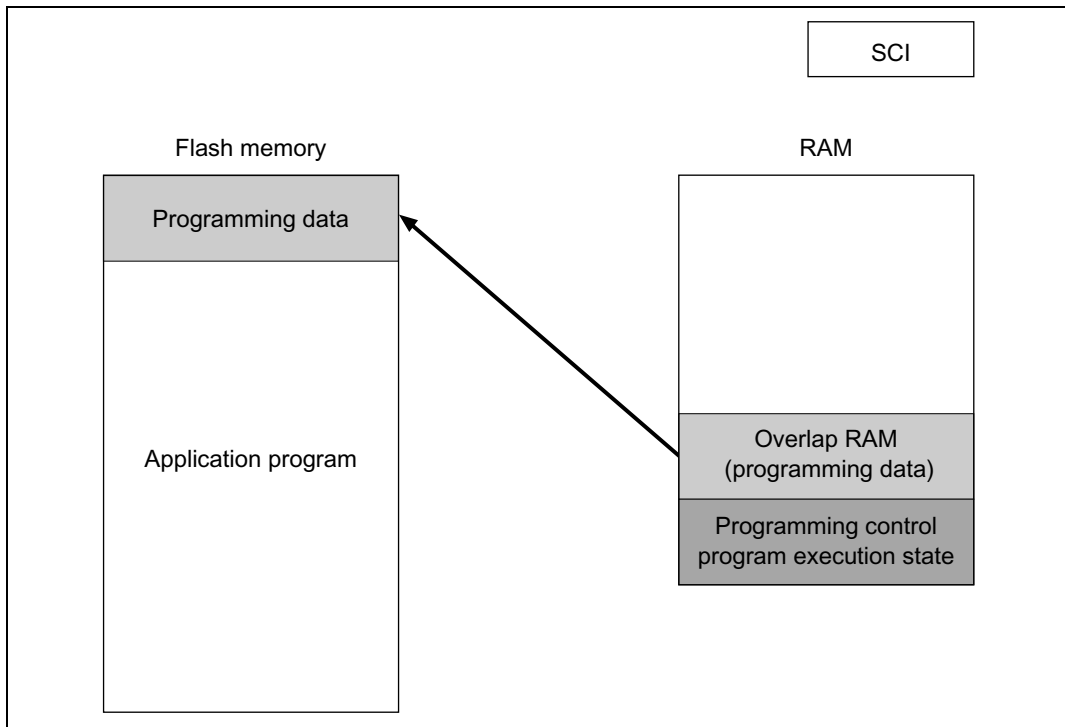

Figure 21B-5 Writing Overlap RAM Data in User Program Mode

21B.4.6 Differences between Boot Mode and User Program Mode

Table 21B-4 Differences between Boot Mode and User Program Mode

	Boot Mode	User Program Mode
Total erase	Yes	Yes
Block erase	No	Yes
Programming control program*	Program/program-verify	Erase/erase-verify Program/program-verify Emulation

Note: * To be provided by the user, in accordance with the recommended algorithm.

21B.4.7 Block Configuration

The H8S/2638 and H8S/2639 have 256 kbytes of flash memory, which is divided into three 64-kbyte blocks, one 32-kbyte block, and eight 4-kbyte blocks. The H8S/2630 has 384 kbytes of flash memory, which is divided into five 64-kbyte blocks, one 32-kbyte block, and eight 4-kbyte blocks.

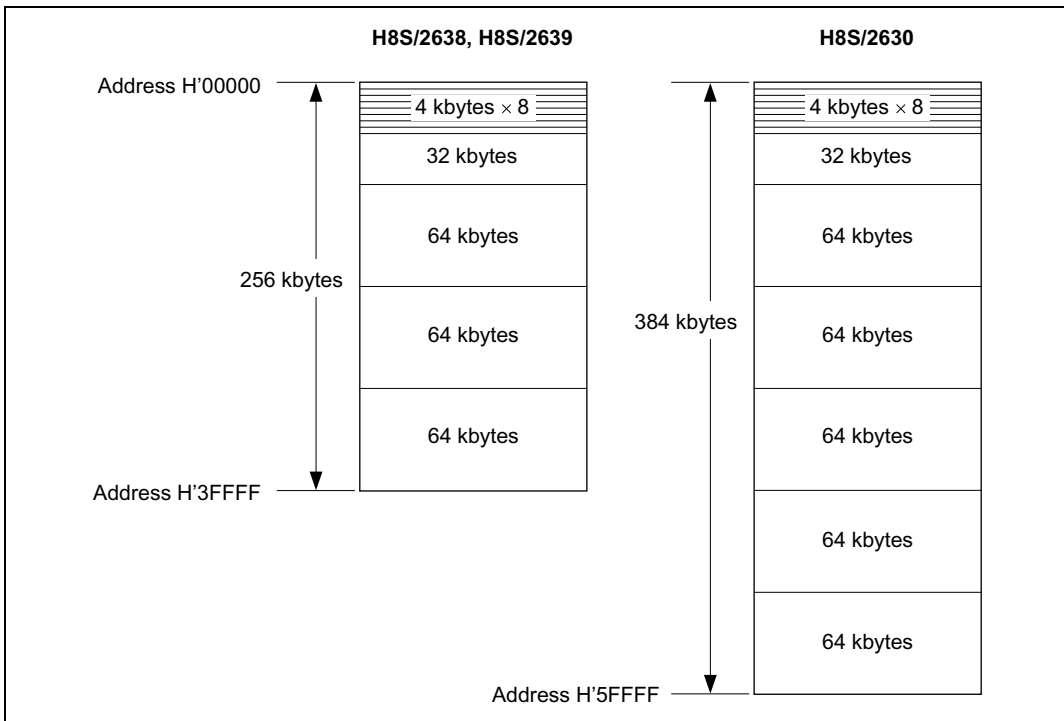

Figure 21B-6 Flash Memory Block Configuration

21B.5 Pin Configuration

The flash memory is controlled by means of the pins shown in table 21B-5.

Table 21B-5 Pin Configuration

Pin Name	Abbreviation	I/O	Function
Reset	$\overline{\text{RES}}$	Input	Reset
Flash write enable	FWE	Input	Flash memory program/erase protection by hardware
Mode 2	MD2	Input	Sets MCU operating mode
Mode 1	MD1	Input	Sets MCU operating mode
Mode 0	MD0	Input	Sets MCU operating mode
Port F0	PF0	Input	Sets MCU operating mode in programmer mode
Port 16	P16	Input	Sets MCU operating mode in programmer mode
Port 14	P14	Input	Sets MCU operating mode in programmer mode
Transmit data	TxD1	Output	Serial transmit data output
Receive data	RxD1	Input	Serial receive data input

21B.6 Register Configuration

The registers used to control the on-chip flash memory when enabled are shown in table 21B-6.

Table 21B-6 Register Configuration

Register Name	Abbreviation	R/W	Initial Value	Address ^{*1}
Flash memory control register 1	FLMCR1 ^{*4}	R/W	H'00 ^{*2}	H'FFA8
Flash memory control register 2	FLMCR2 ^{*4}	R	H'00	H'FFA9
Erase block register 1	EBR1 ^{*4}	R/W	H'00 ^{*3}	H'FFAA
Erase block register 2	EBR2 ^{*4}	R/W	H'00 ^{*3}	H'FFAB
RAM emulation register	RAMER ^{*4}	R/W	H'00	H'FEDB
Flash memory power control register	FLPWCR ^{*4}	R/W	H'00 ^{*3}	H'FFAC

Notes: 1. Lower 16 bits of the address.

2. When a high level is input to the FWE pin, the initial value is H'80.

3. When a low level is input to the FWE pin, or if a high level is input and the SWE1 bit in FLMCR1 is not set, these registers are initialized to H'00.

4. FLMCR1, FLMCR2, EBR1, and EBR2, RAMER, and FLPWCR are 8-bit registers.
Use byte access on these registers.

21B.7 Register Descriptions

21B.7.1 Flash Memory Control Register 1 (FLMCR1)

FLMCR1 is an 8-bit register used for flash memory operating mode control. Program-verify mode or erase-verify mode for on-chip flash memory is entered by setting SWE bit to 1 when FWE = 1, then setting the PV or EV bit. Program mode for on-chip flash memory is entered by setting SWE bit to 1 when FWE = 1, then setting the PSU bit, and finally setting the P bit. Erase mode for on-chip flash memory is entered by setting SWE bit to 1 when FWE = 1, then setting the ESU bit, and finally setting the E bit. FLMCR1 is initialized by a reset, and in hardware standby mode and software standby mode. Its initial value is H'80 when a high level is input to the FWE pin, and H'00 when a low level is input. When on-chip flash memory is disabled, a read will return H'00, and writes are invalid.

Writes are enabled only in the following cases: Writes to bit SWE of FLMCR1 enabled when FWE = 1, to bits ESU, PSU, EV, and PV when FWE = 1 and SWE = 1, to bit E when FWE = 1, SWE = 1 and ESU = 1, and to bit P when FWE = 1, SWE = 1, and PSU = 1.

Bit:	7	6	5	4	3	2	1	0
	FWE	SWE	ESU	PSU	EV	PV	E	P
Initial value:	—*	0	0	0	0	0	0	0
R/W:	R	R/W	R/W	R/W	R/W	R/W	R/W	R/W

Note: * Determined by the state of the FWE pin.

Bit 7—Flash Write Enable Bit (FWE): Sets hardware protection against flash memory programming/erasing.

Bit 7

FWE	Description
0	When a low level is input to the FWE pin (hardware-protected state)
1	When a high level is input to the FWE pin

Bit 6—Software Write Enable Bit (SWE): This bit selects write and erase valid/invalid of the flash memory. Set it when setting bits 5 to 0, bits 7 to 0 of EBR1, and bits 5 to 0* of EBR2.

Bit 6

SWE	Description
0	Writes disabled (Initial value)
1	Writes enabled [Setting condition] <ul style="list-style-type: none"> When FWE = 1

Note: * Bits 3 to 0 of EBR2 for the H8S/2638 and H8S/2639.

Bit 5—Erase Setup Bit (ESU): Prepares for a transition to erase mode. Set this bit to 1 before setting the E bit in FLMCR1 to 1. Do not set the SWE, PSU, EV, PV, E, or P bit at the same time.

Bit 5

ESU	Description
0	Erase setup cleared (Initial value)
1	Erase setup [Setting condition] <ul style="list-style-type: none"> When FWE = 1 and SWE = 1

Bit 4—Program Setup Bit (PSU): Prepares for a transition to program mode. Set this bit to 1 before setting the P bit in FLMCR1 to 1. Do not set the SWE, ESU, EV, PV, E, or P bit at the same time.

Bit 4

PSU	Description
0	Program setup cleared (Initial value)
1	Program setup [Setting condition] <ul style="list-style-type: none"> When FWE = 1 and SWE = 1

Bit 3—Erase-Verify (EV): Selects erase-verify mode transition or clearing. Do not set the SWE, ESU, PSU, PV, E, or P bit at the same time.

Bit 3

EV	Description
0	Erase-verify mode cleared (Initial value)
1	Transition to erase-verify mode [Setting condition] <ul style="list-style-type: none"> When FWE = 1 and SWE = 1

Bit 2—Program-Verify (PV): Selects program-verify mode transition or clearing. Do not set the SWE, ESU, PSU, EV, E, or P bit at the same time.

Bit 2

PV	Description
0	Program-verify mode cleared (Initial value)
1	Transition to program-verify mode [Setting condition] <ul style="list-style-type: none"> When FWE = 1 and SWE = 1

Bit 1—Erase (E): Selects erase mode transition or clearing. Do not set the SWE, ESU, PSU, EV, PV, or P bit at the same time.

Bit 1

E	Description
0	Erase mode cleared (Initial value)
1	Transition to erase mode [Setting condition] <ul style="list-style-type: none"> When FWE = 1, SWE = 1, and ESU = 1

Bit 0—Program (P): Selects program mode transition or clearing. Do not set the SWE, PSU, ESU, EV, PV, or E bit at the same time.

Bit 0

P	Description
0	Program mode cleared (Initial value)
1	Transition to program mode [Setting condition] <ul style="list-style-type: none"> When FWE = 1, SWE = 1, and PSU = 1

21B.7.2 Flash Memory Control Register 2 (FLMCR2)

FLMCR2 is an 8-bit register used for flash memory operating mode control. FLMCR2 is initialized to H'00 by a reset, and in hardware standby mode and software standby mode. When on-chip flash memory is disabled, a read will return H'00.

Bit:	7	6	5	4	3	2	1	0
	FLER	—	—	—	—	—	—	—
Initial value:	0	0	0	0	0	0	0	0
R/W:	R	—	—	—	—	—	—	—

Note: FLMCR2 is a read-only register, and should not be written to.

Bit 7—Flash Memory Error (FLER): Indicates that an error has occurred during an operation on flash memory (programming or erasing). When FLER is set to 1, flash memory goes to the error-protection state.

Bit 7

FLER	Description
0	Flash memory is operating normally (Initial value) Flash memory program/erase protection (error protection) is disabled [Clearing condition] <ul style="list-style-type: none"> Reset or hardware standby mode
1	An error has occurred during flash memory programming/erasing Flash memory program/erase protection (error protection) is enabled [Setting condition] <ul style="list-style-type: none"> See section 21B.10.3, Error Protection

Bits 6 to 0—Reserved: These bits always read 0.

21B.7.3 Erase Block Register 1 (EBR1)

EBR1 is an 8-bit register that specifies the flash memory erase area block by block. EBR1 is initialized to H'00 by a reset, in hardware standby mode and software standby mode, when a low level is input to the FWE pin, and when a high level is input to the FWE pin and the SWE bit in FLMCR1 is not set. When a bit in EBR1 is set to 1, the corresponding block can be erased. Other blocks are erase-protected. Only one of the bits of EBR1 and EBR2 combined can be set. Do not set more than one bit, as this will cause all the bits in both EBR1 and EBR2 to be automatically cleared to 0. When on-chip flash memory is disabled, a read will return H'00, and writes are invalid.

The flash memory erase block configuration is shown in table 21B-7.

Bit:	7	6	5	4	3	2	1	0
	EB7	EB6	EB5	EB4	EB3	EB2	EB1	EB0
Initial value:	0	0	0	0	0	0	0	0
R/W:	R/W	R/W	R/W	R/W	R/W	R/W	R/W	R/W

21B.7.4 Erase Block Register 2 (EBR2)

EBR2 is an 8-bit register that specifies the flash memory erase area block by block. EBR2 is initialized to H'00 by a reset, in hardware standby mode and software standby mode, when a low level is input to the FWE pin. Bit 0 will be initialized to 0 if bit SWE of FLMCR1 is not set, even though a high level is input to pin FWE. When a bit in EBR2 is set to 1, the corresponding block can be erased. Other blocks are erase-protected. Only one of the bits of EBR1 and EBR2 combined can be set. Do not set more than one bit, as this will cause all the bits in both EBR1 and EBR2 to be automatically cleared to 0. On the H8S/2638 and H8S/2639 bits 7 to 4 are reserved, and on the H8S/2630 bits 7 and 6 are reserved. Only 0 may be written to these reserved bits. When on-chip flash memory is disabled, a read will return H'00, and writes are invalid.

The flash memory erase block configuration is shown in table 21B-7.

Bit:	7	6	5	4	3	2	1	0
	—	—	EB13*	EB12*	EB11	EB10	EB9	EB8
Initial value:	0	0	0	0	0	0	0	0
R/W:	R/W	R/W	R/W	R/W	R/W	R/W	R/W	R/W

Note: * Valid on the H8S/2630. On the H8S/2638 and H8S/2639 these bits are reserved and only 0 may be written to them.

Table 21B-7 Flash Memory Erase Blocks

Block (Size)	Addresses
EB0 (4 kbytes)	H'000000 to H'000FFF
EB1 (4 kbytes)	H'001000 to H'001FFF
EB2 (4 kbytes)	H'002000 to H'002FFF
EB3 (4 kbytes)	H'003000 to H'003FFF
EB4 (4 kbytes)	H'004000 to H'004FFF
EB5 (4 kbytes)	H'005000 to H'005FFF
EB6 (4 kbytes)	H'006000 to H'006FFF
EB7 (4 kbytes)	H'007000 to H'007FFF
EB8 (32 kbytes)	H'008000 to H'00FFFF
EB9 (64 kbytes)	H'010000 to H'01FFFF
EB10 (64 kbytes)	H'020000 to H'02FFFF
EB11 (64 kbytes)	H'030000 to H'03FFFF
EB12 (64 kbytes)*	H'040000 to H'04FFFF
EB13 (64 kbytes)*	H'050000 to H'05FFFF

Note: * This function is not available in the H8S/2638 and H8S/2639.

21B.7.5 RAM Emulation Register (RAMER)

RAMER specifies the area of flash memory to be overlapped with part of RAM when emulating real-time flash memory programming. RAMER initialized to H'00 by a reset and in hardware standby mode. It is not initialized in software standby mode. RAMER settings should be made in user mode or user program mode.

Flash memory area divisions are shown in table 21B-8. To ensure correct operation of the emulation function, the ROM for which RAM emulation is performed should not be accessed immediately after this register has been modified. Normal execution of an access immediately after register modification is not guaranteed.

Bit:	7	6	5	4	3	2	1	0
	—	—	—	—	RAMS	RAM2	RAM1	RAM0
Initial value:	0	0	0	0	0	0	0	0
R/W:	R	R	R/W	R/W	R/W	R/W	R/W	R/W

Bits 7 and 6—Reserved: These bits always read 0.

Bits 5 and 4—Reserved: Only 0 may be written to these bits.

Bit 3—RAM Select (RAMS): Specifies selection or non-selection of flash memory emulation in RAM. When RAMS = 1, all flash memory block are program/erase-protected.

Bit 3

RAMS	Description
0	Emulation not selected (Initial value) Program/erase-protection of all flash memory blocks is disabled
1	Emulation selected Program/erase-protection of all flash memory blocks is enabled

Bits 2 to 0—Flash Memory Area Selection: These bits are used together with bit 3 to select the flash memory area to be overlapped with RAM. (See table 21B-8.)

Table 21B-8 Flash Memory Area Divisions

Addresses	Block Name	RAMS	RAM1	RAM1	RAM0
H'FFD000 to H'FFDFFF	RAM area 4 kbytes	0	*	*	*
H'000000 to H'000FFF	EB0 (4 kbytes)	1	0	0	0
H'001000 to H'001FFF	EB1 (4 kbytes)	1	0	0	1
H'002000 to H'002FFF	EB2 (4 kbytes)	1	0	1	0
H'003000 to H'003FFF	EB3 (4 kbytes)	1	0	1	1
H'004000 to H'004FFF	EB4 (4 kbytes)	1	1	0	0
H'005000 to H'005FFF	EB5 (4 kbytes)	1	1	0	1
H'006000 to H'006FFF	EB6 (4 kbytes)	1	1	1	0
H'007000 to H'007FFF	EB7 (4 kbytes)	1	1	1	1

*: Don't care

21B.7.6 Flash Memory Power Control Register (FLPWCR)

Bit:	7	6	5	4	3	2	1	0
	PDWND	—	—	—	—	—	—	—
Initial value:	0	0	0	0	0	0	0	0
R/W:	R/W	R	R	R	R	R	R	R

FLPWCR enables or disables a transition to the flash memory power-down mode when the LSI switches to subactive mode*.

Note: * Subclock functions (subactive mode, subsleep mode, and watch mode) are not available in versions other than the U-mask and W-mask versions.

Bit 7—Power-Down Disable (PDWND): The subactive mode is not available in versions other than the U-mask and W-mask versions.

Only 0 should be written to this bit in the case of versions other than the U-mask and W-mask versions.

See section 21.B.14, Flash Memory and Power-Down States, for more information.

Bit 7

PDWND	Description
0	Transition to flash memory power-down mode enabled (Initial value)
1	Transition to flash memory power-down mode disabled

Bits 6 to 0—Reserved: These bits always read 0.

21B.8 On-Board Programming Modes

When pins are set to on-board programming mode and a reset-start is executed, a transition is made to the on-board programming state in which program/erase/verify operations can be performed on the on-chip flash memory. There are two on-board programming modes: boot mode and user program mode. The pin settings for transition to each of these modes are shown in table 21B-9. For a diagram of the transitions to the various flash memory modes, see figure 21B-3.

Table 21B-9 Setting On-Board Programming Modes

Mode		FWE	MD2	MD1	MD0
Boot mode	Expanded mode	1	0	1	0
	Single-chip mode		0	1	1
User program mode	Expanded mode	1	1	1	0
	Single-chip mode		1	1	1

21B.8.1 Boot Mode

When boot mode is used, the flash memory programming control program must be prepared in the host beforehand. The SCI channel to be used is set to asynchronous mode.

When a reset-start is executed after the H8S/2638', H8S/2639', and H8S/2630' pins have been set to boot mode, the boot program built into the H8S/2638, H8S/2639, and H8S/2630 are started and the programming control program prepared in the host is serially transmitted to the H8S/2638, H8S/2639, and H8S/2630 via the SCI. In the H8S/2638, H8S/2639, and H8S/2630, the programming control program received via the SCI is written into the programming control program area in on-chip RAM. After the transfer is completed, control branches to the start address of the programming control program area and the programming control program execution state is entered (flash memory programming is performed).

The transferred programming control program must therefore include coding that follows the programming algorithm given later.

The system configuration in boot mode is shown in figure 21B-7, and the boot mode execution procedure in figure 21B-8.

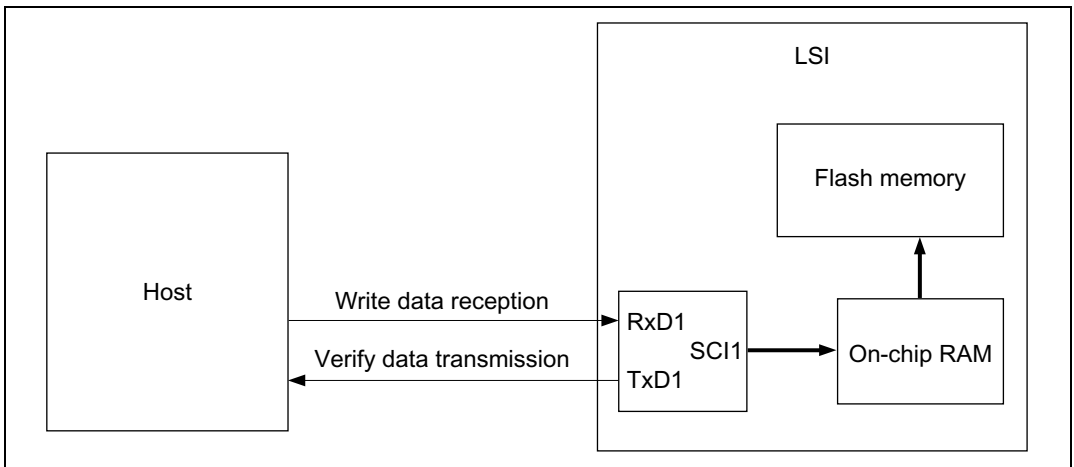

Figure 21B-7 System Configuration in Boot Mode

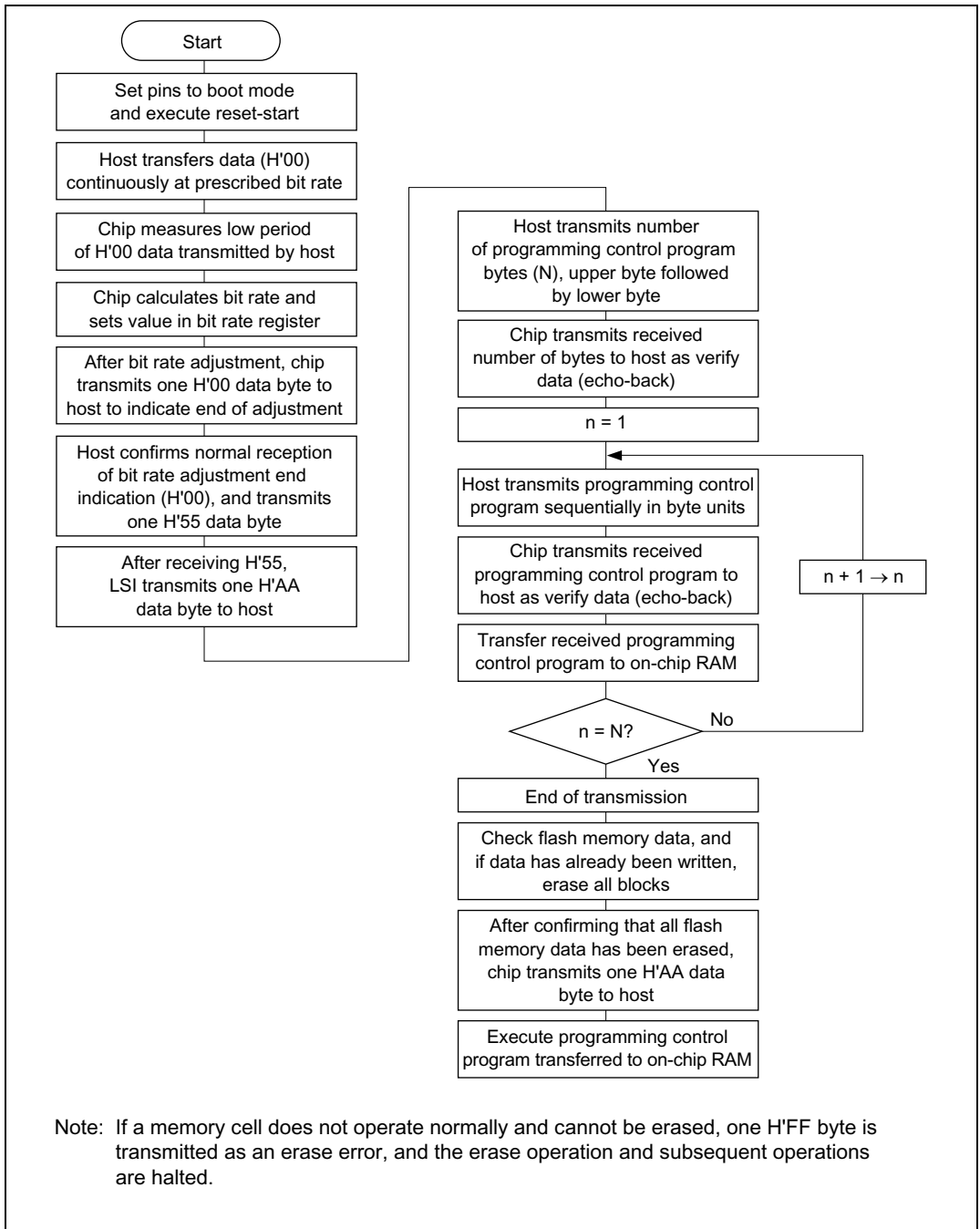
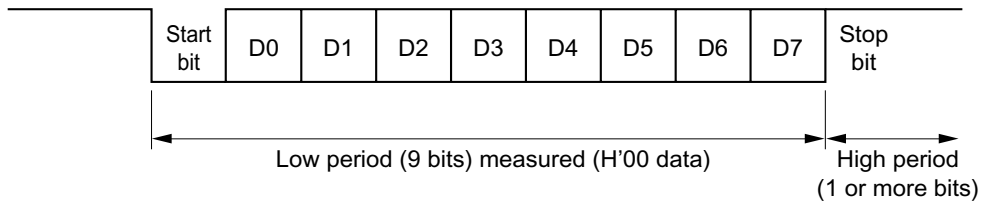

Figure 21B-8 Boot Mode Execution Procedure

Automatic SCI Bit Rate Adjustment



When boot mode is initiated, the LSI measures the low period of the asynchronous SCI communication data (H'00) transmitted continuously from the host. The SCI transmit/receive format should be set as follows: 8-bit data, 1 stop bit, no parity. The LSI calculates the bit rate of the transmission from the host from the measured low period, and transmits one H'00 byte to the host to indicate the end of bit rate adjustment. The host should confirm that this adjustment end indication (H'00) has been received normally, and transmit one H'55 byte to the LSI. If reception cannot be performed normally, initiate boot mode again (reset), and repeat the above operations. Depending on the host's transmission bit rate and the LSI's system clock frequency, there will be a discrepancy between the bit rates of the host and the LSI. Set the host transfer bit rate at 4,800, 9,600 or 19,200 bps to operate the SCI properly.

Table 21B-10 shows host transfer bit rates and system clock frequencies for which automatic adjustment of the LSI bit rate is possible. The boot program should be executed within this system clock range.

Table 21B-10 System Clock Frequencies for which Automatic Adjustment of LSI Bit Rate Is Possible

Host Bit Rate	System Clock Frequency for which Automatic Adjustment of LSI Bit Rate Is Possible
4,800 bps	4 to 20 MHz
9,600 bps	8 to 20 MHz
19,200 bps	16 to 20 MHz

Note: The system clock frequency used in boot mode is generated by an external crystal oscillator element. PLL frequency multiplication is not used.

On-Chip RAM Area Divisions in Boot Mode: In boot mode, the RAM area is divided into an area used by the boot program and an area to which the programming control program is transferred via the SCI, as shown in figure 21B-9. The boot program area cannot be used until the execution state in boot mode switches to the programming control program transferred from the host.

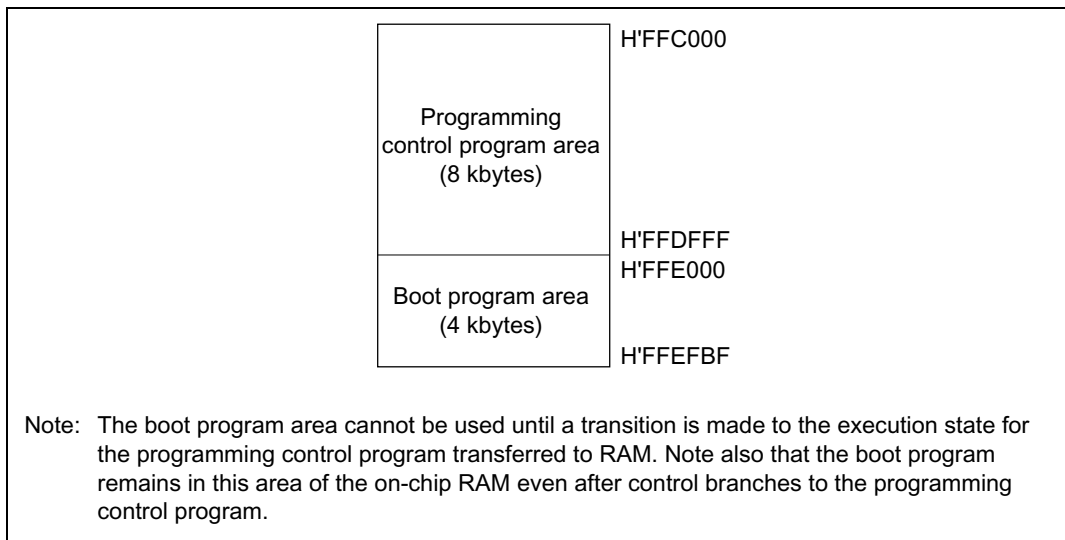

Figure 21B-9 RAM Areas in Boot Mode

Notes on Use of Boot Mode:

- When the chip comes out of reset in boot mode, it measures the low-level period of the input at the SCI's RxD1 pin. The reset should end with RxD1 high. After the reset ends, it takes approximately 100 states before the chip is ready to measure the low-level period of the RxD1 pin.
- In boot mode, if any data has been programmed into the flash memory (if all data is not 1), all flash memory blocks are erased. Boot mode is for use when user program mode is unavailable, such as the first time on-board programming is performed, or if the program activated in user program mode is accidentally erased.
- Interrupts cannot be used while the flash memory is being programmed or erased.
- The RxD1 and TxD1 pins should be pulled up on the board.
- Before branching to the programming control program (RAM area H'FFC000), the chip terminates transmit and receive operations by the on-chip SCI (channel 1) (by clearing the RE

and TE bits in SCR to 0), but the adjusted bit rate value remains set in BRR. The transmit data output pin, TxD1, goes to the high-level output state ($P33DDR = 1$, $P33DR = 1$).

The contents of the CPU's internal general registers are undefined at this time, so these registers must be initialized immediately after branching to the programming control program. In particular, since the stack pointer (SP) is used implicitly in subroutine calls, etc., a stack area must be specified for use by the programming control program.

The initial values of other on-chip registers are not changed.

- Boot mode can be entered by making the pin settings shown in table 21B-9 and executing a reset-start.

Boot mode can be cleared by driving the reset pin low, waiting at least 20 states, then setting the FWE pin and mode pins, and executing reset release^{*1}. Boot mode can also be cleared by a WDT overflow reset.

Do not change the mode pin input levels in boot mode, and do not drive the FWE pin low while the boot program is being executed or while flash memory is being programmed or erased^{*2}.

- If the mode pin input levels are changed (for example, from low to high) during a reset, the state of ports with multiplexed address functions and bus control output pins (\overline{AS} , \overline{RD} , \overline{HWR}) will change according to the change in the microcomputer's operating mode^{*3}.

Therefore, care must be taken to make pin settings to prevent these pins from becoming output signal pins during a reset, or to prevent collision with signals outside the microcomputer.

- Notes:
1. Mode pin and FWE pin input must satisfy the mode programming setup time ($t_{MDS} = 4$ states) with respect to the reset release timing.
 2. For precautions on applying and disconnecting FWE, see section 21B.15, Flash Memory Programming and Erasing Precautions.
 3. See Appendix D, Pin States.

21B.8.2 User Program Mode

When set to user program mode, the chip can program and erase its flash memory by executing a user program/erase control program. Therefore, on-board reprogramming of the on-chip flash memory can be carried out by providing on-board means of FWE control and supply of programming data, and storing a program/erase control program in part of the program area as necessary.

To select user program mode, select a mode that enables the on-chip flash memory (mode 6 or 7), and apply a high level to the FWE pin. In this mode, on-chip supporting modules other than flash memory operate as they normally would in modes 6 and 7.

The flash memory itself cannot be read while the SWE bit is set to 1 to perform programming or erasing, so the control program that performs programming and erasing should be run in on-chip RAM or external memory. If the program is to be located in external memory, the instruction for writing to flash memory, and the following instruction, should be placed in on-chip RAM.

Figure 21B-10 shows the procedure for executing the program/erase control program when transferred to on-chip RAM.

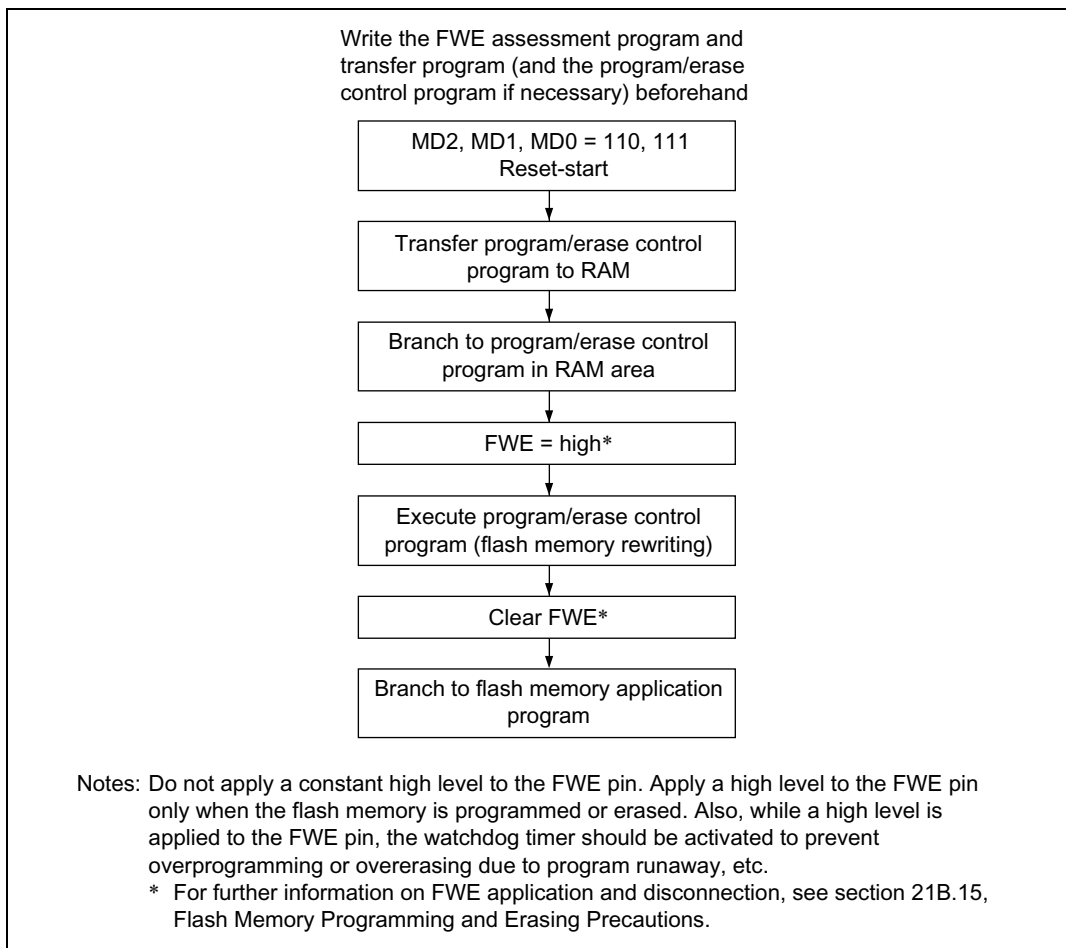

Figure 21B-10 User Program Mode Execution Procedure

21B.9 Programming/Erasing Flash Memory

A software method, using the CPU, is employed to program and erase flash memory in the on-board programming modes. There are four flash memory operating modes: program mode, erase mode, program-verify mode, and erase-verify mode. Transitions to these modes are made by setting the PSU, ESU, P, E, PV, and EV bits in FLMCR1 for on-chip flash memory.

The flash memory cannot be read while it is being written or erased. The flash memory cannot be read while being programmed or erased. Therefore, the program (user program) that controls flash memory programming/erasing should be located and executed in on-chip RAM or external memory. If the program is to be located in external memory, the instruction for writing to flash memory, and the following instruction, should be placed in on-chip RAM. Also ensure that the DTC is not activated before or after execution of the flash memory write instruction.

In the following operation descriptions, wait times after setting or clearing individual bits in FLMCR1 are given as parameters; for details of the wait times, see section 24.2.7 and 24.3.7, Flash Memory Characteristics.

- Notes:
1. Operation is not guaranteed if bits SWE, ESU, PSU, EV, PV, E, and P of FLMCR1 are set/reset by a program in flash memory in the corresponding address areas.
 2. When programming or erasing, set FWE to 1 (programming/erasing will not be executed if FWE = 0).
 3. Programming should be performed in the erased state. Do not perform additional programming on previously programmed addresses.

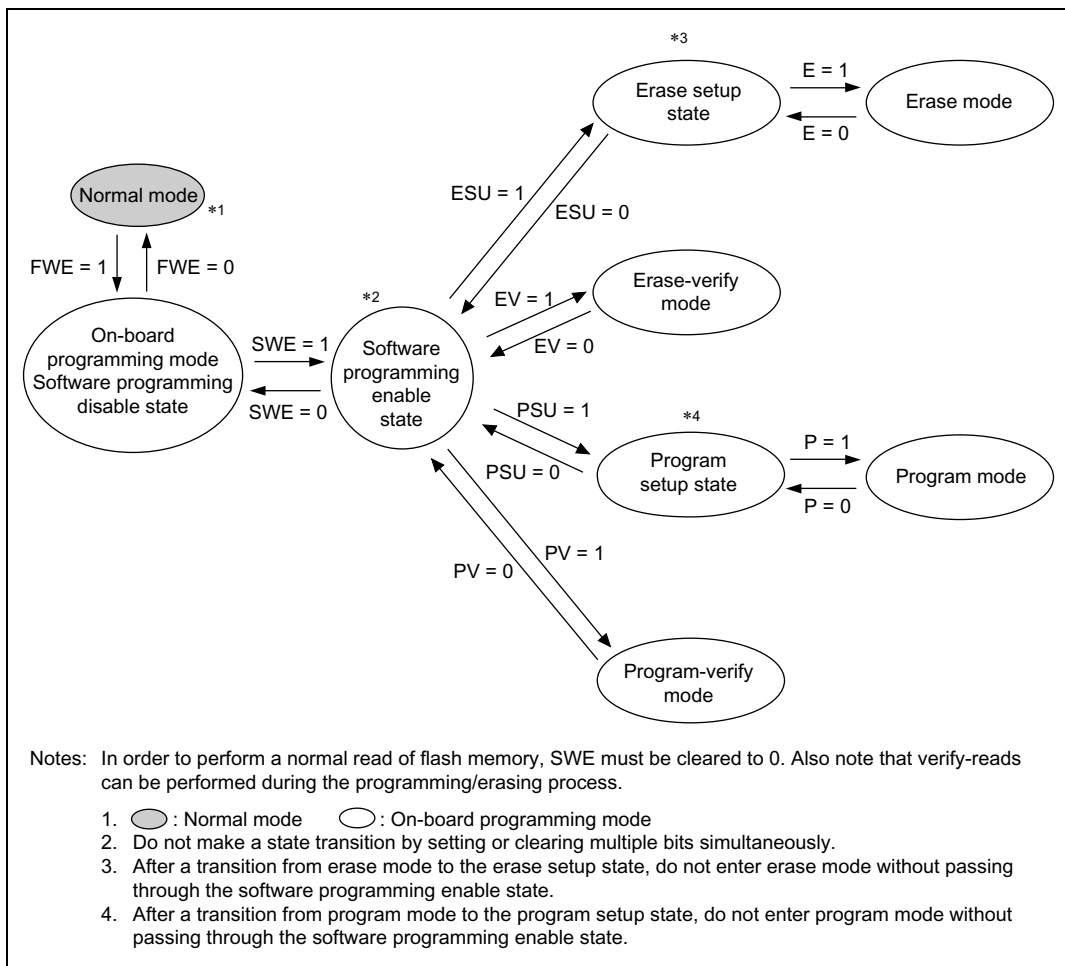

Figure 21B-11 FLMCR1 Bit Settings and State Transitions

21B.9.1 Program Mode

When writing data or programs to flash memory, the program/program-verify flowchart shown in figure 21B-12 should be followed. Performing programming operations according to this flowchart will enable data or programs to be written to flash memory without subjecting the device to voltage stress or sacrificing program data reliability. Programming should be carried out 128 bytes at a time.

The wait times after bits are set or cleared in the flash memory control register 1 (FLMCR1) and the maximum number of programming operations (N) are shown in table 24-22 in section 24.2.7, and in table 24-34 in section 24.3.7, and in table 24-46 in section 24.4.7, Flash Memory Characteristics.

Following the elapse of (t_{sswe}) μ s or more after the SWE bit is set to 1 in FLMCR1, 128-byte data is written consecutively to the write addresses. The lower 8 bits of the first address written to must be H'00 and H'80, 128 consecutive byte data transfers are performed. The program address and program data are latched in the flash memory. A 128-byte data transfer must be performed even if writing fewer than 128 bytes; in this case, H'FF data must be written to the extra addresses.

Next, the watchdog timer (WDT) is set to prevent overprogramming due to program runaway, etc. Set a value greater than ($t_{spsu} + t_{sp} + t_{cp} + t_{cpsu}$) μ s as the WDT overflow period. Preparation for entering program mode (program setup) is performed next by setting the PSU bit in FLMCR1. The operating mode is then switched to program mode by setting the P bit in FLMCR1 after the elapse of at least (t_{spsu}) μ s. The time during which the P bit is set is the flash memory programming time. Make a program setting so that the time for one programming operation is within the range of (t_{sp}) μ s.

The wait time after P bit setting must be changed according to the degree of progress through the programming operation. For details see “Notes on Program/Program-Verify Procedure.”

21B.9.2 Program-Verify Mode

In program-verify mode, the data written in program mode is read to check whether it has been correctly written in the flash memory.

After the elapse of the given programming time, clear the P bit in FLMCR1, then wait for at least (t_{cp}) μ s before clearing the PSU bit to exit program mode. After exiting program mode, the watchdog timer setting is also cleared. The operating mode is then switched to program-verify mode by setting the PV bit in FLMCR1. Before reading in program-verify mode, a dummy write of H'FF data should be made to the addresses to be read. The dummy write should be executed after the elapse of (t_{spv}) μ s or more. When the flash memory is read in this state (verify data is read in 16-bit units), the data at the latched address is read. Wait at least (t_{spvr}) μ s after the dummy write before performing this read operation. Next, the originally written data is compared with the verify data, and reprogram data is computed (see figure 21B-12) and transferred to RAM. After verification of 128 bytes of data has been completed, exit program-verify mode, wait for at least (t_{cpv}) μ s, then clear the SWE bit in FLMCR1. If reprogramming is necessary, set program mode again, and repeat the program/program-verify sequence as before. The maximum number of repetitions of the program/program-verify sequence is indicated by the maximum programming count (N). Leave a wait time of at least (t_{cswe}) μ s after clearing SWE.

Notes on Program/Program-Verify Procedure

1. In order to perform 128-byte-unit programming, the lower 8 bits of the write start address must be H'00 or H'80.
2. When performing continuous writing of 128-byte data to flash memory, byte-unit transfer should be used.
128-byte data transfer is necessary even when writing fewer than 128 bytes of data. Write H'FF data to the extra addresses.
3. Verify data is read in word units.
4. The write pulse is applied and a flash memory write executed while the P bit in FLMCR1 is set. In the chip, write pulses should be applied as follows in the program/program-verify procedure to prevent voltage stress on the device and loss of write data reliability.
 - a. After write pulse application, perform a verify-read in program-verify mode and apply a write pulse again for any bits read as 1 (reprogramming processing). When all the 0-write bits in the 128-byte write data are read as 0 in the verify-read operation, the program/program-verify procedure is completed. In the chip, the number of loops in reprogramming processing is guaranteed not to exceed the maximum value of the maximum programming count (N).

- b. After write pulse application, a verify-read is performed in program-verify mode, and programming is judged to have been completed for bits read as 0. The following processing is necessary for programmed bits.

When programming is completed at an early stage in the program/program-verify procedure:

If programming is completed in the 1st to 6th reprogramming processing loop, additional programming should be performed on the relevant bits. Additional programming should only be performed on bits which first return 0 in a verify-read in certain reprogramming processing.

When programming is completed at a late stage in the program/program-verify procedure:

If programming is completed in the 7th or later reprogramming processing loop, additional programming is not necessary for the relevant bits.

- c. If programming of other bits is incomplete in the 128 bytes, reprogramming processing should be executed. If a bit for which programming has been judged to be completed is read as 1 in a subsequent verify-read, a write pulse should again be applied to that bit.
5. The period for which the P bit in FLMCR1 is set (the write pulse width) should be changed according to the degree of progress through the program/program-verify procedure. For detailed wait time specifications, see section 24.2.7, 24.3.7, and 24.4.7, Flash Memory Characteristics.

Item	Symbol	Item	Symbol
Wait time after P bit setting	t_{sp}	When reprogramming loop count (n) is 1 to 6	t_{sp30}
		When reprogramming loop count (n) is 7 or more	t_{sp200}
		In case of additional programming processing*	t_{sp10}

Note: * Additional programming processing is necessary only when the reprogramming loop count (n) is 1 to 6.

6. The program/program-verify flowchart for the H8S/2638, H8S/2639, and H8S/2630 are shown in figure 21B-12.

To cover the points noted above, bits on which reprogramming processing is to be executed, and bits on which additional programming is to be executed, must be determined as shown below.

Since reprogram data and additional-programming data vary according to the progress of the programming procedure, it is recommended that the following data storage areas (128 bytes each) be provided in RAM.

Reprogram Data Computation Table

(D)	Result of Verify-Read after Write Pulse Application (V)	(X) Result of Operation	Comments
0	0	1	Programming completed: reprogramming processing not to be executed
0	1	0	Programming incomplete: reprogramming processing to be executed
1	0	1	—
1	1	1	Still in erased state: no action

Legend:

(D): Source data of bits on which programming is executed

(X): Source data of bits on which reprogramming is executed

Additional-Programming Data Computation Table

(X')	Result of Verify-Read after Write Pulse Application (V)	(Y) Result of Operation	Comments
0	0	0	Programming by write pulse application judged to be completed: additional programming processing to be executed
0	1	1	Programming by write pulse application incomplete: additional programming processing not to be executed
1	0	1	Programming already completed: additional programming processing not to be executed
1	1	1	Still in erased state: no action

Legend:

(Y): Data of bits on which additional programming is executed

(X'): Data of bits on which reprogramming is executed in a certain reprogramming loop

- It is necessary to execute additional programming processing during the course of the chip program/program-verify procedure. However, once 128-byte-unit programming is finished, additional programming should not be carried out on the same address area. When executing reprogramming, an erase must be executed first. Note that normal operation of reads, etc., is not guaranteed if additional programming is performed on addresses for which a program/program-verify operation has finished.

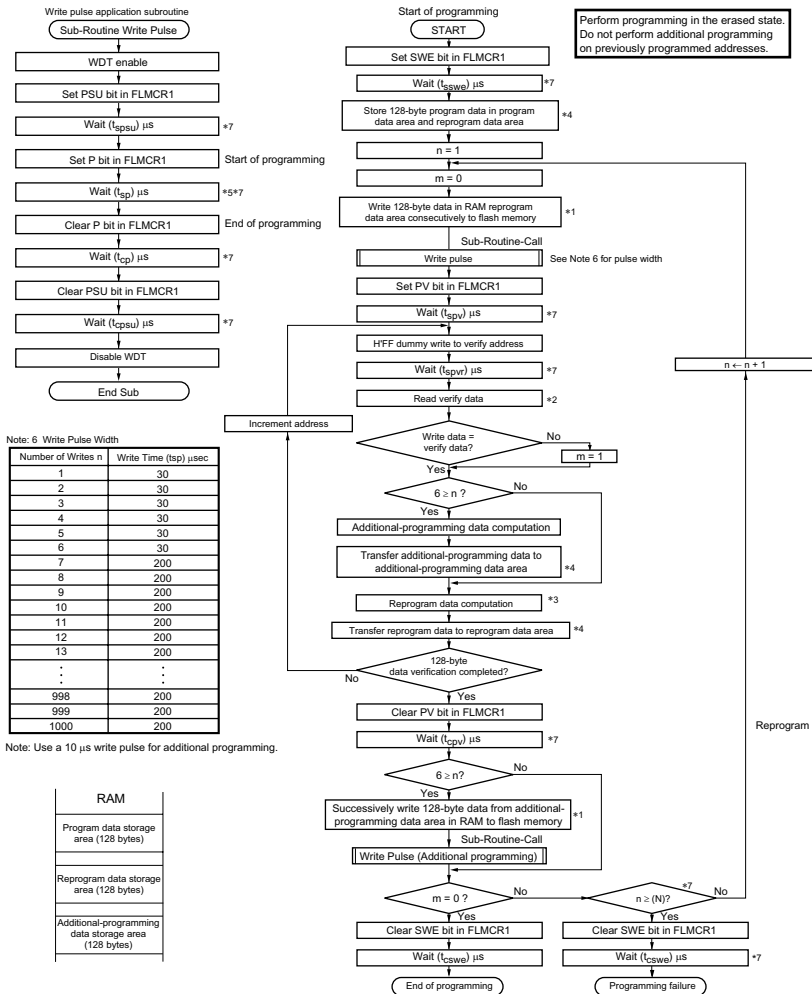

Note: 6 Write Pulse Width

Number of Writes n	Write Time (tsp) μsec
1	30
2	30
3	30
4	30
5	30
6	30
7	200
8	200
9	200
10	200
11	200
12	200
13	200
...	...
998	200
999	200
1000	200

Note: Use a 10 μs write pulse for additional programming.

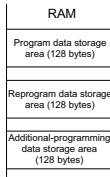

- Notes:
- Data transfer is performed by byte transfer. The lower 8 bits of the first address written to must be H00 or H80. A 128-byte data transfer must be performed even if writing fewer than 128 bytes; in this case, HFF data must be written to the extra addresses.
 - Verify data is read in 16-bit (word) units.
 - Reprogram data is determined by the operation shown in the table below (comparison between the data stored in the program data area and the verify data). Bits for which the reprogram data is 0 are programmed in the next reprogramming loop. Therefore, even bits for which programming has been completed will be subjected to programming once again if the result of the subsequent verify operation is NG.
 - A 128-byte area for storing program data, a 128-byte area for storing reprogram data, and a 128-byte area for storing additional data and the verify data). Bits for which the reprogram data area and additional data area are modified as programming proceeds.
 - A write pulse of 30 μs or 200 μs is applied according to the progress of the programming operation. See Note 6 for details of the pulse widths. When writing of additional-programming data is executed, a 10 μs write pulse should be applied. Reprogram data 'X' means reprogram data when the write pulse is applied.
 - The wait times and value of N are shown in section 24.2.7, 24.3.7, and 24.4.7, Flash Memory Characteristics.

Reprogram Data Computation Table				Additional-Programming Data Computation Table			
Original Data (D)	Verify Data (V)	Reprogram Data (X)	Comments	Reprogram Data (X)	Verify Data (V)	Additional-Programming Data (Y)	Comments
0	0	1	Programming completed	0	0	0	Additional programming to be executed
0	1	0	Programming incomplete; reprogram	0	1	1	Additional programming not to be executed
1	0	1		1	0	1	Additional programming not to be executed
1	1	1	Still in erased state; no action	1	1	1	Additional programming not to be executed

Figure 21B-12 Program/Program-Verify Flowchart



21B.9.3 Erase Mode

When erasing flash memory, the single-block erase flowchart shown in figure 21B-13 should be followed.

The wait times after bits are set or cleared in the flash memory control register 1 (FLMCR1) and the maximum number of erase operations (N) are shown in table 24-10 in section 24.2.7 and 24.3.7, Flash Memory Characteristics.

To erase flash memory contents, make a 1-bit setting for the flash memory area to be erased in erase block register 1 and 2 (EBR1, EBR2) at least (t_{sswe}) μ s after setting the SWE bit to 1 in FLMCR1. Next, the watchdog timer (WDT) is set to prevent overerasing due to program runaway, etc. Set a value greater than (t_{se}) ms + (t_{sesu} + t_{ce} + t_{cesu}) μ s as the WDT overflow period. Preparation for entering erase mode (erase setup) is performed next by setting the ESU bit in FLMCR1. The operating mode is then switched to erase mode by setting the E bit in FLMCR1 after the elapse of at least (t_{sesu}) μ s. The time during which the E bit is set is the flash memory erase time. Ensure that the erase time does not exceed (t_{se}) ms.

Note: With flash memory erasing, preprogramming (setting all memory data in the memory to be erased to all 0) is not necessary before starting the erase procedure.

21B.9.4 Erase-Verify Mode

In erase-verify mode, data is read after memory has been erased to check whether it has been correctly erased.

After the elapse of the fixed erase time, clear the E bit in FLMCR1, then wait for at least (t_{ce}) μ s before clearing the ESU bit to exit erase mode. After exiting erase mode, the watchdog timer setting is also cleared. The operating mode is then switched to erase-verify mode by setting the EV bit in FLMCR1. Before reading in erase-verify mode, a dummy write of HFF data should be made to the addresses to be read. The dummy write should be executed after the elapse of (t_{sev}) μ s or more. When the flash memory is read in this state (verify data is read in 16-bit units), the data at the latched address is read. Wait at least (t_{sevr}) μ s after the dummy write before performing this read operation. If the read data has been erased (all 1), a dummy write is performed to the next address, and erase-verify is performed. If the read data is unerased, set erase mode again, and repeat the erase/erase-verify sequence as before. The maximum number of repetitions of the erase/erase-verify sequence is indicated by the maximum erase count (N). When verification is completed, exit erase-verify mode, and wait for at least (t_{cev}) μ s. If erasure has been completed on all the erase blocks, clear the SWE bit in FLMCR1, and leave a wait time of at least (t_{cswe}) μ s.

If erasing multiple blocks, set a single bit in EBR1/EBR2 for the next block to be erased, and repeat the erase/erase-verify sequence as before.

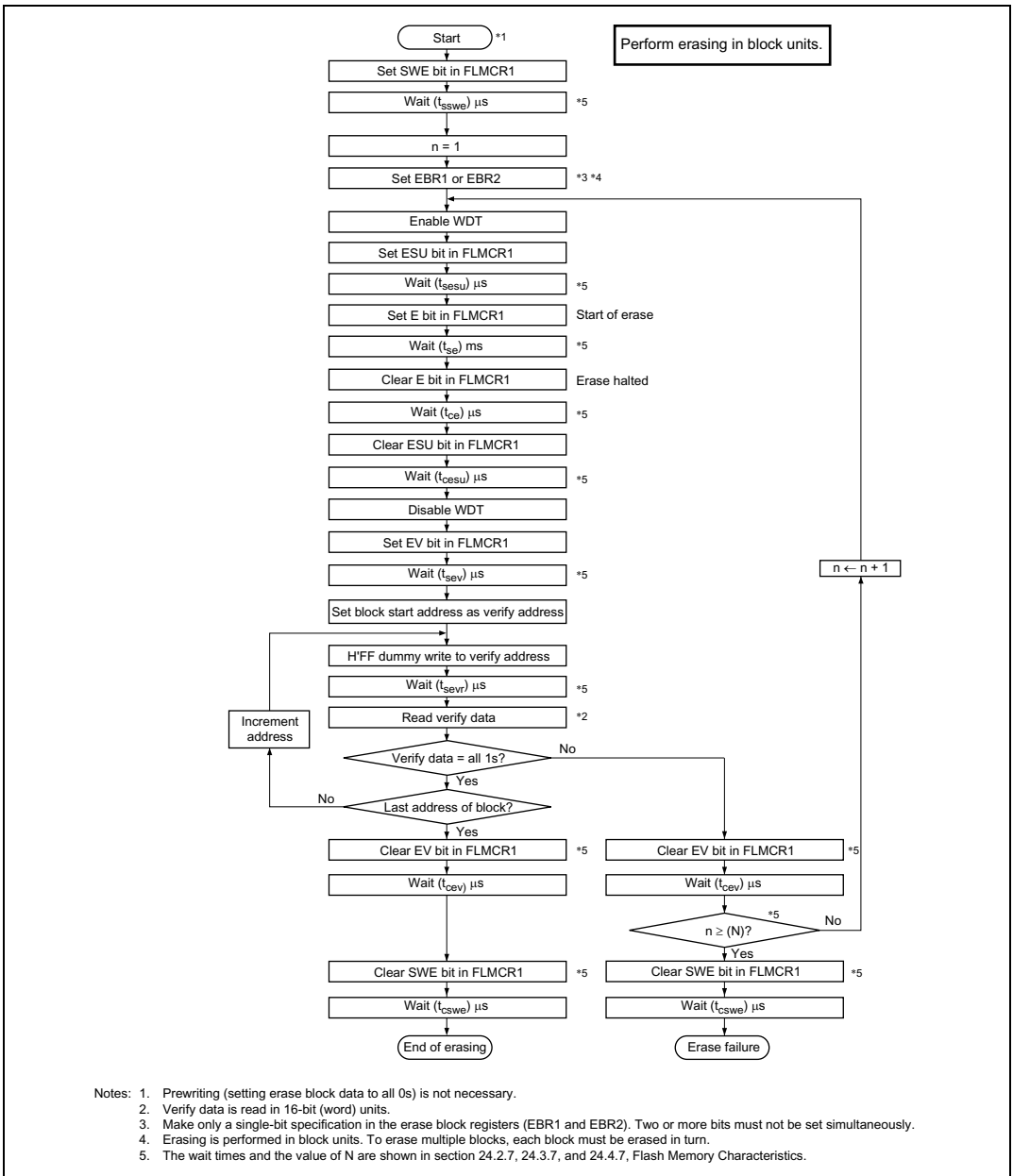

Figure 21B-13 Erase/Eraser-Verify Flowchart

21B.10 Protection

There are three kinds of flash memory program/erase protection: hardware protection, software protection, and error protection.

21B.10.1 Hardware Protection

Hardware protection refers to a state in which programming/erasing of flash memory is forcibly disabled or aborted. Hardware protection is reset by settings in flash memory control register 1 (FLMCR1), flash memory control register 2 (FLMCR2), erase block register 1 (EBR1), and erase block register 2 (EBR2). The FLMCR1, FLMCR2, EBR1, and EBR2 settings are retained in the error-protected state (See table 21B-11).

Table 21B-11 Hardware Protection

Item	Description	Functions	
		Program	Erase
FWE pin protection	<ul style="list-style-type: none"> When a low level is input to the FWE pin, FLMCR1, FLMCR2, (except bit FLER) EBR1, and EBR2 are initialized, and the program/erase-protected state is entered. 	Yes	Yes
Reset/standby protection	<ul style="list-style-type: none"> In a reset (including a WDT reset) and in standby mode, FLMCR1, FLMCR2, EBR1, and EBR2 are initialized, and the program/erase-protected state is entered. In a reset via the $\overline{\text{RES}}$ pin, the reset state is not entered unless the $\overline{\text{RES}}$ pin is held low until oscillation stabilizes after powering on. In the case of a reset during operation, hold the $\overline{\text{RES}}$ pin low for the $\overline{\text{RES}}$ pulse width specified in the AC Characteristics section. 	Yes	Yes

21B.10.2 Software Protection

Software protection can be implemented by setting the SWE bit in FLMCR1, erase block register 1 (EBR1), erase block register 2 (EBR2), and the RAMS bit in the RAM emulation register (RAMER). When software protection is in effect, setting the P or E bit in flash memory control register 1 (FLMCR1), does not cause a transition to program mode or erase mode (See table 21B-12).

Table 21B-12 Software Protection

Item	Description	Functions	
		Program	Erase
SWE bit protection	<ul style="list-style-type: none"> Setting bit SWE in FLMCR1 to 0 will place area on-chip flash memory in the program/erase-protected state (Execute the program in the on-chip RAM, external memory). 	Yes	Yes
Block specification protection	<ul style="list-style-type: none"> Erase protection can be set for individual blocks by settings in erase block register 1 (EBR1) and erase block register 2 (EBR2). Setting EBR1 and EBR2 to H'00 places all blocks in the erase-protected state. 	—	Yes
Emulation protection	<ul style="list-style-type: none"> Setting the RAMS bit to 1 in the RAM emulation register (RAMER) places all blocks in the program/erase-protected state. 	Yes	Yes

21B.10.3 Error Protection

In error protection, an error is detected when chip runaway occurs during flash memory programming/erasing, or operation is not performed in accordance with the program/erase algorithm, and the program/erase operation is aborted. Aborting the program/erase operation prevents damage to the flash memory due to overprogramming or overerasing.

If the chip malfunctions during flash memory programming/erasing, the FLER bit is set to 1 in FLMCR2 and the error protection state is entered. The FLMCR1, FLMCR2, EBR1, and EBR2 settings are retained, but program mode or erase mode is aborted at the point at which the error occurred. Program mode or erase mode cannot be re-entered by re-setting the P or E bit. However, PV and EV bit setting is enabled, and a transition can be made to verify mode.

FLER bit setting conditions are as follows:

1. When the flash memory of the relevant address area is read during programming/erasing (including vector read and instruction fetch)
2. Immediately after exception handling (excluding a reset) during programming/erasing
3. When a SLEEP instruction (including software standby) is executed during programming/erasing
4. When the CPU releases the bus to the DTC

Error protection is released only by a reset and in hardware standby mode.

Figure 21B-14 shows the flash memory state transition diagram.

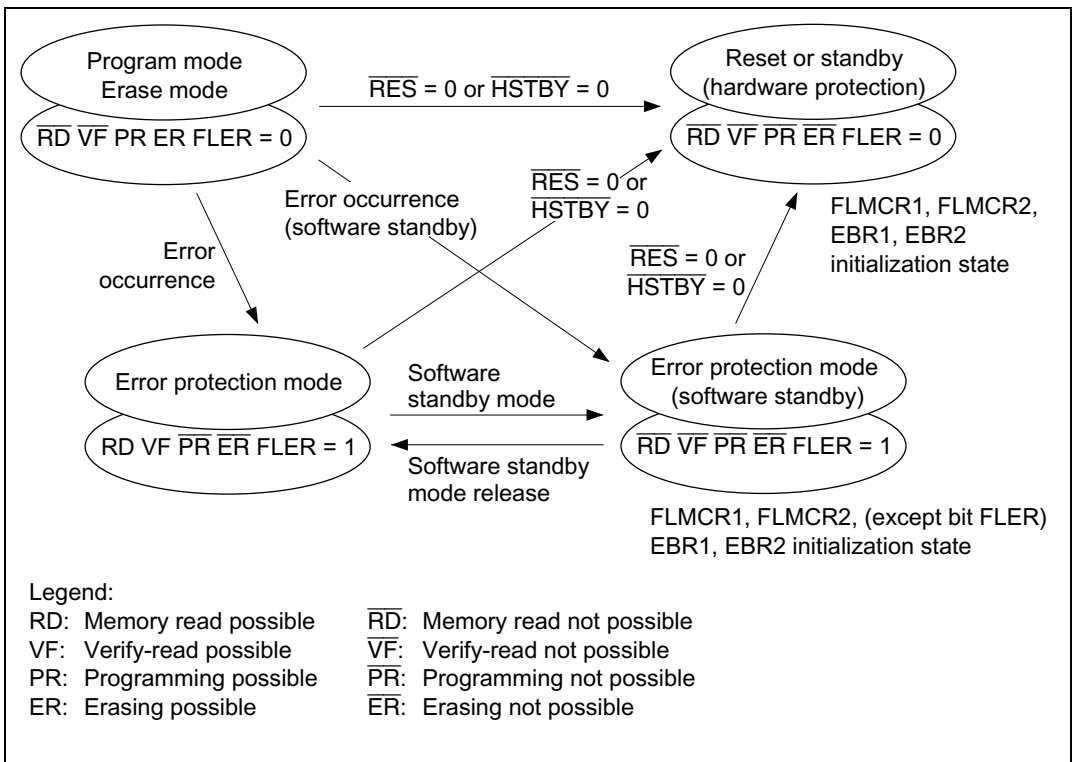

Figure 21B-14 Flash Memory State Transitions

21B.11 Flash Memory Emulation in RAM

Making a setting in the RAM emulation register (RAMER) enables part of RAM to be overlapped onto the flash memory area so that data to be written to flash memory can be emulated in RAM in real time. After the RAMER setting has been made, accesses cannot be made from the flash memory area or the RAM area overlapping flash memory. Emulation can be performed in user mode and user program mode. Figure 21B-15 shows an example of emulation of real-time flash memory programming.

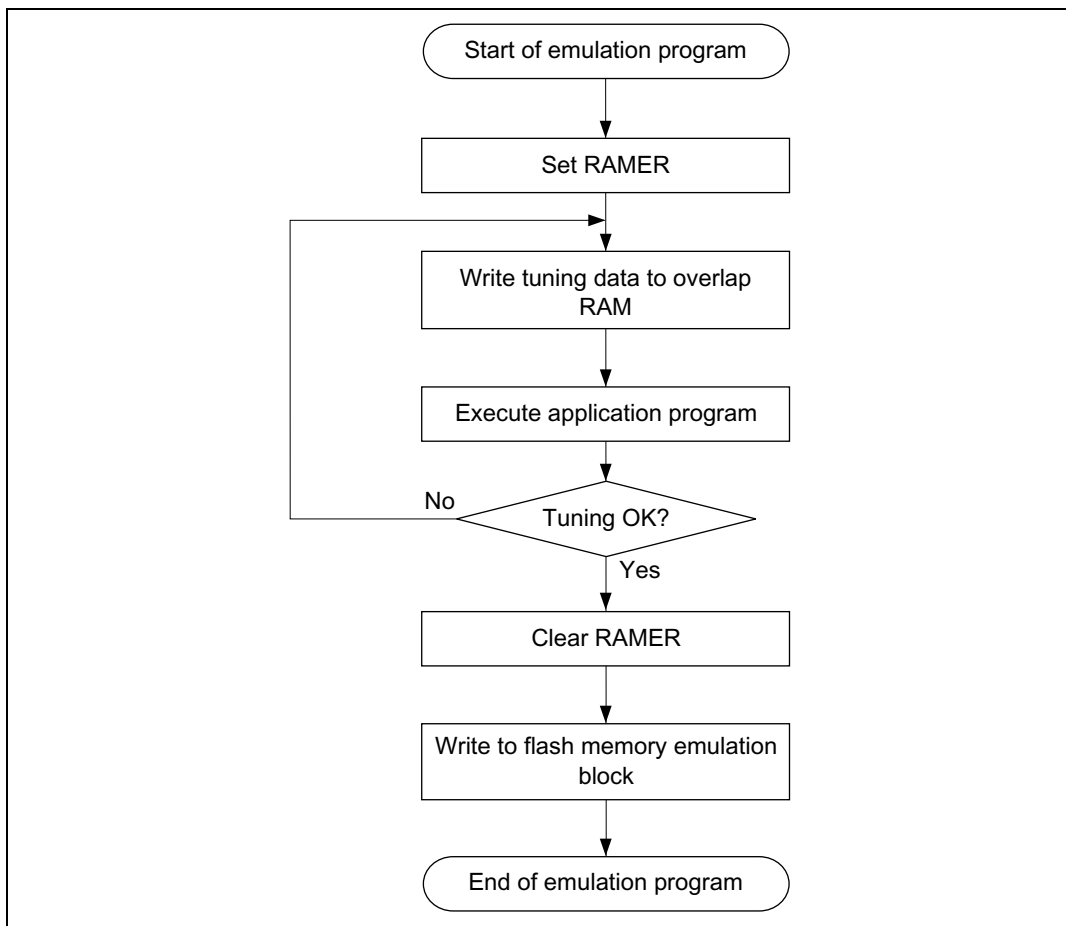

Figure 21B-15 Flowchart for Flash Memory Emulation in RAM

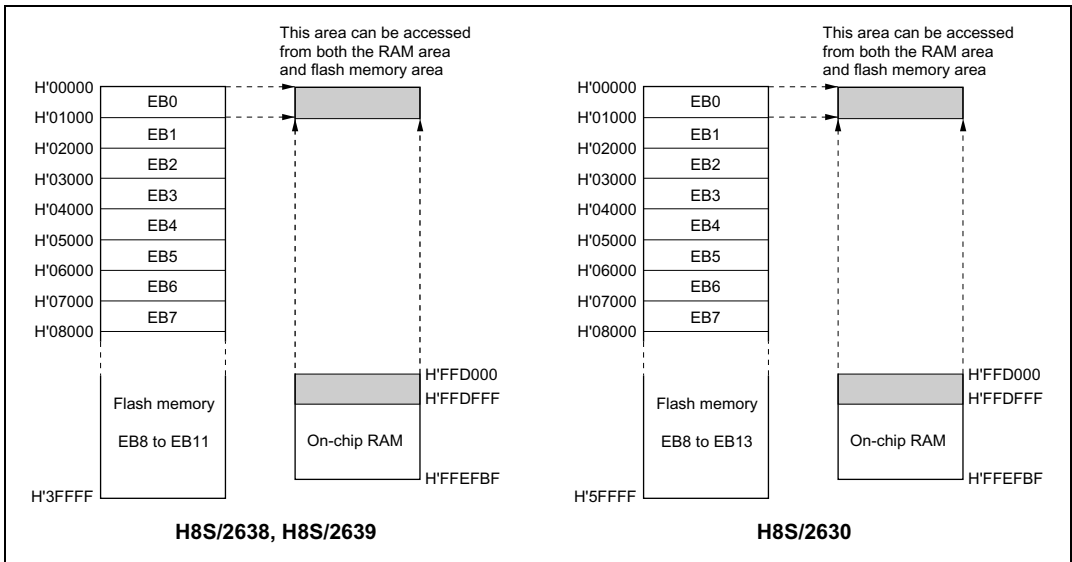

Figure 21B-16 Example of RAM Overlap Operation

Example in which Flash Memory Block Area EB0 is Overlapped

1. Set bits RAMS, RAM2 to RAM0 in RAMER to 1, 0, 0, 0, to overlap part of RAM onto the area (EB0) for which real-time programming is required.
2. Real-time programming is performed using the overlapping RAM.
3. After the program data has been confirmed, the RAMS bit is cleared, releasing RAM overlap.
4. The data written in the overlapping RAM is written into the flash memory space (EB0).

- Notes:
1. When the RAMS bit is set to 1, program/erase protection is enabled for all blocks regardless of the value of RAM2 to RAM0 (emulation protection). In this state, setting the P or E bit in flash memory control register 1 (FLMCR1), will not cause a transition to program mode or erase mode. When actually programming or erasing a flash memory area, the RAMS bit should be cleared to 0.
 2. A RAM area cannot be erased by execution of software in accordance with the erase algorithm while flash memory emulation in RAM is being used.
 3. Block area EB0 contains the vector table. When performing RAM emulation, the vector table is needed in the overlap RAM.

21B.12 Interrupt Handling when Programming/Erasing Flash Memory

All interrupts, including NMI interrupt is disabled when flash memory is being programmed or erased (when the P or E bit is set in FLMCR1), and while the boot program is executing in boot mode*¹, to give priority to the program or erase operation. There are three reasons for this:

1. Interrupt during programming or erasing might cause a violation of the programming or erasing algorithm, with the result that normal operation could not be assured.
2. In the interrupt exception handling sequence during programming or erasing, the vector would not be read correctly*², possibly resulting in MCU runaway.
3. If interrupt occurred during boot program execution, it would not be possible to execute the normal boot mode sequence.

For these reasons, in on-board programming mode alone there are conditions for disabling interrupt, as an exception to the general rule. However, this provision does not guarantee normal erasing and programming or MCU operation. All requests, including NMI interrupt, must therefore be restricted inside and outside the MCU when programming or erasing flash memory. NMI interrupt is also disabled in the error-protection state while the P or E bit remains set in FLMCR1.

- Notes:
1. Interrupt requests must be disabled inside and outside the MCU until the programming control program has completed programming.
 2. The vector may not be read correctly in this case for the following two reasons:
 - If flash memory is read while being programmed or erased (while the P or E bit is set in FLMCR1), correct read data will not be obtained (undetermined values will be returned).
 - If the interrupt entry in the vector table has not been programmed yet, interrupt exception handling will not be executed correctly.

21B.13 Flash Memory Programmer Mode

Programs and data can be written and erased in programmer mode as well as in the on-board programming modes. In programmer mode, flash memory read mode, auto-program mode, auto-erase mode, and status read mode are supported. In auto-program mode, auto-erase mode, and status read mode, a status polling procedure is used, and in status read mode, detailed internal signals are output after execution of an auto-program or auto-erase operation.

In programmer mode, set the mode pins to programmer mode (see table 21B-13) and input a 12 MHz input clock.

Table 21B-13 shows the pin settings for programmer mode.

Table 21B-13 Programmer Mode Pin Settings

Pin Names	Settings
Mode pins: MD2, MD1, MD0	Low level input to MD2, MD1, and MD0.
Mode setting pins: PF0, P16, P14	High level input to PF0, low level input to P16 and P14
FWE pin	High level input (in auto-program and auto-erase modes)
$\overline{\text{RES}}$ pin	Reset circuit
XTAL, EXTAL, PLLCAP, PLLVSS pins	Oscillator circuit
VCL	Internal voltage step-down circuit

21B.13.1 Socket Adapter and Memory Map

In programmer mode in which the PROM writer is used, reading from memory (verification), writing, and initializing the flash memory (erasing all of its contents) are enabled. At this time, a dedicated conversion socket adapter must be attached to a general-purpose PROM writer. Table 21B-14 shows the types of the socket adapters. For programmer mode on this LSI, one of the socket adapters listed in table 21B-14 should be used.

Table 21B-14 Type of Socket Adapter

Product Name	Package Type	Socket Adapter Type	Manufacturer
HD64F2638F	128 pin QFP (FP-128B)	ME2636ESHF1H	Minato Electronics Inc.
HD64F2638UF		HF2636Q128D4001	Data I/O Japan Corporation
HD64F2638WF			
HD64F2639UF			
HD64F2639WF			
HD64F2630F*			
HD64F2630UF*			
HD64F2630WF*			

Note: * Under development

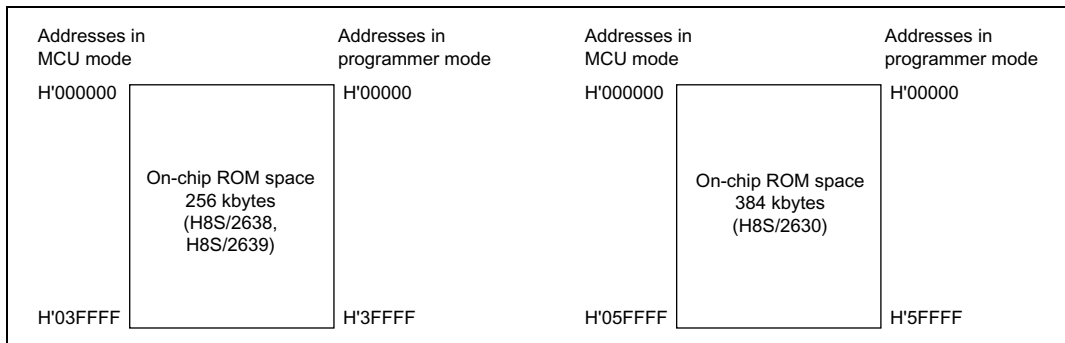

Figure 21B-17 On-Chip ROM Memory Map

21B.13.2 Programmer Mode Operation

Table 21B-15 shows how the different operating modes are set when using programmer mode, and table 21B-16 lists the commands used in programmer mode. Details of each mode are given below.

- **Memory Read Mode**
Memory read mode supports byte reads.
- **Auto-Program Mode**
Auto-program mode supports programming of 128 bytes at a time. Status polling is used to confirm the end of auto-programming.
- **Auto-Erase Mode**
Auto-erase mode supports automatic erasing of the entire flash memory. Status polling is used to confirm the end of auto-programming.
- **Status Read Mode**
Status polling is used for auto-programming and auto-erasing, and normal termination can be confirmed by reading the I/O6 signal. In status read mode, error information is output if an error occurs.

Table 21B-15 Settings for Various Operating Modes in Programmer Mode

Mode	Pin Names				I/O7 to I/O0	A18 to A0
	FWE	\overline{CE}	\overline{OE}	\overline{WE}		
Read	H or L	L	L	H	Data output	Ain ^{*2}
Output disable	H or L	L	H	H	Hi-Z	X
Command write	H or L ^{*3}	L	H	L	Data input	Ain ^{*2}
Chip disable ^{*1}	H or L	H	X	X	Hi-Z	X

Notes: 1. Chip disable is not a standby state; internally, it is an operation state.

2. Ain indicates that there is also address input in auto-program mode.

3. For command writes in auto-program and auto-erase modes, input a high level to the FWE pin.

Table 21B-16 Programmer Mode Commands

Command Name	Number of Cycles	1st Cycle			2nd Cycle		
		Mode	Address	Data	Mode	Address	Data
Memory read mode	1 + n	Write	X	H'00	Read	RA	Dout
Auto-program mode	129	Write	X	H'40	Write	WA	Din
Auto-erase mode	2	Write	X	H'20	Write	X	H'20
Status read mode	2	Write	X	H'71	Write	X	H'71

Notes: 1. In auto-program mode, 129 cycles are required for command writing by a simultaneous 128-byte write.

2. In memory read mode, the number of cycles depends on the number of address write cycles (n).

21B.13.3 Memory Read Mode

1. After completion of auto-program/auto-erase/status read operations, a transition is made to the command wait state. When reading memory contents, a transition to memory read mode must first be made with a command write, after which the memory contents are read.
2. In memory read mode, command writes can be performed in the same way as in the command wait state.
3. Once memory read mode has been entered, consecutive reads can be performed.
4. After powering on, memory read mode is entered.

Table 21B-17 AC Characteristics in Transition to Memory Read ModeConditions: $V_{CC} = 5.0 \text{ V} \pm 0.5 \text{ V}$, $V_{SS} = 0 \text{ V}$, $T_a = 25^\circ\text{C} \pm 5^\circ\text{C}$

Item	Symbol	Min.	Max.	Unit
Command write cycle	t_{nxtc}	20	—	μs
$\overline{\text{CE}}$ hold time	t_{ceh}	0	—	ns
$\overline{\text{CE}}$ setup time	t_{ces}	0	—	ns
Data hold time	t_{dh}	50	—	ns
Data setup time	t_{ds}	50	—	ns
Write pulse width	t_{wep}	70	—	ns
$\overline{\text{WE}}$ rise time	t_r	—	30	ns
$\overline{\text{WE}}$ fall time	t_f	—	30	ns

**Figure 21B-18 Timing Waveforms for Memory Read after Memory Write**

Table 21B-18 AC Characteristics in Transition from Memory Read Mode to Another ModeConditions: $V_{CC} = 5.0\text{ V} \pm 0.5\text{ V}$, $V_{SS} = 0\text{ V}$, $T_a = 25^\circ\text{C} \pm 5^\circ\text{C}$

Item	Symbol	Min.	Max.	Unit
Command write cycle	t_{nxtc}	20	—	μs
$\overline{\text{CE}}$ hold time	t_{ceh}	0	—	ns
$\overline{\text{CE}}$ setup time	t_{ces}	0	—	ns
Data hold time	t_{dh}	50	—	ns
Data setup time	t_{ds}	50	—	ns
Write pulse width	t_{wep}	70	—	ns
$\overline{\text{WE}}$ rise time	t_r	—	30	ns
$\overline{\text{WE}}$ fall time	t_f	—	30	ns

**Figure 21B-19 Timing Waveforms in Transition from Memory Read Mode to Another Mode**

Table 21B-19 AC Characteristics in Memory Read ModeConditions: $V_{CC} = 5.0 \text{ V} \pm 0.5 \text{ V}$, $V_{SS} = 0 \text{ V}$, $T_a = 25^\circ\text{C} \pm 5^\circ\text{C}$

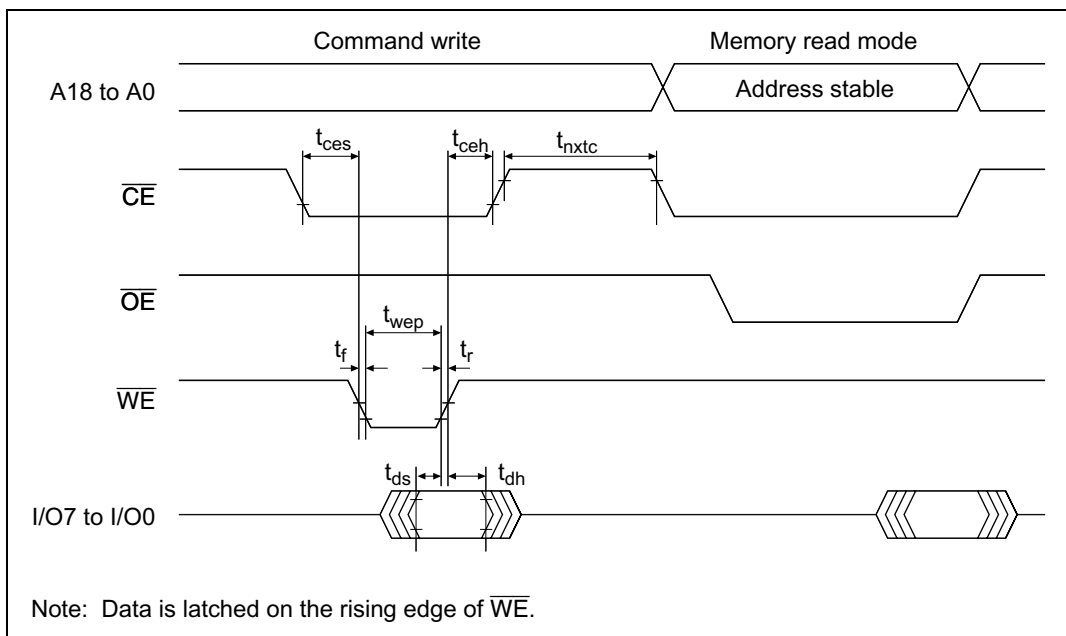
Item	Symbol	Min.	Max.	Unit
Access time	t_{acc}	—	20	μs
$\overline{\text{CE}}$ output delay time	t_{ce}	—	150	ns
$\overline{\text{OE}}$ output delay time	t_{oe}	—	150	ns
Output disable delay time	t_{df}	—	100	ns
Data output hold time	t_{oh}	5	—	ns

**Figure 21B-20 $\overline{\text{CE}}$ and $\overline{\text{OE}}$ Enable State Read Timing Waveforms****Figure 21B-21 $\overline{\text{CE}}$ and $\overline{\text{OE}}$ Clock System Read Timing Waveforms**

21B.13.4 Auto-Program Mode

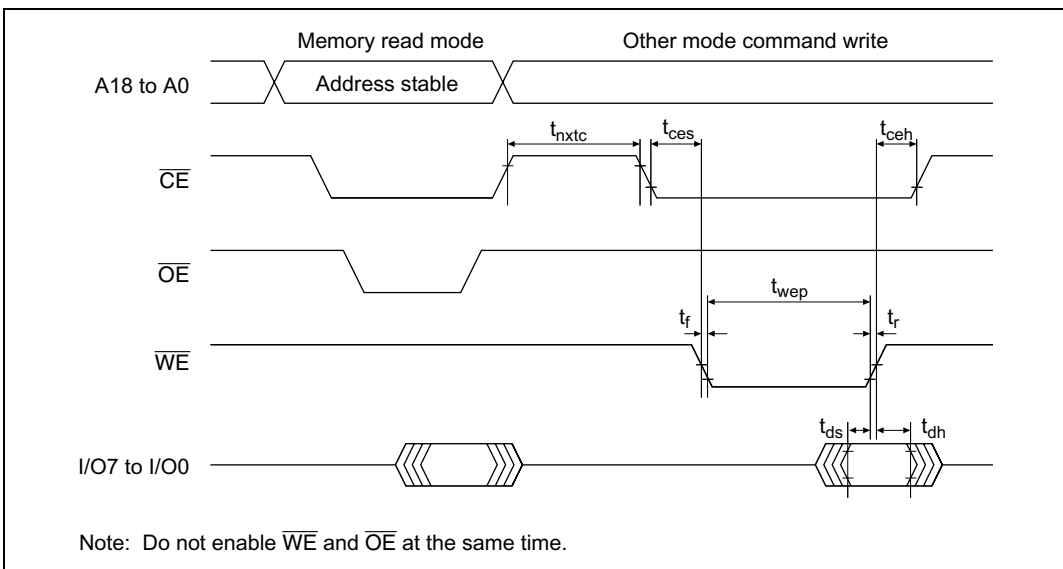
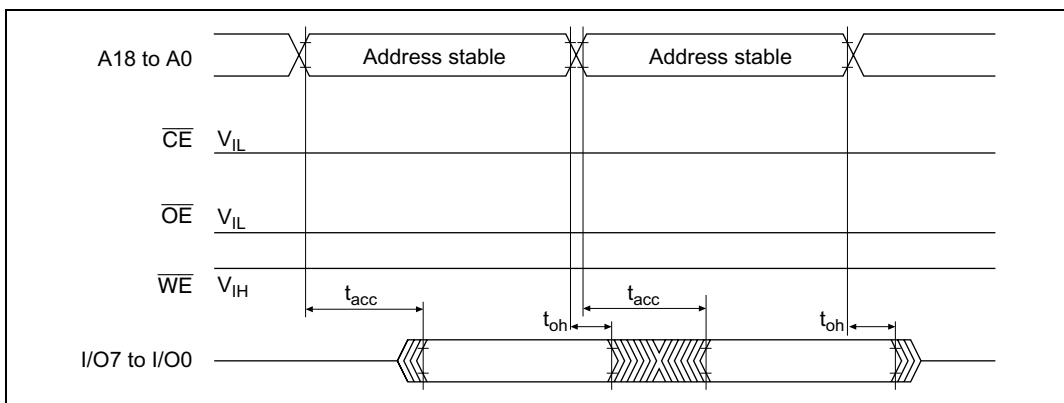
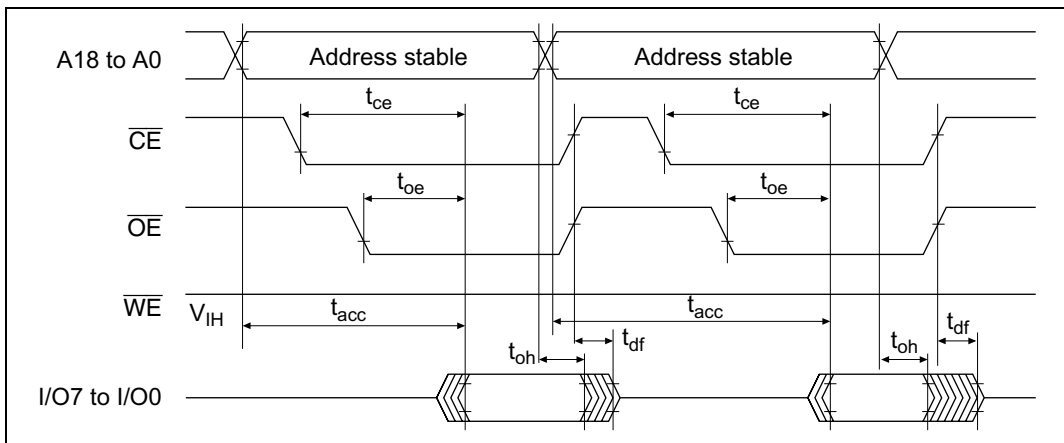
1. In auto-program mode, 128 bytes are programmed simultaneously. This should be carried out by executing 128 consecutive byte transfers.
2. A 128-byte data transfer is necessary even when programming fewer than 128 bytes. In this case, H'FF data must be written to the extra addresses.
3. The lower 7 bits of the transfer address must be low. If a value other than an effective address is input, processing will switch to a memory write operation but a write error will be flagged.
4. Memory address transfer is performed in the second cycle (figure 21B-22). Do not perform transfer after the third cycle.
5. Do not perform a command write during a programming operation.
6. Perform one auto-program operation for a 128-byte block for each address. Two or more additional programming operations cannot be performed on a previously programmed address block.
7. Confirm normal end of auto-programming by checking I/O6. Alternatively, status read mode can also be used for this purpose (I/O7 status polling uses the auto-program operation end decision pin).
8. Status polling I/O6 and I/O7 pin information is retained until the next command write. As long as the next command write has not been performed, reading is possible by enabling \overline{CE} and \overline{OE} .

Table 21B-20 AC Characteristics in Auto-Program ModeConditions: $V_{CC} = 5.0\text{ V} \pm 0.5\text{ V}$, $V_{SS} = 0\text{ V}$, $T_a = 25^\circ\text{C} \pm 5^\circ\text{C}$

Item	Symbol	Min.	Max.	Unit
Command write cycle	t_{nxtc}	20	—	μs
$\overline{\text{CE}}$ hold time	t_{ceh}	0	—	ns
$\overline{\text{CE}}$ setup time	t_{ces}	0	—	ns
Data hold time	t_{dh}	50	—	ns
Data setup time	t_{ds}	50	—	ns
Write pulse width	t_{wep}	70	—	ns
Status polling start time	t_{wsts}	1	—	ms
Status polling access time	t_{spa}	—	150	ns
Address setup time	t_{as}	0	—	ns
Address hold time	t_{ah}	60	—	ns
Memory write time	t_{write}	1	3000	ms
Write setup time	t_{pns}	100	—	ns
Write end setup time	t_{pnh}	100	—	ns
$\overline{\text{WE}}$ rise time	t_r	—	30	ns
$\overline{\text{WE}}$ fall time	t_f	—	30	ns

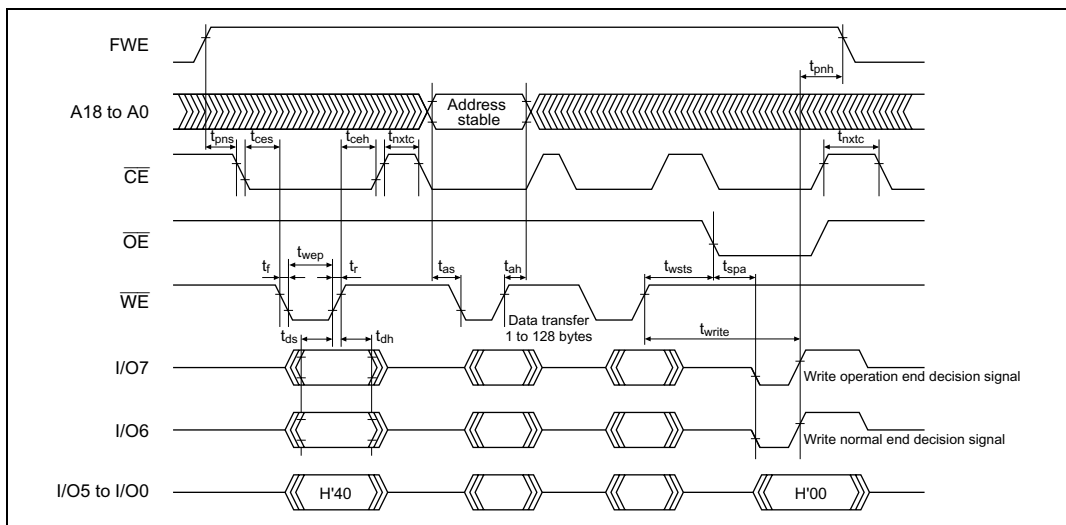
**Figure 21B-22 Auto-Program Mode Timing Waveforms**

21B.13.5 Auto-Erase Mode

1. Auto-erase mode supports only entire memory erasing.
2. Do not perform a command write during auto-erasing.
3. Confirm normal end of auto-erasing by checking I/O6. Alternatively, status read mode can also be used for this purpose (I/O7 status polling uses the auto-erase operation end decision pin).
4. Status polling I/O6 and I/O7 pin information is retained until the next command write. As long as the next command write has not been performed, reading is possible by enabling $\overline{\text{CE}}$ and $\overline{\text{OE}}$.

Table 21B-21 AC Characteristics in Auto-Erase ModeConditions: $V_{\text{CC}} = 5.0 \text{ V} \pm 0.5 \text{ V}$, $V_{\text{SS}} = 0 \text{ V}$, $T_{\text{a}} = 25^{\circ}\text{C} \pm 5^{\circ}\text{C}$

Item	Symbol	Min.	Max.	Unit
Command write cycle	t_{nxtc}	20	—	μs
$\overline{\text{CE}}$ hold time	t_{ceh}	0	—	ns
$\overline{\text{CE}}$ setup time	t_{ces}	0	—	ns
Data hold time	t_{dh}	50	—	ns
Data setup time	t_{ds}	50	—	ns
Write pulse width	t_{wep}	70	—	ns
Status polling start time	t_{ests}	1	—	ms
Status polling access time	$t_{\text{s pa}}$	—	150	ns
Memory erase time	t_{erase}	100	40000	ms
Erase setup time	t_{ens}	100	—	ns
Erase end setup time	t_{enh}	100	—	ns
$\overline{\text{WE}}$ rise time	t_{r}	—	30	ns
$\overline{\text{WE}}$ fall time	t_{f}	—	30	ns

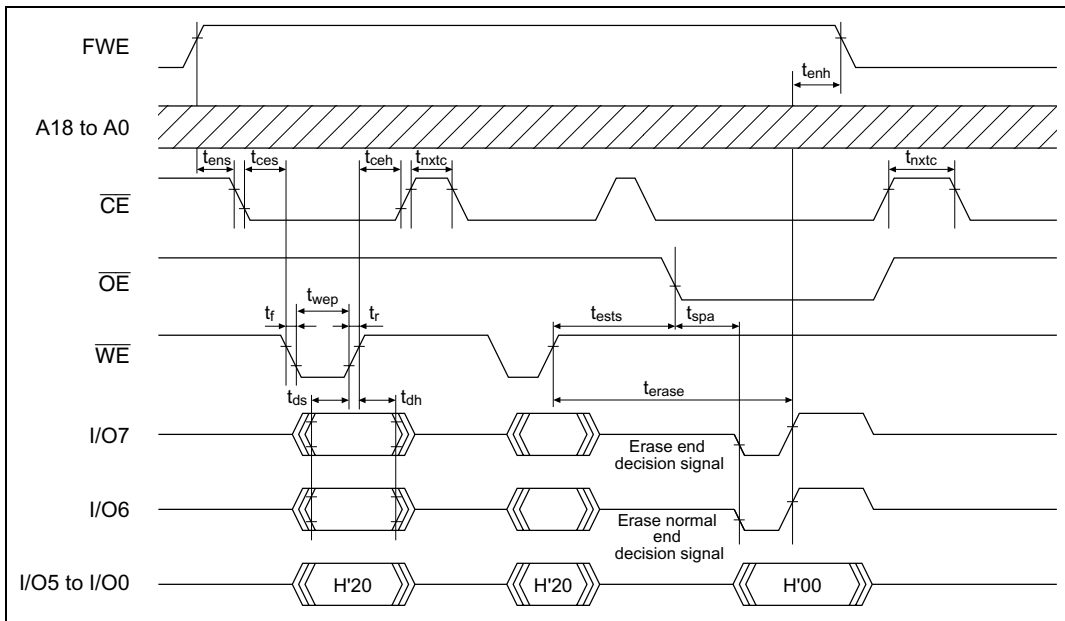

Figure 21B-23 Auto-Erase Mode Timing Waveforms

21B.13.6 Status Read Mode

1. Status read mode is provided to identify the kind of abnormal end. Use this mode when an abnormal end occurs in auto-program mode or auto-erase mode.
2. The return code is retained until a command write other than a status read mode command write is executed.

Table 21B-22 AC Characteristics in Status Read Mode

Conditions: $V_{CC} = 5.0\text{ V} \pm 0.5\text{ V}$, $V_{SS} = 0\text{ V}$, $T_a = 25^\circ\text{C} \pm 5^\circ\text{C}$

Item	Symbol	Min.	Max.	Unit
Read time after command write	t_{nxtc}	20	—	μs
$\overline{\text{CE}}$ hold time	t_{ceh}	0	—	ns
$\overline{\text{CE}}$ setup time	t_{ces}	0	—	ns
Data hold time	t_{dh}	50	—	ns
Data setup time	t_{ds}	50	—	ns
Write pulse width	t_{wep}	70	—	ns
$\overline{\text{OE}}$ output delay time	t_{oe}	—	150	ns
Disable delay time	t_{df}	—	100	ns
$\overline{\text{CE}}$ output delay time	t_{ce}	—	150	ns
$\overline{\text{WE}}$ rise time	t_r	—	30	ns
$\overline{\text{WE}}$ fall time	t_f	—	30	ns

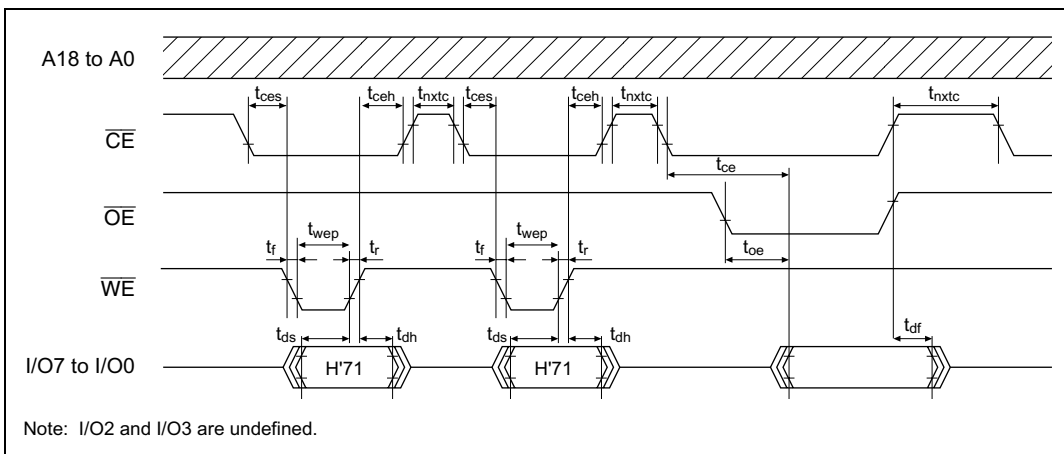

Figure 21B-24 Status Read Mode Timing Waveforms

Table 21B-23 Status Read Mode Return Commands

Pin Name	I/O7	I/O6	I/O5	I/O4	I/O3	I/O2	I/O1	I/O0
Attribute	Normal end decision	Command error	Programming error	Erase error	—	—	Programming or erase count exceeded	Effective address error
Initial value	0	0	0	0	0	0	0	0
Indications	Normal end: 0 Abnormal end: 1	Command error: 1 Otherwise: 0	Programming error: 1 Otherwise: 0	Erasing error: 1 Otherwise: 0	—	—	Count exceeded: 1 Otherwise: 0	Effective address error: 1 Otherwise: 0

Note: I/O2 and I/O3 are undefined.

21B.13.7 Status Polling

1. The I/O7 status polling flag indicates the operating status in auto-program/auto-erase mode.
2. The I/O6 status polling flag indicates a normal or abnormal end in auto-program/auto-erase mode.

Table 21B-24 Status Polling Output Truth Table

Pin Name	During Internal Operation	Abnormal End	—	Normal End
I/O7	0	1	0	1
I/O6	0	0	1	1
I/O0 to I/O5	0	0	0	0

21B.13.8 Programmer Mode Transition Time

Commands cannot be accepted during the oscillation stabilization period or the programmer mode setup period. After the programmer mode setup time, a transition is made to memory read mode.

Table 21B-25 Stipulated Transition Times to Command Wait State

Item	Symbol	Min.	Max.	Unit
Standby release (oscillation stabilization time)	t_{osc1}	30	—	ms
Programmer mode setup time	t_{bmV}	10	—	ms
V_{CC} hold time	t_{dwn}	0	—	ms

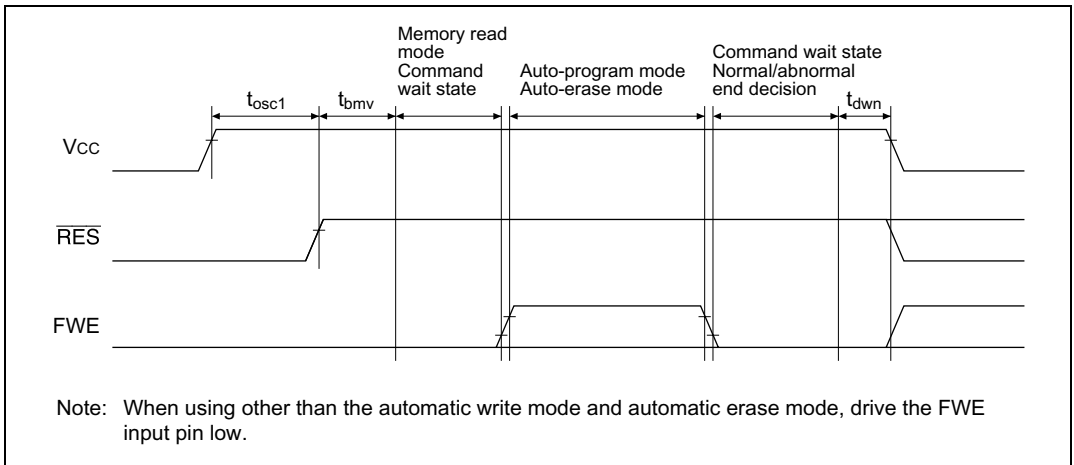

Figure 21B-25 Oscillation Stabilization Time, Boot Program Transfer Time, and Power-Down Sequence

21B.13.9 Notes on Memory Programming

1. When programming addresses which have previously been programmed, carry out auto-erasing before auto-programming.
2. When performing programming using programmer mode on a chip that has been programmed/erased in an on-board programming mode, auto-erasing is recommended before carrying out auto-programming.

- Notes:
1. The flash memory is initially in the erased state when the device is shipped by Renesas Technology. For other chips for which the erasure history is unknown, it is recommended that auto-erasing be executed to check and supplement the initialization (erase) level.
 2. Auto-programming should be performed once only on the same address block. Additional programming cannot be performed on previously programmed address blocks.

21B.14 Flash Memory and Power-Down States

In addition to its normal operating state, the flash memory has power-down states in which power consumption is reduced by halting part or all of the internal power supply circuitry.

There are three flash memory operating states:

- (1) Normal operating mode: The flash memory can be read and written to.
- (2) Power-down mode: Part of the power supply circuitry is halted, and the flash memory can be read when the LSI is operating on the subclock.
- (3) Standby mode: All flash memory circuits are halted, and the flash memory cannot be read or written to.

States (2) and (3) are flash memory power-down states. Table 21B-26 shows the correspondence between the operating states of the LSI and the flash memory.

Table 21B-26 Flash Memory Operating States

LSI Operating State	Flash Memory Operating State
High-speed mode	Normal mode (read/write)
Medium-speed mode	
Sleep mode	
Subactive mode*	When PDWND = 0: Power-down mode (read-only)
Subsleep mode*	When PDWND = 1: Normal mode (read-only)
Watch mode*	Standby mode
Software standby mode	
Hardware standby mode	

Note: * Subclock functions (subactive mode, subsleep mode, and watch mode) are not available in versions other than the U-mask and W-mask versions.

21B.14.1 Notes on Power-Down States

1. When the flash memory is in a power-down state, part or all of the internal power supply circuitry is halted. Therefore, a power supply circuit stabilization period must be provided when returning to normal operation. When the flash memory returns to its normal operating state from a power-down state, bits STS2 to STS0 in SBYCR must be set to provide a wait time of at least 20 μ s (power supply stabilization time), even if an oscillation stabilization period is not necessary.
2. In a power-down state, FLMCR1, FLMCR2, EBR1, EBR2, RAMER, and FLPWCR cannot be read from or written to.

21B.15 Flash Memory Programming and Erasing Precautions

Precautions concerning the use of on-board programming mode, the RAM emulation function, and programmer mode are summarized below.

Use the specified voltages and timing for programming and erasing: Applied voltages in excess of the rating can permanently damage the device. Use a PROM programmer that supports the Renesas microcomputer device type* with 256-kbyte and 512-kbyte on-chip flash memory.

Only use the specified socket adapter. Failure to observe these points may result in damage to the device.

Note: * The H8S/2638 and H8S/2639 are Renesas Technology microcomputer devices with 256 kbytes of on-chip flash memory. The H8S/2630 is a Renesas microcomputer device with 512 kbytes of on-chip flash memory (The H8S/2630 has 384 kbytes of PROM. The area from H'60000 to H'7FFFF should be programmed as H'FF).

Powering on and off (see figures 21B-26 to 21B-28): Do not apply a high level to the FWE pin until V_{CC} has stabilized. Also, drive the FWE pin low before turning off V_{CC} .

When applying or disconnecting V_{CC} power, fix the FWE pin low and place the flash memory in the hardware protection state.

The power-on and power-off timing requirements should also be satisfied in the event of a power failure and subsequent recovery.

FWE application/disconnection (see figures 21B-26 to 21B-28): FWE application should be carried out when MCU operation is in a stable condition. If MCU operation is not stable, fix the FWE pin low and set the protection state.

The following points must be observed concerning FWE application and disconnection to prevent unintentional programming or erasing of flash memory:

- Apply FWE when the V_{CC} voltage has stabilized within its rated voltage range.
Apply FWE when oscillation has stabilized (after the elapse of the oscillation stabilization time).
- In boot mode, apply and disconnect FWE during a reset.
- In user program mode, FWE can be switched between high and low level regardless of the reset state. FWE input can also be switched during execution of a program in flash memory.
- Do not apply FWE if program runaway has occurred.
- Disconnect FWE only when the SWE, ESU, PSU, EV, PV, P, and E bits in FLMCR1 are cleared.
Make sure that the SWE, ESU, PSU, EV, PV, P, and E bits are not set by mistake when applying or disconnecting FWE.

Do not apply a constant high level to the FWE pin: Apply a high level to the FWE pin only when programming or erasing flash memory. A system configuration in which a high level is constantly applied to the FWE pin should be avoided. Also, while a high level is applied to the FWE pin, the watchdog timer should be activated to prevent overprogramming or overerasing due to program runaway, etc.

Use the recommended algorithm when programming and erasing flash memory: The recommended algorithm enables programming and erasing to be carried out without subjecting the device to voltage stress or sacrificing program data reliability. When setting the P or E bit in FLMCR1, the watchdog timer should be set beforehand as a precaution against program runaway, etc.

Do not set or clear the SWE bit during execution of a program in flash memory: Wait for at least 100 μ s after clearing the SWE bit before executing a program or reading data in flash memory. When the SWE bit is set, data in flash memory can be rewritten, but when $SWE = 1$, flash memory can only be read in program-verify or erase-verify mode. Access flash memory only for verify operations (verification during programming/erasing). Also, do not clear the SWE bit during programming, erasing, or verifying.

Similarly, when using the RAM emulation function while a high level is being input to the FWE pin, the SWE bit must be cleared before executing a program or reading data in flash memory.

However, the RAM area overlapping flash memory space can be read and written to regardless of whether the SWE bit is set or cleared.

Do not use interrupts while flash memory is being programmed or erased: All interrupt requests, including NMI, should be disabled during FWE application to give priority to program/erase operations.

Do not perform additional programming. Erase the memory before reprogramming: In on-board programming, perform only one programming operation on a 128-byte programming unit block. In programmer mode, too, perform only one programming operation on a 128-byte programming unit block. Programming should be carried out with the entire programming unit block erased.

Before programming, check that the chip is correctly mounted in the PROM programmer: Overcurrent damage to the device can result if the index marks on the PROM programmer socket, socket adapter, and chip are not correctly aligned.

Do not touch the socket adapter or chip during programming: Touching either of these can cause contact faults and write errors.

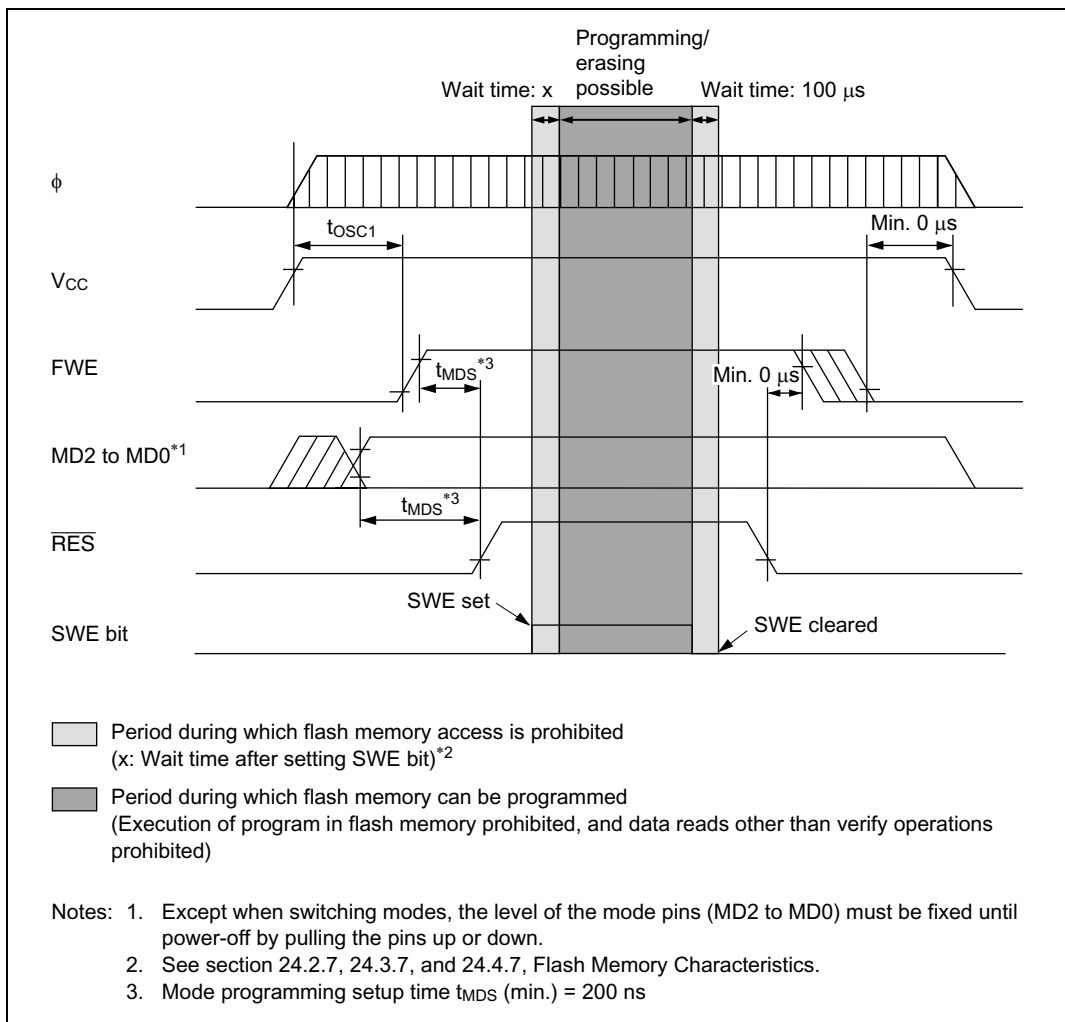

Figure 21B-26 Power-On/Off Timing (Boot Mode)

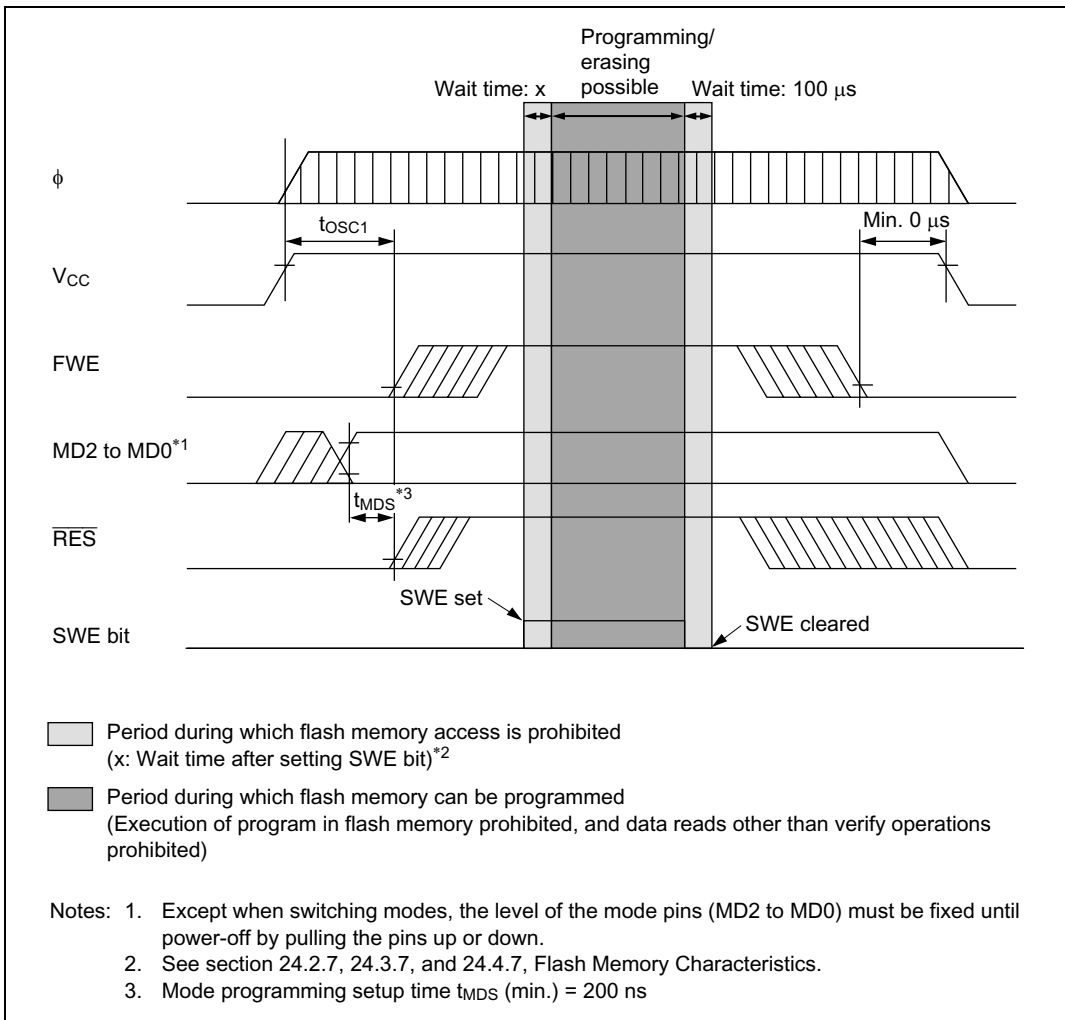

Figure 21B-27 Power-On/Off Timing (User Program Mode)

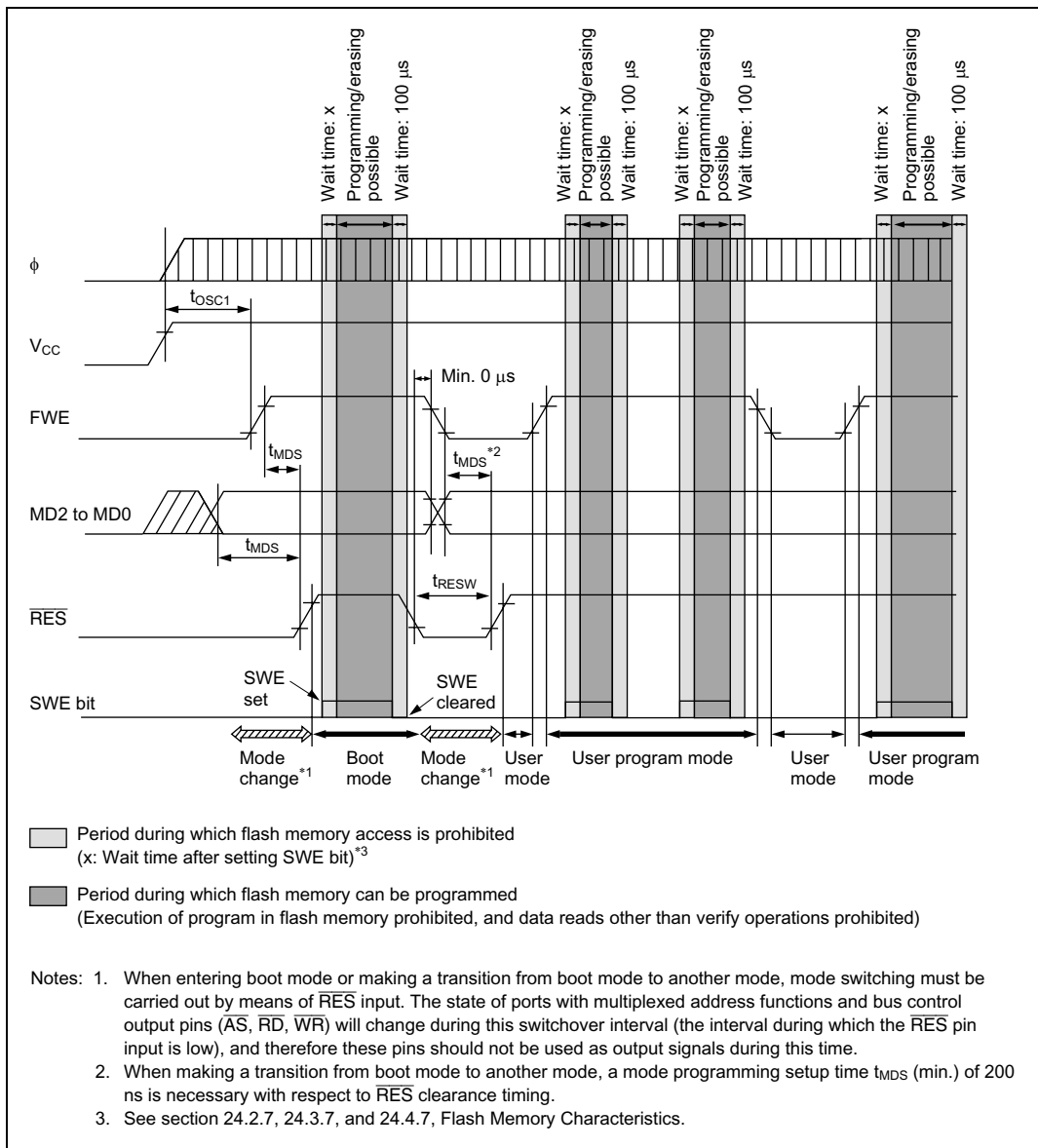

Figure 21B-28 Mode Transition Timing
(Example: Boot Mode → User Mode ↔ User Program Mode)

21B.16 Note on Switching from F-ZTAT Version to Mask ROM Version

The mask ROM version does not have the internal registers for flash memory control that are provided in the F-ZTAT version. Table 21B-24 lists the registers that are present in the F-ZTAT version but not in the mask ROM version. If a register listed in table 21B-24 is read in the mask ROM version, an undefined value will be returned. Therefore, if application software developed on the F-ZTAT version is switched to a mask ROM version product, it must be modified to ensure that the registers in table 21B-27 have no effect.

Table 21B-27 Registers Present in F-ZTAT Version but Absent in Mask ROM Version

Register	Abbreviation	Address
Flash memory control register 1	FLMCR1	H'FFA8
Flash memory control register 2	FLMCR2	H'FFA9
Erase block register 1	EBR1	H'FFAA
Erase block register 2	EBR2	H'FFAB
RAM emulation register	RAMER	H'FEDB

Section 21C ROM (H8S/2635 Group)

21C.1 Overview

The H8S/2635 Group has 192 kbytes of on-chip flash memory, or 192 kbytes or 128 kbytes of on-chip mask ROM. The ROM is connected to the bus master via a 16-bit data bus, enabling both byte and word data to be accessed in one state. Instruction fetching is thus speeded up, and processing speed increased.

The on-chip ROM is enabled and disabled by setting the mode pins (MD2 to MD0).

The flash memory version can be erased and programmed on-board, as well as with a special-purpose PROM programmer.

21C.1.1 Block Diagram

Figure 21C-1 shows a block diagram of 192-kbyte and 128-kbyte ROM.

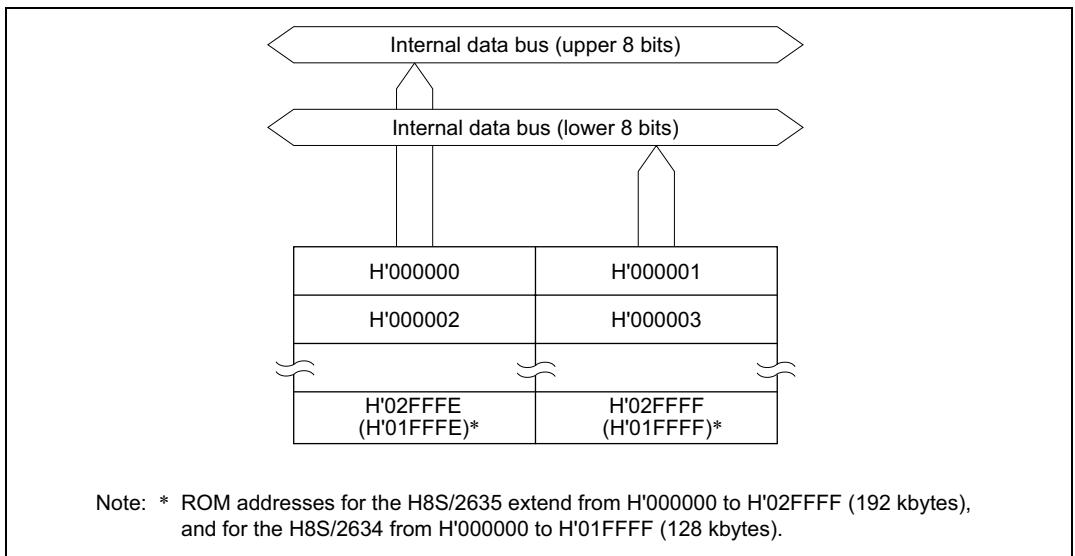

Figure 21C-1 Block Diagram of ROM 192 kbytes (128 kbytes)*

21C.1.2 Register Configuration

The H8S/2638 and H8S/2639 operating mode is controlled by the mode pins and the MDCR register. The register configuration is shown in table 21C-1.

Table 21C-1 Register Configuration

Register Name	Abbreviation	R/W	Initial Value	Address*
Mode control register	MDCR	R/W	Undefined	H'FDE7

Note: * Lower 16 bits of the address.

21C.2 Register Descriptions

21C.2.1 Mode Control Register (MDCR)

Bit:	7	6	5	4	3	2	1	0
	—	—	—	—	—	MDS2	MDS1	MDS0
Initial value:	1	0	0	0	0	—*	—*	—*
R/W:	R/W	—	—	—	—	R	R	R

Note: * Determined by pins MD2 to MD0.

MDCR is an 8-bit register used to monitor the current H8S/2638 Group, H8S/2639 Group, and H8S/2630 Group operating mode.

Bit 7—Reserved: Only 1 should be written to these bits.

Bits 6 to 3—Reserved: These bits are always read as 0 and cannot be modified.

Bits 2 to 0—Mode Select 2 to 0 (MDS2 to MDS0): These bits indicate the input levels at pins MD2 to MD0 (the current operating mode). Bits MDS2 to MDS0 correspond to pins MD2 to MD0. MDS2 to MDS0 are read-only bits, and cannot be modified. The mode pin (MD2 to MD0) input levels are latched into these bits when MDCR is read. These latches are canceled by a reset.

21C.3 Operation

The on-chip ROM is connected to the CPU by a 16-bit data bus, and both byte and word data can be accessed in one state. Even addresses are connected to the upper 8 bits, and odd addresses to the lower 8 bits. Word data must start at an even address.

The on-chip ROM is enabled and disabled by setting the mode pins (MD2, MD1, and MD0). These settings are shown in table 21C-2.

Table 21C-2 Operating Modes and ROM (F-ZTAT Version)

Operating Mode		Mode Pins				On-Chip ROM
		FWE	MD2	MD1	MD0	
Mode 0	—	0	0	0	0	—
Mode 1					1	
Mode 2				1	0	
Mode 3					1	
Mode 4	Advanced expanded mode with on-chip ROM disabled	1	0	0		Disabled
Mode 5	Advanced expanded mode with on-chip ROM disabled				1	
Mode 6	Advanced expanded mode with on-chip ROM enabled			1	0	Enabled (192 kbytes/ 128 kbytes)* ³
Mode 7	Advanced single-chip mode				1	Enabled (192 kbytes/ 128 kbytes)* ³
Mode 8	—	1	0	0	0	—
Mode 9					1	
Mode 10	Boot mode (advanced expanded mode with on-chip ROM enabled)* ¹			1	0	Enabled (192 kbytes/ 128 kbytes)* ³
Mode 11	Boot mode (advanced single-chip mode)* ²				1	Enabled (192 kbytes/ 128 kbytes)* ³
Mode 12	—	1	0	0	0	—
Mode 13					1	
Mode 14	User program mode (advanced expanded mode with on-chip ROM enabled)* ¹			1	0	Enabled (192 kbytes/ 128 kbytes)* ³
Mode 15	User program mode (advanced single-chip mode)* ²				1	Enabled (192 kbytes/ 128 kbytes)* ³

Notes: 1. Apart from the fact that flash memory can be erased and programmed, operation is the same as in advanced expanded mode with on-chip ROM enabled.

2. Apart from the fact that flash memory can be erased and programmed, operation is the same as in advanced single-chip mode.

3. The H8S/2635 has 192 kbytes of on-chip ROM. The H8S/2634 has 128 kbytes of on-chip ROM.

Table 21C-3 Operating Modes and ROM (Mask ROM Version)

Operating Mode	Mode Pins			On-Chip ROM	
	MD2	MD1	MD0		
Mode 0	—	0	0	—	
Mode 1			1		
Mode 2		1	0		
Mode 3			1		
Mode 4	Advanced expanded mode with on-chip ROM disabled	1	0	0	Disabled
Mode 5	Advanced expanded mode with on-chip ROM disabled			1	
Mode 6	Advanced expanded mode with on-chip ROM enabled		1	0	Enabled (192 kbytes/ 128 kbytes)*
Mode 7	Advanced single-chip mode			1	Enabled (192 kbytes/ 128 kbytes)*

Note: * The H8S/2635 has 192 kbytes of on-chip ROM. The H8S/2634 has 128 kbytes of on-chip ROM.

21C.4 Flash Memory Overview

21C.4.1 Features

The H8S/2635 has 192 kbytes of on-chip flash memory, or 192 kbytes or 128 kbytes of on-chip mask ROM. The features of the flash memory are summarized below.

- Four flash memory operating modes
 - Program mode
 - Erase mode
 - Program-verify mode
 - Erase-verify mode
- Programming/erase methods

The flash memory is programmed 128 bytes at a time. Block erase (in single-block units) can be performed. To erase the entire flash memory, each block must be erased in turn. Block erasing can be performed as required on 4 kbytes, 32 kbytes, and 64 kbytes blocks.
- Programming/erase times

The flash memory programming time is 10 ms (typ.) for simultaneous 128-byte programming, equivalent to 80 μ s (typ.) per byte, and the erase time is 100 ms (typ.).
- Reprogramming capability

The flash memory can be reprogrammed up to 100 times.
- On-board programming modes

There are two modes in which flash memory can be programmed/erased/verified on-board:

 - Boot mode
 - User program mode
- Automatic bit rate adjustment

With data transfer in boot mode, the LSI's bit rate can be automatically adjusted to match the transfer bit rate of the host.
- Flash memory emulation in RAM

Flash memory programming can be emulated in real time by overlapping a part of RAM onto flash memory.
- Protect modes

There are three protect modes, hardware, software, and error protection, which allow protected status to be designated for flash memory program/erase/verify operations.

- Programmer mode

Flash memory can be programmed/erased in programmer mode, using a PROM programmer, as well as in on-board programming mode.

21C.4.2 Block Diagram

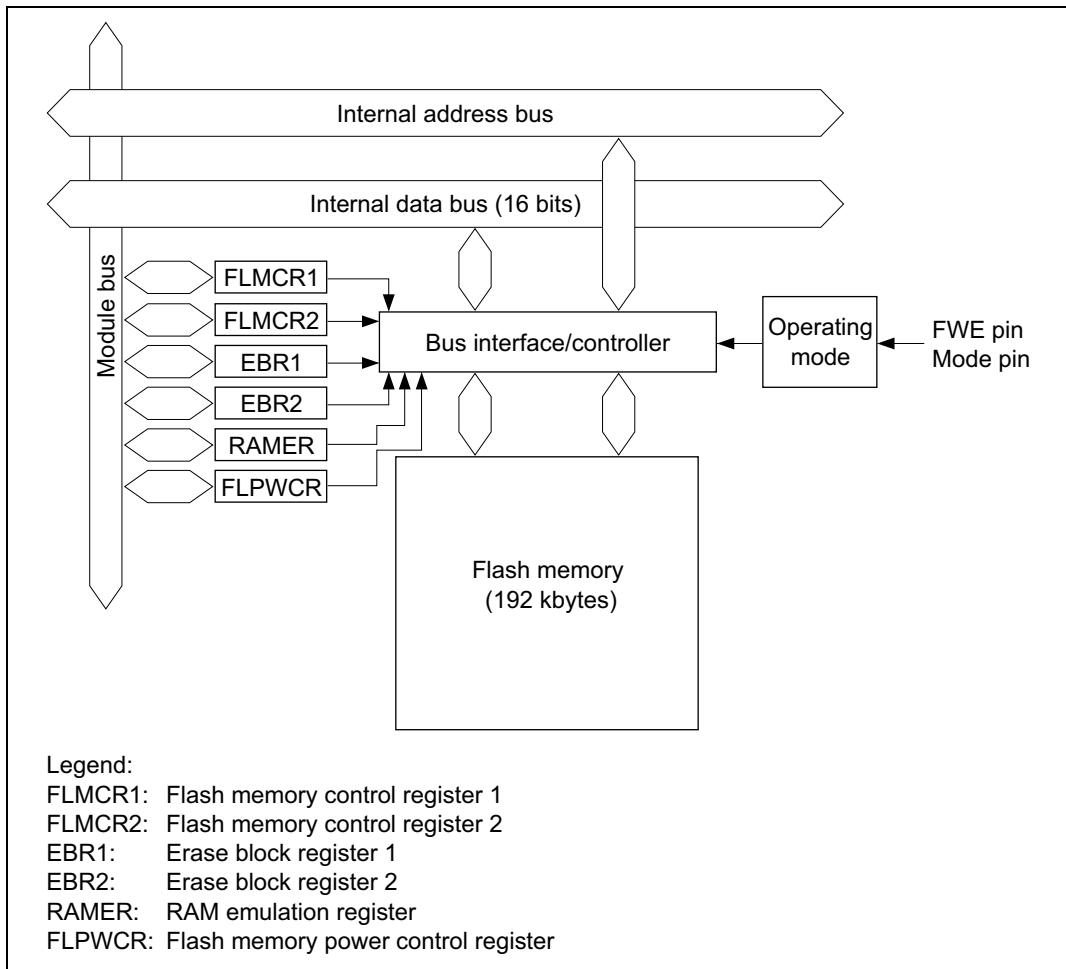

Figure 21C-2 Block Diagram of Flash Memory

21C.4.3 Mode Transitions

When the mode pins and the FWE pin are set in the reset state and a reset-start is executed, the microcomputer enters an operating mode as shown in figure 21C-3. In user mode, flash memory can be read but not programmed or erased.

The boot, user program and programmer modes are provided as modes to write and erase the flash memory.

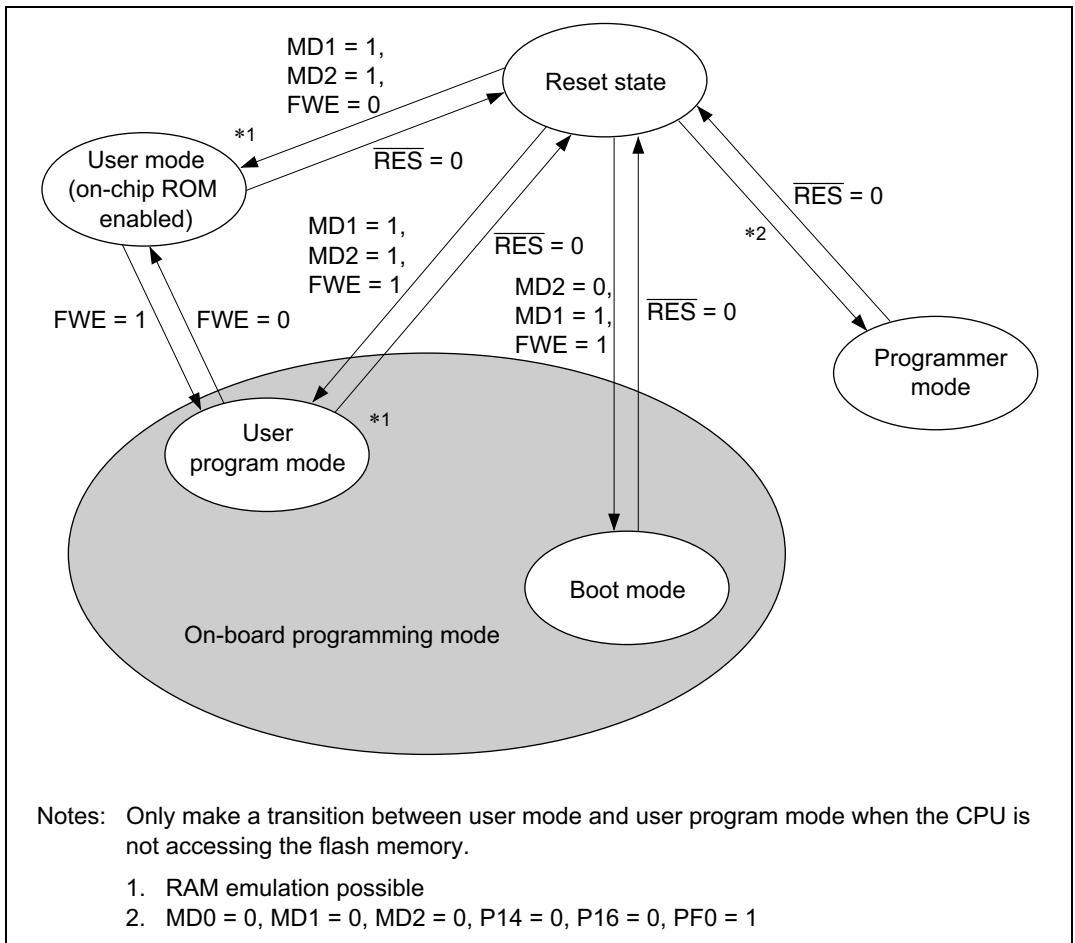

Figure 21C-3 Flash Memory State Transitions

21C.4.4 On-Board Programming Modes

Boot Mode

1. Initial state

The old program version or data remains written in the flash memory. The user should prepare the programming control program and new application program beforehand in the host.

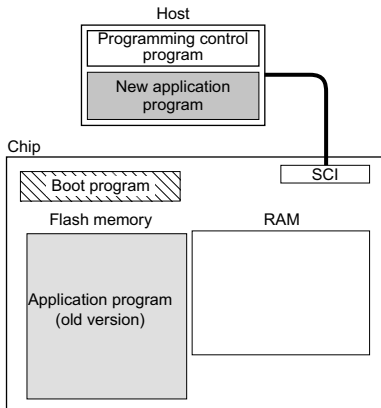

2. Programming control program transfer

When boot mode is entered, the boot program in the chip (originally incorporated in the chip) is started and the programming control program in the host is transferred to RAM via SCI communication. The boot program required for flash memory erasing is automatically transferred to the RAM boot program area.

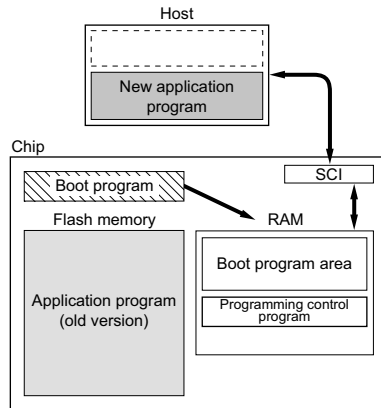

3. Flash memory initialization

The erase program in the boot program area (in RAM) is executed, and the flash memory is initialized (to H'FF). In boot mode, total flash memory erasure is performed, without regard to blocks.

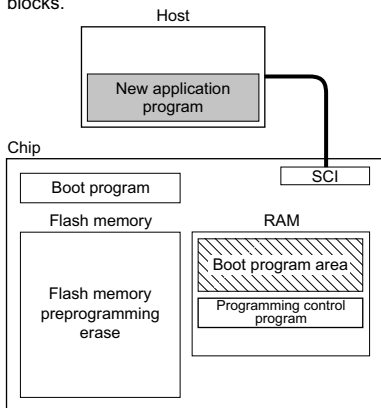

4. Writing new application program

The programming control program transferred from the host to RAM is executed, and the new application program in the host is written into the flash memory.

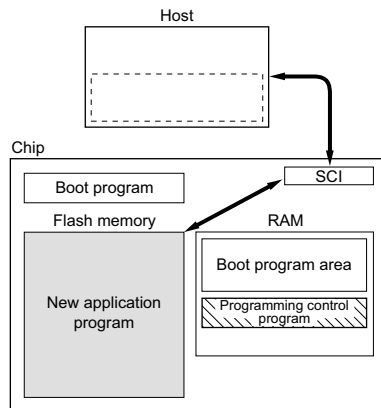

 Program execution state

User Program Mode

1. Initial state

The FWE assessment program that confirms that user program mode has been entered, and the program that will transfer the programming/erase control program from flash memory to on-chip RAM should be written into the flash memory by the user beforehand. The programming/erase control program should be prepared in the host or in the flash memory.

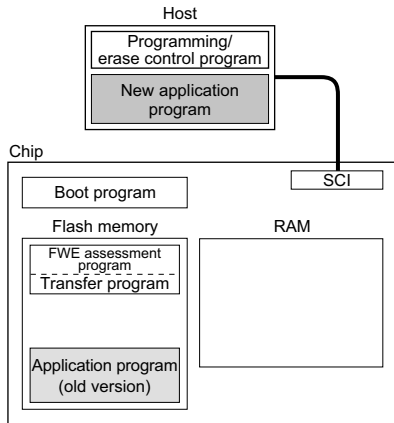

- ### 2. Programming/erase control program transfer
- When user program mode is entered, user software confirms this fact, executes transfer program in the flash memory, and transfers the programming/erase control program to RAM.

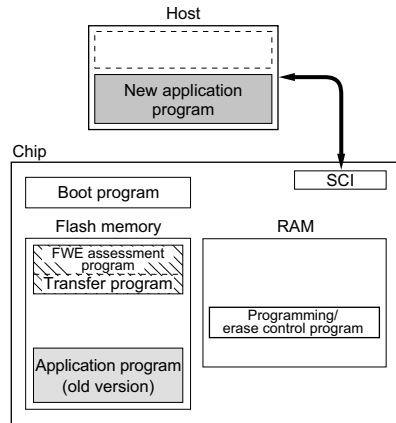

3. Flash memory initialization

The programming/erase program in RAM is executed, and the flash memory is initialized (to H'FF). Erasing can be performed in block units, but not in byte units.

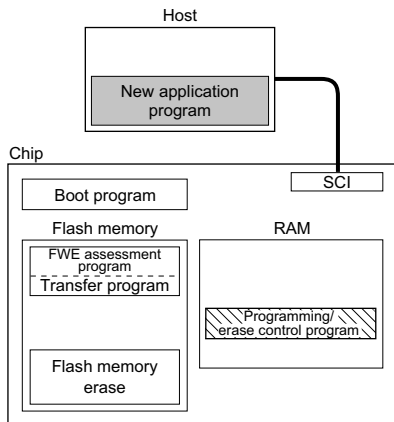

4. Writing new application program

Next, the new application program in the host is written into the erased flash memory blocks. Do not write to unerased blocks.

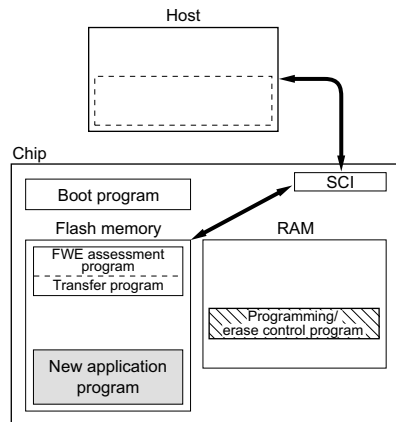

 Program execution state

21C.4.5 Flash Memory Emulation in RAM

Emulation should be performed in user mode or user program mode. When the emulation block set in RAMER is accessed while the emulation function is being executed, data written in the overlap RAM is read.

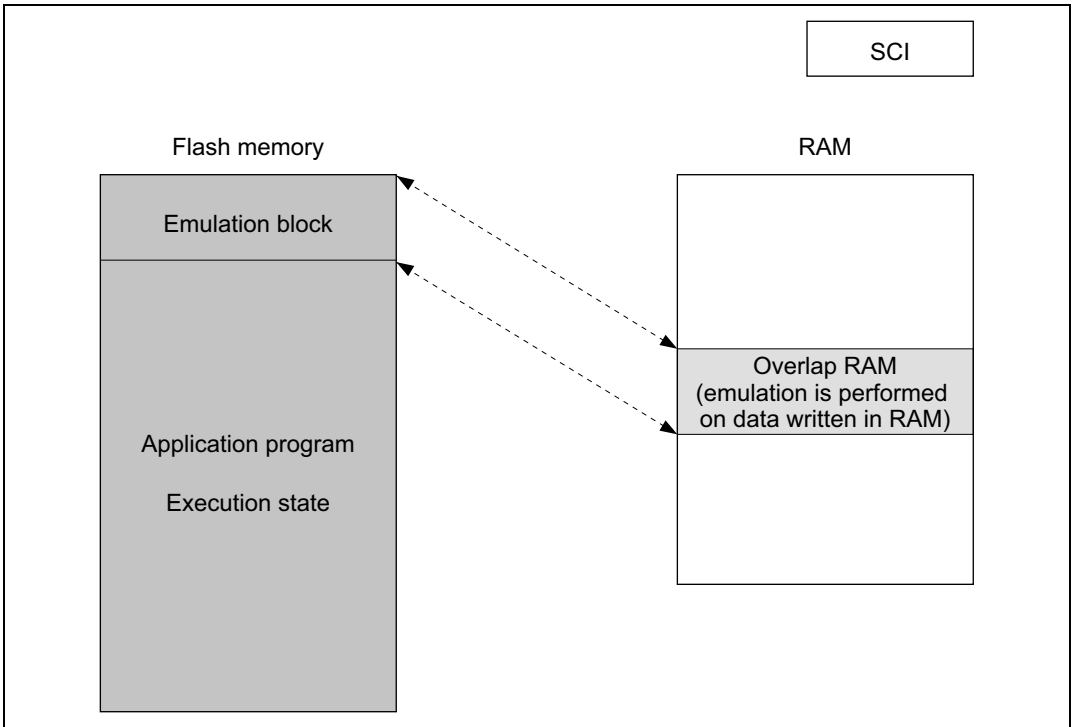

Figure 21C-4 Reading Overlap RAM Data in User Mode or User Program Mode

When overlap RAM data is confirmed, the RAMS bit is cleared, RAM overlap is released, and writes should actually be performed to the flash memory.

When the programming control program is transferred to RAM, ensure that the transfer destination and the overlap RAM do not overlap, as this will cause data in the overlap RAM to be rewritten.

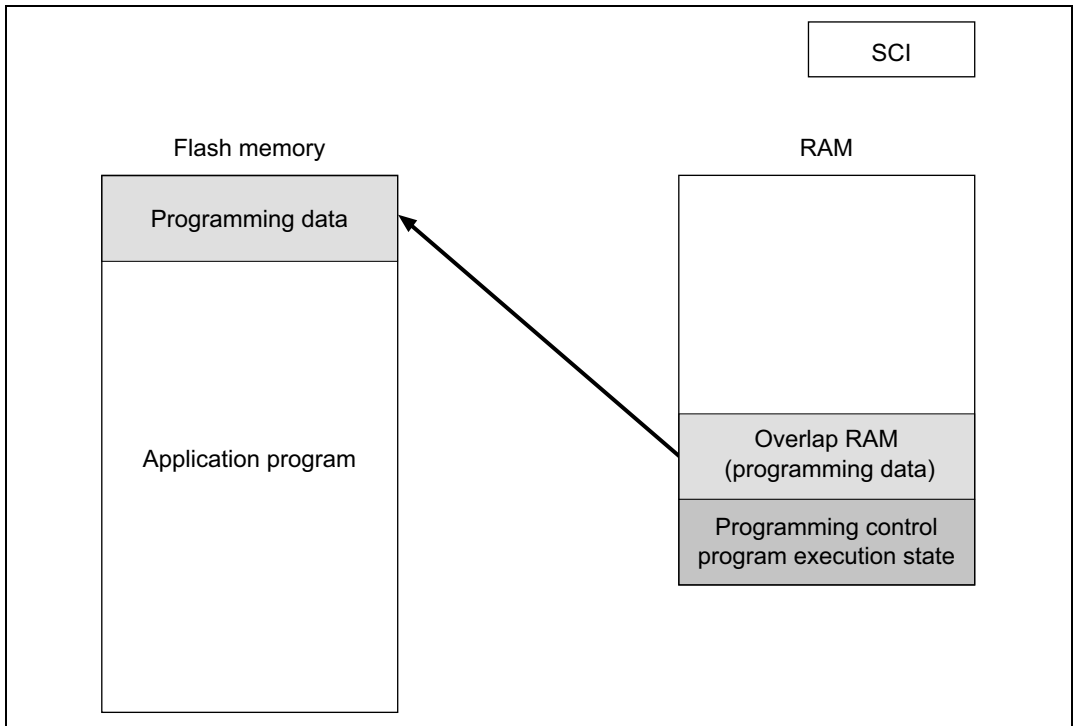

Figure 21C-5 Writing Overlap RAM Data in User Program Mode

21C.4.6 Differences between Boot Mode and User Program Mode

Table 21C-4 Differences between Boot Mode and User Program Mode

	Boot Mode	User Program Mode
Total erase	Yes	Yes
Block erase	No	Yes
Programming control program*	Program/program-verify	Erase/erase-verify Program/program-verify Emulation

Note: * To be provided by the user, in accordance with the recommended algorithm.

21C.4.7 Block Configuration

The H8S/2635 has 192 kbytes of flash memory, which is divided into two 64-kbyte blocks, one 32-kbyte block, and eight 4-kbyte blocks.

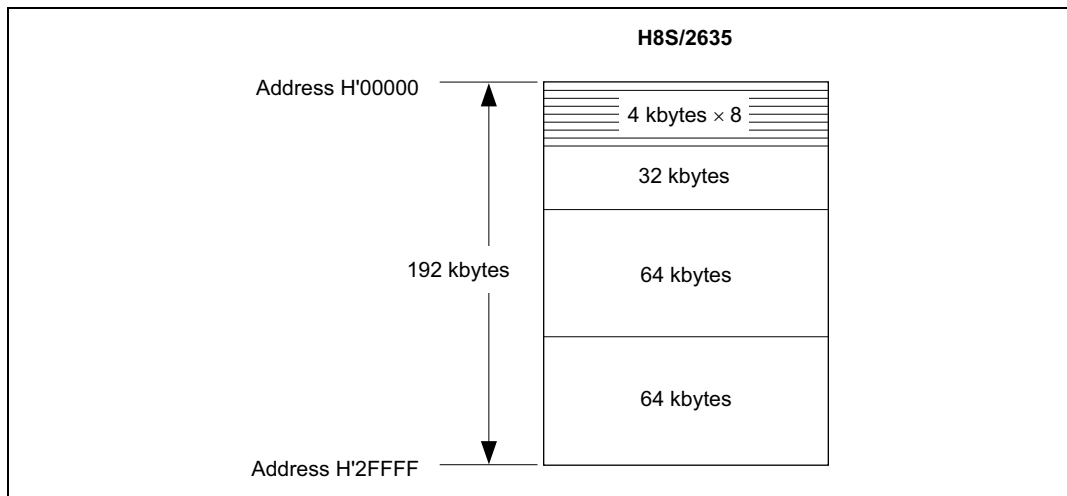

Figure 21C-6 Flash Memory Block Configuration

21C.5 Pin Configuration

The flash memory is controlled by means of the pins shown in table 21C-5.

Table 21C-5 Pin Configuration

Pin Name	Abbreviation	I/O	Function
Reset	$\overline{\text{RES}}$	Input	Reset
Flash write enable	FWE	Input	Flash memory program/erase protection by hardware
Mode 2	MD2	Input	Sets MCU operating mode
Mode 1	MD1	Input	Sets MCU operating mode
Mode 0	MD0	Input	Sets MCU operating mode
Port F0	PF0	Input	Sets MCU operating mode in programmer mode
Port 16	P16	Input	Sets MCU operating mode in programmer mode
Port 14	P14	Input	Sets MCU operating mode in programmer mode
Transmit data	TxD1	Output	Serial transmit data output
Receive data	RxD1	Input	Serial receive data input

21C.6 Register Configuration

The registers used to control the on-chip flash memory when enabled are shown in table 21C-6.

Table 21C-6 Register Configuration

Register Name	Abbreviation	R/W	Initial Value	Address ^{*1}
Flash memory control register 1	FLMCR1 ^{*4}	R/W	H'00 ^{*2}	H'FFA8
Flash memory control register 2	FLMCR2 ^{*4}	R	H'00	H'FFA9
Erase block register 1	EBR1 ^{*4}	R/W	H'00 ^{*3}	H'FFAA
Erase block register 2	EBR2 ^{*4}	R/W	H'00 ^{*3}	H'FFAB
RAM emulation register	RAMER ^{*4}	R/W	H'00	H'FEDB
Flash memory power control register	FLPWCR ^{*4}	R/W	H'00 ^{*3}	H'FFAC

Notes: 1. Lower 16 bits of the address.

2. When a high level is input to the FWE pin, the initial value is H'80.

3. When a low level is input to the FWE pin, or if a high level is input and the SWE1 bit in FLMCR1 is not set, these registers are initialized to H'00.

4. FLMCR1, FLMCR2, EBR1, and EBR2, RAMER, and FLPWCR are 8-bit registers.
Use byte access on these registers.

21C.7 Register Descriptions

21C.7.1 Flash Memory Control Register 1 (FLMCR1)

FLMCR1 is an 8-bit register used for flash memory operating mode control. Program-verify mode or erase-verify mode for on-chip flash memory is entered by setting SWE bit to 1 when FWE = 1, then setting the PV or EV bit. Program mode for on-chip flash memory is entered by setting SWE bit to 1 when FWE = 1, then setting the PSU bit, and finally setting the P bit. Erase mode for on-chip flash memory is entered by setting SWE bit to 1 when FWE = 1, then setting the ESU bit, and finally setting the E bit. FLMCR1 is initialized by a reset, and in hardware standby mode and software standby mode. Its initial value is H'80 when a high level is input to the FWE pin, and H'00 when a low level is input. When on-chip flash memory is disabled, a read will return H'00, and writes are invalid.

Writes are enabled only in the following cases: Writes to bit SWE of FLMCR1 enabled when FWE = 1, to bits ESU, PSU, EV, and PV when FWE = 1 and SWE = 1, to bit E when FWE = 1, SWE = 1 and ESU = 1, and to bit P when FWE = 1, SWE = 1, and PSU = 1.

Bit:	7	6	5	4	3	2	1	0
	FWE	SWE	ESU	PSU	EV	PV	E	P
Initial value:	—*	0	0	0	0	0	0	0
R/W:	R	R/W	R/W	R/W	R/W	R/W	R/W	R/W

Note: * Determined by the state of the FWE pin.

Bit 7—Flash Write Enable Bit (FWE): Sets hardware protection against flash memory programming/erasing.

Bit 7

FWE	Description
0	When a low level is input to the FWE pin (hardware-protected state)
1	When a high level is input to the FWE pin

Bit 6—Software Write Enable Bit (SWE): This bit selects write and erase valid/invalid of the flash memory. Set it when setting bits 5 to 0, bits 7 to 0 of EBR1, and bits 2 to 0 of EBR2.

Bit 6

SWE	Description
0	Writes disabled (Initial value)
1	Writes enabled [Setting condition] <ul style="list-style-type: none"> When FWE = 1

Bit 5—Erase Setup Bit (ESU): Prepares for a transition to erase mode. Set this bit to 1 before setting the E bit in FLMCR1 to 1. Do not set the SWE, PSU, EV, PV, E, or P bit at the same time.

Bit 5

ESU	Description
0	Erase setup cleared (Initial value)
1	Erase setup [Setting condition] <ul style="list-style-type: none"> When FWE = 1 and SWE = 1

Bit 4—Program Setup Bit (PSU): Prepares for a transition to program mode. Set this bit to 1 before setting the P bit in FLMCR1 to 1. Do not set the SWE, ESU, EV, PV, E, or P bit at the same time.

Bit 4

PSU	Description
0	Program setup cleared (Initial value)
1	Program setup [Setting condition] <ul style="list-style-type: none"> When FWE = 1 and SWE = 1

Bit 3—Erase-Verify (EV): Selects erase-verify mode transition or clearing. Do not set the SWE, ESU, PSU, PV, E, or P bit at the same time.

Bit 3

EV	Description
0	Erase-verify mode cleared (Initial value)
1	Transition to erase-verify mode [Setting condition] <ul style="list-style-type: none"> When FWE = 1 and SWE = 1

Bit 2—Program-Verify (PV): Selects program-verify mode transition or clearing. Do not set the SWE, ESU, PSU, EV, E, or P bit at the same time.

Bit 2

PV	Description
0	Program-verify mode cleared (Initial value)
1	Transition to program-verify mode [Setting condition] <ul style="list-style-type: none"> When FWE = 1 and SWE = 1

Bit 1—Erase (E): Selects erase mode transition or clearing. Do not set the SWE, ESU, PSU, EV, PV, or P bit at the same time.

Bit 1

E	Description
0	Erase mode cleared (Initial value)
1	Transition to erase mode [Setting condition] <ul style="list-style-type: none"> When FWE = 1, SWE = 1, and ESU = 1

Bit 0—Program (P): Selects program mode transition or clearing. Do not set the SWE, PSU, ESU, EV, PV, or E bit at the same time.

Bit 0

P	Description
0	Program mode cleared (Initial value)
1	Transition to program mode [Setting condition] <ul style="list-style-type: none"> When FWE = 1, SWE = 1, and PSU = 1

21C.7.2 Flash Memory Control Register 2 (FLMCR2)

FLMCR2 is an 8-bit register used for flash memory operating mode control. FLMCR2 is initialized to H'00 by a reset, and in hardware standby mode and software standby mode. When on-chip flash memory is disabled, a read will return H'00.

Bit:	7	6	5	4	3	2	1	0
	FLER	—	—	—	—	—	—	—
Initial value:	0	0	0	0	0	0	0	0
R/W:	R	—	—	—	—	—	—	—

Note: FLMCR2 is a read-only register, and should not be written to.

Bit 7—Flash Memory Error (FLER): Indicates that an error has occurred during an operation on flash memory (programming or erasing). When FLER is set to 1, flash memory goes to the error-protection state.

Bit 7

FLER	Description
0	Flash memory is operating normally (Initial value) Flash memory program/erase protection (error protection) is disabled [Clearing condition] <ul style="list-style-type: none"> Reset or hardware standby mode
1	An error has occurred during flash memory programming/erasing Flash memory program/erase protection (error protection) is enabled [Setting condition] <ul style="list-style-type: none"> See section 21C.10.3, Error Protection

Bits 6 to 0—Reserved: These bits always read 0.

21C.7.3 Erase Block Register 1 (EBR1)

EBR1 is an 8-bit register that specifies the flash memory erase area block by block. EBR1 is initialized to H'00 by a reset, in hardware standby mode and software standby mode, when a low level is input to the FWE pin, and when a high level is input to the FWE pin and the SWE bit in FLMCR1 is not set. When a bit in EBR1 is set to 1, the corresponding block can be erased. Other blocks are erase-protected. Only one of the bits of EBR1 and EBR2 combined can be set. Do not set more than one bit, as this will cause all the bits in both EBR1 and EBR2 to be automatically cleared to 0. When on-chip flash memory is disabled, a read will return H'00, and writes are invalid.

The flash memory erase block configuration is shown in table 21C-7.

Bit:	7	6	5	4	3	2	1	0
	EB7	EB6	EB5	EB4	EB3	EB2	EB1	EB0
Initial value:	0	0	0	0	0	0	0	0
R/W:	R/W	R/W	R/W	R/W	R/W	R/W	R/W	R/W

21C.7.4 Erase Block Register 2 (EBR2)

EBR2 is an 8-bit register that specifies the flash memory erase area block by block. EBR2 is initialized to H'00 by a reset, in hardware standby mode and software standby mode, when a low level is input to the FWE pin. Bit 0 will be initialized to 0 if bit SWE of FLMCR1 is not set, even though a high level is input to pin FWE. When a bit in EBR2 is set to 1, the corresponding block can be erased. Other blocks are erase-protected. Only one of the bits of EBR1 and EBR2 combined can be set. Do not set more than one bit, as this will cause all the bits in both EBR1 and EBR2 to be automatically cleared to 0. On the H8S/2635 bits 7 to 3 are reserved. Only 0 may be written to these reserved bits. When on-chip flash memory is disabled, a read will return H'00, and writes are invalid.

The flash memory erase block configuration is shown in table 21C-7.

Bit:	7	6	5	4	3	2	1	0
	—	—	—	—	—	EB10	EB9	EB8
Initial value:	0	0	0	0	0	0	0	0
R/W:	R/W	R/W	R/W	R/W	R/W	R/W	R/W	R/W

Note: Bits 7 to 3 are reserved and only 0 may be written to them.

Table 21C-7 Flash Memory Erase Blocks

Block (Size)	Addresses
EB0 (4 kbytes)	H'000000 to H'000FFF
EB1 (4 kbytes)	H'001000 to H'001FFF
EB2 (4 kbytes)	H'002000 to H'002FFF
EB3 (4 kbytes)	H'003000 to H'003FFF
EB4 (4 kbytes)	H'004000 to H'004FFF
EB5 (4 kbytes)	H'005000 to H'005FFF
EB6 (4 kbytes)	H'006000 to H'006FFF
EB7 (4 kbytes)	H'007000 to H'007FFF
EB8 (32 kbytes)	H'008000 to H'00FFFF
EB9 (64 kbytes)	H'010000 to H'01FFFF
EB10 (64 kbytes)	H'020000 to H'02FFFF

21C.7.5 RAM Emulation Register (RAMER)

RAMER specifies the area of flash memory to be overlapped with part of RAM when emulating real-time flash memory programming. RAMER initialized to H'00 by a reset and in hardware standby mode. It is not initialized in software standby mode. RAMER settings should be made in user mode or user program mode.

Flash memory area divisions are shown in table 21C-8. To ensure correct operation of the emulation function, the ROM for which RAM emulation is performed should not be accessed immediately after this register has been modified. Normal execution of an access immediately after register modification is not guaranteed.

Bit:	7	6	5	4	3	2	1	0
	—	—	—	—	RAMS	RAM2	RAM1	RAM0
Initial value:	0	0	0	0	0	0	0	0
R/W:	R	R	R/W	R/W	R/W	R/W	R/W	R/W

Bits 7 and 6—Reserved: These bits always read 0.

Bits 5 and 4—Reserved: Only 0 may be written to these bits.

Bit 3—RAM Select (RAMS): Specifies selection or non-selection of flash memory emulation in RAM. When RAMS = 1, all flash memory block are program/erase-protected.

Bit 3

RAMS	Description
0	Emulation not selected (Initial value) Program/erase-protection of all flash memory blocks is disabled
1	Emulation selected Program/erase-protection of all flash memory blocks is enabled

Bits 2 to 0—Flash Memory Area Selection: These bits are used together with bit 3 to select the flash memory area to be overlapped with RAM. (See table 21C-8.)

Table 21C-8 Flash Memory Area Divisions

Addresses	Block Name	RAMS	RAM1	RAM1	RAM0
H'FFD800 to H'FFE7FF	RAM area 4 kbytes	0	*	*	*
H'000000 to H'000FFF	EB0 (4 kbytes)	1	0	0	0
H'001000 to H'001FFF	EB1 (4 kbytes)	1	0	0	1
H'002000 to H'002FFF	EB2 (4 kbytes)	1	0	1	0
H'003000 to H'003FFF	EB3 (4 kbytes)	1	0	1	1
H'004000 to H'004FFF	EB4 (4 kbytes)	1	1	0	0
H'005000 to H'005FFF	EB5 (4 kbytes)	1	1	0	1
H'006000 to H'006FFF	EB6 (4 kbytes)	1	1	1	0
H'007000 to H'007FFF	EB7 (4 kbytes)	1	1	1	1

*: Don't care

21C.7.6 Flash Memory Power Control Register (FLPWCR)

Bit:	7	6	5	4	3	2	1	0
	PDWND	—	—	—	—	—	—	—
Initial value:	0	0	0	0	0	0	0	0
R/W:	R/W	R	R	R	R	R	R	R

FLPWCR enables or disables a transition to the flash memory power-down mode when the LSI switches to subactive mode.

Bit 7—Power-Down Disable (PDWND): The subactive mode is not available in versions other than the U-mask and W-mask versions.

Only 0 should be written to this bit in the case of versions other than the U-mask and W-mask versions.

See section 21.B.14, Flash Memory and Power-Down States, for more information.

Bit 7

PDWND	Description
0	Transition to flash memory power-down mode enabled (Initial value)
1	Transition to flash memory power-down mode disabled

Bits 6 to 0—Reserved: These bits always read 0.

21C.8 On-Board Programming Modes

When pins are set to on-board programming mode and a reset-start is executed, a transition is made to the on-board programming state in which program/erase/verify operations can be performed on the on-chip flash memory. There are two on-board programming modes: boot mode and user program mode. The pin settings for transition to each of these modes are shown in table 21C-9. For a diagram of the transitions to the various flash memory modes, see figure 21C-3.

Table 21C-9 Setting On-Board Programming Modes

Mode		FWE	MD2	MD1	MD0
Boot mode	Expanded mode	1	0	1	0
	Single-chip mode		0	1	1
User program mode	Expanded mode	1	1	1	0
	Single-chip mode		1	1	1

21C.8.1 Boot Mode

When boot mode is used, the flash memory programming control program must be prepared in the host beforehand. The SCI channel to be used is set to asynchronous mode.

When a reset-start is executed after the H8S/2635 Group's pins have been set to boot mode, the boot program built into the H8S/2635 Group are started and the programming control program prepared in the host is serially transmitted to the H8S/2635 Group via the SCI. In the H8S/2635 Group, the programming control program received via the SCI is written into the programming control program area in on-chip RAM. After the transfer is completed, control branches to the start address of the programming control program area and the programming control program execution state is entered (flash memory programming is performed).

The transferred programming control program must therefore include coding that follows the programming algorithm given later.

The system configuration in boot mode is shown in figure 21C-7, and the boot mode execution procedure in figure 21C-8.

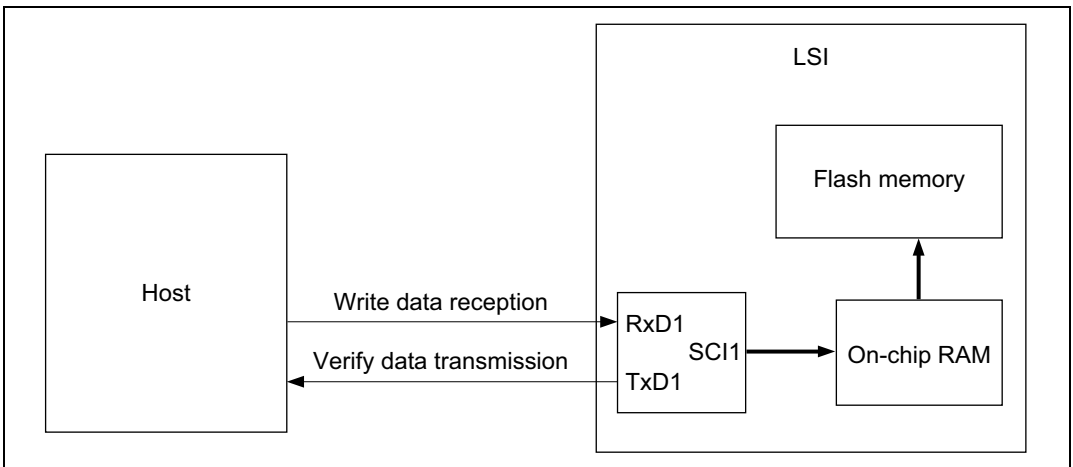

Figure 21C-7 System Configuration in Boot Mode

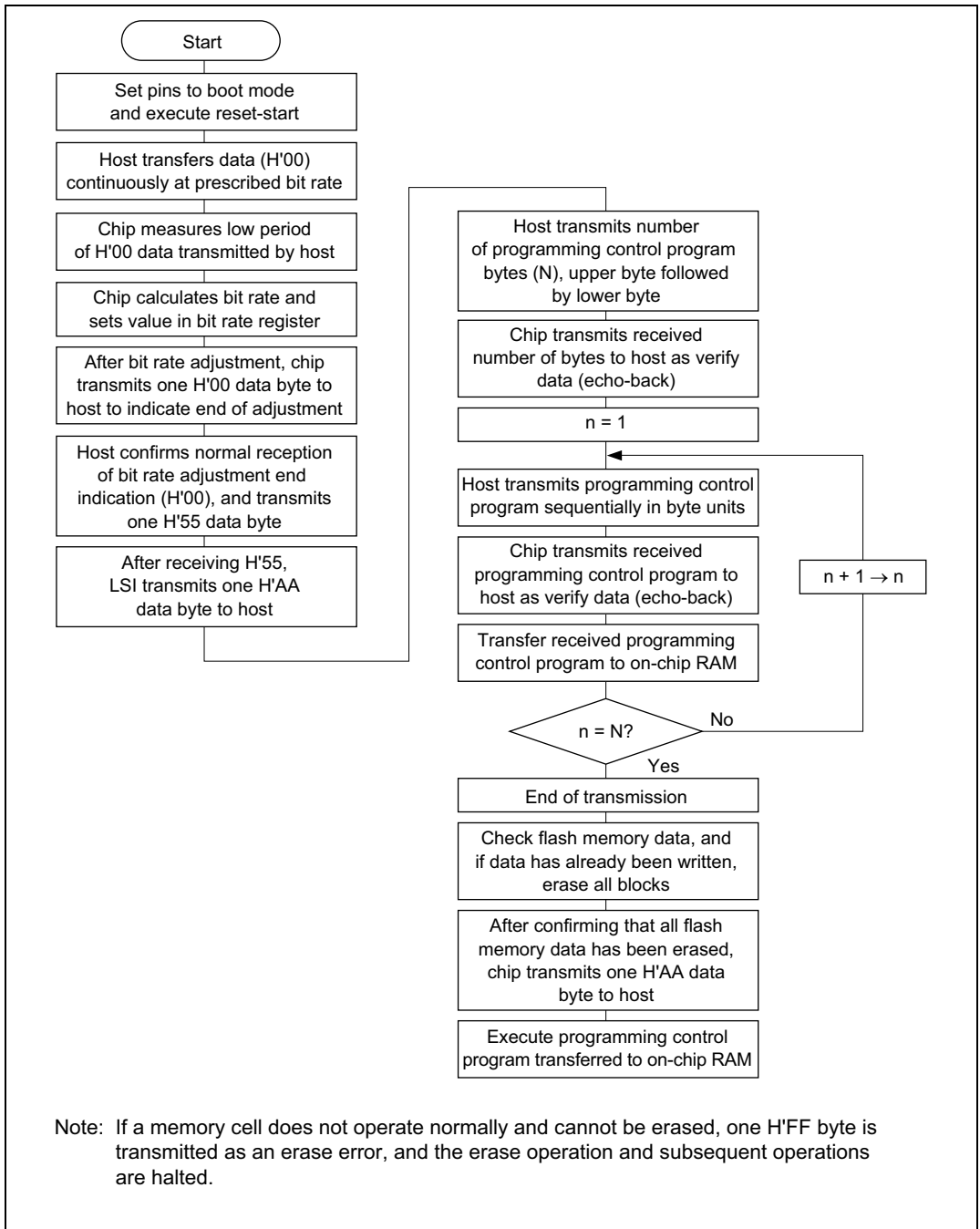
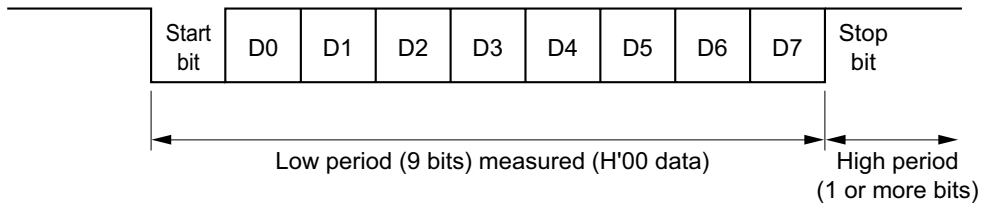

Figure 21C-8 Boot Mode Execution Procedure

Automatic SCI Bit Rate Adjustment



When boot mode is initiated, the LSI measures the low period of the asynchronous SCI communication data (H'00) transmitted continuously from the host. The SCI transmit/receive format should be set as follows: 8-bit data, 1 stop bit, no parity. The LSI calculates the bit rate of the transmission from the host from the measured low period, and transmits one H'00 byte to the host to indicate the end of bit rate adjustment. The host should confirm that this adjustment end indication (H'00) has been received normally, and transmit one H'55 byte to the LSI. If reception cannot be performed normally, initiate boot mode again (reset), and repeat the above operations. Depending on the host's transmission bit rate and the LSI's system clock frequency, there will be a discrepancy between the bit rates of the host and the LSI. Set the host transfer bit rate at 4,800, 9,600 or 19,200 bps to operate the SCI properly.

Table 21C-10 shows host transfer bit rates and system clock frequencies for which automatic adjustment of the LSI bit rate is possible. The boot program should be executed within this system clock range.

Table 21C-10 System Clock Frequencies for which Automatic Adjustment of LSI Bit Rate Is Possible

Host Bit Rate	System Clock Frequency for which Automatic Adjustment of LSI Bit Rate Is Possible
4,800 bps	4 to 20 MHz
9,600 bps	8 to 20 MHz
19,200 bps	16 to 20 MHz

Note: The system clock frequency used in boot mode is generated by an external crystal oscillator element. PLL frequency multiplication is not used.

On-Chip RAM Area Divisions in Boot Mode: In boot mode, the RAM area is divided into an area used by the boot program and an area to which the programming control program is transferred via the SCI, as shown in figure 21C-9. The boot program area cannot be used until the execution state in boot mode switches to the programming control program transferred from the host.

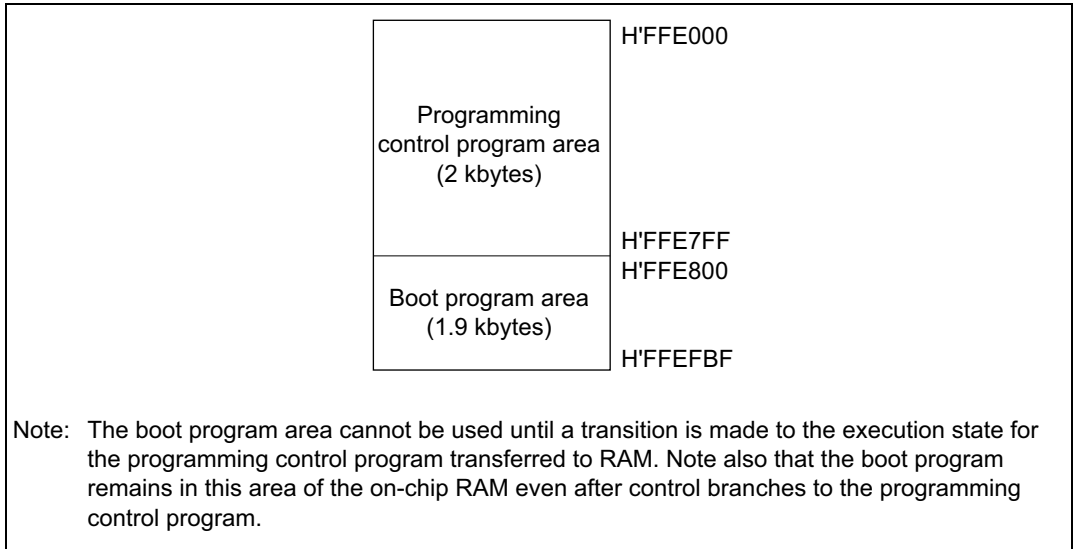

Figure 21C-9 RAM Areas in Boot Mode

Notes on Use of Boot Mode:

- When the chip comes out of reset in boot mode, it measures the low-level period of the input at the SCI's RxD1 pin. The reset should end with RxD1 high. After the reset ends, it takes approximately 100 states before the chip is ready to measure the low-level period of the RxD1 pin.
- In boot mode, if any data has been programmed into the flash memory (if all data is not 1), all flash memory blocks are erased. Boot mode is for use when user program mode is unavailable, such as the first time on-board programming is performed, or if the program activated in user program mode is accidentally erased.
- Interrupts cannot be used while the flash memory is being programmed or erased.
- The RxD1 and TxD1 pins should be pulled up on the board.

- Before branching to the programming control program (RAM area H'FFE000), the chip terminates transmit and receive operations by the on-chip SCI (channel 1) (by clearing the RE and TE bits in SCR to 0), but the adjusted bit rate value remains set in BRR. The transmit data output pin, TxD1, goes to the high-level output state (P33DDR = 1, P33DR = 1).

The contents of the CPU's internal general registers are undefined at this time, so these registers must be initialized immediately after branching to the programming control program. In particular, since the stack pointer (SP) is used implicitly in subroutine calls, etc., a stack area must be specified for use by the programming control program.

The initial values of other on-chip registers are not changed.

- Boot mode can be entered by making the pin settings shown in table 21C-9 and executing a reset-start.

Boot mode can be cleared by driving the reset pin low, waiting at least 20 states, then setting the FWE pin and mode pins, and executing reset release^{*1}. Boot mode can also be cleared by a WDT overflow reset.

Do not change the mode pin input levels in boot mode, and do not drive the FWE pin low while the boot program is being executed or while flash memory is being programmed or erased^{*2}.

- If the mode pin input levels are changed (for example, from low to high) during a reset, the state of ports with multiplexed address functions and bus control output pins (\overline{AS} , \overline{RD} , \overline{HWR}) will change according to the change in the microcomputer's operating mode^{*3}.

Therefore, care must be taken to make pin settings to prevent these pins from becoming output signal pins during a reset, or to prevent collision with signals outside the microcomputer.

- Notes: 1. Mode pin and FWE pin input must satisfy the mode programming setup time ($t_{MDS} = 4$ states) with respect to the reset release timing.
2. For precautions on applying and disconnecting FWE, see section 21C.15, Flash Memory Programming and Erasing Precautions.
3. See Appendix D, Pin States.

21C.8.2 User Program Mode

When set to user program mode, the chip can program and erase its flash memory by executing a user program/erase control program. Therefore, on-board reprogramming of the on-chip flash memory can be carried out by providing on-board means of FWE control and supply of programming data, and storing a program/erase control program in part of the program area as necessary.

To select user program mode, select a mode that enables the on-chip flash memory (mode 6 or 7), and apply a high level to the FWE pin. In this mode, on-chip supporting modules other than flash memory operate as they normally would in modes 6 and 7.

The flash memory itself cannot be read while the SWE bit is set to 1 to perform programming or erasing, so the control program that performs programming and erasing should be run in on-chip RAM or external memory. If the program is to be located in external memory, the instruction for writing to flash memory, and the following instruction, should be placed in on-chip RAM.

Figure 21C-10 shows the procedure for executing the program/erase control program when transferred to on-chip RAM.

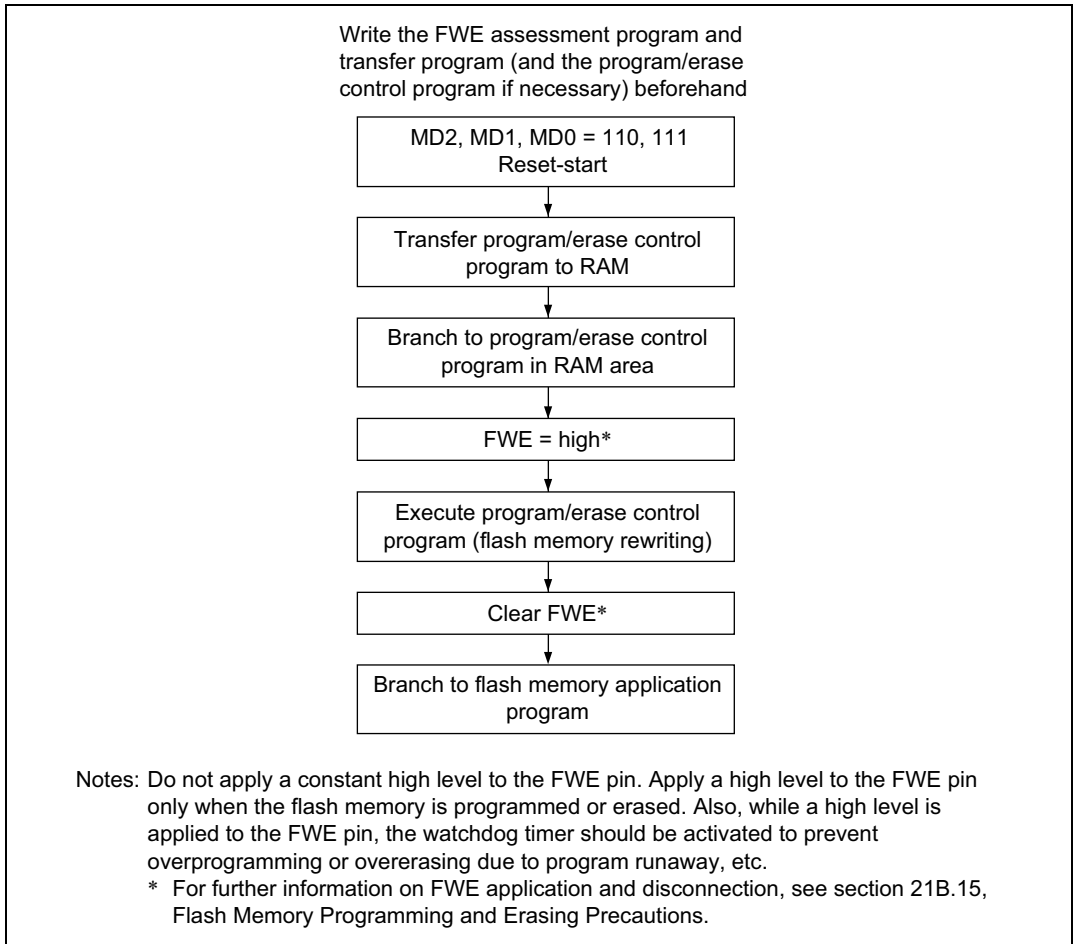

Figure 21C-10 User Program Mode Execution Procedure

21C.9 Programming/Erasing Flash Memory

A software method, using the CPU, is employed to program and erase flash memory in the on-board programming modes. There are four flash memory operating modes: program mode, erase mode, program-verify mode, and erase-verify mode. Transitions to these modes are made by setting the PSU, ESU, P, E, PV, and EV bits in FLMCR1 for on-chip flash memory.

The flash memory cannot be read while it is being written or erased. The flash memory cannot be read while being programmed or erased. Therefore, the program (user program) that controls flash memory programming/erasing should be located and executed in on-chip RAM or external memory. If the program is to be located in external memory, the instruction for writing to flash memory, and the following instruction, should be placed in on-chip RAM. Also ensure that the DTC is not activated before or after execution of the flash memory write instruction.

In the following operation descriptions, wait times after setting or clearing individual bits in FLMCR1 are given as parameters; for details of the wait times, see section 24.2.7 and 24.3.7, Flash Memory Characteristics.

- Notes:
1. Operation is not guaranteed if bits SWE, ESU, PSU, EV, PV, E, and P of FLMCR1 are set/reset by a program in flash memory in the corresponding address areas.
 2. When programming or erasing, set FWE to 1 (programming/erasing will not be executed if FWE = 0).
 3. Programming should be performed in the erased state. Do not perform additional programming on previously programmed addresses.

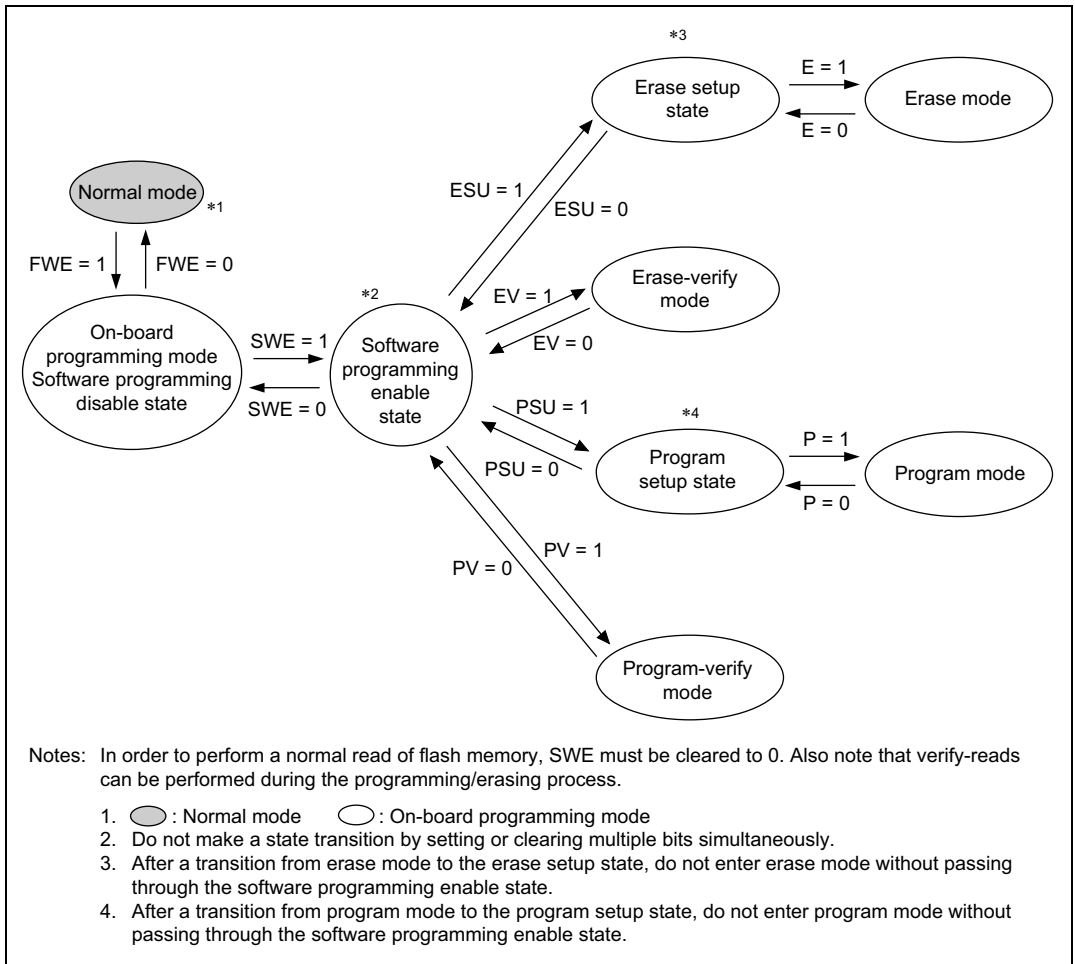

Figure 21C-11 FLMCR1 Bit Settings and State Transitions

21C.9.1 Program Mode

When writing data or programs to flash memory, the program/program-verify flowchart shown in figure 21C-12 should be followed. Performing programming operations according to this flowchart will enable data or programs to be written to flash memory without subjecting the device to voltage stress or sacrificing program data reliability. Programming should be carried out 128 bytes at a time.

The wait times after bits are set or cleared in the flash memory control register 1 (FLMCR1) and the maximum number of programming operations (N) are shown in table 24-22 in section 24.2.7, and in table 24-34 in section 24.3.7, and in table 24-46 in section 24.4.7, Flash Memory Characteristics.

Following the elapse of (t_{sswe}) μ s or more after the SWE bit is set to 1 in FLMCR1, 128-byte data is written consecutively to the write addresses. The lower 8 bits of the first address written to must be H'00 and H'80, 128 consecutive byte data transfers are performed. The program address and program data are latched in the flash memory. A 128-byte data transfer must be performed even if writing fewer than 128 bytes; in this case, H'FF data must be written to the extra addresses.

Next, the watchdog timer (WDT) is set to prevent overprogramming due to program runaway, etc. Set a value greater than ($t_{spsu} + t_{sp} + t_{cp} + t_{cpsu}$) μ s as the WDT overflow period. Preparation for entering program mode (program setup) is performed next by setting the PSU bit in FLMCR1. The operating mode is then switched to program mode by setting the P bit in FLMCR1 after the elapse of at least (t_{spsu}) μ s. The time during which the P bit is set is the flash memory programming time. Make a program setting so that the time for one programming operation is within the range of (t_{sp}) μ s.

The wait time after P bit setting must be changed according to the degree of progress through the programming operation. For details see “Notes on Program/Program-Verify Procedure.”

21C.9.2 Program-Verify Mode

In program-verify mode, the data written in program mode is read to check whether it has been correctly written in the flash memory.

After the elapse of the given programming time, clear the P bit in FLMCR1, then wait for at least (t_{cp}) μ s before clearing the PSU bit to exit program mode. After exiting program mode, the watchdog timer setting is also cleared. The operating mode is then switched to program-verify mode by setting the PV bit in FLMCR1. Before reading in program-verify mode, a dummy write of H'FF data should be made to the addresses to be read. The dummy write should be executed after the elapse of (t_{spv}) μ s or more. When the flash memory is read in this state (verify data is read in 16-bit units), the data at the latched address is read. Wait at least (t_{spvr}) μ s after the dummy write before performing this read operation. Next, the originally written data is compared with the verify data, and reprogram data is computed (see figure 21C-12) and transferred to RAM. After verification of 128 bytes of data has been completed, exit program-verify mode, wait for at least (t_{cpv}) μ s, then clear the SWE bit in FLMCR1. If reprogramming is necessary, set program mode again, and repeat the program/program-verify sequence as before. The maximum number of repetitions of the program/program-verify sequence is indicated by the maximum programming count (N). Leave a wait time of at least (t_{cswe}) μ s after clearing SWE.

Notes on Program/Program-Verify Procedure

1. In order to perform 128-byte-unit programming, the lower 8 bits of the write start address must be H'00 or H'80.
2. When performing continuous writing of 128-byte data to flash memory, byte-unit transfer should be used.
128-byte data transfer is necessary even when writing fewer than 128 bytes of data. Write H'FF data to the extra addresses.
3. Verify data is read in word units.
4. The write pulse is applied and a flash memory write executed while the P bit in FLMCR1 is set. In the chip, write pulses should be applied as follows in the program/program-verify procedure to prevent voltage stress on the device and loss of write data reliability.
 - a. After write pulse application, perform a verify-read in program-verify mode and apply a write pulse again for any bits read as 1 (reprogramming processing). When all the 0-write bits in the 128-byte write data are read as 0 in the verify-read operation, the program/program-verify procedure is completed. In the chip, the number of loops in reprogramming processing is guaranteed not to exceed the maximum value of the maximum programming count (N).

- b. After write pulse application, a verify-read is performed in program-verify mode, and programming is judged to have been completed for bits read as 0. The following processing is necessary for programmed bits.

When programming is completed at an early stage in the program/program-verify procedure:

If programming is completed in the 1st to 6th reprogramming processing loop, additional programming should be performed on the relevant bits. Additional programming should only be performed on bits which first return 0 in a verify-read in certain reprogramming processing.

When programming is completed at a late stage in the program/program-verify procedure:

If programming is completed in the 7th or later reprogramming processing loop, additional programming is not necessary for the relevant bits.

- c. If programming of other bits is incomplete in the 128 bytes, reprogramming processing should be executed. If a bit for which programming has been judged to be completed is read as 1 in a subsequent verify-read, a write pulse should again be applied to that bit.
5. The period for which the P bit in FLMCR1 is set (the write pulse width) should be changed according to the degree of progress through the program/program-verify procedure. For detailed wait time specifications, see section 24.2.7, 24.3.7, and 24.4.7, Flash Memory Characteristics.

Item	Symbol	Item	Symbol
Wait time after P bit setting	t_{sp}	When reprogramming loop count (n) is 1 to 6	t_{sp30}
		When reprogramming loop count (n) is 7 or more	t_{sp200}
		In case of additional programming processing*	t_{sp10}

Note: * Additional programming processing is necessary only when the reprogramming loop count (n) is 1 to 6.

6. The program/program-verify flowchart for the H8S/2638, H8S/2639, and H8S/2630 are shown in figure 21C-12.

To cover the points noted above, bits on which reprogramming processing is to be executed, and bits on which additional programming is to be executed, must be determined as shown below.

Since reprogram data and additional-programming data vary according to the progress of the programming procedure, it is recommended that the following data storage areas (128 bytes each) be provided in RAM.

Reprogram Data Computation Table

(D)	Result of Verify-Read after Write Pulse Application (V)	(X) Result of Operation	Comments
0	0	1	Programming completed: reprogramming processing not to be executed
0	1	0	Programming incomplete: reprogramming processing to be executed
1	0	1	—
1	1	1	Still in erased state: no action

Legend:

(D): Source data of bits on which programming is executed

(X): Source data of bits on which reprogramming is executed

Additional-Programming Data Computation Table

(X')	Result of Verify-Read after Write Pulse Application (V)	(Y) Result of Operation	Comments
0	0	0	Programming by write pulse application judged to be completed: additional programming processing to be executed
0	1	1	Programming by write pulse application incomplete: additional programming processing not to be executed
1	0	1	Programming already completed: additional programming processing not to be executed
1	1	1	Still in erased state: no action

Legend:

(Y): Data of bits on which additional programming is executed

(X'): Data of bits on which reprogramming is executed in a certain reprogramming loop

- It is necessary to execute additional programming processing during the course of the chip program/program-verify procedure. However, once 128-byte-unit programming is finished, additional programming should not be carried out on the same address area. When executing reprogramming, an erase must be executed first. Note that normal operation of reads, etc., is not guaranteed if additional programming is performed on addresses for which a program/program-verify operation has finished.

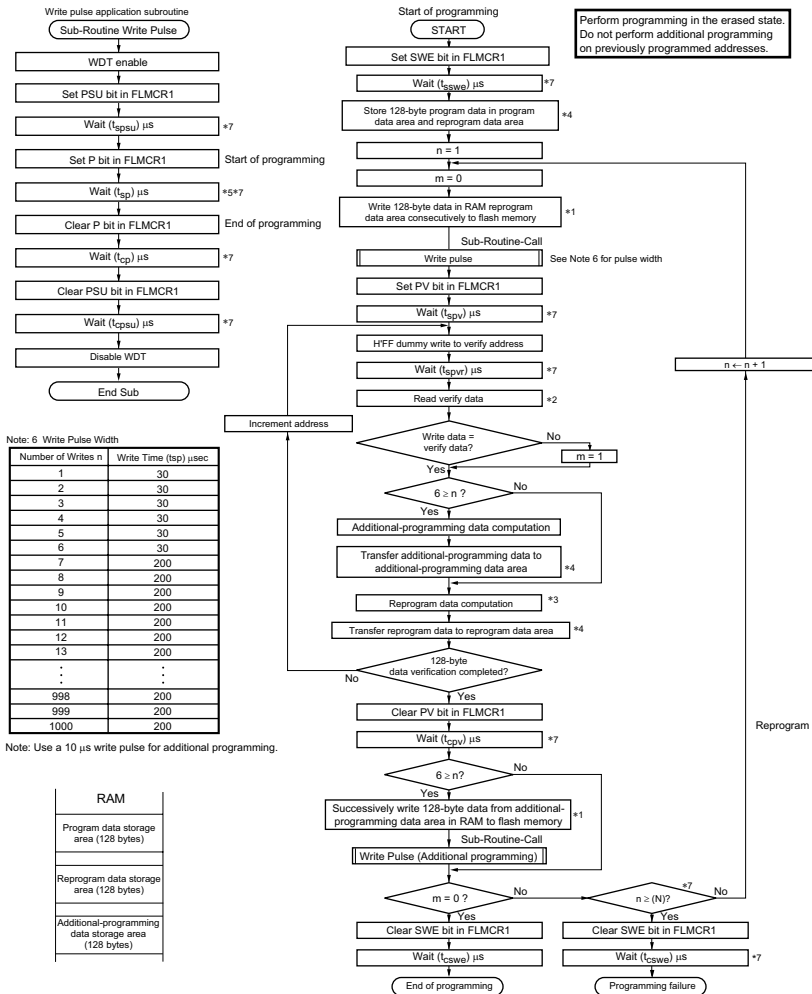

- Notes:
- Data transfer is performed by byte transfer. The lower 8 bits of the first address written to must be H00 or H80. A 128-byte data transfer must be performed even if writing fewer than 128 bytes; in this case, HFF data must be written to the extra addresses.
 - Verify data is read in 16-bit (word) units.
 - Reprogram data is determined by the operation shown in the table below (comparison between the data stored in the program data area and the verify data). Bits for which the reprogram data is 0 are programmed in the next reprogramming loop. Therefore, even bits for which programming has been completed will be subjected to programming once again if the result of the subsequent verify operation is NG.
 - A 128-byte area for storing program data, a 128-byte area for storing reprogram data, and a 128-byte area for storing additional data must be provided in RAM. The contents of the reprogram data area and additional data area are modified as programming proceeds.
 - A write pulse of 30 μs or 200 μs is applied according to the progress of the programming operation. See Note 6 for details of the pulse widths. When writing of additional-programming data is executed, a 10 μs write pulse should be applied. Reprogram data 'X' means reprogram data when the write pulse is applied.
 - The wait times and value of N are shown in section 24.2.7, 24.3.7, and 24.4.7, Flash Memory Characteristics.

Original Data (D)	Verify Data (V)	Reprogram Data (X)	Comments
0	0	1	Programming completed
0	1	0	Programming incomplete; reprogram
1	0	1	
1	1	1	Still in erased state; no action

Reprogram Data (X)	Verify Data (V)	Additional-Programming Data (Y)	Comments
0	0	0	Additional programming to be executed
0	1	1	Additional programming not to be executed
1	0	1	Additional programming not to be executed
1	1	1	Additional programming not to be executed

Figure 21C-12 Program/Program-Verify Flowchart

21C.9.3 Erase Mode

When erasing flash memory, the single-block erase flowchart shown in figure 21C-13 should be followed.

The wait times after bits are set or cleared in the flash memory control register 1 (FLMCR1) and the maximum number of erase operations (N) are shown in table 24-10 in section 24.2.7 and 24.3.7, Flash Memory Characteristics.

To erase flash memory contents, make a 1-bit setting for the flash memory area to be erased in erase block register 1 and 2 (EBR1, EBR2) at least (t_{sswe}) μ s after setting the SWE bit to 1 in FLMCR1. Next, the watchdog timer (WDT) is set to prevent overerasing due to program runaway, etc. Set a value greater than (t_{se}) ms + (t_{sesu} + t_{ce} + t_{cesu}) μ s as the WDT overflow period. Preparation for entering erase mode (erase setup) is performed next by setting the ESU bit in FLMCR1. The operating mode is then switched to erase mode by setting the E bit in FLMCR1 after the elapse of at least (t_{sesu}) μ s. The time during which the E bit is set is the flash memory erase time. Ensure that the erase time does not exceed (t_{se}) ms.

Note: With flash memory erasing, preprogramming (setting all memory data in the memory to be erased to all 0) is not necessary before starting the erase procedure.

21C.9.4 Erase-Verify Mode

In erase-verify mode, data is read after memory has been erased to check whether it has been correctly erased.

After the elapse of the fixed erase time, clear the E bit in FLMCR1, then wait for at least (t_{ce}) μ s before clearing the ESU bit to exit erase mode. After exiting erase mode, the watchdog timer setting is also cleared. The operating mode is then switched to erase-verify mode by setting the EV bit in FLMCR1. Before reading in erase-verify mode, a dummy write of HFF data should be made to the addresses to be read. The dummy write should be executed after the elapse of (t_{sev}) μ s or more. When the flash memory is read in this state (verify data is read in 16-bit units), the data at the latched address is read. Wait at least (t_{sevr}) μ s after the dummy write before performing this read operation. If the read data has been erased (all 1), a dummy write is performed to the next address, and erase-verify is performed. If the read data is unerased, set erase mode again, and repeat the erase/erase-verify sequence as before. The maximum number of repetitions of the erase/erase-verify sequence is indicated by the maximum erase count (N). When verification is completed, exit erase-verify mode, and wait for at least (t_{cev}) μ s. If erasure has been completed on all the erase blocks, clear the SWE bit in FLMCR1, and leave a wait time of at least (t_{cswe}) μ s.

If erasing multiple blocks, set a single bit in EBR1/EBR2 for the next block to be erased, and repeat the erase/erase-verify sequence as before.

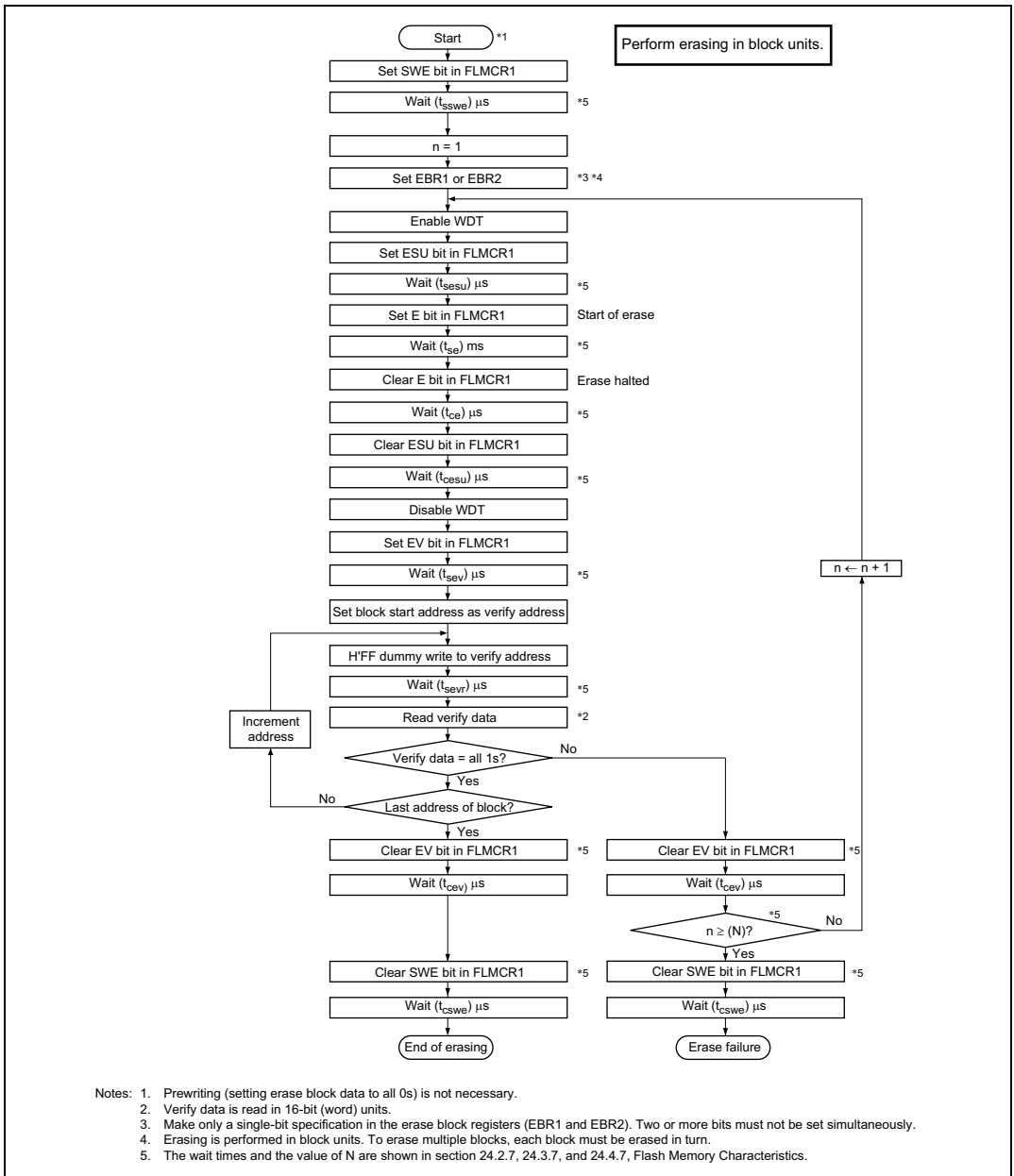

Figure 21C-13 Erase/Eraser-Verify Flowchart

21C.10 Protection

There are three kinds of flash memory program/erase protection: hardware protection, software protection, and error protection.

21C.10.1 Hardware Protection

Hardware protection refers to a state in which programming/erasing of flash memory is forcibly disabled or aborted. Hardware protection is reset by settings in flash memory control register 1 (FLMCR1), flash memory control register 2 (FLMCR2), erase block register 1 (EBR1), and erase block register 2 (EBR2). The FLMCR1, FLMCR2, EBR1, and EBR2 settings are retained in the error-protected state (See table 21C-11).

Table 21C-11 Hardware Protection

Item	Description	Functions	
		Program	Erase
FWE pin protection	<ul style="list-style-type: none"> When a low level is input to the FWE pin, FLMCR1, FLMCR2, (except bit FLER) EBR1, and EBR2 are initialized, and the program/erase-protected state is entered. 	Yes	Yes
Reset/standby protection	<ul style="list-style-type: none"> In a reset (including a WDT reset) and in standby mode, FLMCR1, FLMCR2, EBR1, and EBR2 are initialized, and the program/erase-protected state is entered. In a reset via the $\overline{\text{RES}}$ pin, the reset state is not entered unless the $\overline{\text{RES}}$ pin is held low until oscillation stabilizes after powering on. In the case of a reset during operation, hold the $\overline{\text{RES}}$ pin low for the $\overline{\text{RES}}$ pulse width specified in the AC Characteristics section. 	Yes	Yes

21C.10.2 Software Protection

Software protection can be implemented by setting the SWE bit in FLMCR1, erase block register 1 (EBR1), erase block register 2 (EBR2), and the RAMS bit in the RAM emulation register (RAMER). When software protection is in effect, setting the P or E bit in flash memory control register 1 (FLMCR1), does not cause a transition to program mode or erase mode (See table 21C-12).

Table 21C-12 Software Protection

Item	Description	Functions	
		Program	Erase
SWE bit protection	<ul style="list-style-type: none"> Setting bit SWE in FLMCR1 to 0 will place area on-chip flash memory in the program/erase-protected state (Execute the program in the on-chip RAM, external memory). 	Yes	Yes
Block specification protection	<ul style="list-style-type: none"> Erase protection can be set for individual blocks by settings in erase block register 1 (EBR1) and erase block register 2 (EBR2). Setting EBR1 and EBR2 to H'00 places all blocks in the erase-protected state. 	—	Yes
Emulation protection	<ul style="list-style-type: none"> Setting the RAMS bit to 1 in the RAM emulation register (RAMER) places all blocks in the program/erase-protected state. 	Yes	Yes

21C.10.3 Error Protection

In error protection, an error is detected when chip runaway occurs during flash memory programming/erasing, or operation is not performed in accordance with the program/erase algorithm, and the program/erase operation is aborted. Aborting the program/erase operation prevents damage to the flash memory due to overprogramming or overerasing.

If the chip malfunctions during flash memory programming/erasing, the FLER bit is set to 1 in FLMCR2 and the error protection state is entered. The FLMCR1, FLMCR2, EBR1, and EBR2 settings are retained, but program mode or erase mode is aborted at the point at which the error occurred. Program mode or erase mode cannot be re-entered by re-setting the P or E bit. However, PV and EV bit setting is enabled, and a transition can be made to verify mode.

FLER bit setting conditions are as follows:

1. When the flash memory of the relevant address area is read during programming/erasing (including vector read and instruction fetch)
2. Immediately after exception handling (excluding a reset) during programming/erasing
3. When a SLEEP instruction (including software standby) is executed during programming/erasing

Error protection is released only by a reset and in hardware standby mode.

Figure 21C-14 shows the flash memory state transition diagram.

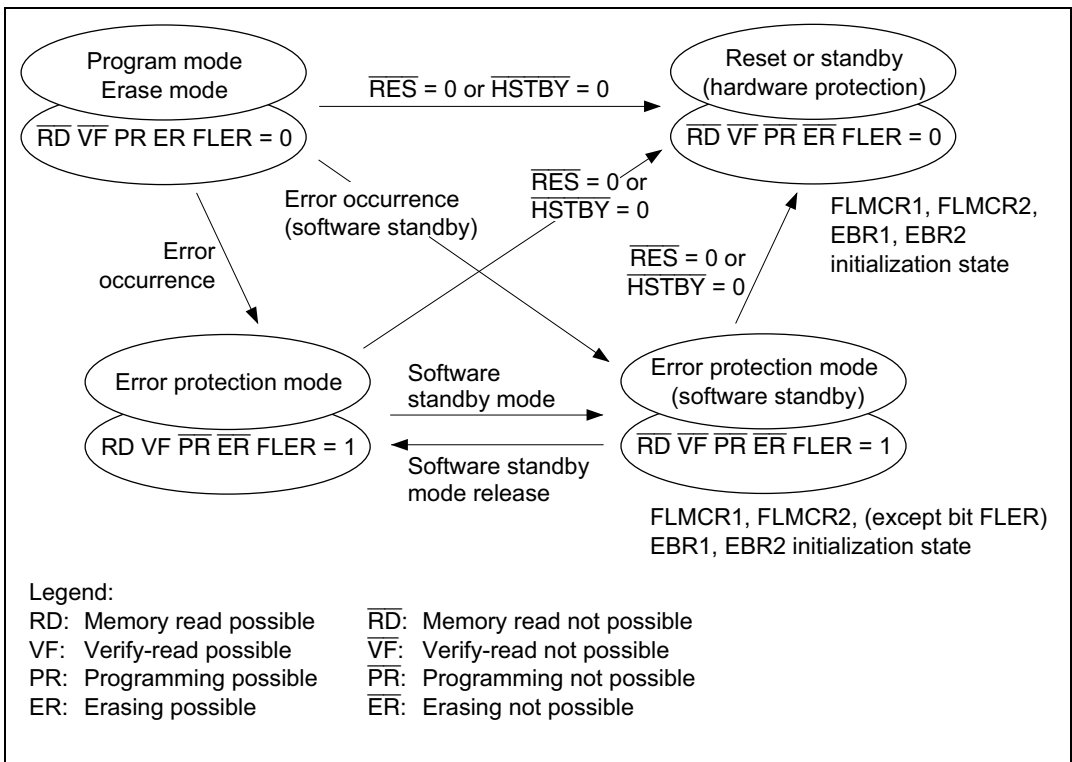

Figure 21C-14 Flash Memory State Transitions

21C.11 Flash Memory Emulation in RAM

Making a setting in the RAM emulation register (RAMER) enables part of RAM to be overlapped onto the flash memory area so that data to be written to flash memory can be emulated in RAM in real time. After the RAMER setting has been made, accesses cannot be made from the flash memory area or the RAM area overlapping flash memory. Emulation can be performed in user mode and user program mode. Figure 21C-15 shows an example of emulation of real-time flash memory programming.

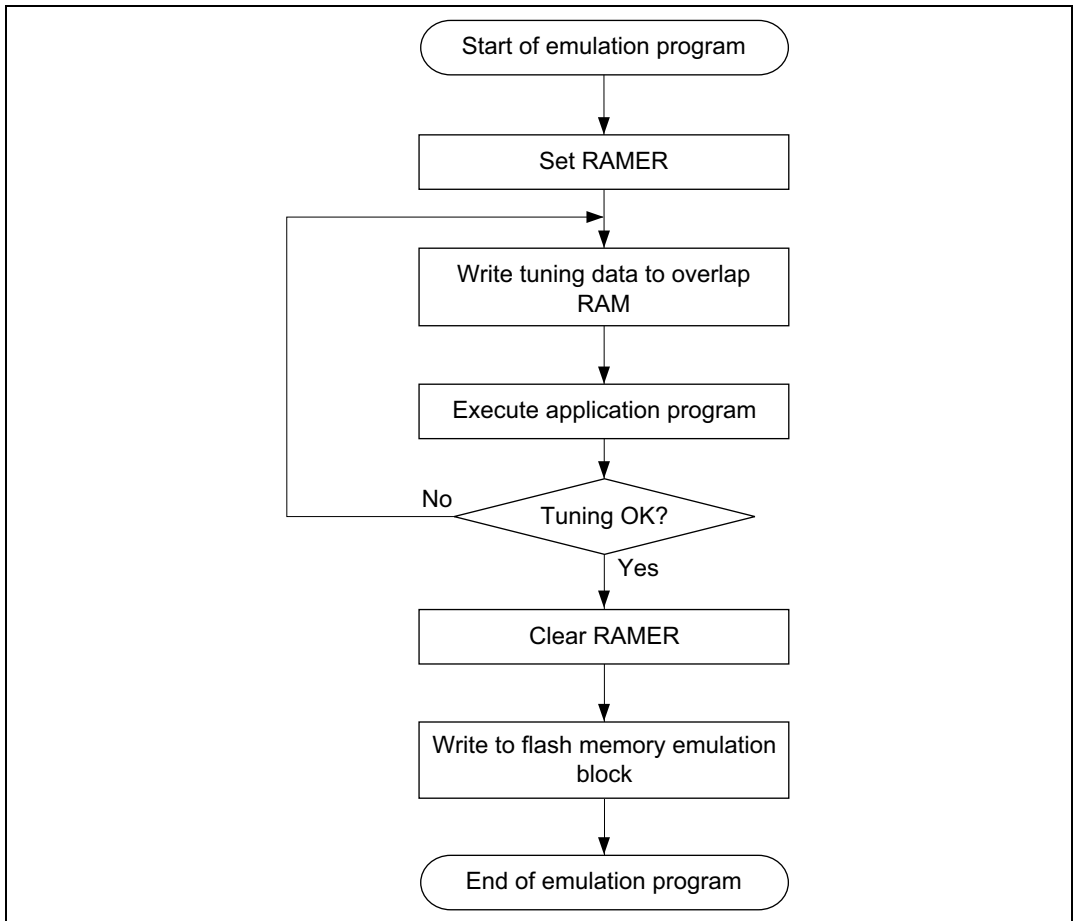

Figure 21C-15 Flowchart for Flash Memory Emulation in RAM

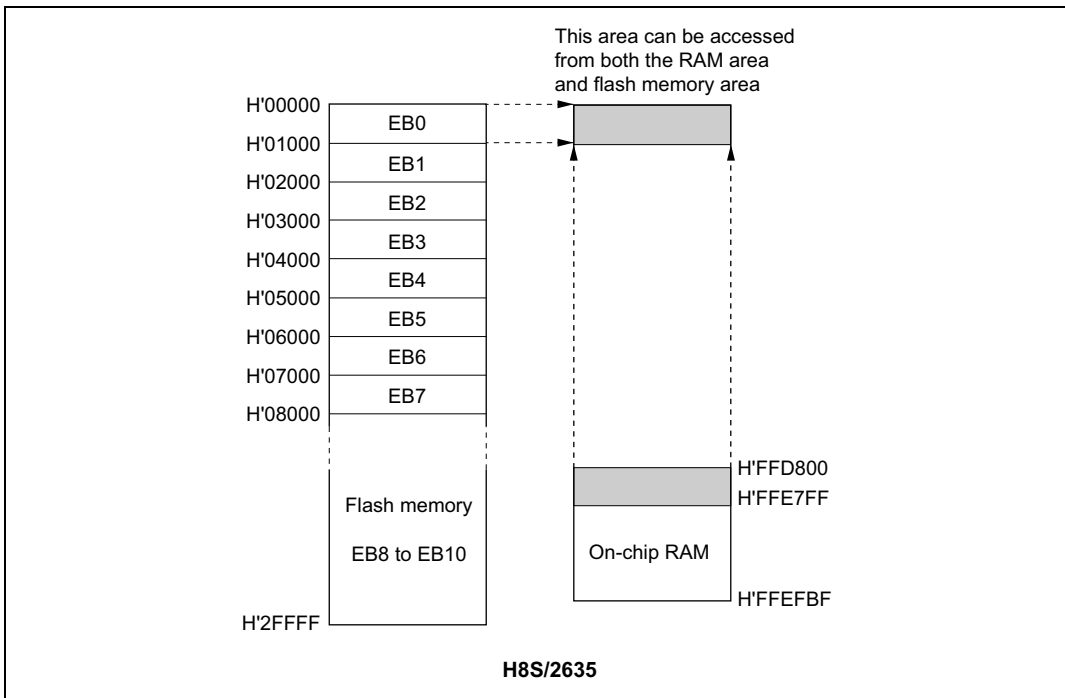

Figure 21C-16 Example of RAM Overlap Operation

Example in which Flash Memory Block Area EB0 is Overlapped

1. Set bits RAMS, RAM2 to RAM0 in RAMER to 1, 0, 0, 0, to overlap part of RAM onto the area (EB0) for which real-time programming is required.
2. Real-time programming is performed using the overlapping RAM.
3. After the program data has been confirmed, the RAMS bit is cleared, releasing RAM overlap.
4. The data written in the overlapping RAM is written into the flash memory space (EB0).

- Notes:
1. When the RAMS bit is set to 1, program/erase protection is enabled for all blocks regardless of the value of RAM2 to RAM0 (emulation protection). In this state, setting the P or E bit in flash memory control register 1 (FLMCR1), will not cause a transition to program mode or erase mode. When actually programming or erasing a flash memory area, the RAMS bit should be cleared to 0.
 2. A RAM area cannot be erased by execution of software in accordance with the erase algorithm while flash memory emulation in RAM is being used.
 3. Block area EB0 contains the vector table. When performing RAM emulation, the vector table is needed in the overlap RAM.

21C.12 Interrupt Handling when Programming/Erasing Flash Memory

All interrupts, including NMI interrupt is disabled when flash memory is being programmed or erased (when the P or E bit is set in FLMCR1), and while the boot program is executing in boot mode*¹, to give priority to the program or erase operation. There are three reasons for this:

1. Interrupt during programming or erasing might cause a violation of the programming or erasing algorithm, with the result that normal operation could not be assured.
2. In the interrupt exception handling sequence during programming or erasing, the vector would not be read correctly*², possibly resulting in MCU runaway.
3. If interrupt occurred during boot program execution, it would not be possible to execute the normal boot mode sequence.

For these reasons, in on-board programming mode alone there are conditions for disabling interrupt, as an exception to the general rule. However, this provision does not guarantee normal erasing and programming or MCU operation. All requests, including NMI interrupt, must therefore be restricted inside and outside the MCU when programming or erasing flash memory. NMI interrupt is also disabled in the error-protection state while the P or E bit remains set in FLMCR1.

- Notes:
1. Interrupt requests must be disabled inside and outside the MCU until the programming control program has completed programming.
 2. The vector may not be read correctly in this case for the following two reasons:
 - If flash memory is read while being programmed or erased (while the P or E bit is set in FLMCR1), correct read data will not be obtained (undetermined values will be returned).
 - If the interrupt entry in the vector table has not been programmed yet, interrupt exception handling will not be executed correctly.

21C.13 Flash Memory Programmer Mode

Programs and data can be written and erased in programmer mode as well as in the on-board programming modes. In programmer mode, flash memory read mode, auto-program mode, auto-erase mode, and status read mode are supported. In auto-program mode, auto-erase mode, and status read mode, a status polling procedure is used, and in status read mode, detailed internal signals are output after execution of an auto-program or auto-erase operation.

In programmer mode, set the mode pins to programmer mode (see table 21C-13) and input a 12 MHz input clock.

Table 21C-13 shows the pin settings for programmer mode.

Table 21C-13 Programmer Mode Pin Settings

Pin Names	Settings
Mode pins: MD2, MD1, MD0	Low level input to MD2, MD1, and MD0.
Mode setting pins: PF0, P16, P14	High level input to PF0, low level input to P16 and P14
FWE pin	High level input (in auto-program and auto-erase modes)
$\overline{\text{RES}}$ pin	Reset circuit
XTAL, EXTAL, PLLCAP, PLLVSS pins	Oscillator circuit
VCL	Internal voltage step-down circuit

21C.13.1 Socket Adapter and Memory Map

In programmer mode in which the PROM writer is used, reading from memory (verification), writing, and initializing the flash memory (erasing all of its contents) are enabled. At this time, a dedicated conversion socket adapter must be attached to a general-purpose PROM writer. Table 21C-14 shows the types of the socket adapters. For programmer mode on this LSI, one of the socket adapters listed in table 21C-14 should be used.

Table 21C-14 Type of Socket Adapter

Product Name	Package Type	Socket Adapter Type	Manufacturer
HD64F2635F	128 pin QFP (FP-128B)	ME2636ESHF1H	Minato Electronics Inc.
		HF2636Q128D4001	Data I/O Japan Corporation

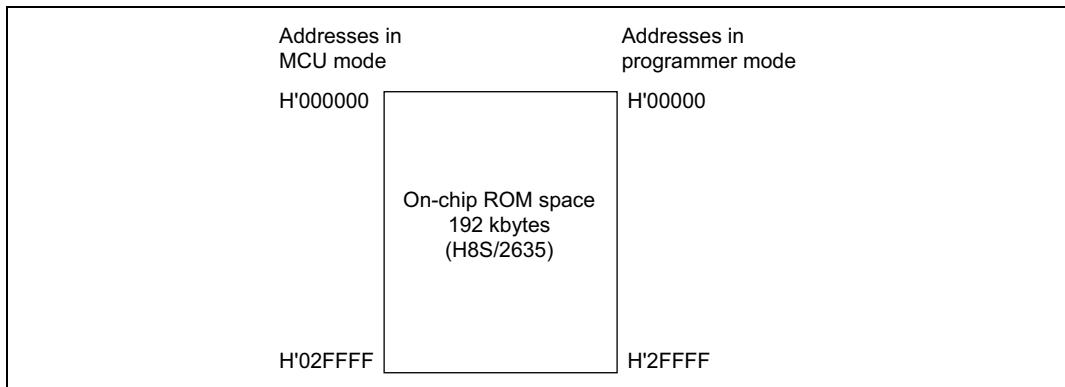

Figure 21C-17 On-Chip ROM Memory Map

21C.13.2 Programmer Mode Operation

Table 21C-15 shows how the different operating modes are set when using programmer mode, and table 21C-16 lists the commands used in programmer mode. Details of each mode are given below.

- **Memory Read Mode**
Memory read mode supports byte reads.
- **Auto-Program Mode**
Auto-program mode supports programming of 128 bytes at a time. Status polling is used to confirm the end of auto-programming.
- **Auto-Erase Mode**
Auto-erase mode supports automatic erasing of the entire flash memory. Status polling is used to confirm the end of auto-programming.
- **Status Read Mode**
Status polling is used for auto-programming and auto-erasing, and normal termination can be confirmed by reading the I/O6 signal. In status read mode, error information is output if an error occurs.

Table 21C-15 Settings for Various Operating Modes in Programmer Mode

Mode	Pin Names					
	FWE	\overline{CE}	\overline{OE}	\overline{WE}	I/O7 to I/O0	A18 to A0
Read	H or L	L	L	H	Data output	Ain ^{*2}
Output disable	H or L	L	H	H	Hi-Z	X
Command write	H or L ^{*3}	L	H	L	Data input	Ain ^{*2}
Chip disable ^{*1}	H or L	H	X	X	Hi-Z	X

- Notes: 1. Chip disable is not a standby state; internally, it is an operation state.
 2. Ain indicates that there is also address input in auto-program mode.
 3. For command writes in auto-program and auto-erase modes, input a high level to the FWE pin.

Table 21C-16 Programmer Mode Commands

Command Name	Number of Cycles	1st Cycle			2nd Cycle		
		Mode	Address	Data	Mode	Address	Data
Memory read mode	1 + n	Write	X	H'00	Read	RA	Dout
Auto-program mode	129	Write	X	H'40	Write	WA	Din
Auto-erase mode	2	Write	X	H'20	Write	X	H'20
Status read mode	2	Write	X	H'71	Write	X	H'71

- Notes: 1. In auto-program mode, 129 cycles are required for command writing by a simultaneous 128-byte write.
 2. In memory read mode, the number of cycles depends on the number of address write cycles (n).

21C.13.3 Memory Read Mode

- After completion of auto-program/auto-erase/status read operations, a transition is made to the command wait state. When reading memory contents, a transition to memory read mode must first be made with a command write, after which the memory contents are read.
- In memory read mode, command writes can be performed in the same way as in the command wait state.
- Once memory read mode has been entered, consecutive reads can be performed.
- After powering on, memory read mode is entered.

Table 21C-17 AC Characteristics in Transition to Memory Read ModeConditions: $V_{CC} = 5.0 \text{ V} \pm 0.5 \text{ V}$, $V_{SS} = 0 \text{ V}$, $T_a = 25^\circ\text{C} \pm 5^\circ\text{C}$

Item	Symbol	Min.	Max.	Unit
Command write cycle	t_{nxtc}	20	—	μs
$\overline{\text{CE}}$ hold time	t_{ceh}	0	—	ns
$\overline{\text{CE}}$ setup time	t_{ces}	0	—	ns
Data hold time	t_{dh}	50	—	ns
Data setup time	t_{ds}	50	—	ns
Write pulse width	t_{wep}	70	—	ns
$\overline{\text{WE}}$ rise time	t_r	—	30	ns
$\overline{\text{WE}}$ fall time	t_f	—	30	ns

**Figure 21C-18 Timing Waveforms for Memory Read after Memory Write**

Table 21C-18 AC Characteristics in Transition from Memory Read Mode to Another ModeConditions: $V_{CC} = 5.0 \text{ V} \pm 0.5 \text{ V}$, $V_{SS} = 0 \text{ V}$, $T_a = 25^\circ\text{C} \pm 5^\circ\text{C}$

Item	Symbol	Min.	Max.	Unit
Command write cycle	t_{nxtc}	20	—	μs
$\overline{\text{CE}}$ hold time	t_{ceh}	0	—	ns
$\overline{\text{CE}}$ setup time	t_{ces}	0	—	ns
Data hold time	t_{dh}	50	—	ns
Data setup time	t_{ds}	50	—	ns
Write pulse width	t_{wep}	70	—	ns
$\overline{\text{WE}}$ rise time	t_r	—	30	ns
$\overline{\text{WE}}$ fall time	t_f	—	30	ns

**Figure 21C-19 Timing Waveforms in Transition from Memory Read Mode to Another Mode**

Table 21C-19 AC Characteristics in Memory Read ModeConditions: $V_{CC} = 5.0 \text{ V} \pm 0.5 \text{ V}$, $V_{SS} = 0 \text{ V}$, $T_a = 25^\circ\text{C} \pm 5^\circ\text{C}$

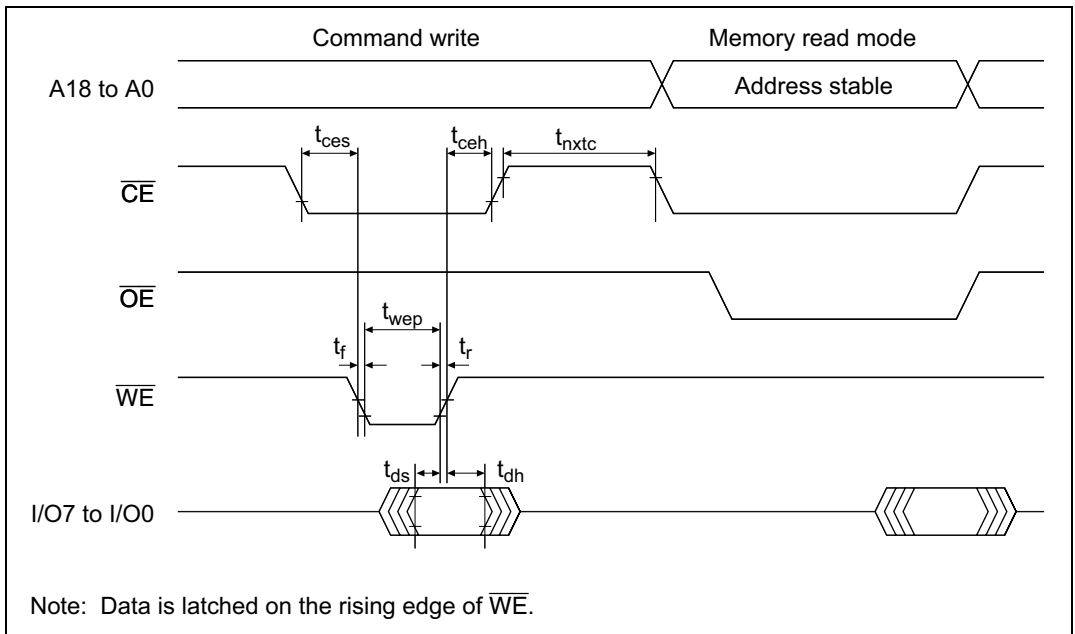
Item	Symbol	Min.	Max.	Unit
Access time	t_{acc}	—	20	μs
$\overline{\text{CE}}$ output delay time	t_{ce}	—	150	ns
$\overline{\text{OE}}$ output delay time	t_{oe}	—	150	ns
Output disable delay time	t_{df}	—	100	ns
Data output hold time	t_{oh}	5	—	ns

**Figure 21C-20 $\overline{\text{CE}}$ and $\overline{\text{OE}}$ Enable State Read Timing Waveforms****Figure 21C-21 $\overline{\text{CE}}$ and $\overline{\text{OE}}$ Clock System Read Timing Waveforms**

21C.13.4 Auto-Program Mode

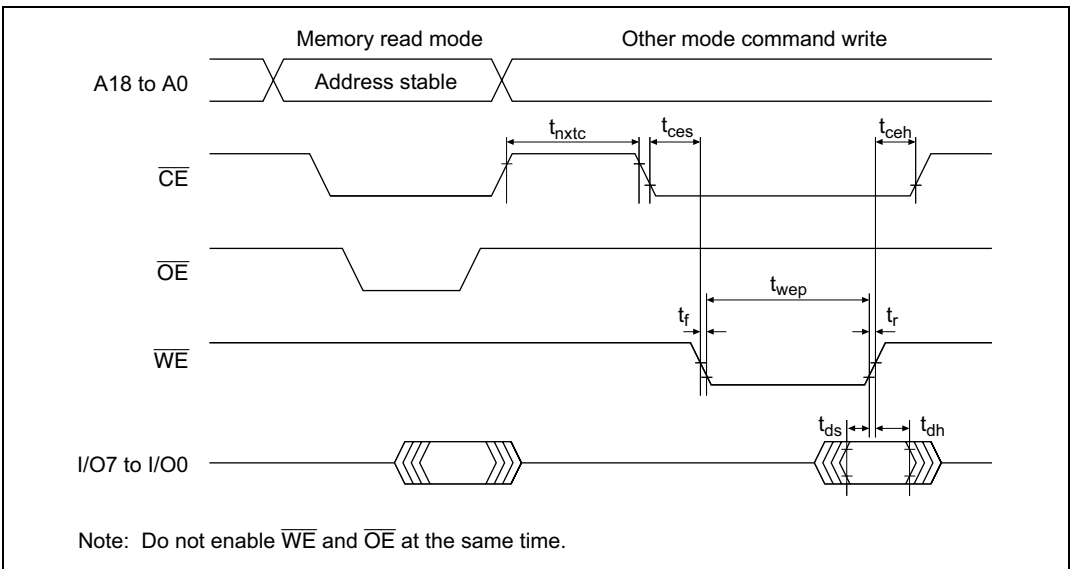
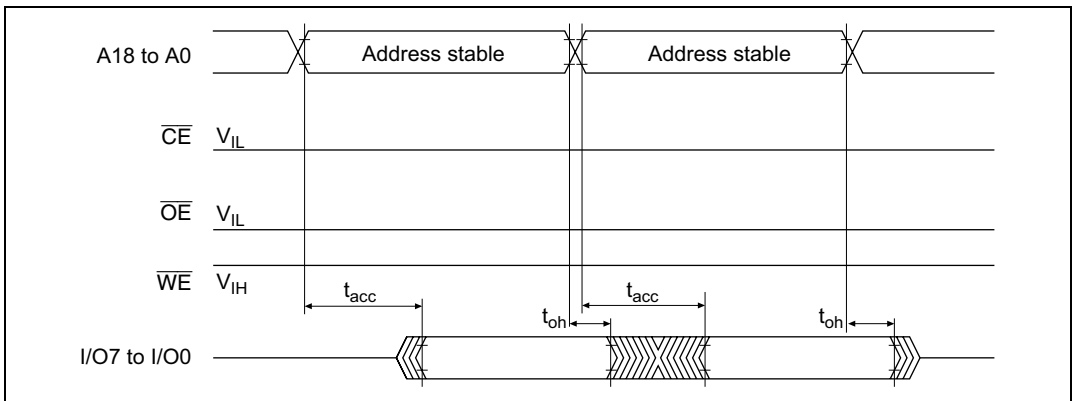
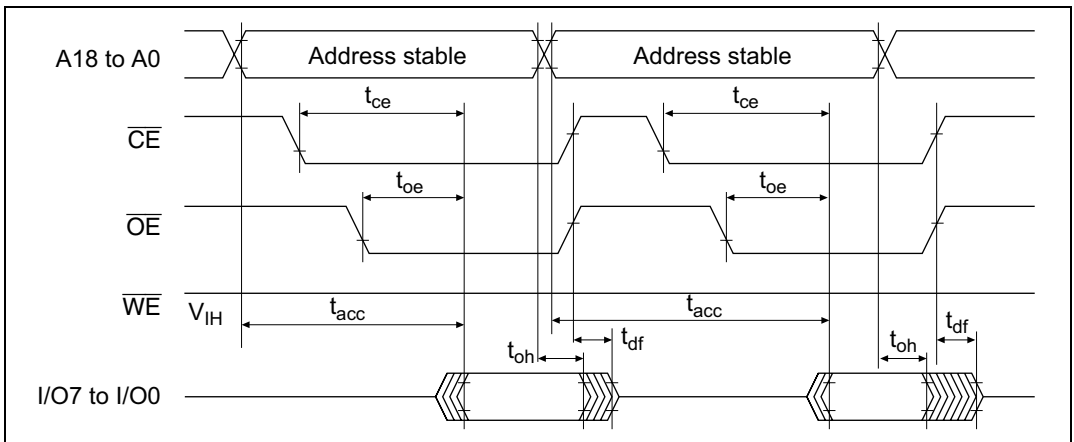
1. In auto-program mode, 128 bytes are programmed simultaneously. This should be carried out by executing 128 consecutive byte transfers.
2. A 128-byte data transfer is necessary even when programming fewer than 128 bytes. In this case, H'FF data must be written to the extra addresses.
3. The lower 7 bits of the transfer address must be low. If a value other than an effective address is input, processing will switch to a memory write operation but a write error will be flagged.
4. Memory address transfer is performed in the second cycle (figure 21C-22). Do not perform transfer after the third cycle.
5. Do not perform a command write during a programming operation.
6. Perform one auto-program operation for a 128-byte block for each address. Two or more additional programming operations cannot be performed on a previously programmed address block.
7. Confirm normal end of auto-programming by checking I/O6. Alternatively, status read mode can also be used for this purpose (I/O7 status polling uses the auto-program operation end decision pin).
8. Status polling I/O6 and I/O7 pin information is retained until the next command write. As long as the next command write has not been performed, reading is possible by enabling \overline{CE} and \overline{OE} .

Table 21C-20 AC Characteristics in Auto-Program ModeConditions: $V_{CC} = 5.0\text{ V} \pm 0.5\text{ V}$, $V_{SS} = 0\text{ V}$, $T_a = 25^\circ\text{C} \pm 5^\circ\text{C}$

Item	Symbol	Min.	Max.	Unit
Command write cycle	t_{nxtc}	20	—	μs
$\overline{\text{CE}}$ hold time	t_{ceh}	0	—	ns
$\overline{\text{CE}}$ setup time	t_{ces}	0	—	ns
Data hold time	t_{dh}	50	—	ns
Data setup time	t_{ds}	50	—	ns
Write pulse width	t_{wep}	70	—	ns
Status polling start time	t_{wsts}	1	—	ms
Status polling access time	t_{spa}	—	150	ns
Address setup time	t_{as}	0	—	ns
Address hold time	t_{ah}	60	—	ns
Memory write time	t_{write}	1	3000	ms
Write setup time	t_{pns}	100	—	ns
Write end setup time	t_{pnh}	100	—	ns
$\overline{\text{WE}}$ rise time	t_r	—	30	ns
$\overline{\text{WE}}$ fall time	t_f	—	30	ns

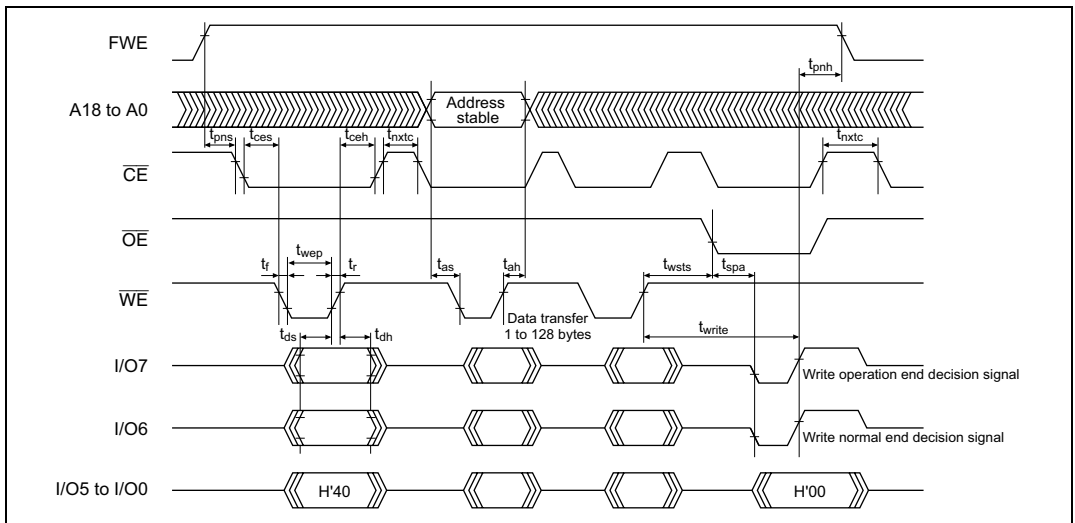
**Figure 21C-22 Auto-Program Mode Timing Waveforms**

21C.13.5 Auto-Erase Mode

1. Auto-erase mode supports only entire memory erasing.
2. Do not perform a command write during auto-erasing.
3. Confirm normal end of auto-erasing by checking I/O6. Alternatively, status read mode can also be used for this purpose (I/O7 status polling uses the auto-erase operation end decision pin).
4. Status polling I/O6 and I/O7 pin information is retained until the next command write. As long as the next command write has not been performed, reading is possible by enabling $\overline{\text{CE}}$ and $\overline{\text{OE}}$.

Table 21C-21 AC Characteristics in Auto-Erase Mode

Conditions: $V_{\text{CC}} = 5.0 \text{ V} \pm 0.5 \text{ V}$, $V_{\text{SS}} = 0 \text{ V}$, $T_{\text{a}} = 25^{\circ}\text{C} \pm 5^{\circ}\text{C}$

Item	Symbol	Min.	Max.	Unit
Command write cycle	t_{nxtc}	20	—	μs
$\overline{\text{CE}}$ hold time	t_{ceh}	0	—	ns
$\overline{\text{CE}}$ setup time	t_{ces}	0	—	ns
Data hold time	t_{dh}	50	—	ns
Data setup time	t_{ds}	50	—	ns
Write pulse width	t_{wep}	70	—	ns
Status polling start time	t_{ests}	1	—	ms
Status polling access time	$t_{\text{s pa}}$	—	150	ns
Memory erase time	t_{erase}	100	40000	ms
Erase setup time	t_{ens}	100	—	ns
Erase end setup time	t_{enh}	100	—	ns
$\overline{\text{WE}}$ rise time	t_{r}	—	30	ns
$\overline{\text{WE}}$ fall time	t_{f}	—	30	ns

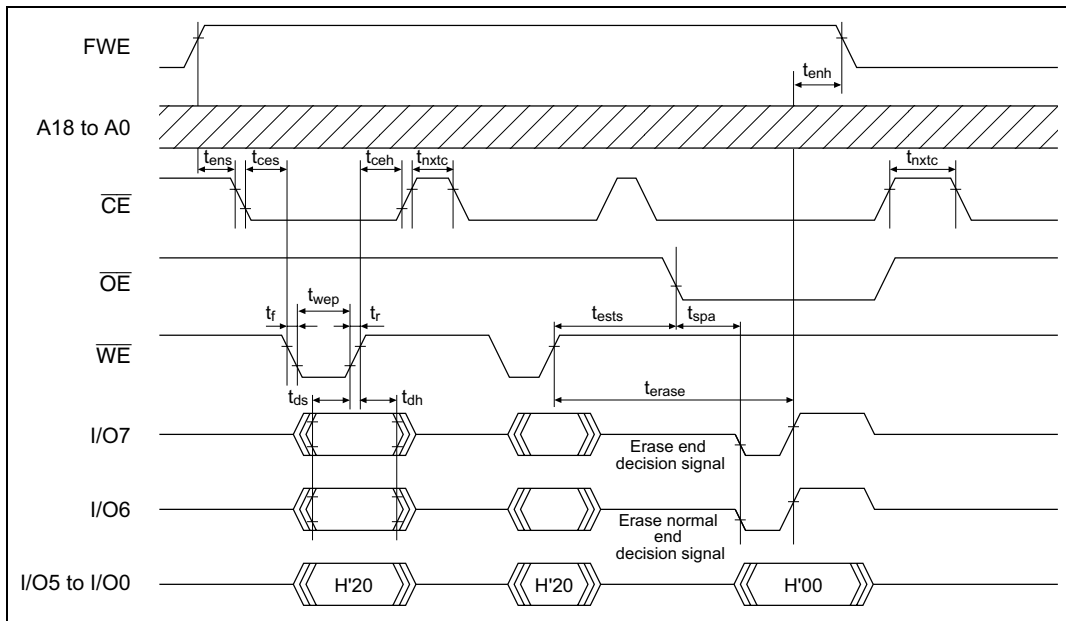

Figure 21C-23 Auto-Erase Mode Timing Waveforms

21C.13.6 Status Read Mode

1. Status read mode is provided to identify the kind of abnormal end. Use this mode when an abnormal end occurs in auto-program mode or auto-erase mode.
2. The return code is retained until a command write other than a status read mode command write is executed.

Table 21C-22 AC Characteristics in Status Read Mode

Conditions: $V_{CC} = 5.0 \text{ V} \pm 0.5 \text{ V}$, $V_{SS} = 0 \text{ V}$, $T_a = 25^\circ\text{C} \pm 5^\circ\text{C}$

Item	Symbol	Min.	Max.	Unit
Read time after command write	t_{nxtc}	20	—	μs
$\overline{\text{CE}}$ hold time	t_{ceh}	0	—	ns
$\overline{\text{CE}}$ setup time	t_{ces}	0	—	ns
Data hold time	t_{dh}	50	—	ns
Data setup time	t_{ds}	50	—	ns
Write pulse width	t_{wep}	70	—	ns
$\overline{\text{OE}}$ output delay time	t_{oe}	—	150	ns
Disable delay time	t_{df}	—	100	ns
$\overline{\text{CE}}$ output delay time	t_{ce}	—	150	ns
$\overline{\text{WE}}$ rise time	t_r	—	30	ns
$\overline{\text{WE}}$ fall time	t_f	—	30	ns

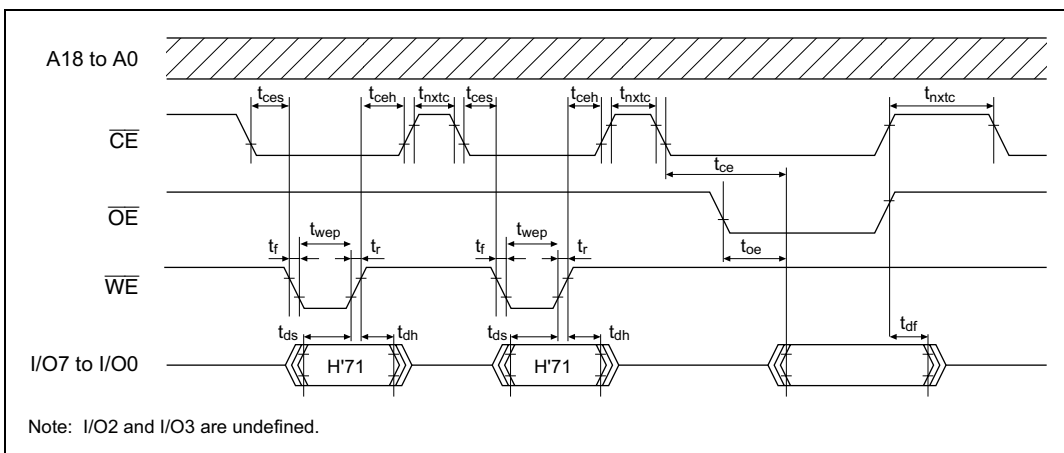

Figure 21C-24 Status Read Mode Timing Waveforms

Table 21C-23 Status Read Mode Return Commands

Pin Name	I/O7	I/O6	I/O5	I/O4	I/O3	I/O2	I/O1	I/O0
Attribute	Normal end decision	Command error	Programming error	Erase error	—	—	Programming or erase count exceeded	Effective address error
Initial value	0	0	0	0	0	0	0	0
Indications	Normal end: 0 Abnormal end: 1	Command error: 1 Otherwise: 0	Programming error: 1 Otherwise: 0	Erasing error: 1 Otherwise: 0	—	—	Count exceeded: 1 Otherwise: 0	Effective address error: 1 Otherwise: 0

Note: I/O2 and I/O3 are undefined.

21C.13.7 Status Polling

1. The I/O7 status polling flag indicates the operating status in auto-program/auto-erase mode.
2. The I/O6 status polling flag indicates a normal or abnormal end in auto-program/auto-erase mode.

Table 21C-24 Status Polling Output Truth Table

Pin Name	During Internal Operation	Abnormal End	—	Normal End
I/O7	0	1	0	1
I/O6	0	0	1	1
I/O0 to I/O5	0	0	0	0

21C.13.8 Programmer Mode Transition Time

Commands cannot be accepted during the oscillation stabilization period or the programmer mode setup period. After the programmer mode setup time, a transition is made to memory read mode.

Table 21C-25 Stipulated Transition Times to Command Wait State

Item	Symbol	Min.	Max.	Unit
Standby release (oscillation stabilization time)	t_{osc1}	30	—	ms
Programmer mode setup time	t_{bmV}	10	—	ms
V_{CC} hold time	t_{dwn}	0	—	ms

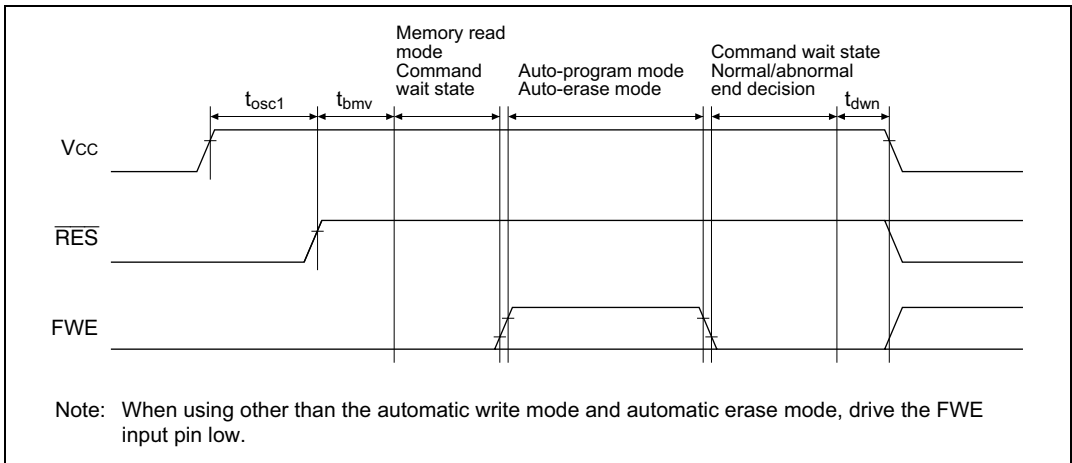

Figure 21C-25 Oscillation Stabilization Time, Boot Program Transfer Time, and Power-Down Sequence

21C.13.9 Notes on Memory Programming

1. When programming addresses which have previously been programmed, carry out auto-erasing before auto-programming.
2. When performing programming using programmer mode on a chip that has been programmed/erased in an on-board programming mode, auto-erasing is recommended before carrying out auto-programming.

- Notes:
1. The flash memory is initially in the erased state when the device is shipped by Renesas Technology. For other chips for which the erasure history is unknown, it is recommended that auto-erasing be executed to check and supplement the initialization (erase) level.
 2. Auto-programming should be performed once only on the same address block. Additional programming cannot be performed on previously programmed address blocks.

21C.14 Flash Memory and Power-Down States

In addition to its normal operating state, the flash memory has power-down states in which power consumption is reduced by halting part or all of the internal power supply circuitry.

There are three flash memory operating states:

- (1) Normal operating mode: The flash memory can be read and written to.
- (2) Power-down mode: Part of the power supply circuitry is halted, and the flash memory can be read when the LSI is operating on the subclock.
- (3) Standby mode: All flash memory circuits are halted, and the flash memory cannot be read or written to.

States (2) and (3) are flash memory power-down states. Table 21C-26 shows the correspondence between the operating states of the LSI and the flash memory.

Table 21C-26 Flash Memory Operating States

LSI Operating State	Flash Memory Operating State
High-speed mode	Normal mode (read/write)
Medium-speed mode	
Sleep mode	
Subactive mode	When PDWND = 0: Power-down mode (read-only)
Subsleep mode	When PDWND = 1: Normal mode (read-only)
Watch mode	Standby mode
Software standby mode	
Hardware standby mode	

21C.14.1 Notes on Power-Down States

1. When the flash memory is in a power-down state, part or all of the internal power supply circuitry is halted. Therefore, a power supply circuit stabilization period must be provided when returning to normal operation. When the flash memory returns to its normal operating state from a power-down state, bits STS2 to STS0 in SBYCR must be set to provide a wait time of at least 20 μ s (power supply stabilization time), even if an oscillation stabilization period is not necessary.
2. In a power-down state, FLMCR1, FLMCR2, EBR1, EBR2, RAMER, and FLPWCR cannot be read from or written to.

21C.15 Flash Memory Programming and Erasing Precautions

Precautions concerning the use of on-board programming mode, the RAM emulation function, and programmer mode are summarized below.

Use the specified voltages and timing for programming and erasing: Applied voltages in excess of the rating can permanently damage the device. Use a PROM programmer that supports the Renesas microcomputer device type* with 256-kbyte on-chip flash memory.

Only use the specified socket adapter. Failure to observe these points may result in damage to the device.

Note: * The H8S/2635 is Renesas Technology microcomputer devices with 256 kbytes of on-chip flash memory. (The H8S/2635 has 192 kbytes of PROM. The area from H'30000 to H'3FFFF should be programmed as H'FF.)

Powering on and off (see figures 21C-26 to 21C-28): Do not apply a high level to the FWE pin until V_{CC} has stabilized. Also, drive the FWE pin low before turning off V_{CC} .

When applying or disconnecting V_{CC} power, fix the FWE pin low and place the flash memory in the hardware protection state.

The power-on and power-off timing requirements should also be satisfied in the event of a power failure and subsequent recovery.

FWE application/disconnection (see figures 21C-26 to 21C-28): FWE application should be carried out when MCU operation is in a stable condition. If MCU operation is not stable, fix the FWE pin low and set the protection state.

The following points must be observed concerning FWE application and disconnection to prevent unintentional programming or erasing of flash memory:

- Apply FWE when the V_{CC} voltage has stabilized within its rated voltage range.
Apply FWE when oscillation has stabilized (after the elapse of the oscillation stabilization time).
- In boot mode, apply and disconnect FWE during a reset.
- In user program mode, FWE can be switched between high and low level regardless of the reset state. FWE input can also be switched during execution of a program in flash memory.
- Do not apply FWE if program runaway has occurred.
- Disconnect FWE only when the SWE, ESU, PSU, EV, PV, P, and E bits in FLMCR1 are cleared.
Make sure that the SWE, ESU, PSU, EV, PV, P, and E bits are not set by mistake when applying or disconnecting FWE.

Do not apply a constant high level to the FWE pin: Apply a high level to the FWE pin only when programming or erasing flash memory. A system configuration in which a high level is constantly applied to the FWE pin should be avoided. Also, while a high level is applied to the FWE pin, the watchdog timer should be activated to prevent overprogramming or overerasing due to program runaway, etc.

Use the recommended algorithm when programming and erasing flash memory: The recommended algorithm enables programming and erasing to be carried out without subjecting the device to voltage stress or sacrificing program data reliability. When setting the P or E bit in FLMCR1, the watchdog timer should be set beforehand as a precaution against program runaway, etc.

Do not set or clear the SWE bit during execution of a program in flash memory: Wait for at least 100 μ s after clearing the SWE bit before executing a program or reading data in flash memory. When the SWE bit is set, data in flash memory can be rewritten, but when $SWE = 1$, flash memory can only be read in program-verify or erase-verify mode. Access flash memory only for verify operations (verification during programming/erasing). Also, do not clear the SWE bit during programming, erasing, or verifying.

Similarly, when using the RAM emulation function while a high level is being input to the FWE pin, the SWE bit must be cleared before executing a program or reading data in flash memory.

However, the RAM area overlapping flash memory space can be read and written to regardless of whether the SWE bit is set or cleared.

Do not use interrupts while flash memory is being programmed or erased: All interrupt requests, including NMI, should be disabled during FWE application to give priority to program/erase operations.

Do not perform additional programming. Erase the memory before reprogramming: In on-board programming, perform only one programming operation on a 128-byte programming unit block. In programmer mode, too, perform only one programming operation on a 128-byte programming unit block. Programming should be carried out with the entire programming unit block erased.

Before programming, check that the chip is correctly mounted in the PROM programmer: Overcurrent damage to the device can result if the index marks on the PROM programmer socket, socket adapter, and chip are not correctly aligned.

Do not touch the socket adapter or chip during programming: Touching either of these can cause contact faults and write errors.

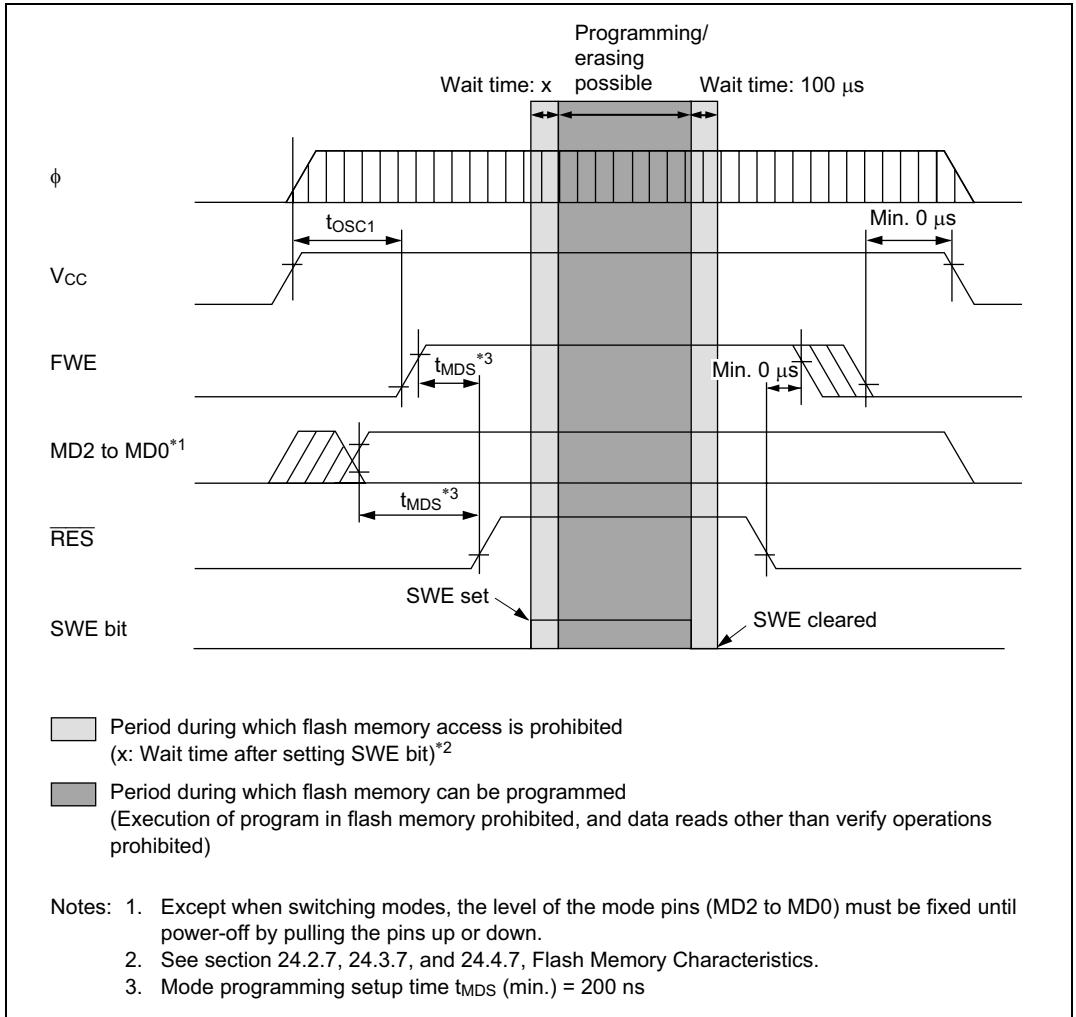

Figure 21C-26 Power-On/Off Timing (Boot Mode)

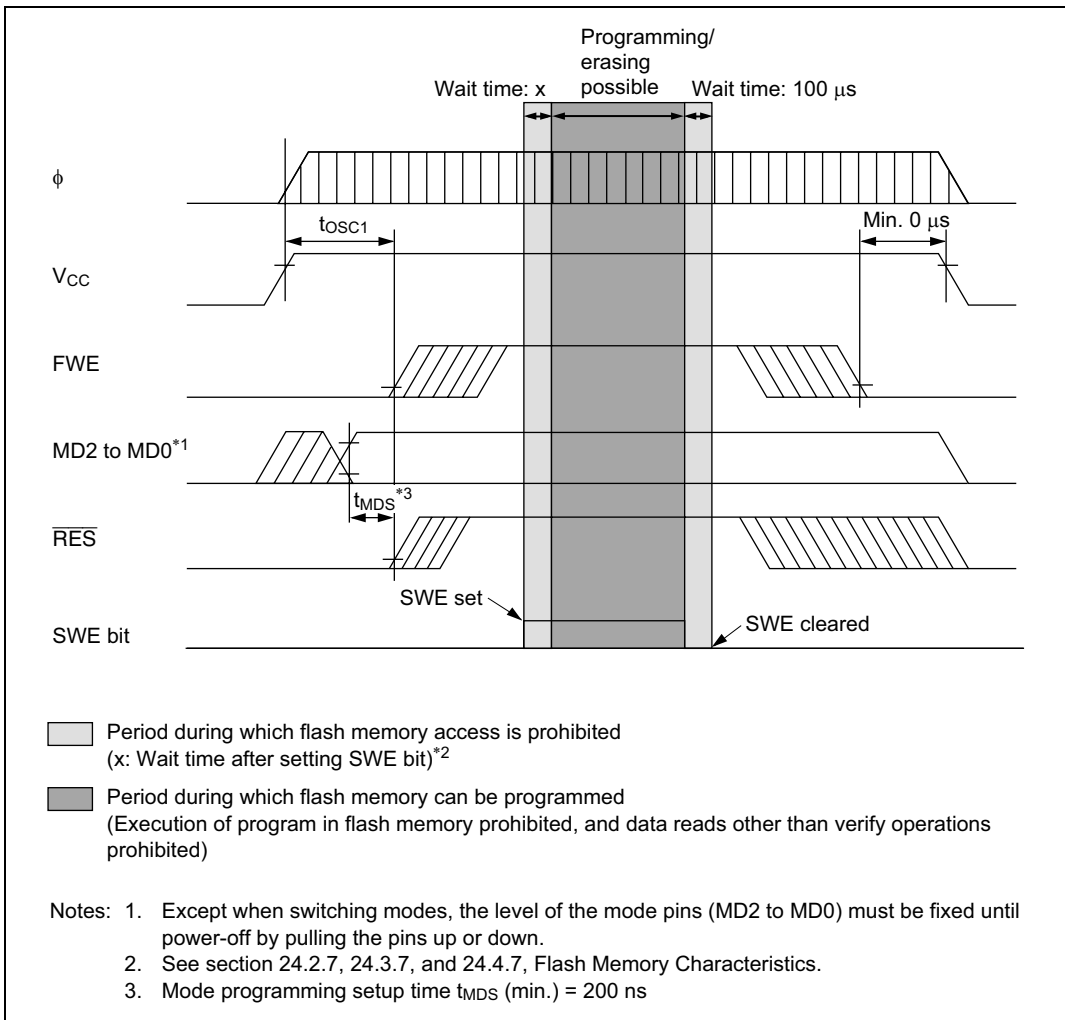

Figure 21C-27 Power-On/Off Timing (User Program Mode)

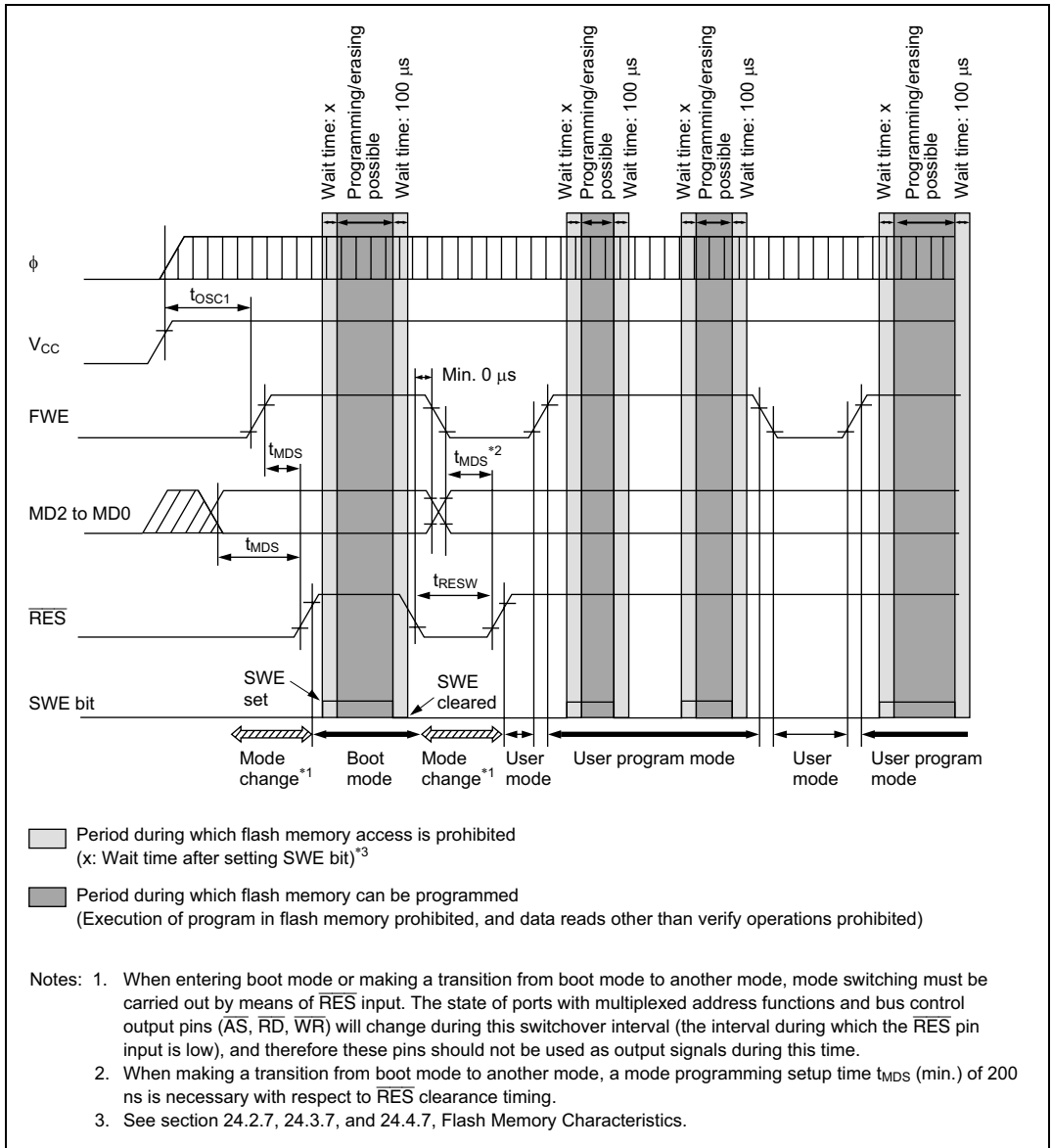

Figure 21C-28 Mode Transition Timing
(Example: Boot Mode → User Mode ↔ User Program Mode)

21C.16 Note on Switching from F-ZTAT Version to Mask ROM Version

The mask ROM version does not have the internal registers for flash memory control that are provided in the F-ZTAT version. Table 21C-24 lists the registers that are present in the F-ZTAT version but not in the mask ROM version. If a register listed in table 21C-24 is read in the mask ROM version, an undefined value will be returned. Therefore, if application software developed on the F-ZTAT version is switched to a mask ROM version product, it must be modified to ensure that the registers in table 21C-27 have no effect.

Table 21C-27 Registers Present in F-ZTAT Version but Absent in Mask ROM Version

Register	Abbreviation	Address
Flash memory control register 1	FLMCR1	H'FFA8
Flash memory control register 2	FLMCR2	H'FFA9
Erase block register 1	EBR1	H'FFAA
Erase block register 2	EBR2	H'FFAB
RAM emulation register	RAMER	H'FEDB

Section 22A Clock Pulse Generator (H8S/2636 Group, H8S/2638 Group, H8S/2630 Group)

22A.1 Overview

The chip has a built-in clock pulse generator (CPG) that generates the system clock (ϕ), the bus master clock, and internal clocks.

The clock pulse generator consists of an oscillator, PLL (phase-locked loop) circuit, clock selection circuit, medium-speed clock divider, bus master clock selection circuit, subclock oscillator, and waveform shaping circuit. The frequency can be changed by means of the PLL circuit in the CPG. Frequency changes are performed by software by means of settings in the system clock control register (SCKCR) and low-power control register (LPWRCR).

22A.1.1 Block Diagram

Figure 22A-1 shows a block diagram of the clock pulse generator.

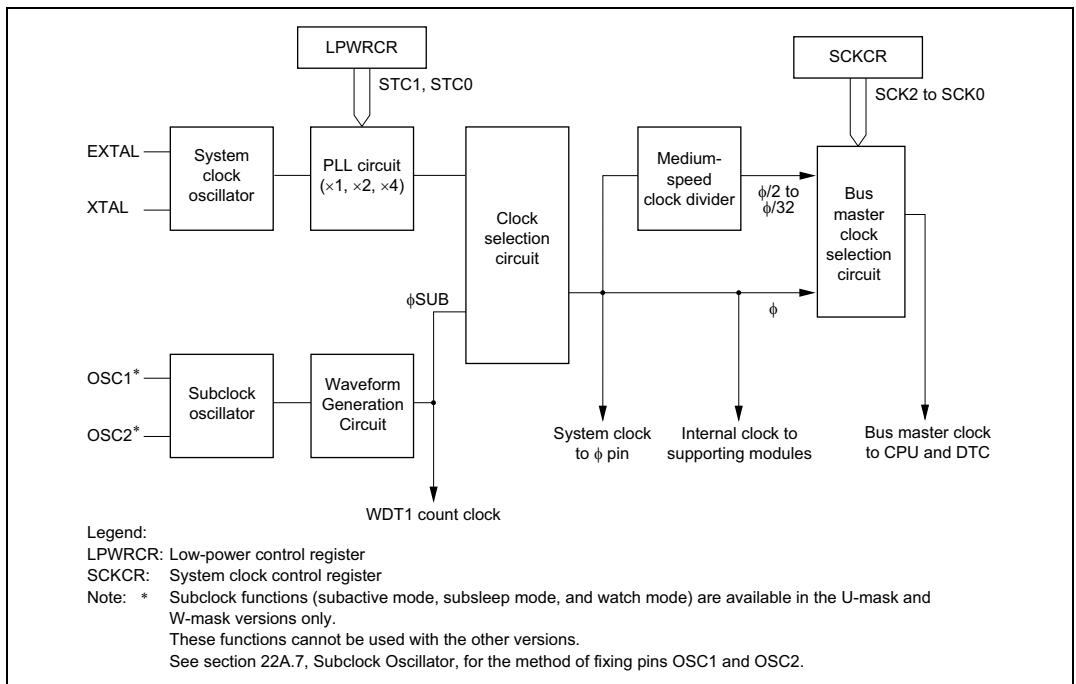

Figure 22A-1 Block Diagram of Clock Pulse Generator

22A.1.2 Register Configuration

The clock pulse generator is controlled by SCKCR and LPWRCR. Table 22A-1 shows the register configuration.

Table 22A-1 Clock Pulse Generator Register

Name	Abbreviation	R/W	Initial Value	Address*
System clock control register	SCKCR	R/W	H'00	H'FDE6
Low-power control register	LPWRCR	R/W	H'00	H'FDEC

Note:* Lower 16 bits of the address.

22A.2 Register Descriptions

22A.2.1 System Clock Control Register (SCKCR)

Bit	:	7	6	5	4	3	2	1	0
		PSTOP	—	—	—	STCS	SCK2	SCK1	SCK0
Initial value:		0	0	0	0	0	0	0	0
R/W	:	R/W	—	—	—	R/W	R/W	R/W	R/W

SCKCR is an 8-bit readable/writable register that performs ϕ clock output control and medium-speed mode control, selection of operation when the PLL circuit frequency multiplication factor is changed, and medium-speed mode control.

SCKCR is initialized to H'00 by a reset and in hardware standby mode. It is not initialized in software standby mode.

Bit 7— ϕ Clock Output Disable (PSTOP): In combination with the DDR of the applicable port, this bit controls ϕ output. See section 23A.8, 23B.12, ϕ Clock Output Disable Function for details.

Description

Bit 7	Description			
PSTOP	Normal Operating State	Sleep Mode	Software Standby Mode	Hardware Standby Mode
0	ϕ output (initial value)	ϕ output	Fixed high	High impedance
1	Fixed high	Fixed high	Fixed high	High impedance

Bits 6 to 4—Reserved: These bits are always read as 0 and cannot be modified.

Bit 3—Frequency Multiplication Factor Switching Mode Select (STCS): Selects the operation when the PLL circuit frequency multiplication factor is changed.

Bit 3

STCS	Description
0	Specified multiplication factor is valid after transition to software standby mode, watch mode*, and subactive mode* (Initial value)
1	Specified multiplication factor is valid immediately after STC bits are rewritten

Note: * Subclock functions (subactive mode, subsleep mode, and watch mode) are available in the U-mask and W-mask versions only.

These functions cannot be used with the other versions.

Bits 2 to 0—System Clock Select 2 to 0 (SCK2 to SCK0): These bits select the bus master clock.

Bit 2	Bit 1	Bit 0	Description
0	0	0	Bus master is in high-speed mode (Initial value)
		1	Medium-speed clock is $\phi/2$
	1	0	Medium-speed clock is $\phi/4$
		1	Medium-speed clock is $\phi/8$
1	0	0	Medium-speed clock is $\phi/16$
		1	Medium-speed clock is $\phi/32$
	1	—	—

22A.2.2 Low-Power Control Register (LPWRCR)

Bit	7	6	5	4	3	2	1	0
	DTON	LSON	NESEL	SUBSTP	RFCUT	—	STC1	STC0
Initial value	0	0	0	0	0	0	0	0
Read/Write	R/W	R/W	R/W	R/W	R/W	R/W	R/W	R/W

LPWRCR is an 8-bit readable/writable register that performs power-down mode control. The following pertains to bits 1 and 0. For details of the other bits, see section 23A.2.3, 23B.2.3, Low Power Control Register (LPWRCR). LPWRCR is initialized to H'00 by a reset and in hardware standby mode. It is not initialized in software standby mode.

Bits 1 and 0—Frequency Multiplication Factor (STC1, STC0): The STC bits specify the frequency multiplication factor of the PLL circuit.

Bit 1	Bit 0	
STC1	STC0	Description
0	0	×1 (Initial value)
	1	×2
1	0	×4
	1	Setting prohibited

Note: The multiplication factor should be set so that the clock frequency following multiplication does not exceed the maximum operating frequency of the LSI. It is possible to reduce power consumption and noise by using a setting of PLL ×4 for this function and lowering the external clock frequency.

22A.3 Oscillator

Clock pulses may be supplied either by connecting a crystal oscillator or inputting an external clock. In the latter case, the input clock frequency should be between 4 MHz and 20 MHz.

22A.3.1 Connecting a Crystal Resonator

Circuit Configuration: A crystal resonator can be connected as shown in the example in figure 22A-2. Select the damping resistance R_d according to table 22A-2. An AT-cut parallel-resonance crystal should be used.

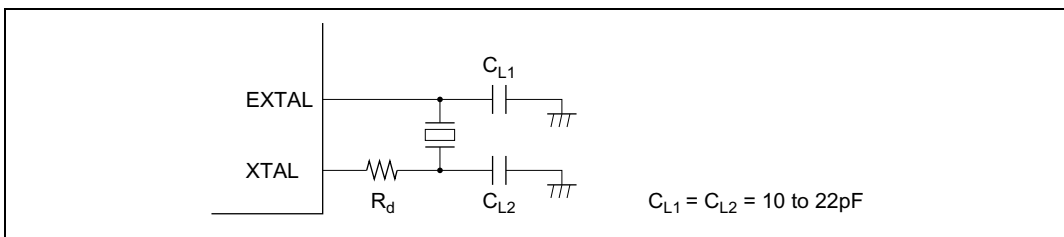

Figure 22A-2 Connection of Crystal Resonator (Example)

Table 22A-2 Damping Resistance Value

Frequency (MHz)	4	8	12	16	20
R_d (Ω)	500	200	0	0	0

Crystal Resonator: Figure 22A-3 shows the equivalent circuit of the crystal resonator. Use a crystal resonator that has the characteristics shown in table 22A-3. The crystal resonator frequency should not exceed 20 MHz.

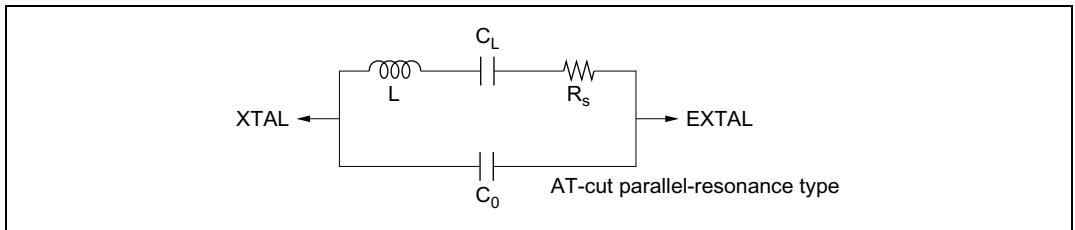

Figure 22A-3 Crystal Resonator Equivalent Circuit

Table 22A-3 Crystal Resonator Parameters

Frequency (MHz)	4	8	12	16	20
R_s max (Ω)	120	80	60	50	40
C_0 max (pF)	7	7	7	7	7

Note on Board Design: When a crystal resonator is connected, the following points should be noted:

Other signal lines should be routed away from the oscillator circuit to prevent induction from interfering with correct oscillation. See figure 22A-4.

When designing the board, place the crystal resonator and its load capacitors as close as possible to the XTAL and EXTAL pins.

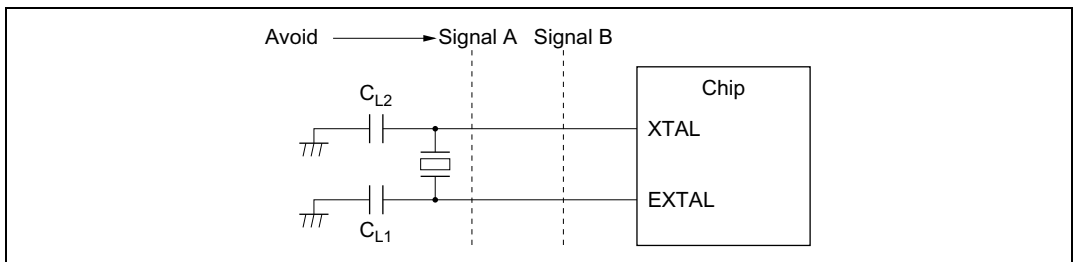

Figure 22A-4 Example of Incorrect Board Design

External circuitry such as that shown below is recommended around the PLL.

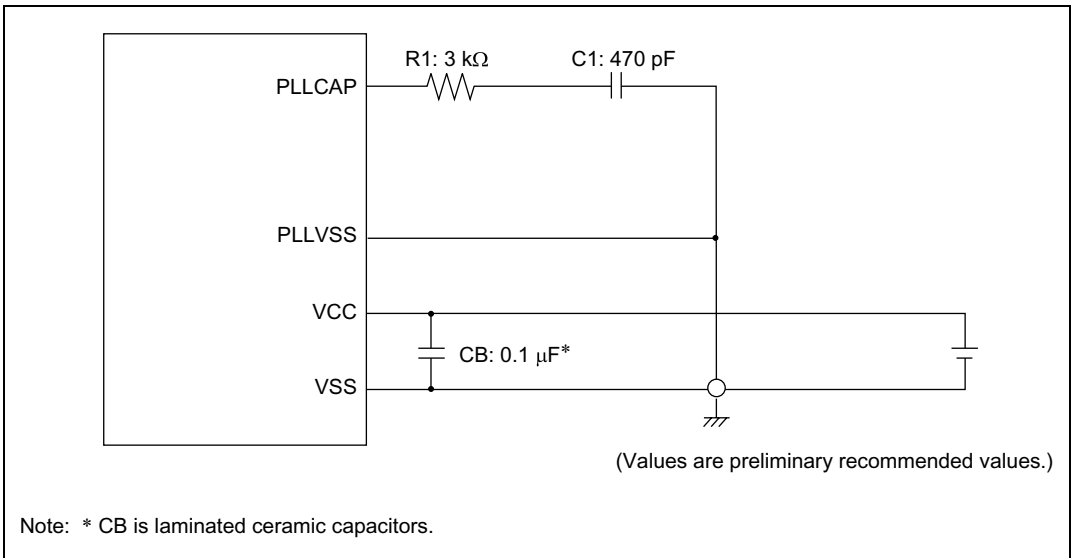

Figure 22A-5 Points for Attention when Using PLL Oscillation Circuit

Place oscillation stabilization capacitor C1 and resistor R1 close to the PLLCAP pin, and ensure that no other signal lines cross this line. Supply the C1 ground from PLLVSS.

Separate PLLVSS from the other VCC and VSS lines at the board power supply source, and be sure to insert bypass capacitors CB close to the pins.

22A.3.2 External Clock Input

Circuit Configuration

An external clock signal can be input as shown in the examples in figure 22A-6. If the XTAL pin is left open, make sure that stray capacitance is no more than 10 pF.

In example (b), make sure that the external clock is held high in standby mode.

In this case, the input clock frequency should be between 4 MHz and 20 MHz.

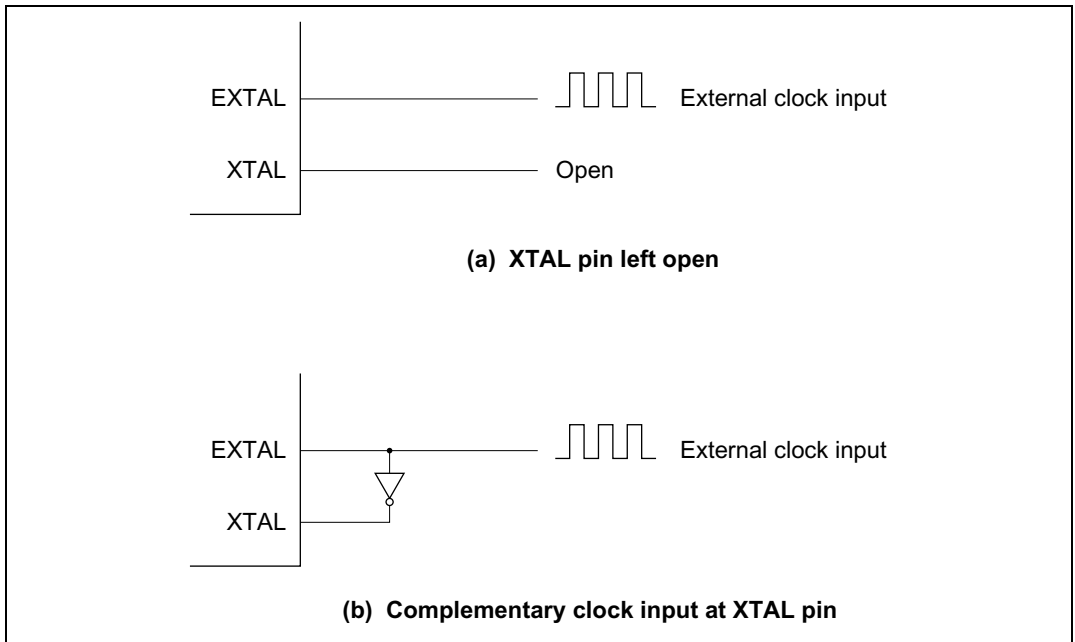

Figure 22A-6 External Clock Input (Examples)

External Clock

Table 22A-4 and figure 22A-7 show the input conditions for the external clock.

Table 22A-4 External Clock Input Conditions

Item	Symbol	$V_{CC} = 5.0 V \pm 10\%$		Unit	Test Conditions
		Min.	Max.		
External clock input low pulse width	t_{EXL}	15	—	ns	Figure 22A-7
External clock input high pulse width	t_{EXH}	15	—	ns	
External clock rise time	t_{EXr}	—	5	ns	
External clock fall time	t_{EXf}	—	5	ns	

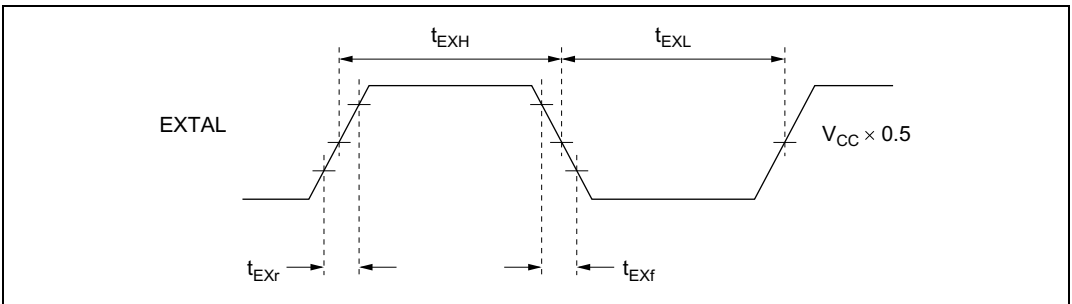

Figure 22A-7 External Clock Input Timing

22A.4 PLL Circuit

The PLL circuit has the function of multiplying the frequency of the clock from the oscillator by a factor of 1, 2, or 4. The multiplication factor is set with the STC bits in SCKCR. The phase of the rising edge of the internal clock is controlled so as to match that at the EXTAL pin.

When the multiplication factor of the PLL circuit is changed, the operation varies according to the setting of the STCS bit in SCKCR.

When $STCS = 0$ (initial value), the setting becomes valid after a transition to software standby mode, watch mode*, or subactive mode*. The transition time count is performed in accordance with the setting of bits STS2 to STS0 in SBYCR.

- [1] The initial PLL circuit multiplication factor is 1.
- [2] A value is set in bits STS2 to STS0 to give the specified transition time.
- [3] The target value is set in STC1 and STC0, and a transition is made to software standby mode, watch mode*, or subactive mode*.
- [4] The clock pulse generator stops and the value set in STC1 and STC0 becomes valid.
- [5] Software standby mode, watch mode*, or subactive mode* is cleared, and a transition time is secured in accordance with the setting in STS2 to STS0.
- [6] After the set transition time has elapsed, the LSI resumes operation using the target multiplication factor.

If a PC break is set for the SLEEP instruction that causes a transition to software standby mode in [1], software standby mode is entered and break exception handling is executed after the oscillation stabilization time. In this case, the instruction following the SLEEP instruction is executed after execution of the RTE instruction.

When $STCS = 1$, the LSI operates on the changed multiplication factor immediately after bits STC1 and STC0 are rewritten.

Note: * Subclock functions (subactive mode, subsleep mode, and watch mode) are available in the U-mask and W-mask versions only.

These functions cannot be used with the other versions.

22A.5 Medium-Speed Clock Divider

The medium-speed clock divider divides the system clock to generate $\phi/2$, $\phi/4$, $\phi/8$, $\phi/16$, and $\phi/32$.

22A.6 Bus Master Clock Selection Circuit

The bus master clock selection circuit selects the system clock (ϕ) or one of the medium-speed clocks ($\phi/2$, $\phi/4$, or $\phi/8$, $\phi/16$, and $\phi/32$) to be supplied to the bus master, according to the settings of the SCK2 to SCK0 bits in SCKCR.

22A.7 Subclock Oscillator

Connecting 32.768kHz Quartz Oscillator (U Mask, W Mask): To supply a clock to the subclock divider, connect a 32.768kHz quartz oscillator, as shown in figure 22A-8. See section 22A.3.1, “Notes on Board Design” for notes on connecting quartz oscillators.

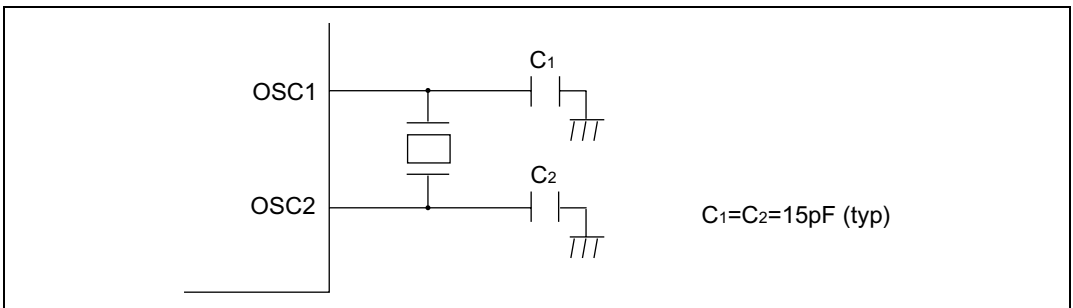

Figure 22A-8 Example Connection of 32.768kHz Quartz Oscillator

Figure 22A-9 shows the equivalence circuit for a 32.768kHz oscillator.

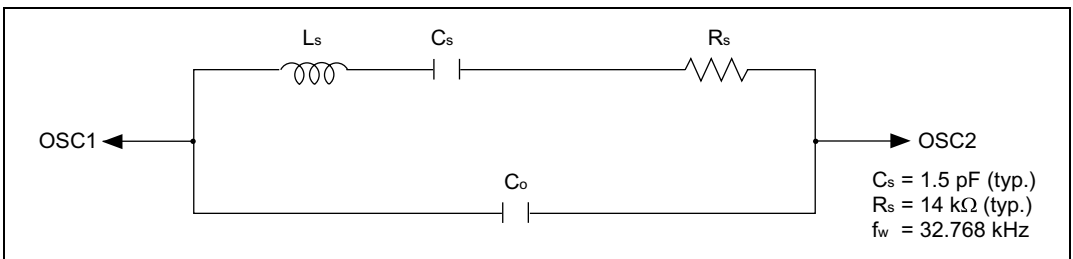

Figure 22A-9 Equivalence Circuit for 32.768kHz Oscillator

Handling Pins when Subclock not Required: If no subclock is required, connect the OSC1 pin to VSS and leave OSC2 open, as shown in figure 22A-10.

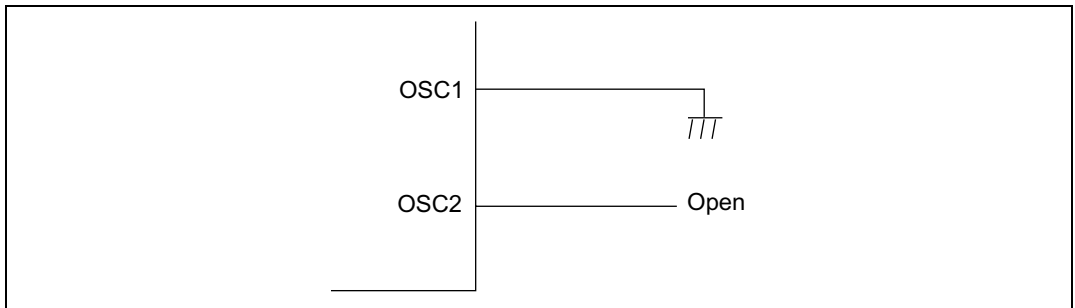

Figure 22A-10 Pin Handling when Subclock not Required

22A.8 Subclock Waveform Generation Circuit

To eliminate noise from the subclock input to OSC1, the subclock is sampled using the dividing clock ϕ . The sampling frequency is set using the NESEL bit of LPWRCR. For details, see section 23A.2.3, 23B.2.3, Low Power Control Register (LPWRCR).

No sampling is performed in subactive mode*, subsleep mode*, or watch mode*.

Note: * Subclock functions (subactive mode, subsleep mode, and watch mode) are available in the U-mask and W-mask versions only.

These functions cannot be used with the other versions.

22A.9 Note on Crystal Resonator

Since various characteristics related to the crystal resonator are closely linked to the user's board design, thorough evaluation is necessary on the user's part, for both the mask versions and F-ZTAT versions, using the resonator connection examples shown in this section as a guide. As the resonator circuit ratings will depend on the floating capacitance of the resonator and the mounting circuit, the ratings should be determined in consultation with the resonator manufacturer. The design must ensure that a voltage exceeding the maximum rating is not applied to the oscillator pin.

Section 22B Clock Pulse Generator (H8S/2639 Group, H8S/2635 Group)

22B.1 Overview

The chip has a built-in clock pulse generator (CPG) that generates the system clock (ϕ), the bus master clock, and internal clocks.

The clock pulse generator consists of an oscillator, PLL (phase-locked loop) circuit, system clock selection circuit, medium-speed clock divider, bus master clock selection circuit, and subclock divider. The frequency can be changed by means of the PLL circuit in the CPG. Frequency changes are performed by software by means of settings in the system clock control register (SCKCR) and low-power control register (LPWRCR).

22B.1.1 Block Diagram

Figure 22B-1 shows a block diagram of the clock pulse generator.

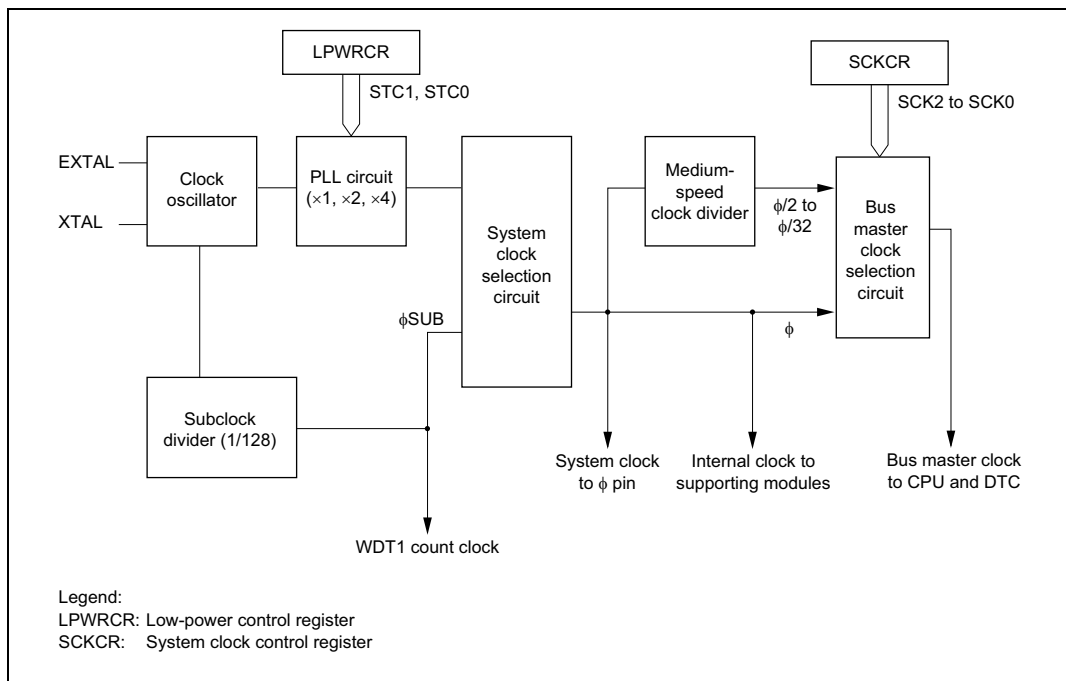

Figure 22B-1 Block Diagram of Clock Pulse Generator

22B.1.2 Register Configuration

The clock pulse generator is controlled by SCKCR and LPWRCR. Table 22B-1 shows the register configuration.

Table 22B-1 Clock Pulse Generator Register

Name	Abbreviation	R/W	Initial Value	Address*
System clock control register	SCKCR	R/W	H'00	H'FDE6
Low-power control register	LPWRCR	R/W	H'00	H'FDEC

Note:* Lower 16 bits of the address.

22B.2 Register Descriptions

22B.2.1 System Clock Control Register (SCKCR)

Bit	:	7	6	5	4	3	2	1	0
		PSTOP	—	—	—	STCS	SCK2	SCK1	SCK0
Initial value:		0	0	0	0	0	0	0	0
R/W	:	R/W	—	—	—	R/W	R/W	R/W	R/W

SCKCR is an 8-bit readable/writable register that performs ϕ clock output control and medium-speed mode control, selection of operation when the PLL circuit frequency multiplication factor is changed, and medium-speed mode control.

SCKCR is initialized to H'00 by a reset and in hardware standby mode. It is not initialized in software standby mode.

Bit 7— ϕ Clock Output Disable (PSTOP): In combination with the DDR of the applicable port, this bit controls ϕ output. See section 23B.12, ϕ Clock Output Disable Function for details.

Description

Bit 7	Description			
PSTOP	Normal Operating State	Sleep Mode	Software Standby Mode	Hardware Standby Mode
0	ϕ output (initial value)	ϕ output	Fixed high	High impedance
1	Fixed high	Fixed high	Fixed high	High impedance

Bits 6 to 4—Reserved: These bits are always read as 0 and cannot be modified.

Bit 3—Frequency Multiplication Factor Switching Mode Select (STCS): Selects the operation when the PLL circuit frequency multiplication factor is changed.

Bit 3

STCS	Description
0	Specified multiplication factor is valid after transition to software standby mode, watch mode, and subactive mode (Initial value)
1	Specified multiplication factor is valid immediately after STC bits are rewritten

Bits 2 to 0—System Clock Select 2 to 0 (SCK2 to SCK0): These bits select the bus master clock.

Bit 2	Bit 1	Bit 0	Description
SCK2	SCK1	SCK0	
0	0	0	Bus master is in high-speed mode (Initial value)
		1	Medium-speed clock is $\phi/2$
	1	0	Medium-speed clock is $\phi/4$
		1	Medium-speed clock is $\phi/8$
1	0	0	Medium-speed clock is $\phi/16$
		1	Medium-speed clock is $\phi/32$
	1	—	—

22B.2.2 Low-Power Control Register (LPWRCR)

Bit	:	7	6	5	4	3	2	1	0
		DTON	LSON	NESEL	SUBSTP	RFCUT	—	STC1	STC0
Initial value	:	0	0	0	0	0	0	0	0
R/W	:	R/W	R/W	R/W	R/W	R/W	R/W	R/W	R/W

LPWRCR is an 8-bit readable/writable register that performs power-down mode control. The following pertains to bits 1 and 0. For details of the other bits, see section 23B.2.3, Low Power Control Register (LPWRCR). LPWRCR is initialized to H'00 by a reset and in hardware standby mode. It is not initialized in software standby mode.

Bits 1 and 0—Frequency Multiplication Factor (STC1, STC0): The STC bits specify the frequency multiplication factor of the PLL circuit.

Bit 1	Bit 0	
STC1	STC0	Description
0	0	×1 (Initial value)
	1	×2
1	0	×4
	1	Setting prohibited

Note: A system clock frequency multiplied by the multiplication factor (STC1 and STC0) should not exceed the maximum operating frequency defined in section 24, Electrical Characteristics.

22B.3 Oscillator

Clock pulses may be supplied either by connecting a crystal oscillator or inputting an external clock. In the latter case, the input clock frequency should be between 4 MHz and 5 MHz.

22B.3.1 Connecting a Crystal Resonator

Circuit Configuration: A crystal resonator can be connected as shown in the example in figure 22B-2. Select the damping resistance R_d according to table 22B-2. An AT-cut parallel-resonance crystal should be used.

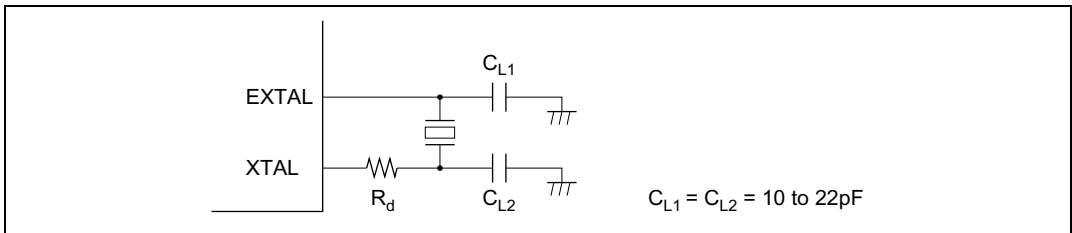

Figure 22B-2 Connection of Crystal Resonator (Example)

Table 22B-2 Damping Resistance Value

Frequency (MHz)	4	5
R_d (Ω)	500	200

Crystal Resonator: Figure 22B-3 shows the equivalent circuit of the crystal resonator. Use a crystal resonator that has the characteristics shown in table 18-3. The crystal resonator frequency should not exceed 5 MHz.

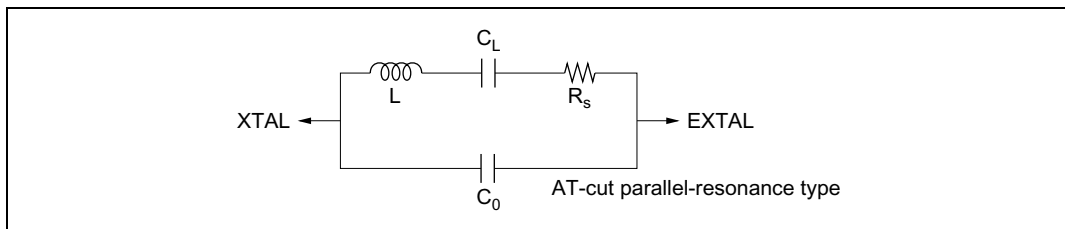

Figure 22B-3 Crystal Resonator Equivalent Circuit

Table 22B-3 Crystal Resonator Parameters

Frequency (MHz)	4	5
R_s max (Ω)	120	80
C_0 max (pF)	7	7

Note on Board Design: When a crystal resonator is connected, the following points should be noted:

Other signal lines should be routed away from the oscillator circuit to prevent induction from interfering with correct oscillation. See figure 22B-4.

When designing the board, place the crystal resonator and its load capacitors as close as possible to the XTAL and EXTAL pins.

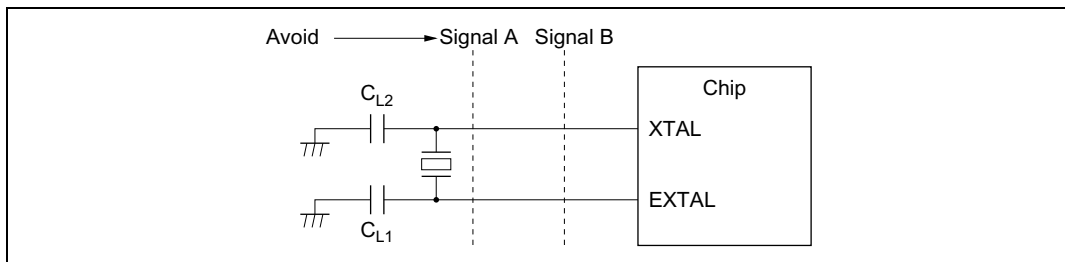

Figure 22B-4 Example of Incorrect Board Design

External circuitry such as that shown below is recommended around the PLL.

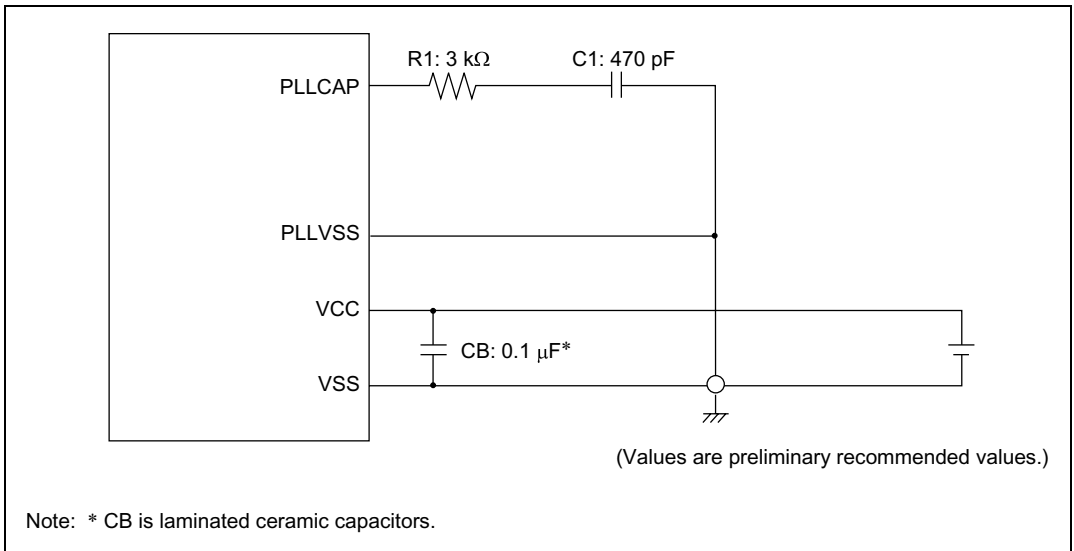

Figure 22B-5 Points for Attention when Using PLL Oscillation Circuit

Place oscillation stabilization capacitor C1 and resistor R1 close to the PLLCAP pin, and ensure that no other signal lines cross this line. Supply the C1 ground from PLLVSS.

Separate PLLVSS from the other VCC and VSS lines at the board power supply source, and be sure to insert bypass capacitors CB close to the pins.

22B.3.2 External Clock Input

Circuit Configuration

An external clock signal can be input as shown in the examples in figure 22B-6. If the XTAL pin is left open, make sure that stray capacitance is no more than 10 pF.

In example (b), make sure that the external clock is held high in standby mode.

In this case, the input clock frequency should be between 4 MHz and 5 MHz.

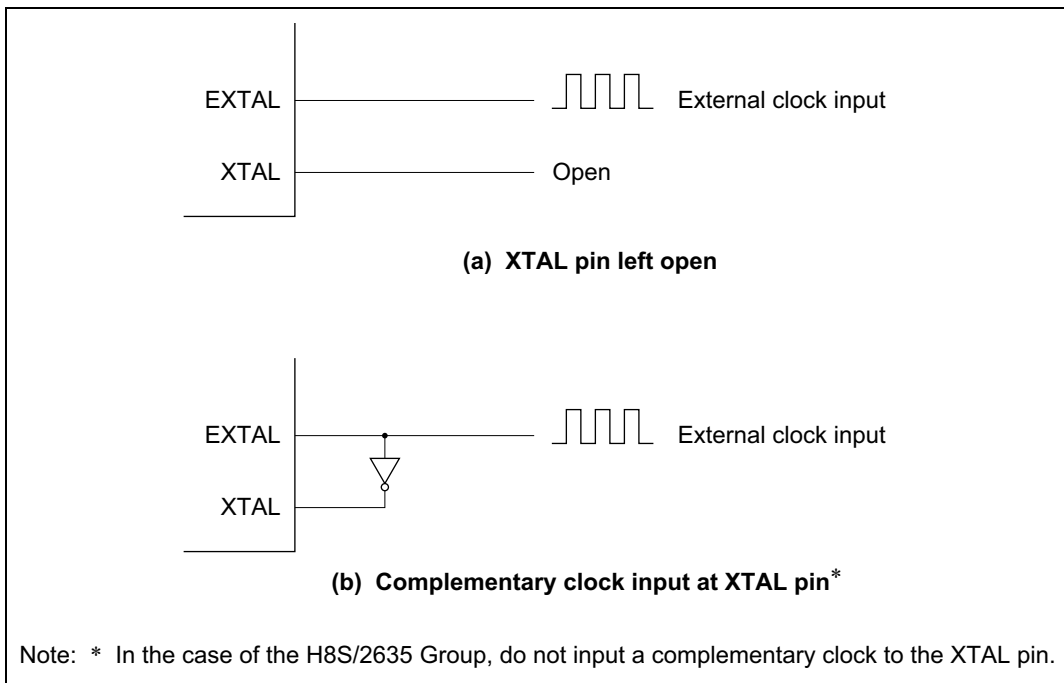

Figure 22B-6 External Clock Input (Examples)

External Clock

Table 22B-4 and figure 22B-7 show the input conditions for the external clock.

Table 22B-4 External Clock Input Conditions

Item	Symbol	$V_{CC} = 5.0 V \pm 10\%$		Unit	Test Conditions
		Min.	Max.		
External clock input low pulse width	t_{EXL}	50	—	ns	Figure 22B-7
External clock input high pulse width	t_{EXH}	50	—	ns	
External clock rise time	t_{EXr}	—	5	ns	
External clock fall time	t_{EXf}	—	5	ns	

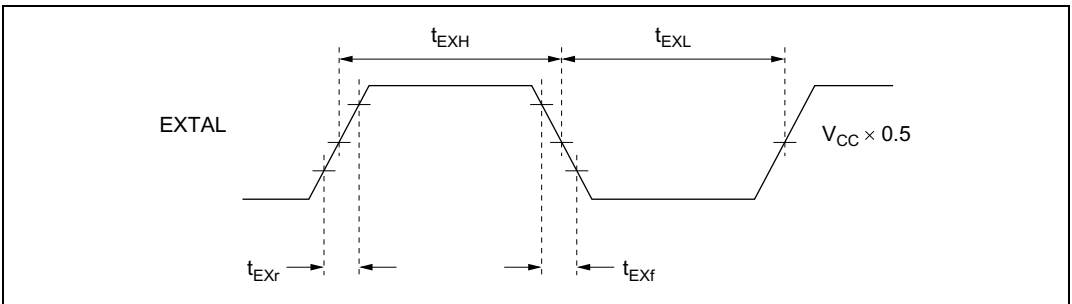

Figure 22B-7 External Clock Input Timing

22B.4 PLL Circuit

The PLL circuit has the function of multiplying the frequency of the clock from the oscillator by a factor of 1, 2, or 4. The multiplication factor is set with the STC bits in SCKCR. The phase of the rising edge of the internal clock is controlled so as to match that at the EXTAL pin.

When the multiplication factor of the PLL circuit is changed, the operation varies according to the setting of the STCS bit in SCKCR.

When STCS = 0 (initial value), the setting becomes valid after a transition to software standby mode, watch mode, or subactive mode. The transition time count is performed in accordance with the setting of bits STS2 to STS0 in SBYCR.

- [1] The initial PLL circuit multiplication factor is 1.
- [2] A value is set in bits STS2 to STS0 to give the specified transition time.
- [3] The target value is set in STC1 and STC0, and a transition is made to software standby mode, watch mode, or subactive mode.
- [4] The clock pulse generator stops and the value set in STC1 and STC0 becomes valid.
- [5] Software standby mode, watch mode, or subactive mode is cleared, and a transition time is secured in accordance with the setting in STS2 to STS0.
- [6] After the set transition time has elapsed, the LSI resumes operation using the target multiplication factor.

If a PC break is set for the SLEEP instruction that causes a transition to software standby mode in [1], software standby mode is entered and break exception handling is executed after the oscillation stabilization time. In this case, the instruction following the SLEEP instruction is executed after execution of the RTE instruction.

When STCS = 1, the LSI operates on the changed multiplication factor immediately after bits STC1 and STC0 are rewritten.

22B.5 Medium-Speed Clock Divider

The medium-speed clock divider divides the system clock to generate $\phi/2$, $\phi/4$, $\phi/8$, $\phi/16$, and $\phi/32$.

22B.6 Bus Master Clock Selection Circuit

The bus master clock selection circuit selects the system clock (ϕ) or one of the medium-speed clocks ($\phi/2$, $\phi/4$, or $\phi/8$, $\phi/16$, and $\phi/32$) to be supplied to the bus master, according to the settings of the SCK2 to SCK0 bits in SCKCR.

22B.7 Subclock Divider

The subclock divider divides the input clock into 1/128 to generate ϕ_{SUB} .

22B.8 Note on Resonator

Since various characteristics related to the resonator are closely linked to the user's board design, thorough evaluation is necessary on the user's part, for both the mask versions and F-ZTAT versions, using the resonator connection examples shown in this section as a guide. As the resonator circuit ratings will depend on the floating capacitance of the resonator and the mounting circuit, the ratings should be determined in consultation with the resonator manufacturer. The design must ensure that a voltage exceeding the maximum rating is not applied to the oscillator pin.

Section 23A Power-Down Modes

[HD64F2636F, HD64F2638F, HD6432636F, HD6432638F,
HD64F2630F, HD6432630F, HD64F2635F, HD6432635F,
HD6432634F]

Subclock functions are not available in the HD64F2636F, HD64F2638F, HD6432636F, HD6432638F, HD64F2630F, and HD6432630F.

23A.1 Overview

In addition to the normal program execution state, the chip has nine power-down modes in which operation of the CPU and oscillator is halted and power dissipation is reduced. Low-power operation can be achieved by individually controlling the CPU, on-chip supporting modules, and so on.

The chip operating modes are as follows:

- (1) High-speed mode
- (2) Medium-speed mode
- (3) Sleep mode
- (4) Module stop mode
- (5) Software standby mode
- (6) Hardware standby mode

(2) to (6) are low power dissipation states. Sleep mode is CPU states, medium-speed mode is a CPU and bus master state, and module stop mode is an internal peripheral function (including bus masters other than the CPU) state. Some of these states can be combined.

After a reset, the LSI is in high-speed mode with modules other than the DTC in module stop mode.

- Notes:
1. Subclock functions (subactive mode, subsleep mode, and watch mode) are available in the U-mask and W-mask versions only.
These functions cannot be used with the other versions.
 2. See section 22A.7, Subclock Oscillator, for the method of fixing pins OSC1 and OSC2 when not used.

Table 23A-1 shows the internal state of the LSI in the respective modes. Table 23A-2 shows the conditions for shifting between the low power dissipation modes.

Figure 23A-1 is a mode transition diagram.

Table 23A-1 LSI Internal States in Each Mode

Function		High-Speed	Medium-Speed	Sleep	Module Stop	Software Standby	Hardware Standby
System clock pulse generator		Functioning	Functioning	Functioning	Functioning	Halted	Halted
CPU	Instructions Registers	Functioning	Medium-speed operation	Halted (retained)	High/medium-speed operation	Halted (retained)	Halted (undefined)
External interrupts	NMI IRQ0 to IRQ5	Functioning	Functioning	Functioning	Functioning	Functioning	Halted
Peripheral functions	WDT1	Functioning	Functioning	Functioning	—	Halted (retained)	Halted (reset)
	WDT0	Functioning	Functioning	Functioning	—	Halted (retained)	Halted (reset)
	DTC	Functioning	Medium-speed operation	Functioning	Halted (retained)	Halted (retained)	Halted (reset)
	PBC	Functioning	Medium-speed operation	Functioning	Halted (retained)	Halted (retained)	Halted (reset)
	TPU	Functioning	Functioning	Functioning	Halted (retained)	Halted (retained)	Halted (reset)
	PPG						
	D/A0, 1						
	SCI0	Functioning	Functioning	Functioning	Halted (reset)	Halted (reset)	Halted (reset)
	SCI1						
	SCI2						
	PWM						
	A/D						
	RAM	Functioning	Functioning	Functioning (DTC)	Functioning	Retained	Retained
I/O	Functioning	Functioning	Functioning	Functioning	Retained	High impedance	
HCAN	Functioning	Functioning	Functioning	Halted (reset)	Halted (reset)	Halted (reset)	

Note: “Halted (retained)” means that internal register values are retained. The internal state is “operation suspended.”

“Halted (reset)” means that internal register values and internal states are initialized.

In module stop mode, only modules for which a stop setting has been made are halted (reset or retained).

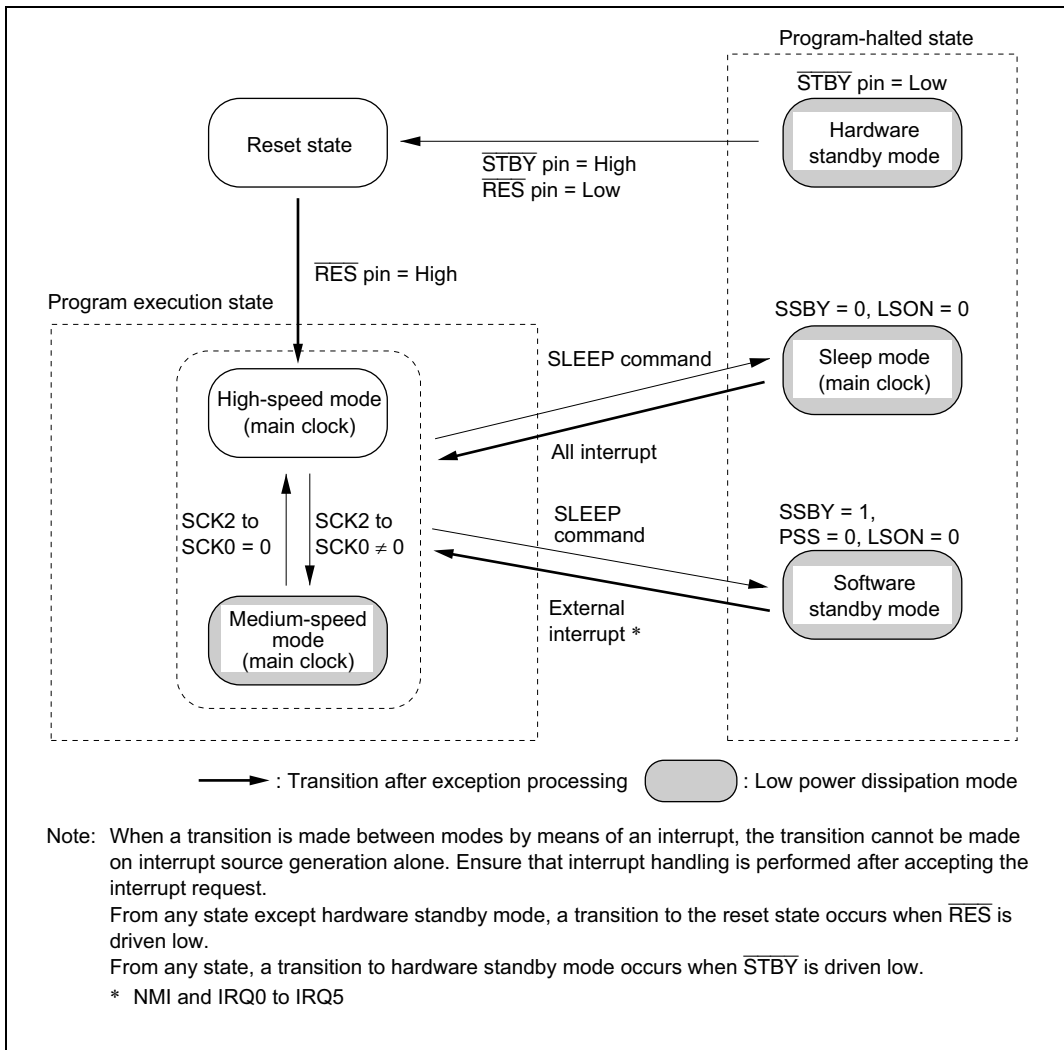

Figure 23A-1 Mode Transition Diagram

Table 23A.2 Low Power Dissipation Mode Transition Conditions

Pre-Transition State	Status of Control Bit at Transition				State after Transition Invoked by SLEEP Command	State after Transition Back from Low Power Mode Invoked by Interrupt
	SSBY	PSS	LSON	DTON		
High-speed/ Medium-speed	0	*	0	*	Sleep	High-speed/Medium-speed
	0	*	1	*	—	—
	1	0	0	*	Software standby	High-speed/Medium-speed
	1	0	1	*	—	—
	1	1	0	0	—	—
	1	1	1	0	—	—
	1	1	0	1	—	—
	1	1	1	1	—	—
Subactive	0	0	*	*	—	—
	0	1	0	*	—	—
	0	1	1	*	—	—
	1	0	*	*	—	—
	1	1	0	0	—	High-speed
	1	1	1	0	—	—
	1	1	0	1	High-speed	—
	1	1	1	1	—	—

Legend:

*: Don't care

—: Do not set

23A.1.1 Register Configuration

Power-down modes are controlled by the SBYCR, SCKCR, LPWRCR, TCSR (WDT1), and MSTPCR registers. Table 23A-3 summarizes these registers.

Table 23A-3 Power-Down Mode Registers

Name	Abbreviation	R/W	Initial Value	Address*1
Standby control register	SBYCR	R/W	H'58	H'FDE4
System clock control register	SCKCR	R/W	H'00	H'FDE6
Low-power control register	LPWRCR	R/W	H'00	H'FDEC
Timer control/status register	TCSR	R/W	H'00	H'FFA2
Module stop control register A, B, C, D	MSTPCRA	R/W	H'3F	H'FDE8
	MSTPCRB	R/W	H'FF	H'FDE9
	MSTPCRC	R/W	H'FF	H'FDEA
	MSTPCRD	R/W	B'11*****	H'FC60

Note: 1. Lower 16 bits of the address.

23A.2 Register Descriptions

23A.2.1 Standby Control Register (SBYCR)

Bit	:	7	6	5	4	3	2	1	0
		SSBY	STS2	STS1	STS0	OPE	—	—	—
Initial value	:	0	1	0	1	1	0	0	0
R/W	:	R/W	R/W	R/W	R/W	R/W	—	—	—

SBYCR is an 8-bit readable/writable register that performs power-down mode control.

SBYCR is initialized to H'58 by a reset and in hardware standby mode. It is not initialized in software standby mode.

Bit 7—Software Standby (SSBY): When making a low power dissipation mode transition by executing the SLEEP instruction, the operating mode is determined in combination with other control bits.

Note that the value of the SSBY bit does not change even when shifting between modes using interrupts.

Bit 7

SSBY	Description
0	Shifts to sleep mode when the SLEEP instruction is executed in high-speed mode or medium-speed mode. (Initial value)
1	Shifts to software standby mode when the SLEEP instruction is executed in high-speed mode or medium-speed mode.

Bits 6 to 4—Standby Timer Select 2 to 0 (STS2 to STS0): These bits select the MCU wait time for clock stabilization when shifting to high-speed mode or medium-speed mode by using a specific interrupt or command to cancel software standby mode. With a quartz oscillator (Table 23A-5), select a wait time of 8ms (oscillation stabilization time) or more, depending on the operating frequency. With an external clock, select a standby time of 2 ms or more (PLL oscillator settling time), based on the operating frequency.

Bit 6	Bit 5	Bit 4	
STS2	STS1	STS0	Description
0	0	0	Standby time = 8192 states
		1	Standby time = 16384 states
	1	0	Standby time = 32768 states
		1	Standby time = 65536 states
1	0	0	Standby time = 131072 states
		1	Standby time = 262144 states (Initial value)
	1	0	Reserved
		1	Standby time = 16 states (Setting prohibited)

Bit 3—Output Port Enable (OPE): This bit specifies whether the output of the address bus and bus control signals (\overline{AS} , \overline{RD} , \overline{HWR} , \overline{LWR}) is retained or set to high-impedance state in the software standby mode.

Bit 3

OPE	Description
0	In software standby mode, address bus and bus control signals are high-impedance.
1	In software standby mode, the output state of the address bus and bus control signals is retained. (Initial value)

Bits 2 to 0—Reserved: These bits always return 0 when read, and cannot be written to.

23A.2.2 System Clock Control Register (SCKCR)

Bit	:	7	6	5	4	3	2	1	0
		PSTOP	—	—	—	STCS	SCK2	SCK1	SCK0
Initial value	:	0	0	0	0	0	0	0	0
R/W	:	R/W	—	—	—	R/W	R/W	R/W	R/W

SCKCR is an 8-bit readable/writable register that performs ϕ clock output control and medium-speed mode control.

SCKCR is initialized to H'00 by a reset and in hardware standby mode. It is not initialized in software standby mode.

Bit 7— ϕ Clock Output Disable (PSTOP): In combination with the DDR of the applicable port, this bit controls ϕ output. See section 23A.8, ϕ Clock Output Disable Function for details.

		Description		
Bit 7		High-Speed Mode,	Software	Hardware
PSTOP		Medium-Speed Mode	Standby Mode	Standby Mode
0		ϕ output (initial value)	Fixed high	High impedance
1		Fixed high	Fixed high	High impedance

Bits 6 to 4—Reserved: These bits are always read as 0 and cannot be modified.

Bit 3—Frequency Multiplication Factor Switching Mode Select (STCS): Selects the operation when the PLL circuit frequency multiplication factor is changed.

Bit 3	Description
STCS	
0	Specified multiplication factor is valid after transition to software standby mode (Initial value)
1	Specified multiplication factor is valid immediately after STC bits are rewritten

Bits 2 to 0—System Clock Select (SCK2 to SCK0): These bits select the bus master clock in high-speed mode, and medium-speed mode.

Bit 2	Bit 1	Bit 0	Description
SCK2	SCK1	SCK0	
0	0	0	Bus master in high-speed mode (Initial value)
		1	Medium-speed clock is $\phi/2$
	1	0	Medium-speed clock is $\phi/4$
1	0	1	Medium-speed clock is $\phi/8$
		1	Medium-speed clock is $\phi/16$
	1	1	Medium-speed clock is $\phi/32$
1	1	—	—

23A.2.3 Low-Power Control Register (LPWRCR)

Bit	:	7	6	5	4	3	2	1	0
		DTON	LSON	NESEL	SUBSTP	RFCUT	—	STC1	STC0
Initial value	:	0	0	0	0	0	0	0	0
R/W	:	R/W	R/W	R/W	R/W	R/W	R/W	R/W	R/W

The LPWRCR is an 8-bit read/write register that controls the low power dissipation modes.

The LPWRCR is initialized to H'00 at a reset and when in hardware standby mode. It is not initialized in software standby mode. The following describes bits 7 to 2. For details of other bits, see section 22A.2.2, Low-Power Control Register (LPWRCR).

Bits 7 to 3—Reserved: Bits DTON, LSON, NESEL, SUBSTP and RFCUT must always be written with 0, as this version does not support subclock operation.

Bit 2—Reserved: Only write 0 to this bit.

23A.2.4 Timer Control/Status Register (TCSR)

Bit	:	7	6	5	4	3	2	1	0
		OVF	WT/I \bar{T}	TME	PSS	RST/ \bar{NMI}	CKS2	CKS1	CKS0
Initial value	:	0	0	0	0	0	0	0	0
R/W	:	R/(W)*	R/W	R/W	R/W	R/W	R/W	R/W	R/W

Note: * Only write 0 to clear the flag.

TCSR is an 8-bit read/write register that selects the clock input to WDT1 TCNT and the mode.

Here, we describe bit 4. For details of the other bits in this register, see section 12.2.2, Timer Control/Status Register (TCSR).

The TCSR is initialized to H'00 at a reset and when in hardware standby mode. It is not initialized in software standby mode.

Bit 4—Reserved: The PSS bit must always be written with 0 since no subclock functions are available in versions other than the U-mask and W-mask versions.

23A.2.5 Module Stop Control Register (MSTPCR)

MSTPCRA

Bit	:	7	6	5	4	3	2	1	0
		MSTPA7	MSTPA6	MSTPA5	MSTPA4	MSTPA3	MSTPA2	MSTPA1	MSTPA0
Initial value :		0	0	1	1	1	1	1	1
R/W	:	R/W	R/W	R/W	R/W	R/W	R/W	R/W	R/W

MSTPCRB

Bit	:	7	6	5	4	3	2	1	0
		MSTPB7	MSTPB6	MSTPB5	MSTPB4	MSTPB3	MSTPB2	MSTPB1	MSTPB0
Initial value :		1	1	1	1	1	1	1	1
R/W	:	R/W	R/W	R/W	R/W	R/W	R/W	R/W	R/W

MSTPCRC

Bit	:	7	6	5	4	3	2	1	0
		MSTPC7	MSTPC6	MSTPC5	MSTPC4	MSTPC3	MSTPC2	MSTPC1	MSTPC0
Initial value :		1	1	1	1	1	1	1	1
R/W	:	R/W	R/W	R/W	R/W	R/W	R/W	R/W	R/W

MSTPCRD

Bit	:	7	6	5	4	3	2	1	0
		MSTPD7	MSTPD6	MSTPD5	MSTPD4	MSTPD3	MSTPD2	MSTPD1	MSTPD0
Initial value :		1	1	Undefined	Undefined	Undefined	Undefined	Undefined	Undefined
R/W	:	R/W	R/W	—	—	—	—	—	—

MSTPCR, comprising four 8-bit readable/writable registers, performs module stop mode control.

MSTPCRA to MSTPCRC are initialized to H'3FFFFFF by a reset and in hardware standby mode. MSTPCRD is initialized to B'11***** by a reset and in hardware standby mode. They are not initialized in software standby mode.

MSTPCRA/MSTPCRB/MSTPCRC Bits 7 to 0, MSTPCRD Bits 7 and 6—Module Stop (MSTPA7 to MSTPA0, MSTPB7 to MSTPB0, MSTPC7 to MSTPC0, MSTPD7 and MSTPD6): These bits specify module stop mode. See table 23A-4 for the method of selecting the on-chip peripheral functions.

**MSTPCRA/MSTPCRB/
MSTPCRC Bits 7 to 0,
MSTPCRD Bits 7 and 6**

**MSTPA7 to MSTPA0,
MSTPB7 to MSTPB0,
MSTPC7 to MSTPC0,
MSTPD7 and MSTPD6** Description

0	Module stop mode is cleared (initial value of MSTPA7 and MSTPA6)
1	Module stop mode is set (initial value of MSTPA5–0, MSTPB7–0, MSTPC7–0, and MSTPC7, 6)

23A.3 Medium-Speed Mode

In high-speed mode, when the SCK2 to SCK0 bits in SCKCR are set to 1, the operating mode changes to medium-speed mode as soon as the current bus cycle ends. In medium-speed mode, the CPU operates on the operating clock ($\phi/2$, $\phi/4$, $\phi/8$, $\phi/16$, or $\phi/32$) specified by the SCK2 to SCK0 bits. The bus masters other than the CPU (DTC) also operate in medium-speed mode. On-chip supporting modules other than the bus masters always operate on the high-speed clock (ϕ).

In medium-speed mode, a bus access is executed in the specified number of states with respect to the bus master operating clock. For example, if $\phi/4$ is selected as the operating clock, on-chip memory is accessed in 4 states, and internal I/O registers in 8 states.

Medium-speed mode is cleared by clearing all of bits SCK2 to SCK0 to 0. A transition is made to high-speed mode and medium-speed mode is cleared at the end of the current bus cycle.

If a SLEEP instruction is executed when the SSBY bit in SBYCR is cleared to 0, and LSON bit in LPWRCR is cleared to 0, a transition is made to sleep mode. When sleep mode is cleared by an interrupt, medium-speed mode is restored.

When the SLEEP instruction is executed with the SSBY bit = 1, LPWRCR LSON bit = 0, and TCSR (WDT1) PSS bit = 0, operation shifts to the software standby mode. When software standby mode is cleared by an external interrupt, medium-speed mode is restored.

When the $\overline{\text{RES}}$ pin is set low and medium-speed mode is cancelled, operation shifts to the reset state. The same applies in the case of a reset caused by overflow of the watchdog timer.

When the $\overline{\text{STBY}}$ pin is driven low, a transition is made to hardware standby mode.

Figure 23A-2 shows the timing for transition to and clearance of medium-speed mode.

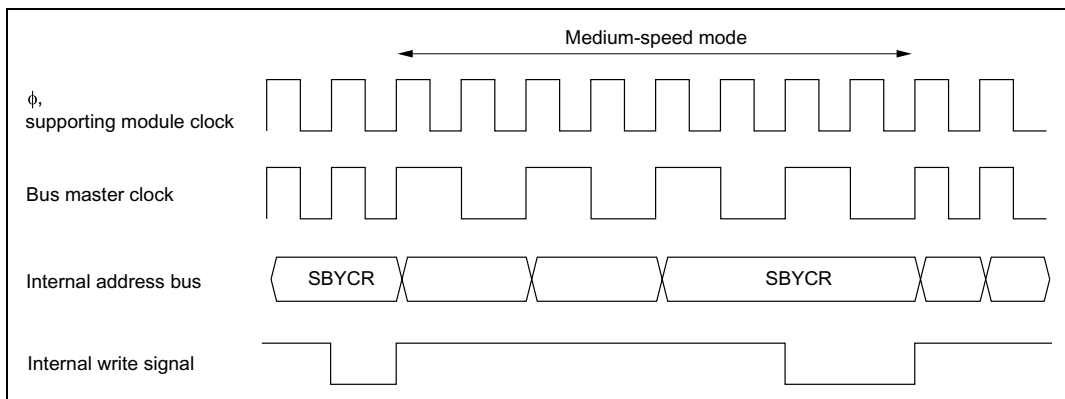

Figure 23A-2 Medium-Speed Mode Transition and Clearance Timing

23A.4 Sleep Mode

23A.4.1 Sleep Mode

When the SLEEP instruction is executed when the SBYCR SSBY bit = 0 and the LPWRCR LSON bit = 0, the CPU enters the sleep mode. In sleep mode, CPU operation stops but the contents of the CPU's internal registers are retained. Other supporting modules do not stop.

23A.4.2 Exiting Sleep Mode

Sleep mode is exited by any interrupt, or signals at the $\overline{\text{RES}}$, or $\overline{\text{STBY}}$ pins.

Exiting Sleep Mode by Interrupts: When an interrupt occurs, sleep mode is exited and interrupt exception processing starts. Sleep mode is not exited if the interrupt is disabled, or interrupts other than NMI are masked by the CPU.

Exiting Sleep Mode by $\overline{\text{RES}}$ pin: Setting the $\overline{\text{RES}}$ pin level Low selects the reset state. After the stipulated reset input duration, driving the $\overline{\text{RES}}$ pin High starts the CPU performing reset exception processing.

Exiting Sleep Mode by $\overline{\text{STBY}}$ Pin: When the $\overline{\text{STBY}}$ pin level is driven Low, a transition is made to hardware standby mode.

23A.5 Module Stop Mode

23A.5.1 Module Stop Mode

Module stop mode can be set for individual on-chip supporting modules.

When the corresponding MSTP bit in MSTPCR is set to 1, module operation stops at the end of the bus cycle and a transition is made to module stop mode. The CPU continues operating independently.

Table 23A-4 shows MSTP bits and the corresponding on-chip supporting modules.

When the corresponding MSTP bit is cleared to 0, module stop mode is cleared and the module starts operating at the end of the bus cycle. In module stop mode, the internal states of modules other than the SCI, Motor control PWM, A/D converter and HCAN are retained.

After reset clearance, all modules other than DTC are in module stop mode.

When an on-chip supporting module is in module stop mode, read/write access to its registers is disabled.

Table 23A-4 MSTP Bits and Corresponding On-Chip Supporting Modules

Register	Bit	Module
MSTPCRA	MSTPA6	Data transfer controller (DTC)
	MSTPA5	16-bit timer pulse unit (TPU)
	MSTPA3	Programmable pulse generator (PPG)
	MSTPA2	D/A converter (channel 0, 1)
	MSTPA1	A/D converter
	MSTPA0*1	
MSTPCRB	MSTPB7	Serial communication interface 0 (SCI0)
	MSTPB6	Serial communication interface 1 (SCI1)
	MSTPB5	Serial communication interface 2 (SCI2)
	MSTPB4*2	
	MSTPB3*2	
	MSTPB0*1	
MSTPCRC	MSTPC4	PC break controller (PBC)
	MSTPC3	HCAN0
	MSTPC2	HCAN1
	MSTPC1*1	
	MSTPC0*1	
MSTPCRD	MSTPD7	Motor control PWM (PWM)
	MSTPD6*1	

- Notes: 1. MSTPA0, MSTPB0 and MSTPC1 to MSTPC0 and MSTPD6 are readable/writable bits with an initial value of 1.
2. The I²C bus interface is available as an option in the H8S/2638 and H8S/2630. In the H8S/2636, MSTB4 and MSTB3 are readable and writable bits that have 1 as their initial value.

23A.5.2 Usage Notes

DTC Module Stop: Depending on the operating status of the DTC, the MSTPA7 and MSTPA6 bits may not be set to 1. Setting of the DTC module stop mode should be carried out only when the respective module is not activated.

For details, refer to section 8, Data Transfer Controller (DTC).

On-Chip Supporting Module Interrupt: Relevant interrupt operations cannot be performed in module stop mode. Consequently, if module stop mode is entered when an interrupt has been requested, it will not be possible to clear the CPU interrupt source or the DTC activation source. Interrupts should therefore be disabled before entering module stop mode.

Writing to MSTPCR: MSTPCR should only be written to by the CPU.

23A.6 Software Standby Mode

23A.6.1 Software Standby Mode

A transition is made to software standby mode when the SLEEP instruction is executed when the SBYCR SSBY bit = 1 and the LPWRCR LSON bit = 0, and the TCSR (WDT1) PSS bit = 0. In this mode, the CPU, on-chip supporting modules, and oscillator all stop. However, the contents of the CPU's internal registers, RAM data, and the states of on-chip supporting modules other than the SCI, A/D converter, Motor control, PWM, HCAN and I/O ports, are retained. Whether the address bus and bus control signals are placed in the high-impedance state.

In this mode the oscillator stops, and therefore power dissipation is significantly reduced.

23A.6.2 Clearing Software Standby Mode

Software standby mode is cleared by an external interrupt (NMI pin, or pins $\overline{\text{IRQ0}}$ to $\overline{\text{IRQ5}}$), or by means of the $\overline{\text{RES}}$ pin or $\overline{\text{STBY}}$ pin.

- Clearing with an interrupt

When an NMI or IRQ0 to IRQ5 interrupt request signal is input, clock oscillation starts, and after the elapse of the time set in bits STS2 to STS0 in SYSCR, stable clocks are supplied to the entire chip, software standby mode is cleared, and interrupt exception handling is started.

When clearing software standby mode with an IRQ0 to IRQ5 interrupt, set the corresponding enable bit to 1 and ensure that no interrupt with a higher priority than interrupts IRQ0 to IRQ5 is generated. Software standby mode cannot be cleared if the interrupt has been masked on the CPU side or has been designated as a DTC activation source.

- Clearing with the $\overline{\text{RES}}$ pin

When the $\overline{\text{RES}}$ pin is driven low, clock oscillation is started. At the same time as clock oscillation starts, clocks are supplied to the entire chip. Note that the $\overline{\text{RES}}$ pin must be held low until clock oscillation stabilizes. When the RES pin goes high, the CPU begins reset exception handling.

- Clearing with the $\overline{\text{STBY}}$ pin

When the $\overline{\text{STBY}}$ pin is driven low, a transition is made to hardware standby mode.

23A.6.3 Setting Oscillation Stabilization Time after Clearing Software Standby Mode

Bits STS2 to STS0 in SBYCR should be set as described below.

Using a Crystal Oscillator: Set bits STS2 to STS0 so that the standby time is at least 8 ms (the oscillation stabilization time).

Table 23A-5 shows the standby times for different operating frequencies and settings of bits STS2 to STS0.

Table 23A-5 Oscillation Stabilization Time Settings

STS2	STS1	STS0	Standby Time	20 MHz	16 MHz	12 MHz	10 MHz	8 MHz	6 MHz	4 MHz	Unit
0	0	0	8192 states	0.41	0.51	0.68	0.8	1.0	1.3	2.0	ms
		1	16384 states	0.82	1.0	1.3	1.6	2.0	2.7	4.1	
	1	0	32768 states	1.6	2.0	2.7	3.3	4.1	5.5	8.2	
		1	65536 states	3.3	4.1	5.5	6.6	8.2	10.9	16.4	
1	0	0	131072 states	6.6	8.2	10.9	13.1	16.4	21.8	32.8	
		1	262144 states	13.1	16.4	21.8	26.2	32.8	43.6	65.6	
	1	0	Reserved	—	—	—	—	—	—	—	μs
		1	16 states (Setting prohibited)	0.8	1.0	1.3	1.6	2.0	2.6	4.0	

 : Recommended time setting

Using an External Clock: The PLL circuit requires time to stabilize, so the standby time should be set to a value of 2 ms or more.

23A.6.4 Software Standby Mode Application Example

Figure 23A-3 shows an example in which a transition is made to software standby mode at the falling edge on the NMI pin, and software standby mode is cleared at the rising edge on the NMI pin.

In this example, an NMI interrupt is accepted with the NMIEG bit in SYSCR cleared to 0 (falling edge specification), then the NMIEG bit is set to 1 (rising edge specification), the SSBY bit is set to 1, and a SLEEP instruction is executed, causing a transition to software standby mode.

Software standby mode is then cleared at the rising edge on the NMI pin.

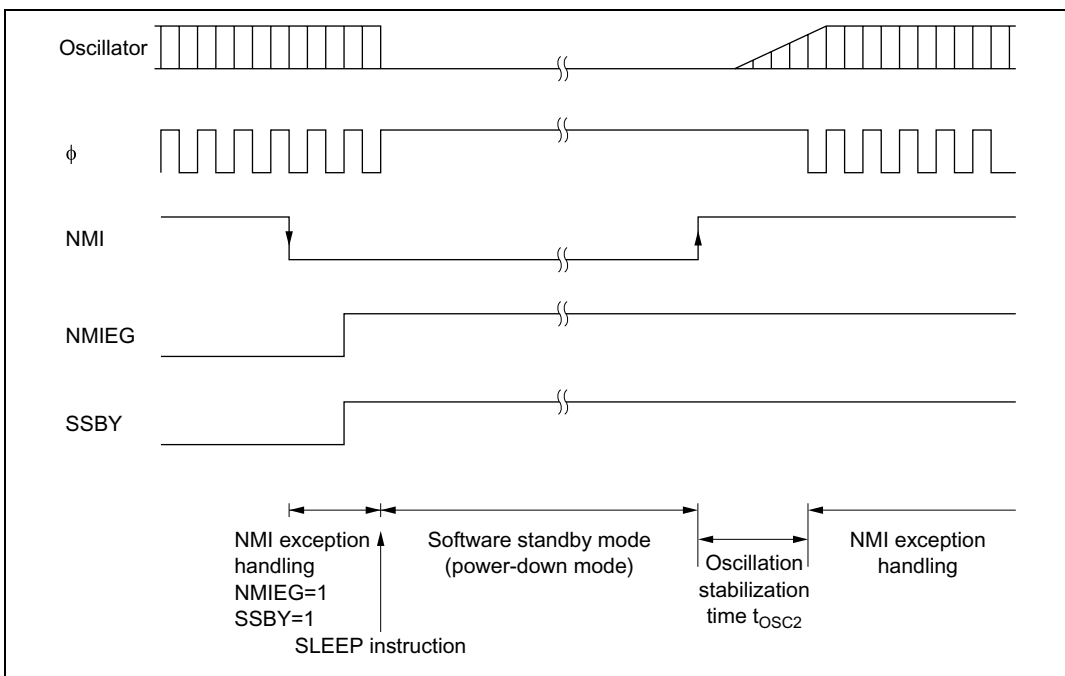

Figure 23A-3 Software Standby Mode Application Example

23A.6.5 Usage Notes

I/O Port Status: In software standby mode, I/O port states are retained. If the OPE bit is set to 1, the address bus and bus control signal output is also retained. Therefore, there is no reduction in current dissipation for the output current when a high-level signal is output.

Current Dissipation during Oscillation Stabilization Wait Period: Current dissipation increases during the oscillation stabilization wait period.

Write Data Buffer Function: The write data buffer function and software standby mode cannot be used at the same time. When the write data buffer function is used, the WDBE bit in BCRL should be cleared to 0 to cancel the write data buffer function before entering software standby mode. Also check that external writes have finished, by reading external addresses, etc., before executing a SLEEP instruction to enter software standby mode. See section 7.7, Write Data Buffer Function, for details of the write data buffer function.

23A.7 Hardware Standby Mode

23A.7.1 Hardware Standby Mode

When the $\overline{\text{STBY}}$ pin is driven low, a transition is made to hardware standby mode from any mode.

In hardware standby mode, all functions enter the reset state and stop operation, resulting in a significant reduction in power dissipation. As long as the prescribed voltage is supplied, on-chip RAM data is retained. I/O ports are set to the high-impedance state.

In order to retain on-chip RAM data, the RAME bit in SYSCR should be cleared to 0 before driving the $\overline{\text{STBY}}$ pin low.

Do not change the state of the mode pins (MD2 to MD0) while the chip is in hardware standby mode.

Hardware standby mode is cleared by means of the $\overline{\text{STBY}}$ pin and the $\overline{\text{RES}}$ pin. When the $\overline{\text{STBY}}$ pin is driven high while the $\overline{\text{RES}}$ pin is low, the reset state is set and clock oscillation is started. Ensure that the $\overline{\text{RES}}$ pin is held low until the clock oscillator stabilizes (at least 8 ms—the oscillation stabilization time—when using a crystal oscillator). When the $\overline{\text{RES}}$ pin is subsequently driven high, a transition is made to the program execution state via the reset exception handling state.

23A.7.2 Hardware Standby Mode Timing

Figure 23A-4 shows an example of hardware standby mode timing.

When the $\overline{\text{STBY}}$ pin is driven low after the $\overline{\text{RES}}$ pin has been driven low, a transition is made to hardware standby mode. Hardware standby mode is cleared by driving the $\overline{\text{STBY}}$ pin high, waiting for the oscillation stabilization time, then changing the $\overline{\text{RES}}$ pin from low to high.

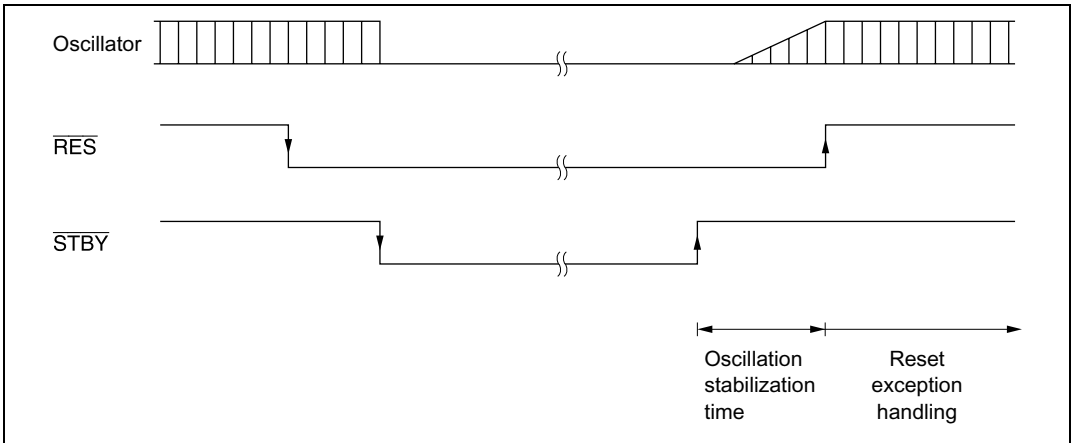

Figure 23A-4 Hardware Standby Mode Timing

23A.8 ϕ Clock Output Disabling Function

Output of the ϕ clock can be controlled by means of the PSTOP bit in SCKCR, and DDR for the corresponding port. When the PSTOP bit is set to 1, the ϕ clock stops at the end of the bus cycle, and ϕ output goes high. ϕ clock output is enabled when the PSTOP bit is cleared to 0. When DDR for the corresponding port is cleared to 0, ϕ clock output is disabled and input port mode is set. Table 23A-6 shows the state of the ϕ pin in each processing state.

Using the on-chip PLL circuit to lower the oscillator frequency or prohibiting external ϕ clock output also have the effect of reducing unwanted electromagnetic interference*. Therefore, consideration should be given to these options when deciding on system board settings.

Note: * Electromagnetic interference: EMI (Electro Magnetic Interference)

Table 23A-6 ϕ Pin State in Each Processing State

DDR	0	1	1
PSTOP	—	0	1
Hardware standby mode	High impedance	High impedance	High impedance
Software standby	High impedance	Fixed high	Fixed high
Sleep mode	High impedance	ϕ output	Fixed high
High-speed mode, medium-speed mode	High impedance	ϕ output	Fixed high

Section 23B Power-Down Modes

[HD64F2636UF, HD6432636UF,
HD64F2638UF, HD6432638UF, HD64F2638WF,
HD6432638WF, HD64F2639UF, HD6432639UF,
HD64F2639WF, HD6432639WF,
HD64F2630UF, HD6432630UF,
HD64F2630WF, HD6432630WF,
HD6432635F, HD64F2635F, HD6432634F]

Note: The DTC, PBC, PPB, and D/A converter are not implemented in the H8S/2635 and H8S/2634.

23B.1 Overview

In addition to the normal program execution state, the chip has nine power-down modes in which operation of the CPU and oscillator is halted and power dissipation is reduced. Low-power operation can be achieved by individually controlling the CPU, on-chip supporting modules, and so on.

The chip operating modes are as follows:

- (1) High-speed mode
- (2) Medium-speed mode
- (3) Subactive mode* (U-mask, W-mask version, H8S/2635 Group only)
- (4) Sleep mode
- (5) Subsleep mode* (U-mask, W-mask version, H8S/2635 Group only)
- (6) Watch mode* (U-mask, W-mask version, H8S/2635 Group only)
- (7) Module stop mode
- (8) Software standby mode
- (9) Hardware standby mode

(2) to (9) are low power dissipation states. Sleep mode and subsleep mode are CPU states, medium-speed mode is a CPU and bus master state, subactive mode is a CPU and bus master and internal peripheral function state, and module stop mode is an internal peripheral function (including bus masters other than the CPU) state. Some of these states can be combined.

After a reset, the LSI is in high-speed mode with modules other than the DTC in module stop mode.

Note: * Subclock functions (subactive mode, subsleep mode, and watch mode) are available in the U-mask and W-mask versions, and H8S/2635 Group only.

These functions cannot be used with the other versions.

Tables 23B-1 and 23B-2 show the internal state of the LSI in the respective modes. Table 23B-3 shows the conditions for shifting between the low power dissipation modes.

Figure 23B-1 is a mode transition diagram.

Table 23B-1 LSI Internal States in Each Mode (H8S/2636, H8S/2638, H8S/2630)

Function		High-Speed	Medium-Speed	Sleep	Module Stop	Watch	Sub-active	Subsleep	Software Standby	Hardware Standby
System clock pulse generator		Functioning	Functioning	Functioning	Functioning	Halted	Halted	Halted	Halted	Halted
Subclock pulse generator		Functioning ^{*1}	Functioning ^{*1}	Functioning ^{*1}	Functioning ^{*1}	Functioning ^{*1}	Functioning ^{*1}	Functioning ^{*1}	Functioning ^{*1}	Halted
CPU	Instructions Registers	Functioning	Medium-speed operation	Halted (retained)	High/medium-speed operation	Halted (retained)	Subclock operation	Halted (retained)	Halted (retained)	Halted (undefined)
External interrupts	NMI	Functioning	Functioning	Functioning	Functioning	Functioning	Functioning	Functioning	Functioning	Halted
	IRQ0 to IRQ5	Functioning	Functioning	Functioning	Functioning	Functioning	Functioning	Functioning	Functioning	Halted
Peripheral functions	WDT1	Functioning	Functioning	Functioning	—	Subclock operation	Subclock operation	Subclock operation	Halted (retained)	Halted (reset)
	WDT0	Functioning	Functioning	Functioning	—	Halted (retained)	Subclock operation	Subclock operation	Halted (retained)	Halted (reset)
	DTC	Functioning	Medium-speed operation	Functioning	Halted (retained)	Halted (retained)	Halted (retained)	Halted (retained)	Halted (retained)	Halted (reset)
	PBC	Functioning	Medium-speed operation	Functioning	Halted (retained)	Halted (retained)	Subclock operation	Halted (retained)	Halted (retained)	Halted (reset)
	TPU	Functioning	Functioning	Functioning	Halted (retained)	Halted (retained)	Halted (retained)	Halted (retained)	Halted (retained)	Halted (reset)
	IIC0 ^{*2}	Functioning	Functioning	Functioning	Halted (retained)	Halted (retained)	Halted (retained)	Halted (retained)	Halted (retained)	Halted (reset)
	IIC1 ^{*2}	Functioning	Functioning	Functioning	Halted (retained)	Halted (retained)	Halted (retained)	Halted (retained)	Halted (retained)	Halted (reset)
	PPG	Functioning	Functioning	Functioning	Halted (retained)	Halted (retained)	Halted (retained)	Halted (retained)	Halted (retained)	Halted (reset)
	D/A0, 1	Functioning	Functioning	Functioning	Halted (retained)	Halted (retained)	Halted (retained)	Halted (retained)	Halted (retained)	Halted (reset)
	SCI0	Functioning	Functioning	Functioning	Halted (reset)	Halted (reset)	Halted (reset)	Halted (reset)	Halted (reset)	Halted (reset)
SCI1	Functioning	Functioning	Functioning	Halted (reset)	Halted (reset)	Halted (reset)	Halted (reset)	Halted (reset)	Halted (reset)	
SCI2	Functioning	Functioning	Functioning	Halted (reset)	Halted (reset)	Halted (reset)	Halted (reset)	Halted (reset)	Halted (reset)	
PWM	Functioning	Functioning	Functioning	Halted (reset)	Halted (reset)	Halted (reset)	Halted (reset)	Halted (reset)	Halted (reset)	
A/D	Functioning	Functioning	Functioning	Halted (reset)	Halted (reset)	Halted (reset)	Halted (reset)	Halted (reset)	Halted (reset)	
RAM	Functioning	Functioning	Functioning (DTC)	Functioning	Retained	Functioning	Retained	Retained	Retained	Retained
I/O	Functioning	Functioning	Functioning	Functioning	Retained	Functioning	Retained	Retained	Retained	High impedance
HCAN	Functioning	Functioning	Functioning	Halted (reset)	Halted (reset)	Halted (reset)	Halted (reset)	Halted (reset)	Halted (reset)	Halted (reset)

Notes: "Halted (retained)" means that internal register values are retained. The internal state is "operation suspended."

"Halted (reset)" means that internal register values and internal states are initialized.

In module stop mode, only modules for which a stop setting has been made are halted (reset or retained).

1. Halted if the SUBSTP bit in LPWRCR is set to 1.

2. The I²C bus interface is available as an option in the H8S/2638, H8S/2639, and H8S/2630.

The product equipped with the I²C bus interface is the W-mask version.

Table 23B-2 LSI Internal States in Each Mode (H8S/2639 Group, H8S/2635 Group)

Function	High-Speed	Medium-Speed	Sleep	Module Stop	Watch	Sub-active	Subsleep	Software Standby	Hardware Standby	
System clock (ϕ)	Functioning	Functioning	Functioning	Functioning	Halted	Halted	Halted	Halted	Halted	
Clock pulse generator	Functioning	Functioning	Functioning	Functioning	Functioning ^{*1}	Functioning ^{*1}	Functioning ^{*1}	Functioning ^{*1}	Halted	
Subclock (ϕ Sub)	Functioning ^{*1}	Functioning ^{*1}	Functioning ^{*1}	Functioning ^{*1}	Functioning ^{*1}	Functioning ^{*1}	Functioning ^{*1}	Functioning ^{*1}	Halted	
CPU	Instructions Registers	Functioning	Medium-speed operation	Halted (retained)	High/medium-speed operation	Halted (retained)	Subclock operation (retained)	Halted (retained)	Halted (undefined)	
External interrupts	NMI IRQ0 to IRQ5	Functioning	Functioning	Functioning	Functioning	Functioning	Functioning	Functioning	Halted	
Peripheral functions	WDT1	Functioning	Functioning	Functioning	—	Subclock operation	Subclock operation	Subclock operation	Halted (retained)	Halted (reset)
	WDT0	Functioning	Functioning	Functioning	—	Halted (retained)	Subclock operation	Subclock operation	Halted (retained)	Halted (reset)
	DTC ^{*3}	Functioning	Medium-speed operation	Functioning	Halted (retained)	Halted (retained)	Halted (retained)	Halted (retained)	Halted (retained)	Halted (reset)
	TPU	Functioning	Functioning	Functioning	Halted (retained)	Halted (retained)	Halted (retained)	Halted (retained)	Halted (retained)	Halted (reset)
	IIC0 ^{*2}									
	IIC1 ^{*2}									
	PBC ^{*3}									
	PPG ^{*3}									
	D/A0, 1 ^{*3}									
	SCI0	Functioning	Functioning	Functioning	Halted (reset)	Halted (reset)	Halted (reset)	Halted (reset)	Halted (reset)	Halted (reset)
SCI1										
SCI2										
PWM										
A/D										
RAM	Functioning	Functioning	Functioning (DTC)	Functioning	Retained	Functioning	Retained	Retained	Retained	
I/O	Functioning	Functioning	Functioning	Functioning	Retained	Functioning	Retained	Retained	High impedance	
HCAN	Functioning	Functioning	Functioning	Halted (reset)	Halted (reset)	Halted (reset)	Halted (reset)	Halted (reset)	Halted (reset)	

Notes: "Halted (retained)" means that internal register values are retained. The internal state is "operation suspended."

"Halted (reset)" means that internal register values and internal states are initialized.

In module stop mode, only modules for which a stop setting has been made are halted (reset or retained).

1. Halted if the SUBSTP bit in LPWRCR is set to 1.
2. The I²C bus interface is available as an option in the H8S/2638, H8S/2639, and H8S/2630. The product equipped with the I²C bus interface is the W-mask version.
3. The DTC, PBC, PPG, DA0, and DA1 are not implemented in the H8S/2635 and H8S/2634.

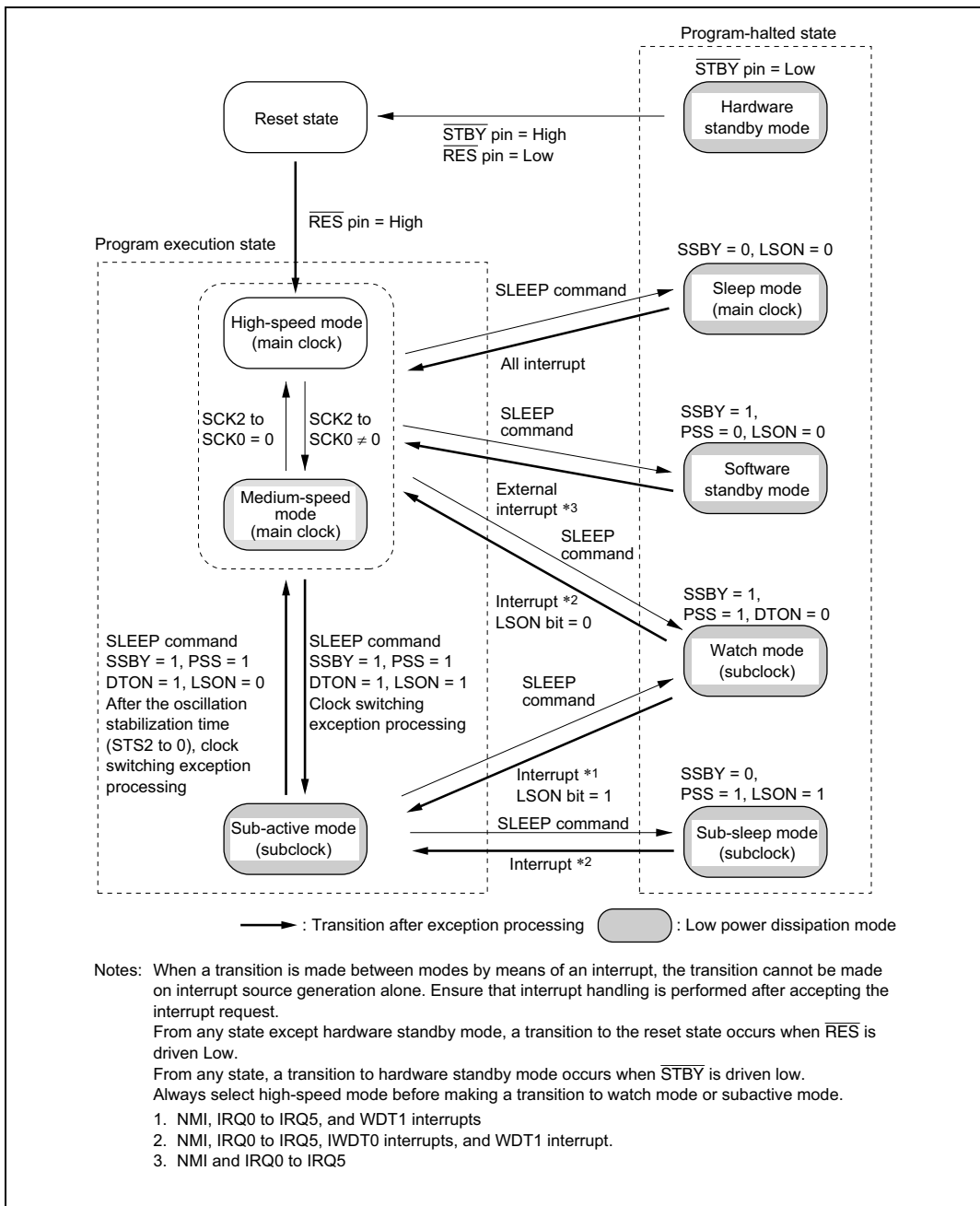

Figure 23B-1 Mode Transition Diagram

Table 23B.3 Low Power Dissipation Mode Transition Conditions

Pre-Transition State	Status of Control Bit at Transition				State after Transition Invoked by SLEEP Command	State after Transition Back from Low Power Mode Invoked by Interrupt
	SSBY	PSS	LSON	DTON		
High-speed/ Medium-speed	0	*	0	*	Sleep	High-speed/Medium-speed
	0	*	1	*	—	—
	1	0	0	*	Software standby	High-speed/Medium-speed
	1	0	1	*	—	—
	1	1	0	0	Watch	High-speed
	1	1	1	0	Watch	Subactive
	1	1	0	1	—	—
	1	1	1	1	Subactive	—
	Subactive	0	0	*	*	—
0		1	0	*	—	—
0		1	1	*	Subsleep	Subactive
1		0	*	*	—	—
1		1	0	0	Watch	High-speed
1		1	1	0	Watch	Subactive
1		1	0	1	High-speed	—
1		1	1	1	—	—

Legend:

*: Don't care

—: Do not set

23B.1.1 Register Configuration

Power-down modes are controlled by the SBYCR, SCKCR, LPWRCR, TCSR (WDT1), and MSTPCR registers. Table 23B-4 summarizes these registers.

Table 23B-4 Power-Down Mode Registers

Name	Abbreviation	R/W	Initial Value	Address* ¹
Standby control register	SBYCR	R/W	H'58	H'FDE4
System clock control register	SCKCR	R/W	H'00	H'FDE6
Low-power control register	LPWRCR	R/W	H'00	H'FDEC
Timer control/status register	TCSR	R/W	H'00	H'FFA2
Module stop control register A, B, C, D	MSTPCRA	R/W	H'3F	H'FDE8
	MSTPCRB	R/W	H'FF	H'FDE9
	MSTPCRC	R/W	H'FF	H'FDEA
	MSTPCRD	R/W	B'11*****	H'FC60

Note: 1. Lower 16 bits of the address.

23B.2 Register Descriptions

23B.2.1 Standby Control Register (SBYCR)

Bit	:	7	6	5	4	3	2	1	0
		SSBY	STS2	STS1	STS0	OPE	—	—	—
Initial value	:	0	1	0	1	1	0	0	0
R/W	:	R/W	R/W	R/W	R/W	R/W	—	—	—

SBYCR is an 8-bit readable/writable register that performs power-down mode control.

SBYCR is initialized to H'58 by a reset and in hardware standby mode. It is not initialized in software standby mode.

Bit 7—Software Standby (SSBY): When making a low power dissipation mode transition by executing the SLEEP instruction, the operating mode is determined in combination with other control bits.

Note that the value of the SSBY bit does not change even when shifting between modes using interrupts.

Bit 7

SSBY	Description
0	Shifts to sleep mode when the SLEEP instruction is executed in high-speed mode or medium-speed mode. Shifts to subsleep mode when the SLEEP instruction is executed in subactive mode. (Initial value)
1	Shifts to software standby mode, subactive mode, and watch mode when the SLEEP instruction is executed in high-speed mode or medium-speed mode. Shifts to watch mode or high-speed mode when the SLEEP instruction is executed in subactive mode.

Bits 6 to 4—Standby Timer Select 2 to 0 (STS2 to STS0): These bits select the MCU wait time for clock stabilization when shifting to high-speed mode or medium-speed mode by using a specific interrupt or command to cancel software standby mode, watch mode, or subactive mode. With a quartz oscillator (Table 23B-6), select a wait time of 8ms (oscillation stabilization time) or more, depending on the operating frequency. With an external clock, select a standby time of 2 ms or more (PLL oscillator settling time), based on the operating frequency.

Bit 6	Bit 5	Bit 4	Description
STS2	STS1	STS0	
0	0	0	Standby time = 8192 states
		1	Standby time = 16384 states
	1	0	Standby time = 32768 states
		1	Standby time = 65536 states
1	0	0	Standby time = 131072 states
		1	Standby time = 262144 states (Initial value)
	1	0	Reserved
		1	Standby time = 16 states (Setting prohibited)

Bit 3—Output Port Enable (OPE): This bit specifies whether the output of the address bus and bus control signals (\overline{AS} , \overline{RD} , \overline{HWR} , \overline{LWR}) is retained or set to high-impedance state in the software standby mode, watch mode, and when making a direct transition.

Bit 3

OPE	Description
0	In software standby mode, watch mode, and when making a direct transition, address bus and bus control signals are high-impedance.
1	In software standby mode, watch mode, and when making a direct transition, the output state of the address bus and bus control signals is retained. (Initial value)

Bits 2 to 0—Reserved: These bits always return 0 when read, and cannot be written to.

23B.2.2 System Clock Control Register (SCKCR)

Bit	:	7	6	5	4	3	2	1	0
		PSTOP	—	—	—	STCS	SCK2	SCK1	SCK0
Initial value	:	0	0	0	0	0	0	0	0
R/W	:	R/W	—	—	—	R/W	R/W	R/W	R/W

SCKCR is an 8-bit readable/writable register that performs ϕ clock output control and medium-speed mode control.

SCKCR is initialized to H'00 by a reset and in hardware standby mode. It is not initialized in software standby mode.

Bit 7— ϕ Clock Output Disable (PSTOP): In combination with the DDR of the applicable port, this bit controls ϕ output. See section 23B.12, ϕ Clock Output Disable Function for details.

		Description			
Bit 7	PSTOP	High-Speed Mode, Medium-Speed Mode, Subactive Mode	Sleep Mode, Subsleep Mode	Software Standby Mode, Watch Mode, Direct Transition	Hardware Standby Mode
0		ϕ output (initial value)	ϕ output	Fixed high	High impedance
1		Fixed high	Fixed high	Fixed high	High impedance

Bits 6 to 4—Reserved: These bits are always read as 0 and cannot be modified.

Bit 3—Frequency Multiplication Factor Switching Mode Select (STCS): Selects the operation when the PLL circuit frequency multiplication factor is changed.

Bit 3

STCS	Description
0	Specified multiplication factor is valid after transition to software standby mode, watch mode, or subactive mode (Initial value)
1	Specified multiplication factor is valid immediately after STC bits are rewritten

Bits 2 to 0—System Clock Select (SCK2 to SCK0): These bits select the bus master clock in high-speed mode, medium-speed mode, and subactive mode.

Set SCK2 to SCK0 all to 0 when shifting to operation in watch mode or subactive mode.

Bit 2	Bit 1	Bit 0	Description
SCK2	SCK1	SCK0	
0	0	0	Bus master in high-speed mode (Initial value)
		1	Medium-speed clock is $\phi/2$
	1	0	Medium-speed clock is $\phi/4$
1		Medium-speed clock is $\phi/8$	
1	0	0	Medium-speed clock is $\phi/16$
		1	Medium-speed clock is $\phi/32$
	1	—	—

23B.2.3 Low-Power Control Register (LPWRCR)

Bit	:	7	6	5	4	3	2	1	0
		DTON*	LSON*	NESEL*	SUBSTP*	RFCUT*	—	STC1	STC0
Initial value	:	0	0	0	0	0	0	0	0
R/W	:	R/W	R/W	R/W	R/W	R/W	R/W	R/W	R/W

Note: * Bits 7 to 3 in LPWRCR are valid in the U-mask and W-mask versions, and H8S/2635 Group; they are reserved bits in all other versions.
See section 23A.2.3, Low-Power Control Register (LPWRCR), for more information.

The LPWRCR is an 8-bit read/write register that controls the low power dissipation modes.

The LPWRCR is initialized to H'00 at a reset and when in hardware standby mode. It is not initialized in software standby mode. The following describes bits 7 to 2. For details of other bits, see sections 22A.2.2, 22B.2.2, Low-Power Control Register (LPWRCR).

Bit 7—Direct Transition ON Flag (DTON): When shifting to low power dissipation mode by executing the SLEEP instruction, this bit specifies whether or not to make a direct transition between high-speed mode or medium-speed mode and the subactive modes. The selected operating mode after executing the SLEEP instruction is determined by the combination of other control bits.

Bit 7

DTON	Description
0	<ul style="list-style-type: none"> When the SLEEP instruction is executed in high-speed mode or medium-speed mode, operation shifts to sleep mode, software standby mode, or watch mode*. When the SLEEP instruction is executed in subactive mode, operation shifts to subsleep mode or watch mode. (Initial value)
1	<ul style="list-style-type: none"> When the SLEEP instruction is executed in high-speed mode or medium-speed mode, operation shifts directly to subactive mode*, or shifts to sleep mode or software standby mode. When the SLEEP instruction is executed in subactive mode, operation shifts directly to high-speed mode, or shifts to subsleep mode.

Note: * Always set high-speed mode when shifting to watch mode or subactive mode.

Bit 6—Low-Speed ON Flag (LSON): When shifting to low power dissipation mode by executing the SLEEP instruction, this bit specifies the operating mode, in combination with other control bits. This bit also controls whether to shift to high-speed mode or subactive mode when watch mode is cancelled.

Bit 6

LSON	Description
0	<ul style="list-style-type: none"> When the SLEEP instruction is executed in high-speed mode or medium-speed mode, operation shifts to sleep mode, software standby mode, or watch mode*. When the SLEEP instruction is executed in subactive mode, operation shifts to watch mode or shifts directly to high-speed mode. Operation shifts to high-speed mode when watch mode is cancelled. (Initial value)
1	<ul style="list-style-type: none"> When the SLEEP instruction is executed in high-speed mode, operation shifts to watch mode or subactive mode. When the SLEEP instruction is executed in subactive mode, operation shifts to subsleep mode or watch mode. Operation shifts to subactive mode when watch mode is cancelled.

Note: * Always set high-speed mode when shifting to watch mode or subactive mode.

Bit 5—Noise Elimination Sampling Frequency Select (NESEL): This bit selects the sampling frequency of the subclock (ϕ_{SUB}) generated by the subclock oscillator is sampled by the clock (ϕ) generated by the system clock oscillator. Set this bit to 0 when $\phi=5\text{MHz}$ or more. This setting is disabled in subactive mode, subsleep mode, and watch mode.

Bit 5

NESEL	Description
0	Sampling using $1/32 \times \phi$ (Initial value)
1	Sampling using $1/4 \times \phi$

Bit 4—Subclock Enable (SUBSTP): This bit enables/disables subclock generation.

Bit 4

SUBSTP	Description
0	Enables subclock generation (Initial value)
1	Disables subclock generation

Bit 3—Oscillation Circuit Feedback Resistance Control Bit (RFCUT): This bit turns the internal feedback resistance of the main clock oscillation circuit ON/OFF.

Bit 3

RFCUT Description

0	When the main clock is oscillating, sets the feedback resistance ON. When the main clock is stopped, sets the feedback resistance OFF. (Initial value)
1	Sets the feedback resistance OFF.

Bit 2—Reserved: Only write 0 to this bit.

23B.2.4 Timer Control/Status Register (TCSR)

Bit	:	7	6	5	4	3	2	1	0
		OVF	WT/I \bar{T}	TME	PSS*2	RST/NMI	CKS2	CKS1	CKS0
Initial value	:	0	0	0	0	0	0	0	0
R/W	:	R/(W)*1	R/W	R/W	R/W	R/W	R/W	R/W	R/W

- Notes: 1. Only write 0 to clear the flag.
 2. Bit 4 (PSS) in TCSR of WDT1 is valid in the U-mask and W-mask versions, and H8S/2635 Group. In versions other than the U-mask and W-mask versions, and H8S/2635 Group, however, the PSS bit must always be written with 0 since no subclock functions are available.

TCSR is an 8-bit read/write register that selects the clock input to WDT1 TCNT and the mode.

Here, we describe bit 4. For details of the other bits in this register, see section 12.2.2, Timer Control/Status Register (TCSR).

The TCSR is initialized to H'00 at a reset and when in hardware standby mode. It is not initialized in software standby mode.

Bit 4—Prescaler Select (PSS): This bit selects the clock source input to WDT1 TCNT.

It also controls operation when shifting low power dissipation modes. The operating mode selected after the SLEEP instruction is executed is determined in combination with other control bits.

For details, see the description for clock selection in section 12.2.2, Timer Control/Status Register (TCSR), and this section.

Bit 4

PSS	Description
0	<ul style="list-style-type: none">• TCNT counts the divided clock from the ϕ-based prescaler (PSM).• When the SLEEP instruction is executed in high-speed mode or medium-speed mode, operation shifts to sleep mode or software standby mode. (Initial value)
1	<ul style="list-style-type: none">• TCNT counts the divided clock from the ϕsubclock-based prescaler (PSS).• When the SLEEP instruction is executed in high-speed mode or medium-speed mode, operation shifts to sleep mode, watch mode^{*1 *2}, or subactive mode^{*1 *2}.• When the SLEEP instruction is executed in subactive mode^{*2}, operation shifts to subsleep mode^{*2}, watch mode^{*2}, or high-speed mode.

- Notes:
1. Always set high-speed mode when shifting to watch mode or subactive mode.
 2. Bit 4 (PSS) in TCSR of WDT1 is valid in the U-mask and W-mask versions, and H8S/2635 Group. In versions other than the U-mask and W-mask versions, and H8S/2635 Group, however, the PSS bit must always be written with 0 since no subclock functions are available.

23B.2.5 Module Stop Control Register (MSTPCR)

MSTPCRA

Bit	:	7	6	5	4	3	2	1	0
		MSTPA7	MSTPA6	MSTPA5	MSTPA4	MSTPA3	MSTPA2	MSTPA1	MSTPA0
Initial value :		0	0	1	1	1	1	1	1
R/W	:	R/W	R/W	R/W	R/W	R/W	R/W	R/W	R/W

MSTPCRB

Bit	:	7	6	5	4	3	2	1	0
		MSTPB7	MSTPB6	MSTPB5	MSTPB4	MSTPB3	MSTPB2	MSTPB1	MSTPB0
Initial value :		1	1	1	1	1	1	1	1
R/W	:	R/W	R/W	R/W	R/W	R/W	R/W	R/W	R/W

MSTPCRC

Bit	:	7	6	5	4	3	2	1	0
		MSTPC7	MSTPC6	MSTPC5	MSTPC4	MSTPC3	MSTPC2	MSTPC1	MSTPC0
Initial value :		1	1	1	1	1	1	1	1
R/W	:	R/W	R/W	R/W	R/W	R/W	R/W	R/W	R/W

MSTPCRD

Bit	:	7	6	5	4	3	2	1	0
		MSTPD7	MSTPD6	MSTPD5	MSTPD4	MSTPD3	MSTPD2	MSTPD1	MSTPD0
Initial value :		1	1	Undefined	Undefined	Undefined	Undefined	Undefined	Undefined
R/W	:	R/W	R/W	—	—	—	—	—	—

MSTPCR, comprising four 8-bit readable/writable registers, performs module stop mode control.

MSTPCRA to MSTPCRC are initialized to H'3FFFFFF by a reset and in hardware standby mode. MSTPCRD is initialized to B'11***** by a reset and in hardware standby mode. They are not initialized in software standby mode.

MSTPCRA/MSTPCRB/MSTPCRC Bits 7 to 0, MSTPCRD Bits 7 and 6—Module Stop (MSTPA7 to MSTPA0, MSTPB7 to MSTPB0, MSTPC7 to MSTPC0, MSTPD7 and MSTPD6): These bits specify module stop mode. See table 23B-5 for the method of selecting the on-chip peripheral functions.

**MSTPCRA/MSTPCRB/
MSTPCRC Bits 7 to 0,
MSTPCRD Bits 7 and 6**

**MSTPA7 to MSTPA0,
MSTPB7 to MSTPB0,
MSTPC7 to MSTPC0,
MSTPD7 and MSTPD6** Description

0	Module stop mode is cleared (initial value of MSTPA7 and MSTPA6)
1	Module stop mode is set (initial value of MSTPA5–0, MSTPB7–0, MSTPC7–0, and MSTPC7, 6)

23B.3 Medium-Speed Mode

In high-speed mode, when the SCK2 to SCK0 bits in SCKCR are set to 1, the operating mode changes to medium-speed mode as soon as the current bus cycle ends. In medium-speed mode, the CPU operates on the operating clock ($\phi/2$, $\phi/4$, $\phi/8$, $\phi/16$, or $\phi/32$) specified by the SCK2 to SCK0 bits. The bus masters other than the CPU (DTC) also operate in medium-speed mode. On-chip supporting modules other than the bus masters always operate on the high-speed clock (ϕ).

In medium-speed mode, a bus access is executed in the specified number of states with respect to the bus master operating clock. For example, if $\phi/4$ is selected as the operating clock, on-chip memory is accessed in 4 states, and internal I/O registers in 8 states.

Medium-speed mode is cleared by clearing all of bits SCK2 to SCK0 to 0. A transition is made to high-speed mode and medium-speed mode is cleared at the end of the current bus cycle.

If a SLEEP instruction is executed when the SSBY bit in SBYCR is cleared to 0, and LSON bit in LPWRCR is cleared to 0, a transition is made to sleep mode. When sleep mode is cleared by an interrupt, medium-speed mode is restored.

When the SLEEP instruction is executed with the SSBY bit = 1, LPWRCR LSON bit = 0, and TCSR (WDT1) PSS bit = 0, operation shifts to the software standby mode. When software standby mode is cleared by an external interrupt, medium-speed mode is restored.

When the $\overline{\text{RES}}$ pin is set low and medium-speed mode is cancelled, operation shifts to the reset state. The same applies in the case of a reset caused by overflow of the watchdog timer.

When the $\overline{\text{STBY}}$ pin is driven low, a transition is made to hardware standby mode.

Figure 23B-2 shows the timing for transition to and clearance of medium-speed mode.

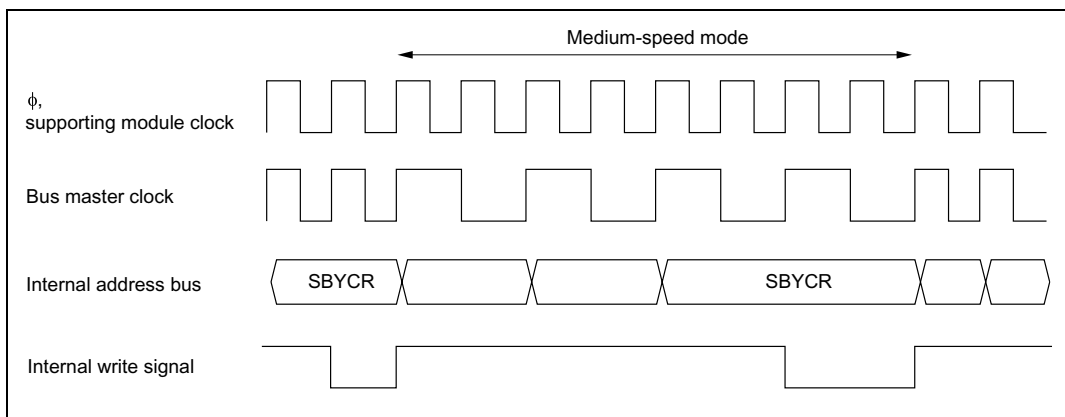

Figure 23B-2 Medium-Speed Mode Transition and Clearance Timing

23B.4 Sleep Mode

23B.4.1 Sleep Mode

When the SLEEP instruction is executed when the SBYCR SSBY bit = 0 and the LPWRCR LSON bit = 0, the CPU enters the sleep mode. In sleep mode, CPU operation stops but the contents of the CPU's internal registers are retained. Other supporting modules do not stop.

23B.4.2 Exiting Sleep Mode

Sleep mode is exited by any interrupt, or signals at the $\overline{\text{RES}}$, or $\overline{\text{STBY}}$ pins.

Exiting Sleep Mode by Interrupts: When an interrupt occurs, sleep mode is exited and interrupt exception processing starts. Sleep mode is not exited if the interrupt is disabled, or interrupts other than NMI are masked by the CPU.

Exiting Sleep Mode by $\overline{\text{RES}}$ pin: Setting the $\overline{\text{RES}}$ pin level Low selects the reset state. After the stipulated reset input duration, driving the $\overline{\text{RES}}$ pin High starts the CPU performing reset exception processing.

Exiting Sleep Mode by $\overline{\text{STBY}}$ Pin: When the $\overline{\text{STBY}}$ pin level is driven Low, a transition is made to hardware standby mode.

23B.5 Module Stop Mode

23B.5.1 Module Stop Mode

Module stop mode can be set for individual on-chip supporting modules.

When the corresponding MSTP bit in MSTPCR is set to 1, module operation stops at the end of the bus cycle and a transition is made to module stop mode. The CPU continues operating independently.

Table 23B-5 shows MSTP bits and the corresponding on-chip supporting modules.

When the corresponding MSTP bit is cleared to 0, module stop mode is cleared and the module starts operating at the end of the bus cycle. In module stop mode, the internal states of modules other than the SCI, Motor control PWM, A/D converter and HCAN are retained.

After reset clearance, all modules other than DTC are in module stop mode.

When an on-chip supporting module is in module stop mode, read/write access to its registers is disabled.

Table 23B-5 MSTP Bits and Corresponding On-Chip Supporting Modules

Register	Bit	Module
MSTPCRA	MSTPA6	Data transfer controller (DTC)* ³
	MSTPA5	16-bit timer pulse unit (TPU)
	MSTPA3	Programmable pulse generator (PPG)* ³
	MSTPA2	D/A converter (channel 0, 1)* ³
	MSTPA1	A/D converter
	MSTPA0* ¹	
MSTPCRB	MSTPB7	Serial communication interface 0 (SCI0)
	MSTPB6	Serial communication interface 1 (SCI1)
	MSTPB5	Serial communication interface 2 (SCI2)
	MSTPB4	I ² C bus interface 0 (IIC0)* ²
	MSTPB3	I ² C bus interface 1 (IIC1)* ²
	MSTPB0* ¹	
MSTPCRC	MSTPC4	PC break controller (PBC)* ³
	MSTPC3	HCAN0
	MSTPC2	HCAN1* ³
	MSTPC1* ¹	
	MSTPC0* ¹	
MSTPCRD	MSTPD7	Motor control PWM (PWM)
	MSTPD6* ¹	

- Notes: 1. MSTPA0, MSTPB0 and MSTPC1 to MSTPC0 and MSTPD6 are readable/writable bits with an initial value of 1.
2. The I²C bus interface is available as an option in the H8S/2638, H8S/2639, and H8S/2630. The product equipped with the I²C bus interface is the W-mask version. When this optional feature is not used or in H8S/2636, MSTB4 and MSTB3 are readable and writable bits that have 1 as their initial value.
3. The DTC, PPG, D/A converter, PBC, and HCAN1 are not implemented in the H8S/2635 and H8S/2634. MSTPA6, MSTPA3, MSTPA2, MSTPC4, and MSTPC2 are readable/writable bits, but only 1 should be written to them.

23B.5.2 Usage Notes

Note: The DTC is not implemented in the H8S/2635 Group.

DTC Module Stop: Depending on the operating status of the DTC, the MSTPA7 and MSTPA6 bits may not be set to 1. Setting of the DTC module stop mode should be carried out only when the respective module is not activated.

For details, refer to section 8, Data Transfer Controller (DTC).

On-Chip Supporting Module Interrupt: Relevant interrupt operations cannot be performed in module stop mode. Consequently, if module stop mode is entered when an interrupt has been requested, it will not be possible to clear the CPU interrupt source or the DTC activation source. Interrupts should therefore be disabled before entering module stop mode.

Writing to MSTPCR: MSTPCR should only be written to by the CPU.

23B.6 Software Standby Mode

23B.6.1 Software Standby Mode

A transition is made to software standby mode when the SLEEP instruction is executed when the SBYCR SSBY bit = 1 and the LPWRCR LSON bit = 0, and the TCSR (WDT1) PSS bit = 0. In this mode, the CPU, on-chip supporting modules, and oscillator all stop*. However, the contents of the CPU's internal registers, RAM data, and the states of on-chip supporting modules other than the SCI, A/D converter, Motor control PWM, HCAN and I/O ports, are retained. Whether the address bus and bus control signals are placed in the high-impedance state.

In this mode the oscillator stops*, and therefore power dissipation is significantly reduced.

Note: * The subclock (ϕ SUB) operates if the SUBSTP bit in LPWRCR is set to 0.

23B.6.2 Clearing Software Standby Mode

Software standby mode is cleared by an external interrupt (NMI pin, or pins $\overline{\text{IRQ0}}$ to $\overline{\text{IRQ5}}$), or by means of the $\overline{\text{RES}}$ pin or $\overline{\text{STBY}}$ pin.

- Clearing with an interrupt

When an NMI or IRQ0 to IRQ5 interrupt request signal is input, clock oscillation starts, and after the elapse of the time set in bits STS2 to STS0 in SYSCR, stable clocks are supplied to the entire chip, software standby mode is cleared, and interrupt exception handling is started.

When clearing software standby mode with an IRQ0 to IRQ5 interrupt, set the corresponding enable bit to 1 and ensure that no interrupt with a higher priority than interrupts IRQ0 to IRQ5 is generated. Software standby mode cannot be cleared if the interrupt has been masked on the CPU side or has been designated as a DTC activation source.

- Clearing with the $\overline{\text{RES}}$ pin

When the $\overline{\text{RES}}$ pin is driven Low, clock oscillation is started. At the same time as clock oscillation starts, clocks are supplied to the entire chip. Note that the $\overline{\text{RES}}$ pin must be held Low until clock oscillation stabilizes. When the $\overline{\text{RES}}$ pin goes high, the CPU begins reset exception handling.

- Clearing with the $\overline{\text{STBY}}$ pin

When the $\overline{\text{STBY}}$ pin is driven Low, a transition is made to hardware standby mode.

23B.6.3 Setting Oscillation Stabilization Time after Clearing Software Standby Mode

Bits STS2 to STS0 in SBYCR should be set as described below.

Using a Crystal Oscillator:

1. Setting for H8S/2636, H8S/2638, H8S/2639, H8S/2630

Set bits STS2 to STS0 so that the standby time is at least 8 ms (the oscillation stabilization time).

Table 23B-6 shows the standby times for different operating frequencies and settings of bits STS2 to STS0.

Table 23B-6 Oscillation Stabilization Time Settings

STS2	STS1	STS0	Standby Time	20	16	12	10	8	6	5	4	Unit
				MHz	MHz	MHz	MHz	MHz	MHz	MHz		
0	0	0	8192 states	0.41	0.51	0.68	0.8	1.0	1.3	1.6	2.0	ms
		1	16384 states	0.82	1.0	1.3	1.6	2.0	2.7	3.2	4.1	
	1	0	32768 states	1.6	2.0	2.7	3.3	4.1	5.5	6.5	8.2	
		1	65536 states	3.3	4.1	5.5	6.6	8.2	10.9	13.1	16.4	
1	0	0	131072 states	6.6	8.2	10.9	13.1	16.4	21.8	26.2	32.8	
		1	262144 states	13.1	16.4	21.8	26.2	32.8	43.6	52.4	65.6	
	1	0	Reserved	—	—	—	—	—	—	—	—	μs
		1	16 states (Setting prohibited)	0.8	1.0	1.3	1.6	2.0	2.6	3.2	4.0	

: Recommended time setting

2. Setting for H8S/2635, H8S/2634

Set bits STS2 to STS0 so that the standby time is at least 12 ms (the oscillation stabilization time).

Table 23B-7 shows the standby times for different operating frequencies and settings of bits STS2 to STS0.

Table 23B-7 Oscillation Stabilization Time Settings

STS2	STS1	STS0	Standby Time	20 MHz	16 MHz	10 MHz	8 MHz	5 MHz	4 MHz	Unit
0	0	0	8192 states	0.41	0.51	0.8	1.0	1.6	2.0	ms
		1	16384 states	0.82	1.0	1.6	2.0	3.2	4.1	
	1	0	32768 states	1.6	2.0	3.3	4.1	6.5	8.2	
		1	65536 states	3.3	4.1	6.6	8.2	13.1	16.4	
1	0	0	131072 states	6.6	8.2	13.1	16.4	26.2	32.8	
		1	262144 states	13.1	16.4	26.2	32.8	52.4	65.6	
	1	0	Reserved	—	—	—	—	—	—	μs
		1	16 states (Setting prohibited)	0.8	1.0	1.6	2.0	3.2	4.0	

: Recommended time setting

Using an External Clock: The PLL circuit requires time to stabilize, so the standby time should be set to a value of 2 ms or more.

23B.6.4 Software Standby Mode Application Example

Figure 23B-3 shows an example in which a transition is made to software standby mode at the falling edge on the NMI pin, and software standby mode is cleared at the rising edge on the NMI pin.

In this example, an NMI interrupt is accepted with the NMIEG bit in SYSCR cleared to 0 (falling edge specification), then the NMIEG bit is set to 1 (rising edge specification), the SSBY bit is set to 1, and a SLEEP instruction is executed, causing a transition to software standby mode.

Software standby mode is then cleared at the rising edge on the NMI pin.

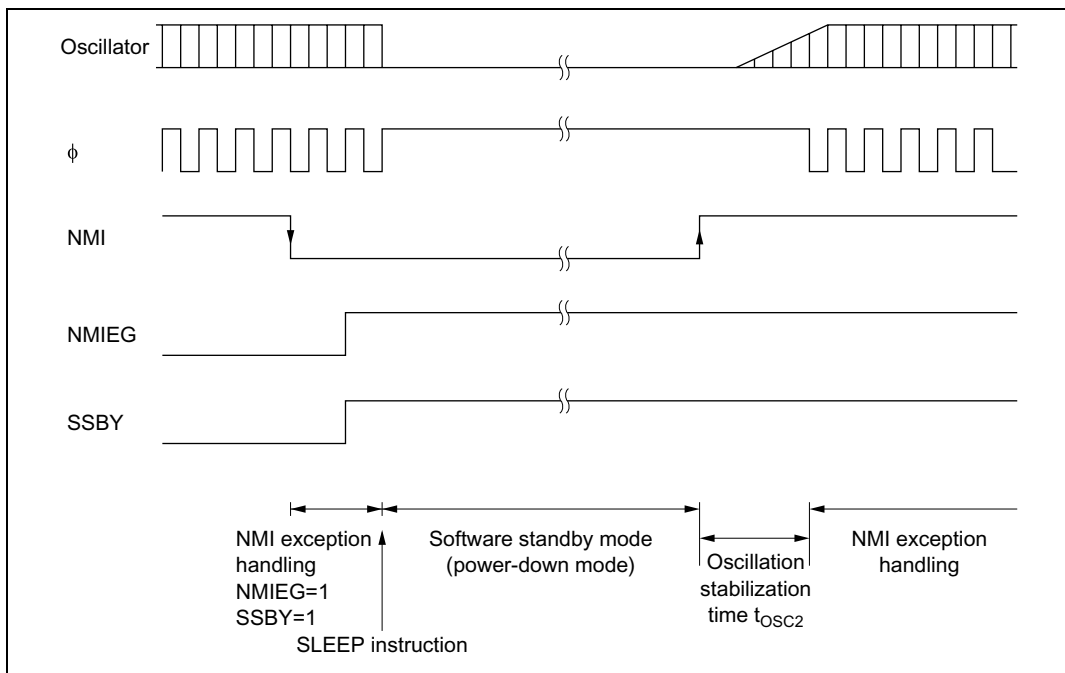

Figure 23B-3 Software Standby Mode Application Example

23B.6.5 Usage Notes

I/O Port Status: In software standby mode, I/O port states are retained. If the OPE bit is set to 1, the address bus and bus control signal output is also retained. Therefore, there is no reduction in current dissipation for the output current when a high-level signal is output.

Current Dissipation during Oscillation Stabilization Wait Period: Current dissipation increases during the oscillation stabilization wait period.

Write Data Buffer Function: The write data buffer function and software standby mode cannot be used at the same time. When the write data buffer function is used, the WDBE bit in BCRL should be cleared to 0 to cancel the write data buffer function before entering software standby mode. Also check that external writes have finished, by reading external addresses, etc., before executing a SLEEP instruction to enter software standby mode. See section 7.9, Write Data Buffer Function, for details of the write data buffer function.

23B.7 Hardware Standby Mode

23B.7.1 Hardware Standby Mode

When the $\overline{\text{STBY}}$ pin is driven low, a transition is made to hardware standby mode from any mode.

In hardware standby mode, all functions enter the reset state and stop operation, resulting in a significant reduction in power dissipation. As long as the prescribed voltage is supplied, on-chip RAM data is retained. I/O ports are set to the high-impedance state.

In order to retain on-chip RAM data, the RAME bit in SYSCR should be cleared to 0 before driving the $\overline{\text{STBY}}$ pin low.

Do not change the state of the mode pins (MD2 to MD0) while the chip is in hardware standby mode.

Hardware standby mode is cleared by means of the $\overline{\text{STBY}}$ pin and the $\overline{\text{RES}}$ pin. When the $\overline{\text{STBY}}$ pin is driven high while the $\overline{\text{RES}}$ pin is low, the reset state is set and clock oscillation is started. Ensure that the $\overline{\text{RES}}$ pin is held low until the clock oscillator stabilizes (at least 8 ms—the oscillation stabilization time—when using a crystal oscillator). When the $\overline{\text{RES}}$ pin is subsequently driven high, a transition is made to the program execution state via the reset exception handling state.

23B.7.2 Hardware Standby Mode Timing

Figure 23B-4 shows an example of hardware standby mode timing.

When the $\overline{\text{STBY}}$ pin is driven low after the $\overline{\text{RES}}$ pin has been driven low, a transition is made to hardware standby mode. Hardware standby mode is cleared by driving the $\overline{\text{STBY}}$ pin high, waiting for the oscillation stabilization time, then changing the $\overline{\text{RES}}$ pin from low to high.

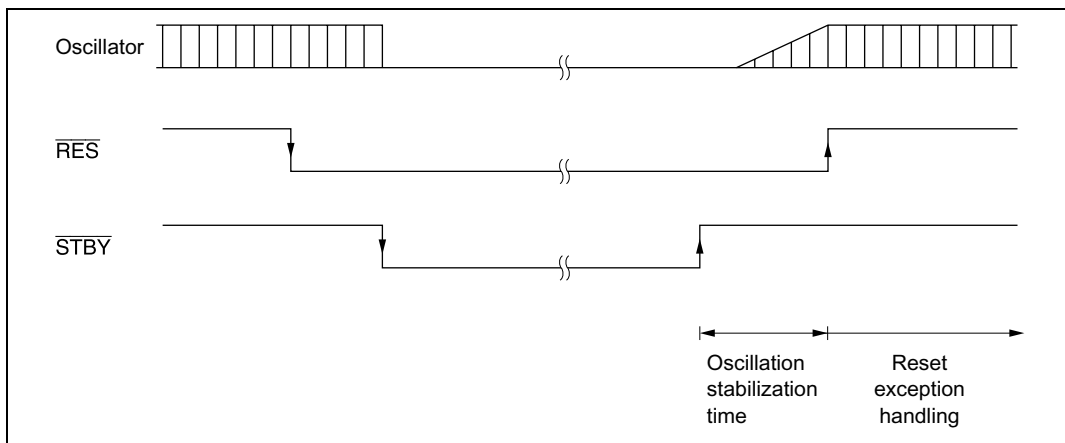

Figure 23B-4 Hardware Standby Mode Timing

23B.8 Watch Mode (U-Mask, W-Mask Version, H8S/2635 Group Only)

23B.8.1 Watch Mode

CPU operation makes a transition to watch mode when the SLEEP instruction is executed in high-speed mode or subactive mode with SBYCR SSBY=1, LPWRCR DTON = 0, and TCSR (WDT1) PSS = 1.

In watch mode, the CPU is stopped and supporting modules other than WDT1 are also stopped. The contents of the CPU's internal registers, the data in internal RAM, and the statuses of the internal supporting modules (excluding the SCI, ADC, HCAN, and Motor control PWM) and I/O ports are retained.

23B.8.2 Exiting Watch Mode

Watch mode is exited by any interrupt (WOVI interrupt, NMI pin, or $\overline{\text{IRQ0}}$ to $\overline{\text{IRQ5}}$), or signals at the $\overline{\text{RES}}$, or $\overline{\text{STBY}}$ pins.

(1) Exiting Watch Mode by Interrupts

When an interrupt occurs, watch mode is exited and a transition is made to high-speed mode or medium-speed mode when the LPWRCR LSON bit = 0 or to subactive mode when the LSON bit = 1. When a transition is made to high-speed mode, a stable clock is supplied to all LSI circuits and interrupt exception processing starts after the time set in SBYCR STS2 to STS0 has elapsed. In the case of IRQ0 to IRQ5 interrupts, no transition is made from watch mode if the corresponding enable bit has been cleared to 0, and, in the case of interrupts from the internal supporting modules, the interrupt enable register has been set to disable the reception of that interrupt, or is masked by the CPU.

See section 23B.6.3, Setting Oscillation Stabilization Time after Clearing Software Standby Mode for how to set the oscillation stabilization time when making a transition from watch mode to high-speed mode.

(2) Exiting Watch Mode by $\overline{\text{RES}}$ pins

For exiting watch mode by the $\overline{\text{RES}}$ pins, see, Clearing with the $\overline{\text{RES}}$ pins in section 23B.6.2, Clearing Software Standby Mode.

(3) Exiting Watch Mode by $\overline{\text{STBY}}$ pin

When the $\overline{\text{STBY}}$ pin level is driven Low, a transition is made to hardware standby mode.

23B.8.3 Notes

(1) I/O Port Status

The status of the I/O ports is retained in watch mode. Also, when the OPE bit is set to 1, the address bus and bus control signals continue to be output. Therefore, when a High level is output, the current consumption is not diminished by the amount of current to support the High level output.

(2) Current Consumption when Waiting for Oscillation Stabilization

The current consumption increases during stabilization of oscillation.

23B.9 Subsleep Mode (U-Mask, W-Mask Version, H8S/2635 Group Only)

23B.9.1 Subsleep Mode

When the SLEEP instruction is executed with the SBYCR SSBY bit = 0, LPWRCR LSON bit = 1, and TCSR (WDT1) PSS bit = 1, CPU operation shifts to subsleep mode.

In subsleep mode, the CPU is stopped. Supporting modules other than WDT0, and WDT1 are also stopped. The contents of the CPU's internal registers, the data in internal RAM, and the statuses of the internal supporting modules (excluding the SCI, ADC, HCAN, and Motor control PWM) and I/O ports are retained.

23B.9.2 Exiting Subsleep Mode

Subsleep mode is exited by an interrupt (interrupts from internal supporting modules, NMI pin, or $\overline{\text{IRQ0}}$ to $\overline{\text{IRQ5}}$), or signals at the $\overline{\text{RES}}$ or $\overline{\text{STBY}}$ pins.

(1) Exiting Subsleep Mode by Interrupts

When an interrupt occurs, subsleep mode is exited and interrupt exception processing starts.

In the case of IRQ0 to IRQ5 interrupts, subsleep mode is not cancelled if the corresponding enable bit has been cleared to 0, and, in the case of interrupts from the internal supporting modules, the interrupt enable register has been set to disable the reception of that interrupt, or is masked by the CPU.

(2) Exiting Subsleep Mode by $\overline{\text{RES}}$

For exiting subsleep mode by the $\overline{\text{RES}}$ pins, see, Clearing with the $\overline{\text{RES}}$ pins in section 23B.6.2, Clearing Software Standby Mode.

(3) Exiting Subsleep Mode by $\overline{\text{STBY}}$ Pin

When the $\overline{\text{STBY}}$ pin level is driven Low, a transition is made to hardware standby mode.

23B.10 Subactive Mode (U-Mask, W-Mask Version, H8S/2635 Group Only)

23B.10.1 Subactive Mode

When the SLEEP instruction is executed in high-speed mode with the SBYCR SSBY bit = 1, LPWRCR DTON bit = 1, LSON bit = 1, and TCSR (WDT1) PSS bit = 1, CPU operation shifts to subactive mode. When an interrupt occurs in watch mode, and if the LSON bit of LPWRCR is 1, a transition is made to subactive mode. And if an interrupt occurs in subsleep mode, a transition is made to subactive mode.

In subactive mode, the CPU operates at low speed on the subclock, and the program is executed step by step. Supporting modules other than WDT0, and WDT1 are also stopped.

When operating the CPU in subactive mode, the SCKCR SCK2 to SCK0 bits must be set to 0.

23B.10.2 Exiting Subactive Mode

Subactive mode is exited by the SLEEP instruction or the $\overline{\text{RES}}$ or $\overline{\text{STBY}}$ pins.

(1) Exiting Subactive Mode by SLEEP Instruction

When the SLEEP instruction is executed with the SBYCR SSBY bit = 1, LPWRCR DTON bit = 0, and TCSR (WDT1) PSS bit = 1, the CPU exits subactive mode and a transition is made to watch mode. When the SLEEP instruction is executed with the SBYCR SSBY bit = 0, LPWRCR LSON bit = 1, and TCSR (WDT1) PSS bit = 1, a transition is made to subsleep mode. Finally, when the SLEEP instruction is executed with the SBYCR SSBY bit = 1, LPWRCR DTON bit = 1, LSON bit = 0, and TCSR (WDT1) PSS bit = 1, a direct transition is made to high-speed mode (SCK0 to SCK2 all 0).

See section 23B.11, Direct Transitions for details of direct transitions.

(2) Exiting Subactive Mode by $\overline{\text{RES}}$ Pins

For exiting subactive mode by the $\overline{\text{RES}}$ pins, see, Clearing with the $\overline{\text{RES}}$ pins in section 23B.6.2, Clearing Software Standby Mode.

(3) Exiting Subactive Mode by $\overline{\text{STBY}}$ Pin

When the $\overline{\text{STBY}}$ pin level is driven Low, a transition is made to hardware standby mode.

23B.11 Direct Transitions (U-Mask, W-Mask Version, H8S/2635 Group Only)

23B.11.1 Overview of Direct Transitions

There are three modes, high-speed, medium-speed, and subactive, in which the CPU executes programs. When a direct transition is made, there is no interruption of program execution when shifting between high-speed and subactive modes. Direct transitions are enabled by setting the LPWRCR DTON bit to 1, then executing the SLEEP instruction. After a transition, direct transition interrupt exception processing starts.

(1) Direct Transitions from High-Speed Mode to Subactive Mode

Execute the SLEEP instruction in high-speed mode when the SBYCR SSBY bit = 1, LPWRCR LSON bit = 1, and DTON bit = 1, and TSCR (WDT1) PSS bit = 1 to make a transition to subactive mode.

(2) Direct Transitions from Subactive Mode to High-Speed Mode

Execute the SLEEP instruction in subactive mode when the SBYCR SSBY bit = 1, LPWRCR LSON bit = 0, and DTON bit = 1, and TSCR (WDT1) PSS bit = 1 to make a direct transition to high-speed mode after the time set in SBYCR STS2 to STS0 has elapsed.

23B.12 ϕ Clock Output Disabling Function

Output of the ϕ clock can be controlled by means of the PSTOP bit in SCKCR, and DDR for the corresponding port. When the PSTOP bit is set to 1, the ϕ clock stops at the end of the bus cycle, and ϕ output goes high. ϕ clock output is enabled when the PSTOP bit is cleared to 0. When DDR for the corresponding port is cleared to 0, ϕ clock output is disabled and input port mode is set. Table 23B-8 shows the state of the ϕ pin in each processing state.

Using the on-chip PLL circuit to lower the oscillator frequency or prohibiting external ϕ clock output also have the effect of reducing unwanted electromagnetic interference*. Therefore, consideration should be given to these options when deciding on system board settings.

Note: * Electromagnetic interference: EMI (Electro Magnetic Interference)

Table 23B-8 ϕ Pin State in Each Processing State

DDR	0	1	1
PSTOP	—	0	1
Hardware standby mode	High impedance	High impedance	High impedance
Software standby mode, watch mode*, and direct transition	High impedance	Fixed high	Fixed high
Sleep mode and subsleep mode*	High impedance	ϕ output	Fixed high
High-speed mode, medium-speed mode, and subactive mode*	High impedance	ϕ output	Fixed high
Subactive mode	High impedance	ϕ_{SUB} output	Fixed high

Note: * Subclock functions (subactive mode, subsleep mode, and watch mode) are available in the U-mask and W-mask versions, and H8S/2635 Group only. These functions cannot be used with the other versions.

23B.13 Usage Notes

1. When making a transition to subactive mode or watch mode, set the DTC to enter module stop mode (write 1 to the relevant bits in MSTPCR), and then read the relevant bits to confirm that they are set to 1 before mode transition. Do not clear module stop mode (write 0 to the relevant bits in MSTPCR) until a transition from subactive mode to high-speed mode or medium-speed mode has been performed.

If a DTC activation source occurs in subactive mode, the DTC will be activated only after module stop mode has been cleared and high-speed mode or medium-speed mode has been entered.

2. The on-chip peripheral modules (DTC and TPU) which halt operation in subactive mode cannot clear an interrupt in subactive mode. Therefore, if a transition is made to subactive mode while an interrupt is requested, the CPU interrupt source cannot be cleared. Disable the interrupts of each on-chip peripheral module before executing a SLEEP instruction to enter subactive mode or watch mode.
3. A 1 is always returned when an attempt is made to read the pin status of I/O ports 1, 4, 9, or F during operation in subactive mode. (In the case of port 1, pins 13 to 10 are readable.) In addition, the ports may be used as output ports (except for ports 4 and 9). The procedure for determining the pin status during operation in subactive mode is as follows.
 - [1] Use ports 3, A, B, C, D, E, H, and J as input ports.
 - [2] Use external interrupt inputs (IRQ0 to IRQ5). (If the level sense setting has been selected for the IRQ pins, an interrupt request is generated by a low-level input.)
4. Operation cannot be guaranteed if a transition is made to the subactive mode, subsleep mode, or watch mode when the SUBSTP bit in LPWRCR is set to 1 (subclock generation prohibited). To prevent problems, it should be confirmed that the SUBSTP bit has been cleared to 0 before transitioning to the subactive mode, subsleep mode, or watch mode.
5. (H8S/2639 Group, H8S/2635 Group only) The subclock (ϕ SUB) is frequency divided internally, so the clock oscillator does not halt even if a transition to the software standby mode occurs when the SUBSTP bit in LPWRCR is cleared to 0. The SUBSTP bit in LPWRCR should be set to 1 before transitioning to the software standby mode.

Section 24 Electrical Characteristics

24.1 H8S/2636 Group Electrical Characteristics

24.1.1 Absolute Maximum Ratings

Table 24-1 lists the absolute maximum ratings.

Table 24-1 Absolute Maximum Ratings

Item	Symbol	Value	Unit
Power supply voltage	V_{CC}	-0.3 to +7.0	V
Input voltage (OSC1, OSC2)	V_{in}	-0.3 to +4.3	V
Input voltage (XTAL, EXTAL)	V_{in}	-0.3 to $V_{CC} + 0.3$	V
Input voltage (ports 4 and 9)	V_{in}	-0.3 to $AV_{CC} + 0.3$	V
Input voltage (ports H and J)	V_{in}	-0.3 to $PWMV_{CC} + 0.3$	V
Input voltage (except XTAL, EXTAL, OSC1, OSC2, ports 4, 9, H and J)	V_{in}	-0.3 to $V_{CC} + 0.3$	V
Reference voltage	V_{ref}	-0.3 to $AV_{CC} + 0.3$	V
Analog power supply voltage	AV_{CC}	-0.3 to +7.0	V
Analog input voltage	V_{AN}	-0.3 to $AV_{CC} + 0.3$	V
Operating temperature	T_{opr}	Regular specifications: -20 to +75	°C
		Wide-range specifications: -40 to +85	°C
Storage temperature	T_{stg}	-55 to +125	°C

Caution: Permanent damage to the chip may result if absolute maximum rating are exceeded.

24.1.2 Power Supply Voltage and Operating Frequency Range

Power supply voltage and operating frequency ranges (shaded areas) are shown in figure 24-1.

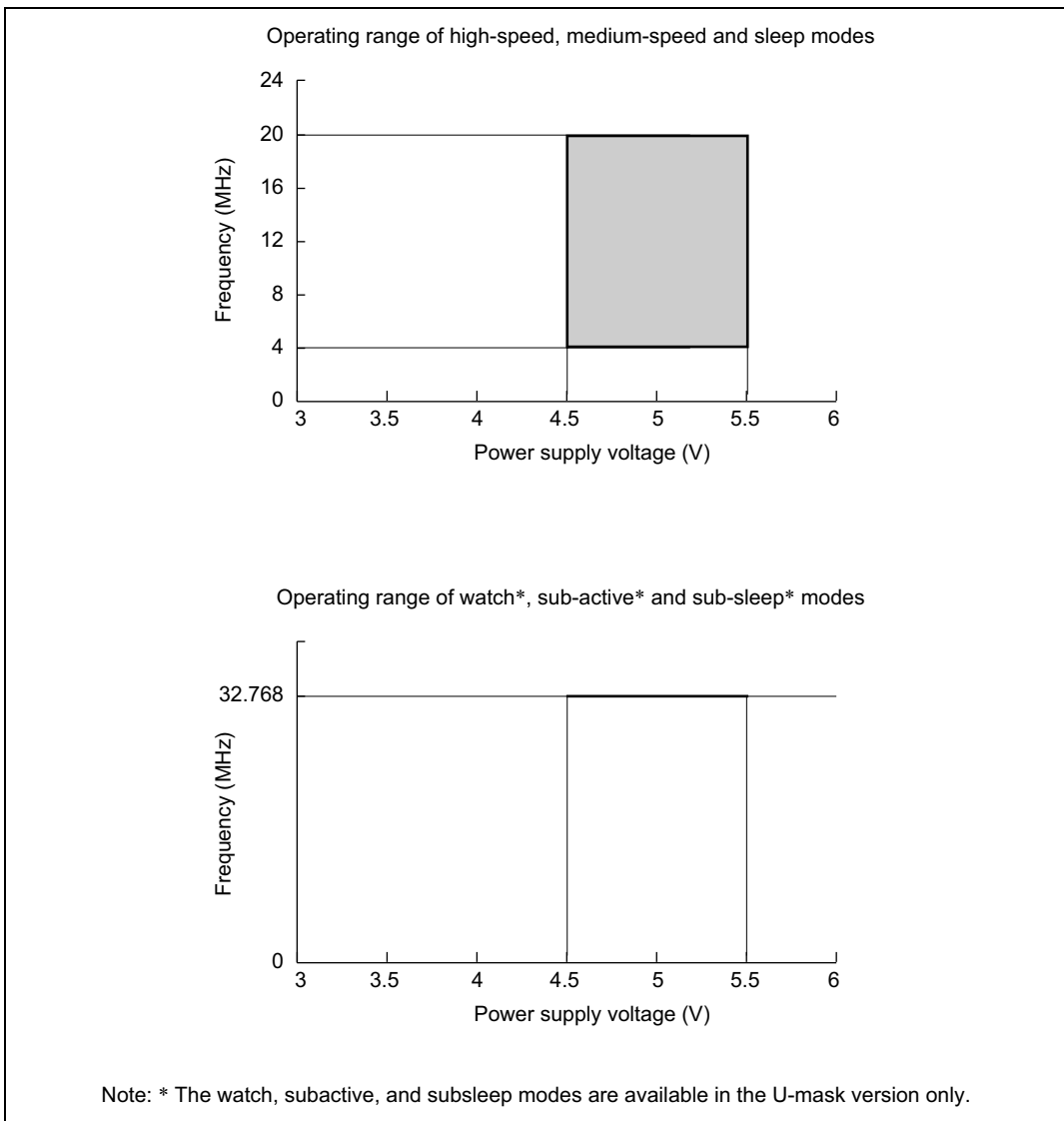

Figure 24-1 Power Supply Voltage and Operating Ranges

24.1.3 DC Characteristics

Table 24-2 lists the DC characteristics. Table 24-3 lists the permissible output currents.

Table 24-2 DC Characteristics

Conditions: $V_{CC} = 4.5\text{ V to }5.5\text{ V}$, $PWMV_{CC} = 4.5\text{ V to }5.5\text{ V}$, $AV_{CC} = 4.5\text{ V to }5.5\text{ V}$,
 $V_{ref} = 4.5\text{ V to }AV_{CC}$, $V_{SS} = PWMV_{SS} = PLLV_{SS} = AV_{SS} = 0\text{ V}$, $T_a = -20^\circ\text{C to }+75^\circ\text{C}$
 (regular specifications), $T_a = -40^\circ\text{C to }+85^\circ\text{C}$ (wide-range specifications)*1*6

Item	Symbol	Min.	Typ.	Max.	Unit	Test Conditions
Schmitt trigger input voltage	IRQ0 to IRQ5 V_T^-	1.0	—	—	V	
	V_T^+	—	—	$V_{CC} \times 0.7$		
	$V_T^+ - V_T^-$	0.4	—	—		
Input high voltage	\overline{RES} , \overline{STBY} , NMI, FWE, MD2 to MD0	V_{IH}	$V_{CC} - 0.7$	—	$V_{CC} + 0.3$	V
	EXTAL		$V_{CC} \times 0.7$	—	$V_{CC} + 0.3$	
	Ports 1, 3, F		2.2	—	$V_{CC} + 0.3$	
	Ports A to E		$V_{CC} \times 0.8$	—	$V_{CC} + 0.3$	
	Ports H, J		$PWMV_{CC} \times 0.8$	—	$PWMV_{CC} + 0.3$	
	HRxD0, HRxD1		2.2	—	$V_{CC} + 0.3$	
	Ports 4 and 9		$AV_{CC} \times 0.7$	—	$AV_{CC} + 0.3$	
Input low voltage	\overline{RES} , \overline{STBY} , NMI, FWE, MD2 to MD0	V_{IL}	-0.3	—	0.5	V
	EXTAL		-0.3	—	0.8	
	Ports 1, 3, F		-0.3	—	0.8	
	Ports A to E		-0.3	—	$V_{CC} \times 0.2$	
	Ports H, J		-0.3	—	$PWMV_{CC} \times 0.2$	
	HRxD0, HRxD1		-0.3	—	$V_{CC} \times 0.2$	
	Ports 4, 9		-0.3	—	$AV_{CC} \times 0.2$	

Item	Symbol	Min.	Typ.	Max.	Unit	Test Conditions	
Output high voltage	Ports 1, 3, A to F, H, J HTxD0, HTxD1	V_{OH}	$V_{CC} - 0.5$	—	—	V	$I_{OH} = -200 \mu A$
			3.5	—	—		$I_{OH} = -1 \text{ mA}$
	PWM1A to PWM1H, PWM2A to PWM2H		$PWMV_{CC} - 0.5$	—	—		$I_{OH} = -15 \text{ mA}$
Output low voltage	All output pins except PWM1A to PWM1H, PWM2A to PWM2H	V_{OL}	—	—	0.4	V	$I_{OL} = 1.6 \text{ mA}$
			—	—	0.5	V	$I_{OL} = 15 \text{ mA}$
Input leakage current	\overline{RES}	$ I_{in} $	—	—	1.0	μA	$V_{in} = 0.5 \text{ V to } V_{CC} - 0.5 \text{ V}$
	\overline{STBY} , \overline{NMI} , MD2 to MD0		—	—	1.0		
	HRxD0, HRxD1, FWE		—	—	1.0		
	Ports 4, 9		—	—	1.0		
Three-state leakage current (off state)	Ports 1, 3, A to F, H, J HTxD0, HTxD1	$ I_{TSI} $	—	—	1.0	μA	$V_{in} = 0.5 \text{ V to } V_{CC} - 0.5 \text{ V}$
MOS input pull-up current	Ports A to E	$-I_P$	50	—	300	μA	$V_{in} = 0 \text{ V}$
Input capacitance	\overline{RES}	C_{in}	—	—	30	pF	$V_{in} = 0 \text{ V}$ $f = 1 \text{ MHz}$ $T_a = 25^\circ C$
	NMI		—	—	30		
	All input pins except \overline{RES} and NMI		—	—	15		

Item		Symbol	Min.	Typ.	Max.	Unit	Test Conditions
Current dissipation*2	Normal operation	I_{CC} *4	—	75	90	mA	$f = 20$ MHz
	Sleep mode		—	65	80		
	All modules stopped		—	57	—	mA	$f = 20$ MHz (reference value)
	Medium-speed mode ($\phi/32$)		—	49	—		
	Subactive mode*5		—	130	220	μ A	Using 32.768 kHz crystal resonator
	Subsleep mode*5		—	80	160		
	Watch mode*5		—	30	60		
	Standby mode*3		—	2.0	5.0	μ A	$T_a \leq 50^\circ\text{C}$
			—	—	20		$50^\circ\text{C} < T_a$
Analog power supply current	During A/D and D/A conversion	I_{CC}	—	1.0	2.0	mA	$AV_{CC} = 5.0$ V
	Idle		—	0.1	5.0	μ A	
Reference current	During A/D and D/A conversion	I_{CC}	—	4.0	5.0	mA	$V_{ref} = 5.0$ V
	Idle		—	0.1	5.0	μ A	
RAM standby voltage		V_{RAM}	2.0	—	—	V	

- Notes: 1. If the A/D and D/A converters are not used, do not leave the AV_{CC} , V_{ref} , and AV_{SS} pins open. Apply a voltage between 4.5 V and 5.5 V to the AV_{CC} and V_{ref} pins by connecting them to V_{CC} , for instance. Set $V_{ref} \leq AV_{CC}$.
2. Current dissipation values are for V_{IH} (min.) = $V_{CC} - 0.5$ V, V_{IL} (max.) = 0.5 V with all output pins unloaded and the on-chip pull-up resistors in the off state.
3. The values are for $V_{RAM} \leq V_{CC} < 3.0$ V, V_{IH} (min.) = $V_{CC} \times 0.9$, and V_{IL} (max.) = 0.3 V.
4. I_{CC} depends on V_{CC} and f as follows:
 I_{CC} (max.) = 30 (mA) + 0.54 (mA/(MHz \times V)) $\times V_{CC} \times f$ (normal operation)
 I_{CC} (max.) = 30 (mA) + 0.45 (mA/(MHz \times V)) $\times V_{CC} \times f$ (sleep mode)
5. The watch, subactive, and subsleep modes are available in the U-mask version only. See section 22A.7, Subclock Oscillator, for the method of fixing pins OSC1 and OSC2.
6. If the motor-control PWM timer is not used, do not leave the $PMWV_{CC}$, or $PMWV_{SS}$ pins open. If the motor-control PWM timer is not used, apply a voltage of between 4.5 and 5.5 V to the $PMWV_{CC}$ pin, for instance, by connecting it to V_{CC} .

Table 24-3 Permissible Output Currents

Conditions: $V_{CC} = 4.5\text{ V to }5.5\text{ V}$, $PWMV_{CC} = 4.5\text{ V to }5.5\text{ V}$, $AV_{CC} = 4.5\text{ V to }5.5\text{ V}$,
 $V_{ref} = 4.5\text{ V to }AV_{CC}$, $V_{SS} = PWMV_{SS} = PLLV_{SS} = AV_{SS} = 0\text{ V}$, $T_a = -20^\circ\text{C to }+75^\circ\text{C}$
 (regular specifications), $T_a = -40^\circ\text{C to }+85^\circ\text{C}$ (wide-range specifications)

Item		Symbol	Min.	Typ.	Max.	Unit	Test condition
Permissible output low current (per pin)	All output pins except PWM1A to PWM1H, PWM2A to PWM2H	I_{OL}	—	—	10	mA	
	PWM1A to PWM1H, PWM2A to PWM2H	I_{OL}	—	—	25	mA	$T_a = 85^\circ\text{C}$
					30		$T_a = 25^\circ\text{C}$
		—	—	40	mA	$T_a = -40^\circ\text{C}$	
Permissible output low current (total)	Total of all output pins excepting PWM1A to PWM1H, and PWM2A to PWM2H	ΣI_{OL}	—	—	80	mA	
	Total of PWM1A to PWM1H, and PWM2A to PWM2H	ΣI_{OL}	—	—	150	mA	$T_a = 85^\circ\text{C}$
					180		$T_a = 25^\circ\text{C}$
		—	—	220	mA	$T_a = -40^\circ\text{C}$	
Permissible output high current (per pin)	All output pins except PWM1A to PWM1H, PWM2A to PWM2H	$-I_{OH}$	—	—	2.0	mA	
	PWM1A to PWM1H, PWM2A to PWM2H	$-I_{OH}$	—	—	25	mA	$T_a = 85^\circ\text{C}$
					30		$T_a = 25^\circ\text{C}$
		—	—	40	mA	$T_a = -40^\circ\text{C}$	
Permissible output high current (total)	Total of all output pins excepting PWM1A to PWM1H, and PWM2A to PWM2H	$\Sigma -I_{OH}$	—	—	40	mA	
	Total of PWM1A to PWM1H, and PWM2A to PWM2H	$\Sigma -I_{OH}$	—	—	150	mA	$T_a = 85^\circ\text{C}$
					180		$T_a = 25^\circ\text{C}$
		—	—	220	mA	$T_a = -40^\circ\text{C}$	

Note: To protect chip reliability, do not exceed the output current values in table 24-3.

24.1.4 AC Characteristics

Figure 24-2 show, the test conditions for the AC characteristics.

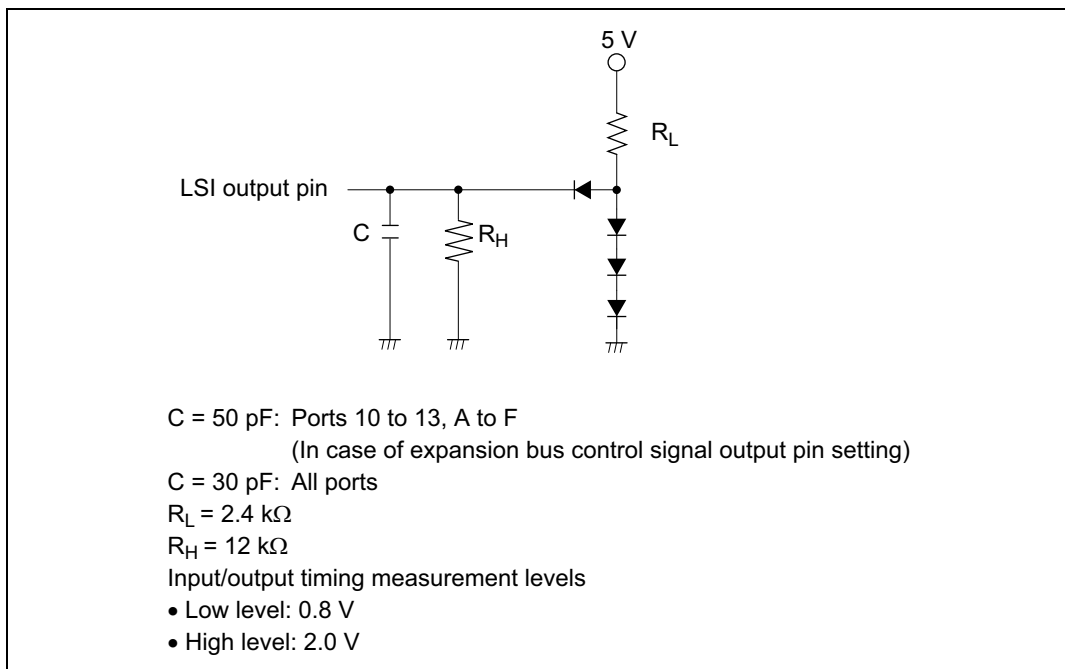

Figure 24-2 Output Load Circuit

(1) Clock Timing

Table 24-4 lists the clock timing

Table 24-4 Clock Timing

Conditions: $V_{CC} = 4.5\text{ V to }5.5\text{ V}$, $PWMV_{CC} = 4.5\text{ V to }5.5\text{ V}$, $AV_{CC} = 4.5\text{ V to }5.5\text{ V}$,
 $V_{ref} = 4.5\text{ V to }AV_{CC}$, $V_{SS} = PWMV_{SS} = PLLV_{SS} = AV_{SS} = 0\text{ V}$,
 $T_a = -20^\circ\text{C to }+75^\circ\text{C}$ (regular specifications), $T_a = -40^\circ\text{C to }+85^\circ\text{C}$ (wide-range specifications)

Item	Symbol	Condition		Unit	Test Conditions
		20MHz			
		Min.	Max.		
Clock cycle time	t_{cyc}	50	250	ns	Figure 24-9
Clock high pulse width	t_{CH}	15	—	ns	
Clock low pulse width	t_{CL}	15	—	ns	
Clock rise time	t_{Cr}	—	10	ns	
Clock fall time	t_{Cf}	—	10	ns	
Clock oscillator settling time at reset (crystal)	t_{OSC1}	20	—	ms	Figure 24-10
Clock oscillator settling time in software standby (crystal)	t_{OSC2}	8	—	ms	Figure 23A-3 Figure 23B-3
External clock output stabilization delay time	t_{DEXT}	2	—	ms	Figure 24-10
32-kHz clock oscillation settling time	t_{OSC3}	—	2	s	
Subclock oscillator frequency	f_{SUB}	32.768		kHz	
Subclock (ϕ_{SUB}) cycle time	t_{SUB}	30.5		μs	

(2) Control Signal Timing

Table 24-5 lists the control signal timing.

Table 24-5 Control Signal Timing

Conditions: $V_{CC} = 4.5\text{ V to }5.5\text{ V}$, $PWMV_{CC} = 4.5\text{ V to }5.5\text{ V}$, $AV_{CC} = 4.5\text{ V to }5.5\text{ V}$,
 $V_{ref} = 4.5\text{ V to }AV_{CC}$, $V_{SS} = PWMV_{SS} = PLLV_{SS} = AV_{SS} = 0\text{ V}$,
 $T_a = -20^\circ\text{C to }+75^\circ\text{C}$ (regular specifications), $T_a = -40^\circ\text{C to }+85^\circ\text{C}$ (wide-range specifications)

Item	Symbol	Condition		Unit	Test Conditions
		Min.	Max.		
$\overline{\text{RES}}$ setup time	t_{RESS}	200	—	ns	Figure 24-11
$\overline{\text{RES}}$ pulse width	t_{RESW}	20	—	t_{cyc}	
NMI setup time	t_{NMIS}	150	—	ns	Figure 24-12
NMI hold time	t_{NMIH}	10	—		
NMI pulse width (exiting software standby mode)	t_{NMW}	200	—	ns	
$\overline{\text{IRQ}}$ setup time	t_{IRQS}	150	—	ns	
$\overline{\text{IRQ}}$ hold time	t_{IRQH}	10	—	ns	
$\overline{\text{IRQ}}$ pulse width (exiting software standby mode)	t_{IRQW}	200	—	ns	

(3) Bus Timing

Table 24-6 lists the bus timing.

Table 24-6 Bus Timing

Conditions: $V_{CC} = 4.5\text{ V to }5.5\text{ V}$, $PWMV_{CC} = 4.5\text{ V to }5.5\text{ V}$, $AV_{CC} = 4.5\text{ V to }5.5\text{ V}$,
 $V_{ref} = 4.5\text{ V to }AV_{CC}$, $V_{SS} = PWMV_{SS} = PLLV_{SS} = AV_{SS} = 0\text{ V}$,
 $T_a = -20^\circ\text{C to }+75^\circ\text{C}$ (regular specifications), $T_a = -40^\circ\text{C to }+85^\circ\text{C}$ (wide-range specifications)

Item	Symbol	Condition		Unit	Test Conditions
		Min.	Max.		
Address delay time	t_{AD}	—	35	ns	Figure 24-13 to Figure 24-17
Address setup time	t_{AS}	$0.5 \times t_{cyc} - 20$	—	ns	
Address hold time	t_{AH}	$0.5 \times t_{cyc} - 15$	—	ns	
\overline{AS} delay time	t_{ASD}	—	20	ns	
\overline{RD} delay time 1	t_{RSD1}	—	20	ns	
\overline{RD} delay time 2	t_{RSD2}	—	20	ns	
Read data setup time	t_{RDS}	20	—	ns	
Read data hold time	t_{RDH}	0	—	ns	
Read data access time1	t_{ACC1}	—	$1.0 \times t_{cyc} - 48$	ns	
Read data access time2	t_{ACC2}	—	$1.5 \times t_{cyc} - 45$	ns	
Read data access time3	t_{ACC3}	—	$2.0 \times t_{cyc} - 45$	ns	
Read data access time 4	t_{ACC4}	—	$2.5 \times t_{cyc} - 45$	ns	
Read data access time 5	t_{ACC5}	—	$3.0 \times t_{cyc} - 50$	ns	
\overline{WR} delay time 1	t_{WRD1}	—	20	ns	
\overline{WR} delay time 2	t_{WRD2}	—	20	ns	
\overline{WR} pulse width 1	t_{WSW1}	$1.0 \times t_{cyc} - 20$	—	ns	
\overline{WR} pulse width 2	t_{WSW2}	$1.5 \times t_{cyc} - 20$	—	ns	
Write data delay time	t_{WDD}	—	30	ns	
Write data setup time	t_{WDS}	$0.5 \times t_{cyc} - 20$	—	ns	
Write data hold time	t_{WDH}	$0.5 \times t_{cyc} - 10$	—	ns	

(4) Timing of On-Chip Supporting Modules

Table 24-7 lists the timing of on-chip supporting modules.

Table 24-7 Timing of On-Chip Supporting Modules

Conditions: $V_{CC} = 4.5\text{ V to }5.5\text{ V}$, $PWMV_{CC} = 4.5\text{ V to }5.5\text{ V}$, $AV_{CC} = 4.5\text{ V to }5.5\text{ V}$,
 $V_{ref} = 4.5\text{ V to }AV_{CC}$, $V_{SS} = PWMV_{SS} = PLLV_{SS} = AV_{SS} = 0\text{ V}$,
 $T_a = -20^\circ\text{C to }+75^\circ\text{C}$ (regular specifications), $T_a = -40^\circ\text{C to }+85^\circ\text{C}$ (wide-range specifications)

Item	Symbol	Condition		Unit	Test Conditions	
		Min.	Max.			
I/O port	Output data delay time	t_{PWD}	—	50	ns	Figure 24-18
	Output data delay time 2	t_{PWD2}	—	50		Figure 24-19
	Input data setup time	t_{PRS}	30	—		
	Input data hold time	t_{PRH}	30	—		
PPG	Pulse output delay time	t_{POD}	—	50	ns	Figure 24-20
TPU	Timer output delay time	t_{TOCD}	—	50	ns	Figure 24-21
	Timer input setup time	t_{TICS}	30	—		
	Timer clock input setup time	t_{TCKS}	30	—	ns	Figure 24-22
	Timer clock pulse width	Single edge t_{TCKWH}	1.5	—	t_{cyc}	
	Both edges t_{TCKWL}	2.5	—			
PWM	Pulse output delay time	t_{MPWMOD}	—	50	ns	Figure 24-23
SCI	Input clock cycle	Asynchronous t_{Scyc}	4	—	t_{cyc}	Figure 24-24
		Synchronous	6	—		
	Input clock pulse width	t_{SCKW}	0.4	0.6	t_{Scyc}	
	Input clock rise time	t_{SCKr}	—	1.5	t_{cyc}	
	Input clock fall time	t_{SCKf}	—	1.5		
	Transmit data delay time	t_{TXD}	—	50	ns	Figure 24-25
	Receive data setup time (synchronous)	t_{RXS}	50	—		
	Receive data hold time (synchronous)	t_{RXH}	50	—		
A/D converter	Trigger input setup time	t_{TRGS}	50	—	ns	Figure 24-26

Item	Symbol	Condition		Unit	Test Conditions	
		Min.	Max.			
HCAN*	Transmit data delay time	t_{HTXD}	—	100	ns	Figure 24-27
	Receive data setup time	t_{HRXS}	100	—		
	Receive data hold time	t_{HRXH}	100	—		

Note: * The HCAN input signal is asynchronous. However, its state is judged to have changed at the leading edge (two clock cycles) of the CK clock signal shown in figure 24-27. The HCAN output signal is also asynchronous. Its state changes based on the leading edge (two clock cycles) of the CK clock signal shown in figure 24-27.

24.1.5 A/D Conversion Characteristics

Table 24-8 lists the A/D conversion characteristics.

Table 24-8 A/D Conversion Characteristics

Conditions: $V_{CC} = 4.5\text{ V to }5.5\text{ V}$, $PWMV_{CC} = 4.5\text{ V to }5.5\text{ V}$, $AV_{CC} = 4.5\text{ V to }5.5\text{ V}$,
 $V_{ref} = 4.5\text{ V to }AV_{CC}$, $V_{SS} = PWMV_{SS} = PLLV_{SS} = AV_{SS} = 0\text{ V}$,
 $T_a = -20^\circ\text{C to }+75^\circ\text{C}$ (regular specifications), $T_a = -40^\circ\text{C to }+85^\circ\text{C}$ (wide-range specifications)

Item	Condition			Unit
	Min.	Typ.	Max.	
Resolution	10	10	10	bits
Conversion time	10	—	—	μs
Analog input capacitance	—	—	20	pF
Permissible signal-source impedance	—	—	5	$\text{k}\Omega$
Nonlinearity error	—	—	± 3.5	LSB
Offset error	—	—	± 3.5	LSB
Full-scale error	—	—	± 3.5	LSB
Quantization	—	± 0.5	—	LSB
Absolute accuracy	—	—	± 4.0	LSB

24.1.6 D/A Conversion Characteristics

Table 24-9 shows the D/A conversion characteristics.

Table 24-9 D/A Conversion Characteristics

Conditions: $V_{CC} = 4.5\text{ V to }5.5\text{ V}$, $PWMV_{CC} = 4.5\text{ V to }5.5\text{ V}$, $AV_{CC} = 4.5\text{ V to }5.5\text{ V}$,
 $V_{ref} = 4.5\text{ V to }AV_{CC}$, $V_{SS} = PWMV_{SS} = PLLV_{SS} = AV_{SS} = 0\text{ V}$,
 $T_a = -20^\circ\text{C to }+75^\circ\text{C}$ (regular specifications), $T_a = -40^\circ\text{C to }+85^\circ\text{C}$ (wide-range specifications)

Item	Condition			Unit	Test Conditions
	Min.	Typ.	Max.		
Resolution	8	8	8	bits	
Conversion time	—	—	10	μs	20-pF capacitive load
Absolute accuracy	—	± 1.5	± 2.0	LSB	2-M Ω resistive load
	—	—	± 1.5	LSB	4-M Ω resistive load

24.1.7 Flash Memory Characteristics

Table 24-10 shows the flash memory characteristics.

Table 24-10 Flash Memory Characteristics

Conditions: $V_{CC}=4.5\text{ V to }5.5\text{ V}$, $PWMV_{CC}=4.5\text{ V to }5.5\text{ V}$, $AV_{CC}=4.5\text{ V to }5.5\text{ V}$,
 $V_{ref}=4.5\text{ V to }AV_{CC}$, $V_{SS}=PWMV_{SS}=PLL_{V_{SS}}$, $AV_{SS}=0\text{ V}$
 $T_a=0\text{ to }+75^\circ\text{C}$ (Programming/erasing operating temperature range: regular specification)

Item	Symbol	Min.	Typ.	Max.	Unit	Test Condition	
Programming time ^{*1 *2 *4}	t_P	—	10	200	ms/ 128 bytes		
Erase time ^{*1 *3 *5}	t_E	—	100	1200	ms/block		
Reprogramming count	N_{WEC}	—	—	100	Times		
Programming	Wait time after SWE bit setting ^{*1}	t_{SSWE}	1	1	—	μs	
	Wait time after PSU bit setting ^{*1}	t_{SPSU}	50	50	—	μs	
	Wait time after P bit setting ^{*1 *4}	t_{SP30}	28	30	32	μs	Programming time wait
		t_{SP200}	198	200	202	μs	Programming time wait
		t_{SP10}	8	10	12	μs	Additional-programming time wait
	Wait time after P bit clear ^{*1}	t_{CP}	5	5	—	μs	
	Wait time after PSU bit clear ^{*1}	t_{CPSU}	5	5	—	μs	
	Wait time after PV bit setting ^{*1}	t_{SPV}	4	4	—	μs	
	Wait time after H'FF dummy write ^{*1}	t_{SPVR}	2	2	—	μs	
	Wait time after PV bit clear ^{*1}	t_{CPV}	2	2	—	μs	
Wait time after SWE bit clear ^{*1}	t_{CSWE}	100	100	—	μs		
Maximum programming count ^{*1 *4}	N	—	—	1000	Times		
Erase	Wait time after SWE bit setting ^{*1}	t_{SSWE}	1	1	—	μs	
	Wait time after ESU bit setting ^{*1}	t_{SESU}	100	100	—	μs	
	Wait time after E bit setting ^{*1 *5}	t_{SE}	10	10	100	ms	Erase time wait
	Wait time after E bit clear ^{*1}	t_{CE}	10	10	—	μs	
	Wait time after ESU bit clear ^{*1}	t_{CESU}	10	10	—	μs	
	Wait time after EV bit setting ^{*1}	t_{SEV}	20	20	—	μs	

Item		Symbol	Min.	Typ.	Max.	Unit	Test Condition
Erase	Wait time after H'FF dummy write*1	t_{sevr}	2	2	—	μs	
	Wait time after EV bit clear*1	t_{cev}	4	4	—	μs	
	Wait time after SWE bit clear*1	t_{cswe}	100	100	—	μs	
	Maximum erase count*1 *5	N	12	—	120	Times	

- Notes: 1. Make each time setting in accordance with the program/program-verify flowchart or erase/erase-verify flowchart.
2. Programming time per 128 bytes (Shows the total period for which the P-bit in the flash memory control register (FLMCR1) is set. It does not include the programming verification time)
3. Block erase time (Shows the total period for which the E-bit in FLMCR1 is set. It does not include the erase verification time)
4. To specify the maximum programming time value (t_p (max.)) in the 128-byte programming algorithm, set the max. value (1000) for the maximum programming count (N).

The wait time after P bit setting should be changed as follows according to the value of the programming counter (n).

Programming counter (n) = 1 to 6: $t_{sp30} = 30 \mu\text{s}$

Programming counter (n) = 7 to 1000: $t_{sp200} = 200 \mu\text{s}$

[In additional programming]

Programming counter (n)= 1 to 6: $t_{sp10} = 10 \mu\text{s}$

5. For the maximum erase time (t_E (max.)), the following relationship applies between the wait time after E bit setting (t_{se}) and the maximum erase count (N):

$$t_E \text{ (max.)} = \text{Wait time after E bit setting (} t_{se} \text{) } \times \text{ maximum erase count (N)}$$

To set the maximum erase time, the values of (t_{se}) and (N) should be set so as to satisfy the above formula.

Examples: When $t_{se} = 100$ [ms], N = 12 times

When $t_{se} = 10$ [ms], N = 120 times

24.2 H8S/2638 Group Electrical Characteristics

24.2.1 Absolute Maximum Ratings

Table 24-11 lists the absolute maximum ratings.

Table 24-11 Absolute Maximum Ratings

Item	Symbol	Value	Unit
Power supply voltage	V_{CC}	-0.3 to +7.0	V
Input voltage (OSC1, OSC2)	V_{in}	-0.3 +4.3	V
Input voltage (XTAL, EXTAL)	V_{in}	-0.3 to $V_{CC} + 0.3$	V
Input voltage (ports 4 and 9)	V_{in}	-0.3 to $AV_{CC} + 0.3$	V
Input voltage (ports H and J)	V_{in}	-0.3 to $PWMV_{CC} + 0.3$	V
Input voltage (except XTAL, EXTAL, OSC1, OSC2, ports 4, 9, H and J)	V_{in}	-0.3 to $V_{CC} + 0.3$	V
Reference voltage	V_{ref}	-0.3 to $AV_{CC} + 0.3$	V
Analog power supply voltage	AV_{CC}	-0.3 to +7.0	V
Analog input voltage	V_{AN}	-0.3 to $AV_{CC} + 0.3$	V
Operating temperature	T_{opr}	Regular specifications: -20 to +75	°C
		Wide-range specifications: -40 to +85	°C
Storage temperature	T_{stg}	-55 to +125	°C

Caution: Permanent damage to the chip may result if absolute maximum rating are exceeded.

24.2.2 Power Supply Voltage and Operating Frequency Range

Power supply voltage and operating frequency ranges (shaded areas) are shown in figure 24-3.

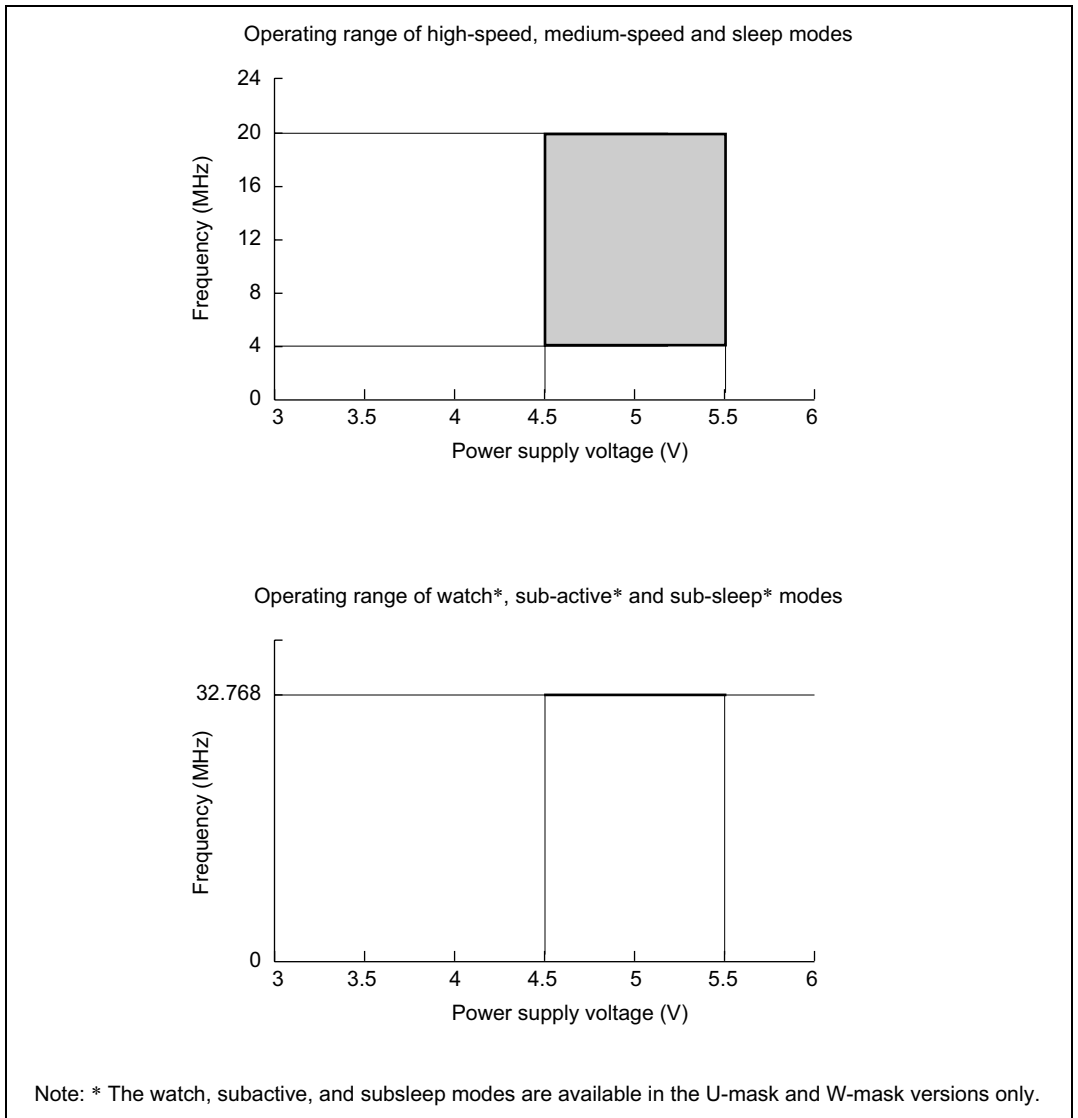

Figure 24-3 Power Supply Voltage and Operating Ranges

24.2.3 DC Characteristics

Table 24-12 lists the DC characteristics. Table 24-13 lists the permissible output currents.

Table 24-12 DC Characteristics

Conditions: $V_{CC} = 4.5\text{ V to }5.5\text{ V}$, $PWMV_{CC} = 4.5\text{ V to }5.5\text{ V}$, $AV_{CC} = 4.5\text{ V to }5.5\text{ V}$,
 $V_{ref} = 4.5\text{ V to }AV_{CC}$, $V_{SS} = PWMV_{SS} = PLLV_{SS} = AV_{SS} = 0\text{ V}$, $T_a = -20^\circ\text{C to }+75^\circ\text{C}$
 (regular specifications), $T_a = -40^\circ\text{C to }+85^\circ\text{C}$ (wide-range specifications)*1 *6

Item	Symbol	Min.	Typ.	Max.	Unit	Test Conditions
Schmitt trigger input voltage	IRQ0 to IRQ5	V_T^-	1.0	—	—	V
		V_T^+	—	—	$V_{CC} \times 0.7$	
		$V_T^+ - V_T^-$	0.4	—	—	
Input high voltage	\overline{RES} , \overline{STBY} , NMI, FWE, MD2 to MD0	V_{IH}	$V_{CC} - 0.7$	—	$V_{CC} + 0.3$	V
	EXTAL		$V_{CC} \times 0.7$	—	$V_{CC} + 0.3$	
	Ports 1, 3, F		2.2	—	$V_{CC} + 0.3$	
	Ports A to E		$V_{CC} \times 0.8$	—	$V_{CC} + 0.3$	
	Ports H, J		$PWMV_{CC} \times 0.8$	—	$PWMV_{CC} + 0.3$	
	HRxD0, HRxD1		2.2	—	$V_{CC} + 0.3$	
	Ports 4 and 9		$AV_{CC} \times 0.7$	—	$AV_{CC} + 0.3$	
Input low voltage	\overline{RES} , \overline{STBY} , NMI, FWE, MD2 to MD0	V_{IL}	-0.3	—	0.5	V
	EXTAL		-0.3	—	0.8	
	Ports 1, 3, F		-0.3	—	0.8	
	Ports A to E		-0.3	—	$V_{CC} \times 0.2$	
	Ports H, J		-0.3	—	$PWMV_{CC} \times 0.2$	
	HRxD0, HRxD1		-0.3	—	$V_{CC} \times 0.2$	
	Ports 4, 9		-0.3	—	$AV_{CC} \times 0.2$	

Item	Symbol	Min.	Typ.	Max.	Unit	Test Conditions	
Output high voltage	Ports 1, 3, A to F, H, J HTxD0, HTxD1 (excluding P34 and P35 ^{*7})	V_{OH}	$V_{CC} - 0.5$	—	—	V	$I_{OH} = -200 \mu A$
	P34, P35 ^{*7}		$V_{CC} - 2.5$	—	—		$I_{OH} = -100 \mu A$
	Ports 1, 3, A to F, H, J HTxD0, HTxD1 (excluding P34 and P35 ^{*7})		3.5	—	—		$I_{OH} = -1 \text{ mA}$
	PWM1A to PWM1H, PWM2A to PWM2H		$PWMV_{CC} - 0.5$	—	—		$I_{OH} = -15 \text{ mA}$
Output low voltage	All output pins except PWM1A to PWM1H, PWM2A to PWM2H	V_{OL}	—	—	0.4	V	$I_{OL} = 1.6 \text{ mA}$
	PWM1A to PWM1H, PWM2A to PWM2H		—	—	0.5	V	$I_{OL} = 15 \text{ mA}$
Input leakage current	\overline{RES}	$ I_{in} $	—	—	1.0	μA	$V_{in} = 0.5 \text{ V to } V_{CC} - 0.5 \text{ V}$
	\overline{STBY} , \overline{NMI} , MD2 to MD0		—	—	1.0		
	HRxD0, HRxD1, FWE		—	—	1.0		
	Ports 4, 9		—	—	1.0		$V_{in} = 0.5 \text{ V to } AV_{CC} - 0.5 \text{ V}$
Three-state leakage current (off state)	Ports 1, 3, A to F, H, J HTxD0, HTxD1	$ I_{TSI} $	—	—	1.0	μA	$V_{in} = 0.5 \text{ V to } V_{CC} - 0.5 \text{ V}$

Item		Symbol	Min.	Typ.	Max.	Unit	Test Conditions
MOS input pull-up current	Ports A to E	$-I_P$	50		300	μA	$V_{in} = 0\text{ V}$
Input capacitance	$\overline{\text{RES}}$	C_{in}	—	—	30	pF	$V_{in} = 0\text{ V}$
	NMI		—	—	30		$f = 1\text{ MHz}$
	All input pins except $\overline{\text{RES}}$ and NMI		—	—	15		$T_a = 25^\circ\text{C}$
Current dissipation*2	Normal operation	I_{CC}^{*4}	—	75	90	mA	$f = 20\text{ MHz}$
	Sleep mode		—	65	80		
	All modules stopped		—	57	—	mA	$f = 20\text{ MHz}$ (reference value)
	Medium-speed mode ($\phi/32$)		—	49	—		
	Subactive mode*5		—	130	220	μA	Using 32.768 kHz crystal resonator
	Subsleep mode*5		—	80	160		
	Watch mode*5		—	30	60		
	Standby mode*3		—	2.0	5.0	μA	$T_a \leq 50^\circ\text{C}$ $50^\circ\text{C} < T_a$
Analog power supply current	During A/D and D/A conversion	I_{CC}	—	1.0	2.0	mA	$AV_{CC} = 5.0\text{ V}$
	Idle		—	0.1	5.0	μA	
Reference current	During A/D and D/A conversion	I_{CC}	—	4.0	5.0	mA	$V_{ref} = 5.0\text{ V}$
	Idle		—	0.1	5.0	μA	
RAM standby voltage		V_{RAM}	2.0	—	—	V	

Notes: 1. If the A/D and D/A converters are not used, do not leave the AV_{CC} , V_{ref} , and AV_{SS} pins open. Apply a voltage between 4.5 V and 5.5 V to the AV_{CC} and V_{ref} pins by connecting them to V_{CC} , for instance. Set $V_{ref} \leq AV_{CC}$.

2. Current dissipation values are for $V_{IH}(\text{min.}) = V_{CC} - 0.5\text{ V}$, $V_{IL}(\text{max.}) = 0.5\text{ V}$ with all output pins unloaded and the on-chip pull-up resistors in the off state.

3. The values are for $V_{RAM} \leq V_{CC} < 3.0\text{ V}$, $V_{IH}(\text{min.}) = V_{CC} \times 0.9$, and $V_{IL}(\text{max.}) = 0.3\text{ V}$.

4. I_{CC} depends on V_{CC} and f as follows:

$$I_{CC} (\text{max.}) = 30 (\text{mA}) + 0.54 (\text{mA}/(\text{MHz} \times \text{V})) \times V_{CC} \times f (\text{normal operation})$$

$$I_{CC} (\text{max.}) = 30 (\text{mA}) + 0.45 (\text{mA}/(\text{MHz} \times \text{V})) \times V_{CC} \times f (\text{sleep mode})$$

5. The watch, subactive, and subsleep modes are available in the U-mask and W-mask versions only.

See section 22A.7, Subclock Oscillator, for the method of fixing pins OSC1 and OSC2.

6. If the motor-control PWM timer is not used, do not leave the $PMWV_{CC}$, or $PMWV_{SS}$ pins open. If the motor-control PWM timer is not used, apply a voltage of between 4.5 and 5.5 V to the $PMWV_{CC}$ pin, for instance, by connecting it to V_{CC} .
7. The characteristics of pins 34 and 35 apply to the W-mask version.

Table 24-13 Permissible Output Currents

Conditions: $V_{CC} = 4.5\text{ V to }5.5\text{ V}$, $PWMV_{CC} = 4.5\text{ V to }5.5\text{ V}$, $AV_{CC} = 4.5\text{ V to }5.5\text{ V}$,
 $V_{ref} = 4.5\text{ V to }AV_{CC}$, $V_{SS} = PWMV_{SS} = PLLV_{SS} = AV_{SS} = 0\text{ V}$, $T_a = -20^\circ\text{C to }+75^\circ\text{C}$
 (regular specifications), $T_a = -40^\circ\text{C to }+85^\circ\text{C}$ (wide-range specifications)

Item		Symbol	Min.	Typ.	Max.	Unit	Test condition
Permissible output low current (per pin)	All output pins except PWM1A to PWM1H, PWM2A to PWM2H	I_{OL}	—	—	10	mA	
	PWM1A to PWM1H, PWM2A to PWM2H	I_{OL}	—	—	25	mA	$T_a = 85^\circ\text{C}$
			—	—	30	mA	$T_a = 25^\circ\text{C}$
			—	—	40	mA	$T_a = -40^\circ\text{C}$
Permissible output low current (total)	Total of all output pins excepting PWM1A to PWM1H, and PWM2A to PWM2H	ΣI_{OL}	—	—	80	mA	
	Total of PWM1A to PWM1H, and PWM2A to PWM2H	ΣI_{OL}	—	—	150	mA	$T_a = 85^\circ\text{C}$
			—	—	180	mA	$T_a = 25^\circ\text{C}$
			—	—	220	mA	$T_a = -40^\circ\text{C}$
Permissible output high current (per pin)	All output pins except PWM1A to PWM1H, PWM2A to PWM2H	$-I_{OH}$	—	—	2.0	mA	
	PWM1A to PWM1H, PWM2A to PWM2H	$-I_{OH}$	—	—	25	mA	$T_a = 85^\circ\text{C}$
			—	—	30	mA	$T_a = 25^\circ\text{C}$
			—	—	40	mA	$T_a = -40^\circ\text{C}$
Permissible output high current (total)	Total of all output pins excepting PWM1A to PWM1H, and PWM2A to PWM2H	$-\Sigma I_{OH}$	—	—	40	mA	
	Total of PWM1A to PWM1H, and PWM2A to PWM2H	$-\Sigma I_{OH}$	—	—	150	mA	$T_a = 85^\circ\text{C}$
			—	—	180	mA	$T_a = 25^\circ\text{C}$
			—	—	220	mA	$T_a = -40^\circ\text{C}$

Note: To protect chip reliability, do not exceed the output current values in table 24-13.

Table 24-14 Bus Drive Characteristics [Option]*

Conditions: $V_{CC} = 4.5\text{ V to }5.5\text{ V}$, $PWMV_{CC} = 4.5\text{ V to }5.5\text{ V}$, $AV_{CC} = 4.5\text{ V to }5.5\text{ V}$,
 $V_{ref} = 4.5\text{ V to }AV_{CC}$, $V_{SS} = PWMV_{SS} = PLLV_{SS} = AV_{SS} = 0\text{ V}$, $T_a = -20^\circ\text{C to }+75^\circ\text{C}$
 (regular specifications), $T_a = -40^\circ\text{C to }+85^\circ\text{C}$ (wide-range specifications)

Applicable Pins: SCL1-0, SDA1-0

Item	Symbol	Min.	Typ.	Max.	Unit	Test Conditions
Schmitt trigger input voltage	V_{T^-}	1.0	—	—	V	
	V_{T^+}	—	—	$V_{CC} \times 0.7$		
	$V_{T^+} - V_{T^-}$	0.4	—	—		$V_{CC} = 4.5\text{ V to }5.5\text{ V}$
Input high voltage	V_{IH}	$-V_{CC} \times 0.7$	—	$V_{CC} + 0.5$	V	
Input low voltage	V_{IL}	-0.5	—	$V_{CC} \times 0.3$	V	
Output low voltage	V_{OL}	—	—	0.7	V	$I_{OL} = 8\text{ mA}$, $V_{CC} = 4.5\text{ V to }5.5\text{ V}$
		—	—	0.4		$I_{OL} = 3\text{ mA}$, $V_{CC} = 4.5\text{ V to }5.5\text{ V}$
		—	—	0.4		$I_{OL} = 1.6\text{ mA}$, $V_{CC} = 3.3\text{ V to }5.5\text{ V}$
Input capacitance	C_{in}	—	—	20	pF	$V_{in} = 0\text{ V}$, $f = 1\text{ MHz}$, $T_a = 25^\circ\text{C}$
Three-state leakage current (off state)	$ I_{TSL} $	—	—	1.0	μA	$V_{in} = 0.5\text{ V to }V_{CC}$ - 5.5 V
SCL, SDA, output fall time	t_{of}	$20 + 0.1Cb$	—	250	ns	

Note: * Available when using I²C bus interface (the W-mask version only).

24.2.4 AC Characteristics

Figure 24-4 show, the test conditions for the AC characteristics.

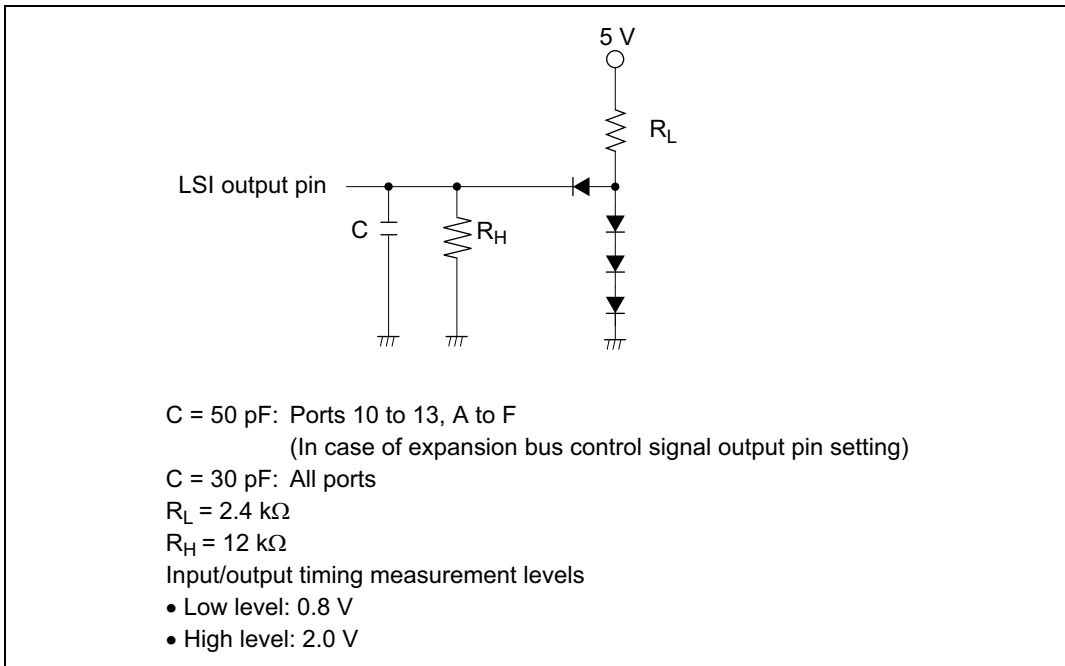

Figure 24-4 Output Load Circuit

(1) Clock Timing

Table 24-15 lists the clock timing

Table 24-15 Clock Timing

Conditions: $V_{CC} = 4.5\text{ V to }5.5\text{ V}$, $PWMV_{CC} = 4.5\text{ V to }5.5\text{ V}$, $AV_{CC} = 4.5\text{ V to }5.5\text{ V}$,
 $V_{ref} = 4.5\text{ V to }AV_{CC}$, $V_{SS} = PWMV_{SS} = PLLV_{SS} = AV_{SS} = 0\text{ V}$,
 $T_a = -20^\circ\text{C to }+75^\circ\text{C}$ (regular specifications), $T_a = -40^\circ\text{C to }+85^\circ\text{C}$ (wide-range specifications)

Item	Symbol	Condition		Unit	Test Conditions
		20MHz			
		Min.	Max.		
Clock cycle time	t_{cyc}	50	250	ns	Figure 24-9
Clock high pulse width	t_{CH}	15	—	ns	
Clock low pulse width	t_{CL}	15	—	ns	
Clock rise time	t_{Cr}	—	10	ns	
Clock fall time	t_{Cf}	—	10	ns	
Clock oscillator settling time at reset (crystal)	t_{OSC1}	20	—	ms	Figure 24-10
Clock oscillator settling time in software standby (crystal)	t_{OSC2}	8	—	ms	Figure 23A-3 Figure 23B-3
External clock output stabilization delay time	t_{DEXT}	2	—	ms	Figure 24-10
32-kHz clock oscillation settling time	t_{OSC3}	—	2	s	
Subclock oscillator frequency	f_{SUB}	32.768		kHz	
Subclock (ϕ_{SUB}) cycle time	t_{SUB}	30.5		μs	

(2) Control Signal Timing

Table 24-16 lists the control signal timing.

Table 24-16 Control Signal Timing

Conditions: $V_{CC} = 4.5 \text{ V to } 5.5 \text{ V}$, $PWMV_{CC} = 4.5 \text{ V to } 5.5 \text{ V}$, $AV_{CC} = 4.5 \text{ V to } 5.5 \text{ V}$,
 $V_{ref} = 4.5 \text{ V to } AV_{CC}$, $V_{SS} = PWMV_{SS} = PLLV_{SS} = AV_{SS} = 0 \text{ V}$,
 $T_a = -20^\circ\text{C to } +75^\circ\text{C}$ (regular specifications), $T_a = -40^\circ\text{C to } +85^\circ\text{C}$ (wide-range specifications)

Item	Symbol	Condition		Unit	Test Conditions
		Min.	Max.		
$\overline{\text{RES}}$ setup time	t_{RESS}	200	—	ns	Figure 24-11
$\overline{\text{RES}}$ pulse width	t_{RESW}	20	—	t_{cyc}	
NMI setup time	t_{NMIS}	150	—	ns	Figure 24-12
NMI hold time	t_{NMIH}	10	—		
NMI pulse width (exiting software standby mode)	t_{NMIW}	200	—	ns	
$\overline{\text{IRQ}}$ setup time	t_{IRQS}	150	—	ns	
$\overline{\text{IRQ}}$ hold time	t_{IRQH}	10	—	ns	
$\overline{\text{IRQ}}$ pulse width (exiting software standby mode)	t_{IRQW}	200	—	ns	

(3) Bus Timing

Table 24-17 lists the bus timing.

Table 24-17 Bus Timing

Conditions: $V_{CC} = 4.5\text{ V to }5.5\text{ V}$, $PWMV_{CC} = 4.5\text{ V to }5.5\text{ V}$, $AV_{CC} = 4.5\text{ V to }5.5\text{ V}$,
 $V_{ref} = 4.5\text{ V to }AV_{CC}$, $V_{SS} = PWMV_{SS} = PLLV_{SS} = AV_{SS} = 0\text{ V}$,
 $T_a = -20^{\circ}\text{C to }+75^{\circ}\text{C}$ (regular specifications), $T_a = -40^{\circ}\text{C to }+85^{\circ}\text{C}$ (wide-range specifications)

Item	Symbol	Condition		Unit	Test Conditions
		Min.	Max.		
Address delay time	t_{AD}	—	35	ns	Figure 24-13 to Figure 24-17
Address setup time	t_{AS}	$0.5 \times t_{cyc} - 20$	—	ns	
Address hold time	t_{AH}	$0.5 \times t_{cyc} - 15$	—	ns	
\overline{AS} delay time	t_{ASD}	—	20	ns	
\overline{RD} delay time 1	t_{RSD1}	—	20	ns	
\overline{RD} delay time 2	t_{RSD2}	—	20	ns	
Read data setup time	t_{RDS}	20	—	ns	
Read data hold time	t_{RDH}	0	—	ns	
Read data access time1	t_{ACC1}	—	$1.0 \times t_{cyc} - 48$	ns	
Read data access time2	t_{ACC2}	—	$1.5 \times t_{cyc} - 45$	ns	
Read data access time3	t_{ACC3}	—	$2.0 \times t_{cyc} - 45$	ns	
Read data access time 4	t_{ACC4}	—	$2.5 \times t_{cyc} - 45$	ns	
Read data access time 5	t_{ACC5}	—	$3.0 \times t_{cyc} - 50$	ns	
\overline{WR} delay time 1	t_{WRD1}	—	20	ns	
\overline{WR} delay time 2	t_{WRD2}	—	20	ns	
\overline{WR} pulse width 1	t_{WSW1}	$1.0 \times t_{cyc} - 20$	—	ns	
\overline{WR} pulse width 2	t_{WSW2}	$1.5 \times t_{cyc} - 20$	—	ns	
Write data delay time	t_{WDD}	—	30	ns	
Write data setup time	t_{WDS}	$0.5 \times t_{cyc} - 20$	—	ns	
Write data hold time	t_{WDH}	$0.5 \times t_{cyc} - 10$	—	ns	

(4) Timing of On-Chip Supporting Modules

Table 24-18 lists the timing of on-chip supporting modules.

Table 24-18 Timing of On-Chip Supporting Modules

Conditions: $V_{CC} = 4.5\text{ V to }5.5\text{ V}$, $PWMV_{CC} = 4.5\text{ V to }5.5\text{ V}$, $AV_{CC} = 4.5\text{ V to }5.5\text{ V}$,
 $V_{ref} = 4.5\text{ V to }AV_{CC}$, $V_{SS} = PWMV_{SS} = PLLV_{SS} = AV_{SS} = 0\text{ V}$,
 $T_a = -20^\circ\text{C to }+75^\circ\text{C}$ (regular specifications), $T_a = -40^\circ\text{C to }+85^\circ\text{C}$ (wide-range specifications)

Item	Symbol	Condition		Unit	Test Conditions		
		Min.	Max.				
I/O port	Output data delay time	t_{PWD}	—	50	ns	Figure 24-18	
	Output data delay time 2	t_{PWD2}	—	50		Figure 24-19	
	Input data setup time	t_{PRS}	30	—			
	Input data hold time	t_{PRH}	30	—			
PPG	Pulse output delay time	t_{POD}	—	50	ns	Figure 24-20	
TPU	Timer output delay time	t_{TOCD}	—	50	ns	Figure 24-21	
	Timer input setup time	t_{TICS}	30	—			
	Timer clock input setup time	t_{TCKS}	30	—	ns	Figure 24-22	
	Timer clock pulse width	Single edge	t_{TCKWH}	1.5	—	t_{cyc}	
Both edges		t_{TCKWL}	2.5	—			
PWM	Pulse output delay time	t_{MPWMOD}	—	50	ns	Figure 24-23	
SCI	Input clock cycle	Asynchronous	t_{Scyc}	4	—	t_{cyc}	Figure 24-24
		Synchronous		6	—		
	Input clock pulse width	t_{SCKW}	0.4	0.6	t_{Scyc}		
	Input clock rise time	t_{SCKr}	—	1.5	t_{cyc}		
	Input clock fall time	t_{SCKf}	—	1.5			
	Transmit data delay time	t_{TXD}	—	50	ns	Figure 24-25	
	Receive data setup time (synchronous)	t_{RXS}	50	—			
Receive data hold time (synchronous)	t_{RXH}	50	—				
A/D converter	Trigger input setup time	t_{TRGS}	50	—	ns	Figure 24-26	

Item	Symbol	Condition		Unit	Test Conditions	
		Min.	Max.			
HCAN*	Transmit data delay time	t_{HTXD}	—	100	ns	Figure 24-27
	Receive data setup time	t_{HRXS}	100	—		
	Receive data hold time	t_{HRXH}	100	—		

Note: * The HCAN input signal is asynchronous. However, its state is judged to have changed at the leading edge (two clock cycles) of the CK clock signal shown in figure 24-27. The HCAN output signal is also asynchronous. Its state changes based on the leading edge (two clock cycles) of the CK clock signal shown in figure 24-27.

Table 24-19 I²C Bus Timing [Option]*¹

Conditions: $V_{CC} = 4.5\text{ V to }5.5\text{ V}$, $PWMV_{CC} = 4.5\text{ V to }5.5\text{ V}$, $AV_{CC} = 4.5\text{ V to }5.5\text{ V}$,
 $V_{ref} = 4.5\text{ V to }AV_{CC}$, $V_{SS} = PWMV_{SS} = PLLV_{SS} = AV_{SS} = 0\text{ V}$,
 $\phi = 5\text{ MHz to maximum operating frequency}$, $T_a = -20^\circ\text{C to }+75^\circ\text{C}$
(regular specifications), $T_a = -40^\circ\text{C to }+85^\circ\text{C}$ (wide-range specifications)

Item	Symbol	Condition			Unit	Notes
		Min.	Typ.	Max.		
SCL input cycle time	t_{SCL}	$12t_{cyc}$	—	—	ns	Figure 24-28
SCL input high pulse width	t_{SCLH}	$3t_{cyc}$	—	—	ns	
SCL input low pulse width	t_{SCLL}	$5t_{cyc}$	—	—	ns	
SCL, SDA input rise time	t_{Sr}	—	—	$7.5t_{cyc}^{*2}$	ns	
SCL, SDA input fall time	t_{Sf}	—	—	300	ns	
SCL, SDA input spike pulse elimination time	t_{SP}	—	—	$1t_{cyc}$	ns	
SDA input bus free time	t_{BUF}	$5t_{cyc}$	—	—	ns	
Start condition input hold time	t_{STAH}	$3t_{cyc}$	—	—	ns	
Retransmission start condition input setup time	t_{STAS}	$3t_{cyc}$	—	—	ns	
Stop condition input setup time	t_{STOS}	$3t_{cyc}$	—	—	ns	
Data input setup time	t_{SDAS}	$0.5t_{cyc}$	—	—	ns	
Data input hold time	t_{SDAH}	0	—	—	ns	
SCL, SDA capacitive load	C_b	—	—	400	pF	

Notes: 1. Available when using I²C bus interface (the W-mask version only).

2. $17.5t_{cyc}$ can be set according to the clock selected for use by the I²C module. For details, see section 15.4, Usage Notes.

24.2.5 A/D Conversion Characteristics

Table 24-20 lists the A/D conversion characteristics.

Table 24-20 A/D Conversion Characteristics

Conditions: $V_{CC} = 4.5\text{ V to }5.5\text{ V}$, $PWMV_{CC} = 4.5\text{ V to }5.5\text{ V}$, $AV_{CC} = 4.5\text{ V to }5.5\text{ V}$,
 $V_{ref} = 4.5\text{ V to }AV_{CC}$, $V_{SS} = PWMV_{SS} = PLLV_{SS} = AV_{SS} = 0\text{ V}$,
 $T_a = -20^\circ\text{C to }+75^\circ\text{C}$ (regular specifications), $T_a = -40^\circ\text{C to }+85^\circ\text{C}$ (wide-range specifications)

Item	Condition			Unit
	Min.	Typ.	Max.	
Resolution	10	10	10	bits
Conversion time	10	—	—	μs
Analog input capacitance	—	—	20	pF
Permissible signal-source impedance	—	—	5	k Ω
Nonlinearity error	—	—	± 3.5	LSB
Offset error	—	—	± 3.5	LSB
Full-scale error	—	—	± 3.5	LSB
Quantization	—	± 0.5	—	LSB
Absolute accuracy	—	—	± 4.0	LSB

24.2.6 D/A Conversion Characteristics

Table 24-21 shows the D/A conversion characteristics.

Table 24-21 D/A Conversion Characteristics

Conditions: $V_{CC} = 4.5\text{ V to }5.5\text{ V}$, $PWMV_{CC} = 4.5\text{ V to }5.5\text{ V}$, $AV_{CC} = 4.5\text{ V to }5.5\text{ V}$,
 $V_{ref} = 4.5\text{ V to }AV_{CC}$, $V_{SS} = PWMV_{SS} = PLLV_{SS} = AV_{SS} = 0\text{ V}$,
 $T_a = -20^\circ\text{C to }+75^\circ\text{C}$ (regular specifications), $T_a = -40^\circ\text{C to }+85^\circ\text{C}$ (wide-range specifications)

Item	Condition			Unit	Test Conditions
	Min.	Typ.	Max.		
Resolution	8	8	8	bits	
Conversion time	—	—	10	μs	20-pF capacitive load
Absolute accuracy	—	± 1.5	± 2.0	LSB	2-M Ω resistive load
	—	—	± 1.5	LSB	4-M Ω resistive load

24.2.7 Flash Memory Characteristics

Table 24-22 shows the flash memory characteristics.

Table 24-22 Flash Memory Characteristics

Conditions: $V_{CC}=4.5\text{ V to }5.5\text{ V}$, $PWMV_{CC}=4.5\text{ V to }5.5\text{ V}$, $AV_{CC}=4.5\text{ V to }5.5\text{ V}$,
 $V_{ref}=4.5\text{ V to }AV_{CC}$, $V_{SS}=PWMV_{SS}=PLL_{V_{SS}}$, $AV_{SS}=0\text{ V}$
 $T_a=0\text{ to }+75^\circ\text{C}$ (Programming/erasing operating temperature range: regular specification)

Item	Symbol	Min.	Typ.	Max.	Unit	Test Condition	
Programming time ^{*1 *2 *4}	t_P	—	10	200	ms/ 128 bytes		
Erase time ^{*1 *3 *5}	t_E	—	100	1200	ms/block		
Reprogramming count	N_{WEC}	—	—	100	Times		
Programming	Wait time after SWE bit setting ^{*1}	t_{SSWE}	1	1	—	μs	
	Wait time after PSU bit setting ^{*1}	t_{SPSU}	50	50	—	μs	
	Wait time after P bit setting ^{*1 *4}	t_{SP30}	28	30	32	μs	Programming time wait
		t_{SP200}	198	200	202	μs	Programming time wait
		t_{SP10}	8	10	12	μs	Additional-programming time wait
	Wait time after P bit clear ^{*1}	t_{CP}	5	5	—	μs	
	Wait time after PSU bit clear ^{*1}	t_{CPSU}	5	5	—	μs	
	Wait time after PV bit setting ^{*1}	t_{SPV}	4	4	—	μs	
	Wait time after H'FF dummy write ^{*1}	t_{SPVR}	2	2	—	μs	
	Wait time after PV bit clear ^{*1}	t_{CPV}	2	2	—	μs	
Wait time after SWE bit clear ^{*1}	t_{CSWE}	100	100	—	μs		
Maximum programming count ^{*1 *4}	N	—	—	1000	Times		
Erase	Wait time after SWE bit setting ^{*1}	t_{SSWE}	1	1	—	μs	
	Wait time after ESU bit setting ^{*1}	t_{SESU}	100	100	—	μs	
	Wait time after E bit setting ^{*1 *5}	t_{SE}	10	10	100	ms	Erase time wait
	Wait time after E bit clear ^{*1}	t_{CE}	10	10	—	μs	
	Wait time after ESU bit clear ^{*1}	t_{CESU}	10	10	—	μs	
	Wait time after EV bit setting ^{*1}	t_{SEV}	20	20	—	μs	

Item		Symbol	Min.	Typ.	Max.	Unit	Test Condition
Erase	Wait time after H'FF dummy write*1	t_{sevr}	2	2	—	μs	
	Wait time after EV bit clear*1	t_{cev}	4	4	—	μs	
	Wait time after SWE bit clear*1	t_{cswe}	100	100	—	μs	
	Maximum erase count*1 *5	N	12	—	120	Times	

- Notes: 1. Make each time setting in accordance with the program/program-verify flowchart or erase/erase-verify flowchart.
2. Programming time per 128 bytes (Shows the total period for which the P-bit in the flash memory control register (FLMCR1) is set. It does not include the programming verification time)
3. Block erase time (Shows the total period for which the E-bit in FLMCR1 is set. It does not include the erase verification time)
4. To specify the maximum programming time value (t_p (max.)) in the 128-byte programming algorithm, set the max. value (1000) for the maximum programming count (N).

The wait time after P bit setting should be changed as follows according to the value of the programming counter (n).

Programming counter (n) = 1 to 6: $t_{sp30} = 30 \mu\text{s}$

Programming counter (n) = 7 to 1000: $t_{sp200} = 200 \mu\text{s}$

[In additional programming]

Programming counter (n)= 1 to 6: $t_{sp10} = 10 \mu\text{s}$

5. For the maximum erase time (t_E (max.)), the following relationship applies between the wait time after E bit setting (t_{se}) and the maximum erase count (N):

$$t_E \text{ (max.)} = \text{Wait time after E bit setting (} t_{se} \text{) x maximum erase count (N)}$$

To set the maximum erase time, the values of (t_{se}) and (N) should be set so as to satisfy the above formula.

Examples: When $t_{se} = 100$ [ms], N = 12 times

When $t_{se} = 10$ [ms], N = 120 times

24.3 H8S/2639 Group, H8S/2635 Group Electrical Characteristics

24.3.1 Absolute Maximum Ratings

Table 24-23 lists the absolute maximum ratings.

Table 24-23 Absolute Maximum Ratings

Item	Symbol	Value	Unit
Power supply voltage	V_{CC}	-0.3 to +7.0	V
Input voltage (XTAL*, EXTAL)	V_{in}	-0.3 to $V_{CC} + 0.3$	V
Input voltage (ports 4 and 9)	V_{in}	-0.3 to $AV_{CC} + 0.3$	V
Input voltage (ports H and J)	V_{in}	-0.3 to $PWMV_{CC} + 0.3$	V
Input voltage (except XTAL, EXTAL, ports 4, 9, H and J)	V_{in}	-0.3 to $V_{CC} + 0.3$	V
Reference voltage	V_{ref}	-0.3 to $AV_{CC} + 0.3$	V
Analog power supply voltage	AV_{CC}	-0.3 to +7.0	V
Analog input voltage	V_{AN}	-0.3 to $AV_{CC} + 0.3$	V
Operating temperature	T_{opr}	Regular specifications: -20 to +75	°C
		Wide-range specifications: -40 to +85	°C
Storage temperature	T_{stg}	-55 to +125	°C

Caution: Permanent damage to the chip may result if absolute maximum rating are exceeded.

Note: * In the case of the H8S/2635 Group, do not input a signal to the XTAL pin.

24.3.2 Power Supply Voltage and Operating Frequency Range

Power supply voltage and operating frequency ranges (shaded areas) are shown in figure 24-5.

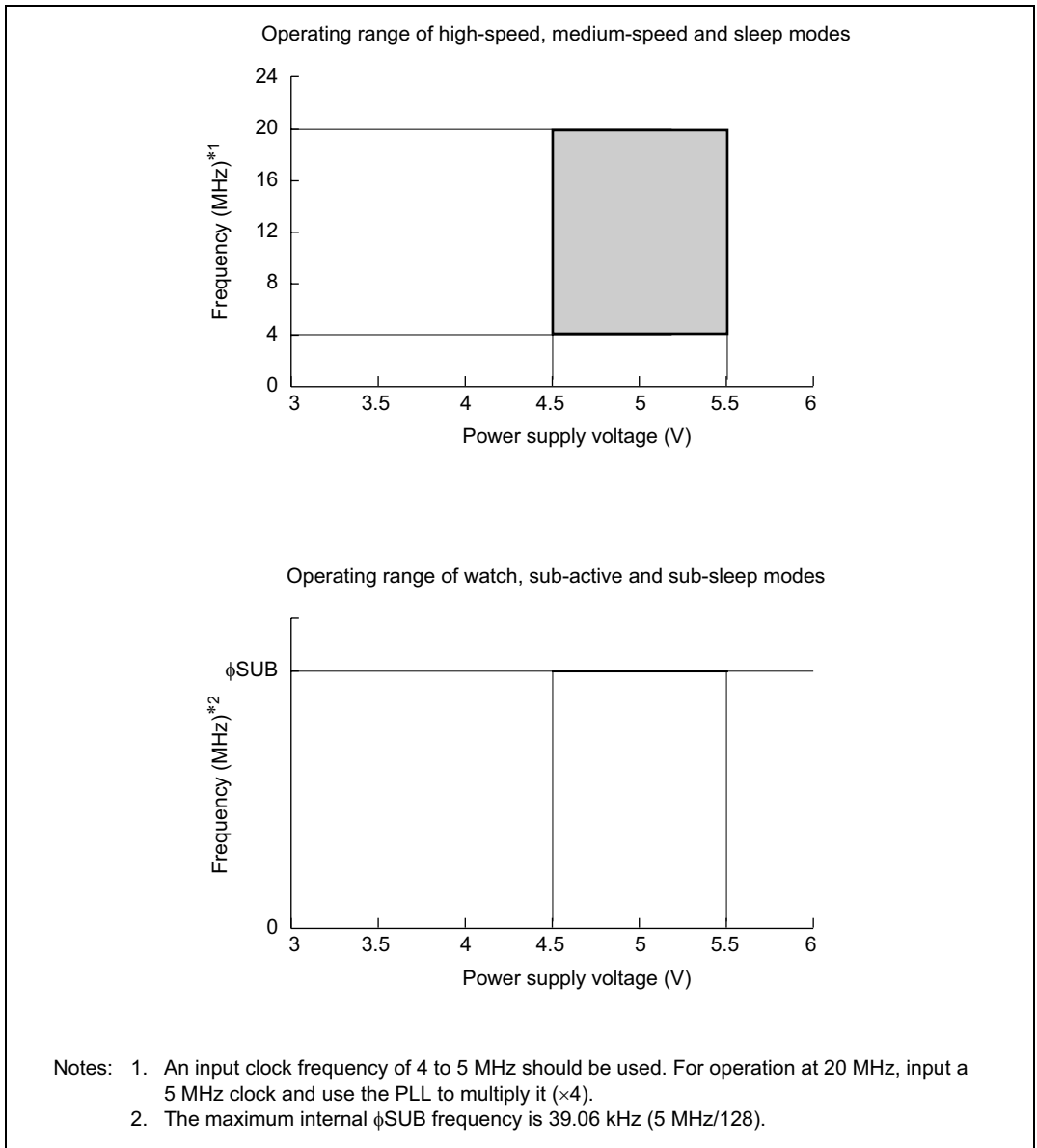

Figure 24-5 Power Supply Voltage and Operating Ranges

24.3.3 DC Characteristics

Table 24-24 lists the DC characteristics. Table 24-25 lists the permissible output currents.

Table 24-24 DC Characteristics

Conditions: $V_{CC} = 4.5\text{ V to }5.5\text{ V}$, $PWMV_{CC} = 4.5\text{ V to }5.5\text{ V}$, $AV_{CC} = 4.5\text{ V to }5.5\text{ V}$,
 $V_{ref} = 4.5\text{ V to }AV_{CC}$, $V_{SS} = PWMV_{SS} = PLLV_{SS} = AV_{SS} = 0\text{ V}$, $T_a = -20^\circ\text{C to }+75^\circ\text{C}$
 (regular specifications), $T_a = -40^\circ\text{C to }+85^\circ\text{C}$ (wide-range specifications)*1 *5

Item	Symbol	Min.	Typ.	Max.	Unit	Test Conditions
Schmitt trigger input voltage	IRQ0 to IRQ5	V_T^-	1.0	—	—	V
		V_T^+	—	—	$V_{CC} \times 0.7$	
		$V_T^+ - V_T^-$	0.4	—	—	
Input high voltage	\overline{RES} , \overline{STBY} , NMI, FWE, MD2 to MD0	V_{IH}	$V_{CC} - 0.7$	—	$V_{CC} + 0.3$	V
	EXTAL		$V_{CC} \times 0.7$	—	$V_{CC} + 0.3$	
	Ports 1, 3, F		2.2	—	$V_{CC} + 0.3$	
	Ports A to E		$V_{CC} \times 0.8$	—	$V_{CC} + 0.3$	
	Ports H, J		$PWMV_{CC} \times 0.8$	—	$PWMV_{CC} + 0.3$	
	HRxD0, HRxD1*7		2.2	—	$V_{CC} + 0.3$	
	Ports 4 and 9		$AV_{CC} \times 0.7$	—	$AV_{CC} + 0.3$	
Input low voltage	\overline{RES} , \overline{STBY} , NMI, FWE, MD2 to MD0	V_{IL}	-0.3	—	0.5	V
	EXTAL		-0.3	—	0.8	
	Ports 1, 3, F		-0.3	—	0.8	
	Ports A to E		-0.3	—	$V_{CC} \times 0.2$	
	Ports H, J		-0.3	—	$PWMV_{CC} \times 0.2$	
	HRxD0, HRxD1*7		-0.3	—	$V_{CC} \times 0.2$	
	Ports 4, 9		-0.3	—	$AV_{CC} \times 0.2$	

Item	Symbol	Min.	Typ.	Max.	Unit	Test Conditions	
Output high voltage	Ports 1, 3, A to F, H, J HTxD0, HTxD1 ^{*7} (excluding P34 and P35 ^{*6})	V_{OH}	$V_{CC} - 0.5$	—	—	V	$I_{OH} = -200 \mu A$
	P34, P35 ^{*6}		$V_{CC} - 2.5$	—	—		$I_{OH} = -100 \mu A$
	Ports 1, 3, A to F, H, J HTxD0, HTxD1 ^{*7} (excluding P34 and P35 ^{*6})		3.5	—	—		$I_{OH} = -1 \text{ mA}$
	PWM1A to PWM1H, PWM2A to PWM2H		$PWMV_{CC} - 0.5$	—	—		$I_{OH} = -15 \text{ mA}$
Output low voltage	All output pins except PWM1A to PWM1H, PWM2A to PWM2H	V_{OL}	—	—	0.4	V	$I_{OL} = 1.6 \text{ mA}$
	PWM1A to PWM1H, PWM2A to PWM2H		—	—	0.5	V	$I_{OL} = 15 \text{ mA}$
Input leakage current	\overline{RES}	$ I_{in} $	—	—	1.0	μA	$V_{in} = 0.5 \text{ V to } V_{CC} - 0.5 \text{ V}$
	STBY, NMI, MD2 to MD0		—	—	1.0		
	HRxD0, HRxD1 ^{*7} , FWE		—	—	1.0		
	Ports 4, 9		—	—	1.0		$V_{in} = 0.5 \text{ V to } AV_{CC} - 0.5 \text{ V}$
Three-state leakage current (off state)	Ports 1, 3, A to F, H, J HTxD0, HTxD1 ^{*7}	$ I_{TSI} $	—	—	1.0	μA	$V_{in} = 0.5 \text{ V to } V_{CC} - 0.5 \text{ V}$

Item		Symbol	Min.	Typ.	Max.	Unit	Test Conditions
MOS input pull-up current	Ports A to E	$-I_P$	50	—	300	μA	$V_{in} = 0\text{ V}$
Input capacitance	$\overline{\text{RES}}$	C_{in}	—	—	30	pF	$V_{in} = 0\text{ V}$
	NMI		—	—	30		$f = 1\text{ MHz}$
	All input pins except $\overline{\text{RES}}$ and NMI		—	—	15		$T_a = 25^\circ\text{C}$
Current dissipation*2 (H8S/2639 Group)	Normal operation	I_{CC}^{*4}	—	75	90	mA	$f = 20\text{ MHz}$
	Sleep mode		—	65	80		
	All modules stopped		—	57	—	mA	$f = 20\text{ MHz}$ (reference value)
	Medium-speed mode ($\phi/32$)		—	49	—		
	Subactive mode		—	0.7	1.0	mA	Subclock (using 4.19 MHz crystal oscillator)
	Subsleep mode		—	0.7	1.0		
	Watch mode		—	0.6	1.0		
	Standby mode*3		—	2.0	5.0	μA	$T_a \leq 50^\circ\text{C}$
		—	—	20		$50^\circ\text{C} < T_a$	
Current dissipation*2 (H8S/2635 Group)	Normal operation	I_{CC}^{*8}	—	60	65	mA	$f = 20\text{ MHz}$
	Sleep mode		—	50	55		
	All modules stopped		—	40	—	mA	$f = 20\text{ MHz}$ (reference value)
	Medium-speed mode ($\phi/32$)		—	45	—		
	Subactive mode		—	0.35	0.4	mA	Subclock (using 5.0 MHz crystal oscillator)
	Subsleep mode		—	0.3	0.35		
	Watch mode		—	0.25	0.3		
	Standby mode		—	2.0	5.0	μA	$T_a \leq 50^\circ\text{C}$
		—	—	20		$50^\circ\text{C} < T_a$	

Item		Symbol	Min.	Typ.	Max.	Unit	Test Conditions
Analog power supply current	During A/D and D/A ^{*7} conversion	I_{CC}	—	1.0	2.0	mA	$AV_{CC} = 5.0\text{ V}$
	Idle		—	0.1	5.0	μA	
Reference current	During A/D and D/A ^{*7} conversion	I_{CC}	—	4.0	5.0	mA	$V_{ref} = 5.0\text{ V}$
	Idle		—	0.1	5.0	μA	
RAM standby voltage		V_{RAM}	2.0	—	—	V	

- Notes:
- If the A/D and D/A converters are not used, do not leave the AV_{CC} , V_{ref} , and AV_{SS} pins open. Apply a voltage between 4.5 V and 5.5 V to the AV_{CC} and V_{ref} pins by connecting them to V_{CC} , for instance. Set $V_{ref} \leq AV_{CC}$.
 - Current dissipation values are for $V_{IH}(\text{min.}) = V_{CC} - 0.5\text{ V}$, $V_{IL}(\text{max.}) = 0.5\text{ V}$ with all output pins unloaded and the on-chip pull-up resistors in the off state.
 - The values are for $V_{RAM} \leq V_{CC} < 3.0\text{ V}$, $V_{IH}(\text{min.}) = V_{CC} \times 0.9$, and $V_{IL}(\text{max.}) = 0.3\text{ V}$.
 - I_{CC} depends on V_{CC} and f as follows:
 $I_{CC}(\text{max.}) = 30\text{ (mA)} + 0.54\text{ (mA/(MHz} \times \text{V))} \times V_{CC} \times f$ (normal operation)
 $I_{CC}(\text{max.}) = 30\text{ (mA)} + 0.45\text{ (mA/(MHz} \times \text{V))} \times V_{CC} \times f$ (sleep mode)
 - If the motor-control PWM timer is not used, do not leave the $PMWV_{CC}$, or $PMWV_{SS}$ pins open. If the motor-control PWM timer is not used, apply a voltage of between 4.5 and 5.5 V to the $PMWV_{CC}$ pin, for instance, by connecting it to V_{CC} .
 - The characteristics of pins 34 and 35 apply to the W-mask version.
 - The HTxD1, HRxD1 pins, and D/A converter are not available in the H8S/2635 Group.
 - I_{CC} depends on V_{CC} and f as follows:
 $I_{CC}(\text{max.}) = 17\text{ (mA)} + 0.43\text{ (mA/(MHz} \times \text{V))} \times V_{CC} \times f$ (normal operation)
 $I_{CC}(\text{max.}) = 17\text{ (mA)} + 0.34\text{ (mA/(MHz} \times \text{V))} \times V_{CC} \times f$ (sleep mode)

Table 24-25 Permissible Output Currents

Conditions: $V_{CC} = 4.5\text{ V to }5.5\text{ V}$, $PWMV_{CC} = 4.5\text{ V to }5.5\text{ V}$, $AV_{CC} = 4.5\text{ V to }5.5\text{ V}$,
 $V_{ref} = 4.5\text{ V to }AV_{CC}$, $V_{SS} = PWMV_{SS} = PLLV_{SS} = AV_{SS} = 0\text{ V}$, $T_a = -20^\circ\text{C to }+75^\circ\text{C}$
 (regular specifications), $T_a = -40^\circ\text{C to }+85^\circ\text{C}$ (wide-range specifications)

Item		Symbol	Min.	Typ.	Max.	Unit	Test condition				
Permissible output low current (per pin)	All output pins except PWM1A to PWM1H, PWM2A to PWM2H	I_{OL}	—	—	10	mA					
	PWM1A to PWM1H, PWM2A to PWM2H	I_{OL}	—	—	25	mA	$T_a = 85^\circ\text{C}$				
							—	—	30	mA	$T_a = 25^\circ\text{C}$
							—	—	40	mA	$T_a = -40^\circ\text{C}$
Permissible output low current (total)	Total of all output pins excepting PWM1A to PWM1H, and PWM2A to PWM2H	ΣI_{OL}	—	—	80	mA					
	Total of PWM1A to PWM1H, and PWM2A to PWM2H	ΣI_{OL}	—	—	150	mA	$T_a = 85^\circ\text{C}$				
							—	—	180	mA	$T_a = 25^\circ\text{C}$
							—	—	220	mA	$T_a = -40^\circ\text{C}$
Permissible output high current (per pin)	All output pins except PWM1A to PWM1H, PWM2A to PWM2H	$-I_{OH}$	—	—	2.0	mA					
	PWM1A to PWM1H, PWM2A to PWM2H	$-I_{OH}$	—	—	25	mA	$T_a = 85^\circ\text{C}$				
							—	—	30	mA	$T_a = 25^\circ\text{C}$
							—	—	40	mA	$T_a = -40^\circ\text{C}$
Permissible output high current (total)	Total of all output pins excepting PWM1A to PWM1H, and PWM2A to PWM2H	$-\Sigma I_{OH}$	—	—	40	mA					
	Total of PWM1A to PWM1H, and PWM2A to PWM2H	$-\Sigma I_{OH}$	—	—	150	mA	$T_a = 85^\circ\text{C}$				
							—	—	180	mA	$T_a = 25^\circ\text{C}$
							—	—	220	mA	$T_a = -40^\circ\text{C}$

Note: To protect chip reliability, do not exceed the output current values in table 24-25.

Table 24-26 Bus Drive Characteristics [Option]*

Conditions: $V_{CC} = 4.5\text{ V to }5.5\text{ V}$, $PWMV_{CC} = 4.5\text{ V to }5.5\text{ V}$, $AV_{CC} = 4.5\text{ V to }5.5\text{ V}$,
 $V_{ref} = 4.5\text{ V to }AV_{CC}$, $V_{SS} = PWMV_{SS} = PLLV_{SS} = AV_{SS} = 0\text{ V}$, $T_a = -20^\circ\text{C to }+75^\circ\text{C}$
 (regular specifications), $T_a = -40^\circ\text{C to }+85^\circ\text{C}$ (wide-range specifications)

Applicable Pins: SCL1 to 0, SDA1 to 0

Item	Symbol	Min.	Typ.	Max.	Unit	Test Conditions
Schmitt trigger input voltage	V_T^-	1.0	—	—	V	
	V_T^+	—	—	$V_{CC} \times 0.7$		
	$V_T^+ - V_T^-$	0.4	—	—		$V_{CC} = 4.5\text{ V to }5.5\text{ V}$
Input high voltage	V_{IH}	$-V_{CC} \times 0.7$	—	$V_{CC} + 0.5$	V	
Input low voltage	V_{IL}	-0.5	—	$V_{CC} \times 0.3$	V	
Output low voltage	V_{OL}	—	—	0.7	V	$I_{OL} = 8\text{ mA}$, $V_{CC} = 4.5\text{ V to }5.5\text{ V}$
		—	—	0.4		$I_{OL} = 3\text{ mA}$, $V_{CC} = 4.5\text{ V to }5.5\text{ V}$
		—	—	0.4		$I_{OL} = 1.6\text{ mA}$, $V_{CC} = 3.3\text{ V to }5.5\text{ V}$
Input capacitance	C_{in}	—	—	20	pF	$V_{in} = 0\text{ V}$, $f = 1\text{ MHz}$, $T_a = 25^\circ\text{C}$
Three-state leakage current (off state)	$ I_{TSI} $	—	—	1.0	μA	$V_{in} = 0.5\text{ V to }V_{CC}$ -5.5 V
SCL, SDA, output fall time	t_{of}	$20 + 0.1Cb$	—	250	ns	

Note: * Available when using the I²C bus interface (the W-mask version only).

24.3.4 AC Characteristics

Figure 24-6 show, the test conditions for the AC characteristics.

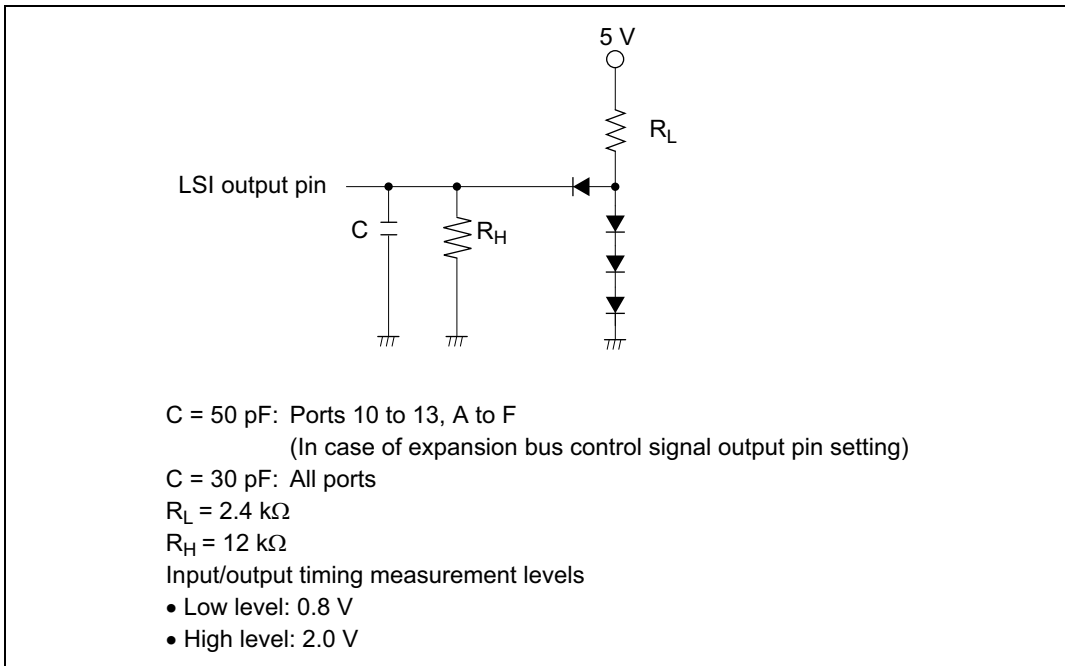

Figure 24-6 Output Load Circuit

(1) Clock Timing

Table 24-27 lists the clock timing

Table 24-27 Clock Timing

Conditions: $V_{CC} = 4.5\text{ V to }5.5\text{ V}$, $PWMV_{CC} = 4.5\text{ V to }5.5\text{ V}$, $AV_{CC} = 4.5\text{ V to }5.5\text{ V}$,
 $V_{ref} = 4.5\text{ V to }AV_{CC}$, $V_{SS} = PWMV_{SS} = PLLV_{SS} = AV_{SS} = 0\text{ V}$,
 $T_a = -20^{\circ}\text{C to }+75^{\circ}\text{C}$ (regular specifications), $T_a = -40^{\circ}\text{C to }+85^{\circ}\text{C}$ (wide-range specifications)

Item	Symbol	Condition		Unit	Test Conditions
		20MHz			
		Min.	Max.		
Clock cycle time	t_{cyc}	50	250	ns	Figure 24-9
Clock high pulse width	t_{CH}	15	—	ns	
Clock low pulse width	t_{CL}	15	—	ns	
Clock rise time	t_{Cr}	—	10	ns	
Clock fall time	t_{Cf}	—	10	ns	
Clock oscillator settling time at reset (crystal)	t_{OSC1}	20	—	ms	Figure 24-10
Clock oscillator settling time in software standby (crystal) (H8S/2639 Group)	t_{OSC2}	8	—	ms	Figure 23A-3 Figure 23B-3
Clock oscillator settling time in software standby (crystal) (H8S/2635 Group)		12	—		
External clock output stabilization delay time	t_{DEXT}	2	—	ms	Figure 24-10
Subclock oscillator frequency	f_{SUB}	31.25	39.6	kHz	
Subclock (ϕ_{SUB}) cycle time	t_{SUB}	25.6	32.0	μs	

(2) Control Signal Timing

Table 24-28 lists the control signal timing.

Table 24-28 Control Signal Timing

Conditions: $V_{CC} = 4.5\text{ V to }5.5\text{ V}$, $PWMV_{CC} = 4.5\text{ V to }5.5\text{ V}$, $AV_{CC} = 4.5\text{ V to }5.5\text{ V}$,
 $V_{ref} = 4.5\text{ V to }AV_{CC}$, $V_{SS} = PWMV_{SS} = PLLV_{SS} = AV_{SS} = 0\text{ V}$,
 $T_a = -20^\circ\text{C to }+75^\circ\text{C}$ (regular specifications), $T_a = -40^\circ\text{C to }+85^\circ\text{C}$ (wide-range specifications)

Item	Symbol	Condition		Unit	Test Conditions
		Min.	Max.		
$\overline{\text{RES}}$ setup time	t_{RESS}	200	—	ns	Figure 24-11
$\overline{\text{RES}}$ pulse width	t_{RESW}	20	—	t_{cyc}	
NMI setup time	t_{NMIS}	150	—	ns	Figure 24-12
NMI hold time	t_{NMIH}	10	—		
NMI pulse width (exiting software standby mode)	t_{NMIW}	200	—	ns	
$\overline{\text{IRQ}}$ setup time	t_{IRQS}	150	—	ns	
$\overline{\text{IRQ}}$ hold time	t_{IRQH}	10	—	ns	
$\overline{\text{IRQ}}$ pulse width (exiting software standby mode)	t_{IRQW}	200	—	ns	

(3) Bus Timing

Table 24-29 lists the bus timing.

Table 24-29 Bus Timing

Conditions: $V_{CC} = 4.5\text{ V to }5.5\text{ V}$, $PWMV_{CC} = 4.5\text{ V to }5.5\text{ V}$, $AV_{CC} = 4.5\text{ V to }5.5\text{ V}$,
 $V_{ref} = 4.5\text{ V to }AV_{CC}$, $V_{SS} = PWMV_{SS} = PLLV_{SS} = AV_{SS} = 0\text{ V}$,
 $T_a = -20^\circ\text{C to }+75^\circ\text{C}$ (regular specifications), $T_a = -40^\circ\text{C to }+85^\circ\text{C}$ (wide-range specifications)

Item	Symbol	Condition		Unit	Test Conditions
		Min.	Max.		
Address delay time	t_{AD}	—	35	ns	Figure 24-13 to Figure 24-17
Address setup time	t_{AS}	$0.5 \times t_{cyc} - 20$	—	ns	
Address hold time	t_{AH}	$0.5 \times t_{cyc} - 15$	—	ns	
\overline{AS} delay time	t_{ASD}	—	20	ns	
\overline{RD} delay time 1	t_{RSD1}	—	20	ns	
\overline{RD} delay time 2	t_{RSD2}	—	20	ns	
Read data setup time	t_{RDS}	20	—	ns	
Read data hold time	t_{RDH}	0	—	ns	
Read data access time1	t_{ACC1}	—	$1.0 \times t_{cyc} - 48$	ns	
Read data access time2	t_{ACC2}	—	$1.5 \times t_{cyc} - 45$	ns	
Read data access time3	t_{ACC3}	—	$2.0 \times t_{cyc} - 45$	ns	
Read data access time 4	t_{ACC4}	—	$2.5 \times t_{cyc} - 45$	ns	
Read data access time 5	t_{ACC5}	—	$3.0 \times t_{cyc} - 50$	ns	
\overline{WR} delay time 1	t_{WRD1}	—	20	ns	
\overline{WR} delay time 2	t_{WRD2}	—	20	ns	
\overline{WR} pulse width 1	t_{WSW1}	$1.0 \times t_{cyc} - 20$	—	ns	
\overline{WR} pulse width 2	t_{WSW2}	$1.5 \times t_{cyc} - 20$	—	ns	
Write data delay time	t_{WDD}	—	30	ns	
Write data setup time	t_{WDS}	$0.5 \times t_{cyc} - 20$	—	ns	
Write data hold time	t_{WDH}	$0.5 \times t_{cyc} - 10$	—	ns	

(4) Timing of On-Chip Supporting Modules

Table 24-30 lists the timing of on-chip supporting modules.

Table 24-30 Timing of On-Chip Supporting Modules

Conditions: $V_{CC} = 4.5\text{ V to }5.5\text{ V}$, $PWMV_{CC} = 4.5\text{ V to }5.5\text{ V}$, $AV_{CC} = 4.5\text{ V to }5.5\text{ V}$,
 $V_{ref} = 4.5\text{ V to }AV_{CC}$, $V_{SS} = PWMV_{SS} = PLLV_{SS} = AV_{SS} = 0\text{ V}$,
 $T_a = -20^\circ\text{C to }+75^\circ\text{C}$ (regular specifications), $T_a = -40^\circ\text{C to }+85^\circ\text{C}$ (wide-range specifications)

Item	Symbol	Condition		Unit	Test Conditions		
		Min.	Max.				
I/O port	Output data delay time	t_{PWD}	—	50	ns	Figure 24-18	
	Output data delay time 2	t_{PWD2}	—	50		Figure 24-19	
	Input data setup time	t_{PRS}	30	—			
	Input data hold time	t_{PRH}	30	—			
PPG* ¹	Pulse output delay time	t_{POD}	—	50	ns	Figure 24-20	
TPU	Timer output delay time	t_{TOCD}	—	50	ns	Figure 24-21	
	Timer input setup time	t_{TICS}	30	—			
	Timer clock input setup time	t_{TCKS}	30	—	ns	Figure 24-22	
	Timer clock pulse width	Single edge	t_{TCKWH}	1.5	—	t_{cyc}	
Both edges		t_{TCKWL}	2.5	—			
PWM	Pulse output delay time	t_{MPWMOD}	—	50	ns	Figure 24-23	
SCI	Input clock cycle	Asynchronous	t_{Scyc}	4	—	t_{cyc}	Figure 24-24
		Synchronous		6	—		
	Input clock pulse width	t_{SCKW}	0.4	0.6	t_{Scyc}		
	Input clock rise time	t_{SCKr}	—	1.5	t_{cyc}		
	Input clock fall time	t_{SCKf}	—	1.5			
	Transmit data delay time	t_{TXD}	—	50	ns	Figure 24-25	
A/D converter	Receive data setup time (synchronous)	t_{RXS}	50	—			
	Receive data hold time (synchronous)	t_{RXH}	50	—			
A/D converter	Trigger input setup time	t_{TRGS}	50	—	ns	Figure 24-26	

Item	Symbol	Condition			Unit	Test Conditions
		Min.	Max.			
HCAN* ²	Transmit data delay time	t _{HTXD}	—	100	ns	Figure 24-27
	Receive data setup time	t _{HRXS}	100	—		
	Receive data hold time	t _{HRXH}	100	—		

Notes: 1. The PPG output is not available in the H8S2635 Group.

2. The HCAN input signal is asynchronous. However, its state is judged to have changed at the leading edge (two clock cycles) of the CK clock signal shown in figure 24-27. The HCAN output signal is also asynchronous. Its state changes based on the leading edge (two clock cycles) of the CK clock signal shown in figure 24-27.

Table 24-31 I²C Bus Timing [Option]*¹

Conditions: V_{CC} = 4.5 V to 5.5 V, PWMV_{CC} = 4.5 V to 5.5 V, AV_{CC} = 4.5 V to 5.5 V,
V_{ref} = 4.5 V to AV_{CC}, V_{SS} = PWMV_{SS} = PLLV_{SS} = AV_{SS} = 0 V,
φ = 5 MHz to maximum operating frequency, T_a = -20°C to +75°C
(regular specifications), T_a = -40°C to +85°C (wide-range specifications)

Item	Symbol	Condition			Unit	Notes
		Min.	Typ.	Max.		
SCL input cycle time	t _{SCL}	12t _{cyc}	—	—	ns	Figure 24-28
SCL input high pulse width	t _{SCLH}	3t _{cyc}	—	—	ns	
SCL input low pulse width	t _{SCLL}	5t _{cyc}	—	—	ns	
SCL, SDA input rise time	t _{Sr}	—	—	7.5t _{cyc} * ²	ns	
SCL, SDA input fall time	t _{Sf}	—	—	300	ns	
SCL, SDA input spike pulse elimination time	t _{SP}	—	—	1t _{cyc}	ns	
SDA input bus free time	t _{BUF}	5t _{cyc}	—	—	ns	
Start condition input hold time	t _{STAH}	3t _{cyc}	—	—	ns	
Retransmission start condition input setup time	t _{STAS}	3t _{cyc}	—	—	ns	
Stop condition input setup time	t _{STOS}	3t _{cyc}	—	—	ns	
Data input setup time	t _{SDAS}	0.5t _{cyc}	—	—	ns	
Data input hold time	t _{SDAH}	0	—	—	ns	
SCL, SDA capacitive load	C _b	—	—	400	pF	

Notes: 1. Available when using I²C bus interface (the W-mask version only).

2. 17.5t_{cyc} can be set according to the clock selected for use by the I²C module. For details, see section 15.4, Usage Notes.

24.3.5 A/D Conversion Characteristics

Table 24-32 lists the A/D conversion characteristics.

Table 24-32 A/D Conversion Characteristics

Conditions: $V_{CC} = 4.5\text{ V to }5.5\text{ V}$, $PWMV_{CC} = 4.5\text{ V to }5.5\text{ V}$, $AV_{CC} = 4.5\text{ V to }5.5\text{ V}$,
 $V_{ref} = 4.5\text{ V to }AV_{CC}$, $V_{SS} = PWMV_{SS} = PLLV_{SS} = AV_{SS} = 0\text{ V}$,
 $T_a = -20^\circ\text{C to }+75^\circ\text{C}$ (regular specifications), $T_a = -40^\circ\text{C to }+85^\circ\text{C}$ (wide-range specifications)

Item	Condition			Unit
	Min.	Typ.	Max.	
Resolution	10	10	10	bits
Conversion time	10	—	—	μs
Analog input capacitance	—	—	20	pF
Permissible signal-source impedance	—	—	5	k Ω
Nonlinearity error	—	—	± 3.5	LSB
Offset error	—	—	± 3.5	LSB
Full-scale error	—	—	± 3.5	LSB
Quantization	—	± 0.5	—	LSB
Absolute accuracy	—	—	± 4.0	LSB

24.3.6 D/A Conversion Characteristics*

Table 24-33 shows the D/A conversion characteristics.

Note: * The D/A conversion is not implemented in the H8S/2635 and H8S/2634.

Table 24-33 D/A Conversion Characteristics

Conditions: $V_{CC} = 4.5\text{ V to }5.5\text{ V}$, $PWMV_{CC} = 4.5\text{ V to }5.5\text{ V}$, $AV_{CC} = 4.5\text{ V to }5.5\text{ V}$,
 $V_{ref} = 4.5\text{ V to }AV_{CC}$, $V_{SS} = PWMV_{SS} = PLLV_{SS} = AV_{SS} = 0\text{ V}$,
 $T_a = -20^\circ\text{C to }+75^\circ\text{C}$ (regular specifications), $T_a = -40^\circ\text{C to }+85^\circ\text{C}$ (wide-range specifications)

Item	Condition			Unit	Test Conditions
	Min.	Typ.	Max.		
Resolution	8	8	8	bits	
Conversion time	—	—	10	μs	20-pF capacitive load
Absolute accuracy	—	± 1.5	± 2.0	LSB	2-M Ω resistive load
	—	—	± 1.5	LSB	4-M Ω resistive load

24.3.7 Flash Memory Characteristics

Table 24-34 shows the flash memory characteristics.

Table 24-34 Flash Memory Characteristics

Conditions: $V_{CC}=4.5\text{ V to }5.5\text{ V}$, $PWMV_{CC}=4.5\text{ V to }5.5\text{ V}$, $AV_{CC}=4.5\text{ V to }5.5\text{ V}$,
 $V_{ref}=4.5\text{ V to }AV_{CC}$, $V_{SS}=PWMV_{SS}=PLL_{V_{SS}}$, $AV_{SS}=0\text{ V}$
 $T_a=0\text{ to }+75^\circ\text{C}$ (Programming/erasing operating temperature range: regular specification)

Item	Symbol	Min.	Typ.	Max.	Unit	Test Condition	
Programming time ^{*1 *2 *4}	t_P	—	10	200	ms/ 128 bytes		
Erase time ^{*1 *3 *5}	t_E	—	100	1200	ms/block		
Reprogramming count	N_{WEC}	—	—	100	Times		
Programming	Wait time after SWE bit setting ^{*1}	t_{SSWE}	1	1	—	μs	
	Wait time after PSU bit setting ^{*1}	t_{SPSU}	50	50	—	μs	
	Wait time after P bit setting ^{*1 *4}	t_{SP30}	28	30	32	μs	Programming time wait
		t_{SP200}	198	200	202	μs	Programming time wait
		t_{SP10}	8	10	12	μs	Additional-programming time wait
	Wait time after P bit clear ^{*1}	t_{CP}	5	5	—	μs	
	Wait time after PSU bit clear ^{*1}	t_{CPSU}	5	5	—	μs	
	Wait time after PV bit setting ^{*1}	t_{SPV}	4	4	—	μs	
	Wait time after H'FF dummy write ^{*1}	t_{SPVR}	2	2	—	μs	
	Wait time after PV bit clear ^{*1}	t_{CPV}	2	2	—	μs	
Wait time after SWE bit clear ^{*1}	t_{CSWE}	100	100	—	μs		
Maximum programming count ^{*1 *4}	N	—	—	1000	Times		
Erase	Wait time after SWE bit setting ^{*1}	t_{SSWE}	1	1	—	μs	
	Wait time after ESU bit setting ^{*1}	t_{SESU}	100	100	—	μs	
	Wait time after E bit setting ^{*1 *5}	t_{SE}	10	10	100	ms	Erase time wait
	Wait time after E bit clear ^{*1}	t_{CE}	10	10	—	μs	
	Wait time after ESU bit clear ^{*1}	t_{CESU}	10	10	—	μs	
	Wait time after EV bit setting ^{*1}	t_{SEV}	20	20	—	μs	

Item		Symbol	Min.	Typ.	Max.	Unit	Test Condition
Erase	Wait time after H'FF dummy write*1	t_{sevr}	2	2	—	μs	
	Wait time after EV bit clear*1	t_{cev}	4	4	—	μs	
	Wait time after SWE bit clear*1	t_{cswe}	100	100	—	μs	
	Maximum erase count*1 *5	N	12	—	120	Times	

- Notes: 1. Make each time setting in accordance with the program/program-verify flowchart or erase/erase-verify flowchart.
2. Programming time per 128 bytes (Shows the total period for which the P-bit in the flash memory control register (FLMCR1) is set. It does not include the programming verification time)
3. Block erase time (Shows the total period for which the E-bit in FLMCR1 is set. It does not include the erase verification time)
4. To specify the maximum programming time value (t_p (max.)) in the 128-byte programming algorithm, set the max. value (1000) for the maximum programming count (N).

The wait time after P bit setting should be changed as follows according to the value of the programming counter (n).

Programming counter (n) = 1 to 6: $t_{sp30} = 30 \mu\text{s}$

Programming counter (n) = 7 to 1000: $t_{sp200} = 200 \mu\text{s}$

[In additional programming]

Programming counter (n)= 1 to 6: $t_{sp10} = 10 \mu\text{s}$

5. For the maximum erase time (t_E (max.)), the following relationship applies between the wait time after E bit setting (t_{se}) and the maximum erase count (N):

$$t_E \text{ (max.)} = \text{Wait time after E bit setting (} t_{se} \text{) } \times \text{ maximum erase count (N)}$$

To set the maximum erase time, the values of (t_{se}) and (N) should be set so as to satisfy the above formula.

Examples: When $t_{se} = 100$ [ms], N = 12 times

When $t_{se} = 10$ [ms], N = 120 times

24.4 H8S/2630 Group Electrical Characteristics

24.4.1 Absolute Maximum Ratings

Table 24-35 lists the absolute maximum ratings.

Table 24-35 Absolute Maximum Ratings

Item	Symbol	Value	Unit
Power supply voltage	V_{CC}	-0.3 to +7.0	V
Input voltage (OSC1, OSC2)	V_{in}	-0.3 +4.3	V
Input voltage (XTAL, EXTAL)	V_{in}	-0.3 to $V_{CC} + 0.3$	V
Input voltage (ports 4 and 9)	V_{in}	-0.3 to $AV_{CC} + 0.3$	V
Input voltage (ports H and J)	V_{in}	-0.3 to $PWMV_{CC} + 0.3$	V
Input voltage (except XTAL, EXTAL, OSC1, OSC2, ports 4, 9, H and J)	V_{in}	-0.3 to $V_{CC} + 0.3$	V
Reference voltage	V_{ref}	-0.3 to $AV_{CC} + 0.3$	V
Analog power supply voltage	AV_{CC}	-0.3 to +7.0	V
Analog input voltage	V_{AN}	-0.3 to $AV_{CC} + 0.3$	V
Operating temperature	T_{opr}	Regular specifications: -20 to +75	°C
		Wide-range specifications: -40 to +85	°C
Storage temperature	T_{stg}	-55 to +125	°C

Caution: Permanent damage to the chip may result if absolute maximum rating are exceeded.

24.4.2 Power Supply Voltage and Operating Frequency Range

Power supply voltage and operating frequency ranges (shaded areas) are shown in figure 24-7.

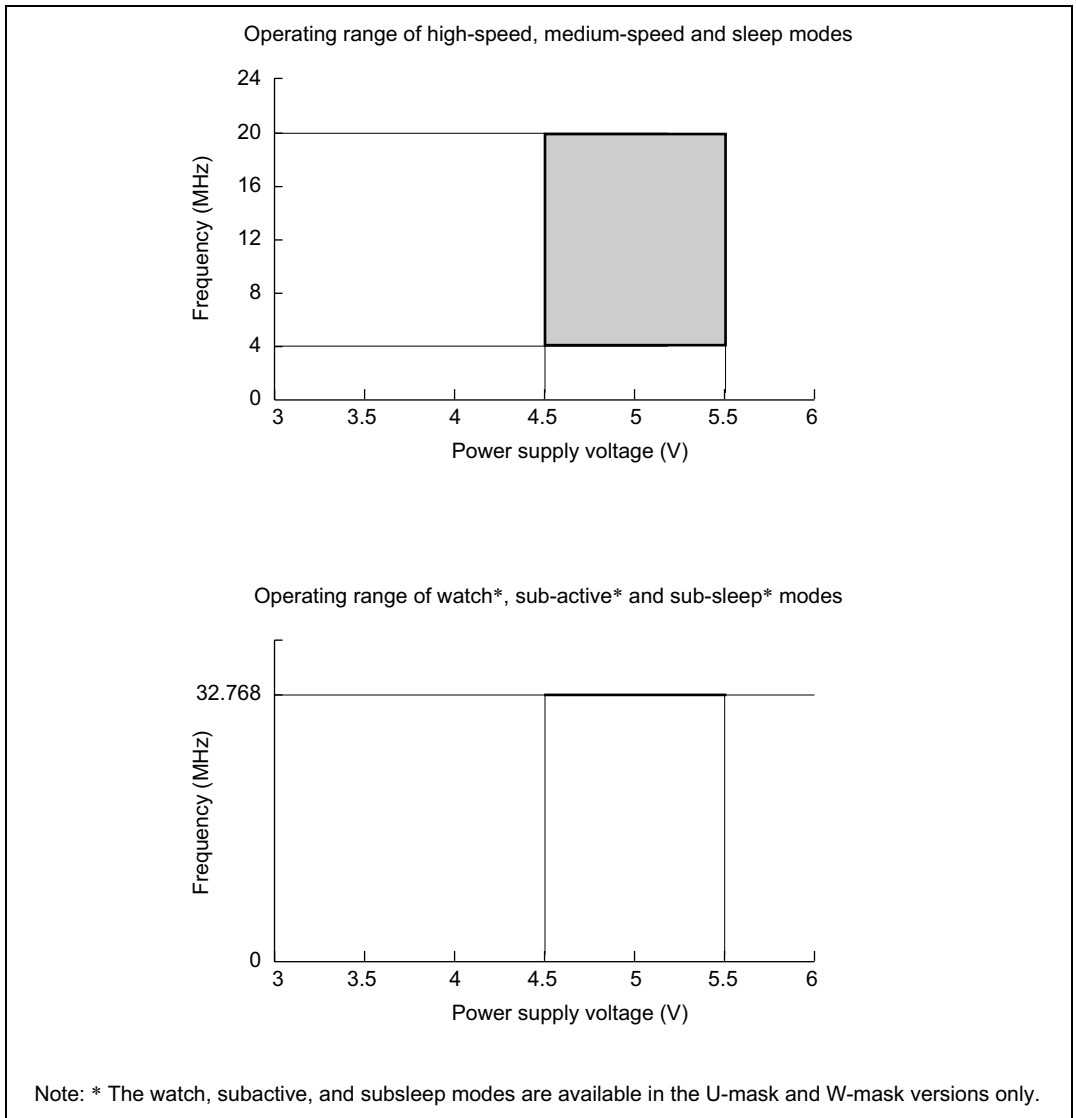

Figure 24-7 Power Supply Voltage and Operating Ranges

24.4.3 DC Characteristics

Table 24-36 lists the DC characteristics. Table 24-36 lists the permissible output currents.

Table 24-36 DC Characteristics

Conditions: $V_{CC} = 4.5\text{ V to }5.5\text{ V}$, $PWMV_{CC} = 4.5\text{ V to }5.5\text{ V}$, $AV_{CC} = 4.5\text{ V to }5.5\text{ V}$,
 $V_{ref} = 4.5\text{ V to }AV_{CC}$, $V_{SS} = PWMV_{SS} = PLLV_{SS} = AV_{SS} = 0\text{ V}$, $T_a = -20^\circ\text{C to }+75^\circ\text{C}$
 (regular specifications), $T_a = -40^\circ\text{C to }+85^\circ\text{C}$ (wide-range specifications)*1 *6

Item		Symbol	Min.	Typ.	Max.	Unit	Test Conditions
Schmitt trigger input voltage	IRQ0 to IRQ5	V_T^-	1.0	—	—	V	
		V_T^+	—	—	$V_{CC} \times 0.7$		
		$V_T^+ - V_T^-$	0.4	—	—		
Input high voltage	\overline{RES} , \overline{STBY} , NMI, FWE, MD2 to MD0	V_{IH}	$V_{CC} - 0.7$	—	$V_{CC} + 0.3$	V	
	EXTAL		$V_{CC} \times 0.7$	—	$V_{CC} + 0.3$		
	Ports 1, 3, F		2.2	—	$V_{CC} + 0.3$		
	Ports A to E		$V_{CC} \times 0.8$	—	$V_{CC} + 0.3$		
	Ports H, J		$PWMV_{CC} \times 0.8$	—	$PWMV_{CC} + 0.3$		
	HRxD0, HRxD1		2.2	—	$V_{CC} + 0.3$		
	Ports 4 and 9		$AV_{CC} \times 0.7$	—	$AV_{CC} + 0.3$		
Input low voltage	\overline{RES} , \overline{STBY} , NMI, FWE, MD2 to MD0	V_{IL}	-0.3	—	0.5	V	
	EXTAL		-0.3	—	0.8		
	Ports 1, 3, F		-0.3	—	0.8		
	Ports A to E		-0.3	—	$V_{CC} \times 0.2$		
	Ports H, J		-0.3	—	$PWMV_{CC} \times 0.2$		
	HRxD0, HRxD1		-0.3	—	$V_{CC} \times 0.2$		
	Ports 4, 9		-0.3	—	$AV_{CC} \times 0.2$		

Item	Symbol	Min.	Typ.	Max.	Unit	Test Conditions	
Output high voltage	Ports 1, 3, A to F, H, J HTxD0, HTxD1 (excluding P34 and P35 ^{*7})	V_{OH}	$V_{CC} - 0.5$	—	—	V	$I_{OH} = -200 \mu A$
	P34, P35 ^{*7}		$V_{CC} - 2.5$	—	—		$I_{OH} = -100 \mu A$
	Ports 1, 3, A to F, H, J HTxD0, HTxD1 (excluding P34 and P35 ^{*7})		3.5	—	—		$I_{OH} = -1 \text{ mA}$
	PWM1A to PWM1H, PWM2A to PWM2H		$PWMV_{CC} - 0.5$	—	—		$I_{OH} = -15 \text{ mA}$
Output low voltage	All output pins except PWM1A to PWM1H, PWM2A to PWM2H	V_{OL}	—	—	0.4	V	$I_{OL} = 1.6 \text{ mA}$
	PWM1A to PWM1H, PWM2A to PWM2H		—	—	0.5	V	$I_{OL} = 15 \text{ mA}$
Input leakage current	\overline{RES}	$ I_{in} $	—	—	1.0	μA	$V_{in} = 0.5 \text{ V to } V_{CC} - 0.5 \text{ V}$
	\overline{STBY} , \overline{NMI} , MD2 to MD0		—	—	1.0		
	HRxD0, HRxD1, FWE		—	—	1.0		
	Ports 4, 9		—	—	1.0		$V_{in} = 0.5 \text{ V to } AV_{CC} - 0.5 \text{ V}$
Three-state leakage current (off state)	Ports 1, 3, A to F, H, J HTxD0, HTxD1	$ I_{TSI} $	—	—	1.0	μA	$V_{in} = 0.5 \text{ V to } V_{CC} - 0.5 \text{ V}$

Item		Symbol	Min.	Typ.	Max.	Unit	Test Conditions
MOS input pull-up current	Ports A to E	$-I_P$	50	—	300	μA	$V_{in} = 0\text{ V}$
Input capacitance	$\overline{\text{RES}}$	C_{in}	—	—	30	pF	$V_{in} = 0\text{ V}$
	NMI		—	—	30		$f = 1\text{ MHz}$
	All input pins except $\overline{\text{RES}}$ and NMI		—	—	15		$T_a = 25^\circ\text{C}$
Current dissipation*2	Normal operation	I_{CC}^{*4}	—	75	90	mA	$f = 20\text{ MHz}$
	Sleep mode		—	65	80		
	All modules stopped		—	57	—	mA	$f = 20\text{ MHz}$ (reference value)
	Medium-speed mode ($\phi/32$)		—	49	—		
	Subactive mode*5		—	130	220	μA	Using 32.768 kHz crystal resonator
	Subsleep mode*5		—	80	160		
	Watch mode*5		—	30	60		
	Standby mode*3		—	2.0	5.0	μA	$T_a \leq 50^\circ\text{C}$ $50^\circ\text{C} < T_a$
Analog power supply current	During A/D and D/A conversion	I_{CC}	—	1.0	2.0	mA	$AV_{CC} = 5.0\text{ V}$
	Idle		—	0.1	5.0	μA	
Reference current	During A/D and D/A conversion	I_{CC}	—	4.0	5.0	mA	$V_{ref} = 5.0\text{ V}$
	Idle		—	0.1	5.0	μA	
RAM standby voltage		V_{RAM}	2.0	—	—	V	

Notes: 1. If the A/D and D/A converters are not used, do not leave the AV_{CC} , V_{ref} , and AV_{SS} pins open. Apply a voltage between 4.5 V and 5.5 V to the AV_{CC} and V_{ref} pins by connecting them to V_{CC} , for instance. Set $V_{ref} \leq AV_{CC}$.

2. Current dissipation values are for $V_{IH}(\text{min.}) = V_{CC} - 0.5\text{ V}$, $V_{IL}(\text{max.}) = 0.5\text{ V}$ with all output pins unloaded and the on-chip pull-up resistors in the off state.

3. The values are for $V_{RAM} \leq V_{CC} < 3.0\text{ V}$, $V_{IH}(\text{min.}) = V_{CC} \times 0.9$, and $V_{IL}(\text{max.}) = 0.3\text{ V}$.

4. I_{CC} depends on V_{CC} and f as follows:

$$I_{CC} (\text{max.}) = 30 (\text{mA}) + 0.54 (\text{mA}/(\text{MHz} \times \text{V})) \times V_{CC} \times f (\text{normal operation})$$

$$I_{CC} (\text{max.}) = 30 (\text{mA}) + 0.45 (\text{mA}/(\text{MHz} \times \text{V})) \times V_{CC} \times f (\text{sleep mode})$$

5. The watch, subactive, and subsleep modes are available in the U-mask and W-mask versions only.

See section 22A.7, Subclock Oscillator, for the method of fixing pins OSC1 and OSC2.

6. If the motor-control PWM timer is not used, do not leave the $PMWV_{CC}$, or $PMWV_{SS}$ pins open. If the motor-control PWM timer is not used, apply a voltage of between 4.5 and 5.5 V to the $PMWV_{CC}$ pin, for instance, by connecting it to V_{CC} .
7. The characteristics of pins 34 and 35 apply to the W-mask version.

Table 24-37 Permissible Output Currents

Conditions: $V_{CC} = 4.5 \text{ V to } 5.5 \text{ V}$, $PWMV_{CC} = 4.5 \text{ V to } 5.5 \text{ V}$, $AV_{CC} = 4.5 \text{ V to } 5.5 \text{ V}$,
 $V_{ref} = 4.5 \text{ V to } AV_{CC}$, $V_{SS} = PWMV_{SS} = PLLV_{SS} = AV_{SS} = 0 \text{ V}$, $T_a = -20^\circ\text{C to } +75^\circ\text{C}$
 (regular specifications), $T_a = -40^\circ\text{C to } +85^\circ\text{C}$ (wide-range specifications)

Item		Symbol	Min.	Typ.	Max.	Unit	Test condition
Permissible output low current (per pin)	All output pins except PWM1A to PWM1H, PWM2A to PWM2H	I_{OL}	—	—	10	mA	
	PWM1A to PWM1H, PWM2A to PWM2H	I_{OL}	—	—	25	mA	$T_a = 85^\circ\text{C}$
					30		$T_a = 25^\circ\text{C}$
		—	—	40	mA	$T_a = -40^\circ\text{C}$	
Permissible output low current (total)	Total of all output pins excepting PWM1A to PWM1H, and PWM2A to PWM2H	ΣI_{OL}	—	—	80	mA	
	Total of PWM1A to PWM1H, and PWM2A to PWM2H	ΣI_{OL}	—	—	150	mA	$T_a = 85^\circ\text{C}$
					180		$T_a = 25^\circ\text{C}$
		—	—	220	mA	$T_a = -40^\circ\text{C}$	
Permissible output high current (per pin)	All output pins except PWM1A to PWM1H, PWM2A to PWM2H	$-I_{OH}$	—	—	2.0	mA	
	PWM1A to PWM1H, PWM2A to PWM2H	$-I_{OH}$	—	—	25	mA	$T_a = 85^\circ\text{C}$
					30		$T_a = 25^\circ\text{C}$
		—	—	40	mA	$T_a = -40^\circ\text{C}$	
Permissible output high current (total)	Total of all output pins excepting PWM1A to PWM1H, and PWM2A to PWM2H	$-\Sigma I_{OH}$	—	—	40	mA	
	Total of PWM1A to PWM1H, and PWM2A to PWM2H	$-\Sigma I_{OH}$	—	—	150	mA	$T_a = 85^\circ\text{C}$
					180		$T_a = 25^\circ\text{C}$
		—	—	220	mA	$T_a = -40^\circ\text{C}$	

Note: To protect chip reliability, do not exceed the output current values in table 24-37.

Table 24-38 Bus Drive Characteristics [Option]*

Conditions: $V_{CC} = 4.5\text{ V to }5.5\text{ V}$, $PWMV_{CC} = 4.5\text{ V to }5.5\text{ V}$, $AV_{CC} = 4.5\text{ V to }5.5\text{ V}$,
 $V_{ref} = 4.5\text{ V to }AV_{CC}$, $V_{SS} = PWMV_{SS} = PLLV_{SS} = AV_{SS} = 0\text{ V}$, $T_a = -20^\circ\text{C to }+75^\circ\text{C}$
 (regular specifications), $T_a = -40^\circ\text{C to }+85^\circ\text{C}$ (wide-range specifications)

Applicable Pins: SCL1-0, SDA1-0

Item	Symbol	Min.	Typ.	Max.	Unit	Test Conditions
Schmitt trigger input voltage	V_{T^-}	1.0	—	—	V	
	V_{T^+}	—	—	$V_{CC} \times 0.7$		
	$V_{T^+} - V_{T^-}$	0.4	—	—		$V_{CC} = 4.5\text{ V to }5.5\text{ V}$
Input high voltage	V_{IH}	$-V_{CC} \times 0.7$	—	$V_{CC} + 0.5$	V	
Input low voltage	V_{IL}	-0.5	—	$V_{CC} \times 0.3$	V	
Output low voltage	V_{OL}	—	—	0.7	V	$I_{OL} = 8\text{ mA}$, $V_{CC} = 4.5\text{ V to }5.5\text{ V}$
		—	—	0.4		$I_{OL} = 3\text{ mA}$, $V_{CC} = 4.5\text{ V to }5.5\text{ V}$
		—	—	0.4		$I_{OL} = 1.6\text{ mA}$, $V_{CC} = 3.3\text{ V to }5.5\text{ V}$
Input capacitance	C_{in}	—	—	20	pF	$V_{in} = 0\text{ V}$, $f = 1\text{ MHz}$, $T_a = 25^\circ\text{C}$
Three-state leakage current (off state)	$ I_{TSL} $	—	—	1.0	μA	$V_{in} = 0.5\text{ V to }V_{CC}$ -5.5 V
SCL, SDA, output fall time	t_{of}	$20 + 0.1Cb$	—	250	ns	

Note: * Available when using I²C bus interface (the W-mask version only).

24.4.4 AC Characteristics

Figure 24-8 show, the test conditions for the AC characteristics.

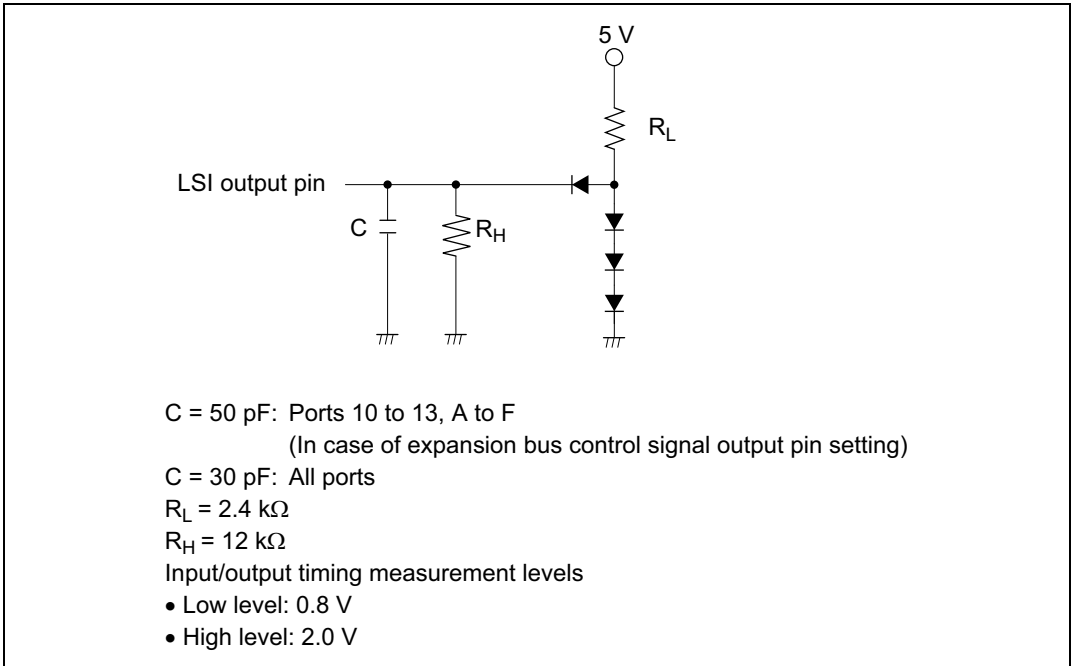

Figure 24-8 Output Load Circuit

(1) Clock Timing

Table 24-39 lists the clock timing

Table 24-39 Clock Timing

Conditions: $V_{CC} = 4.5\text{ V to }5.5\text{ V}$, $PWMV_{CC} = 4.5\text{ V to }5.5\text{ V}$, $AV_{CC} = 4.5\text{ V to }5.5\text{ V}$,
 $V_{ref} = 4.5\text{ V to }AV_{CC}$, $V_{SS} = PWMV_{SS} = PLLV_{SS} = AV_{SS} = 0\text{ V}$,
 $T_a = -20^\circ\text{C to }+75^\circ\text{C}$ (regular specifications), $T_a = -40^\circ\text{C to }+85^\circ\text{C}$ (wide-range specifications)

Item	Symbol	Condition		Unit	Test Conditions
		20MHz			
		Min.	Max.		
Clock cycle time	t_{cyc}	50	250	ns	Figure 24-9
Clock high pulse width	t_{CH}	15	—	ns	
Clock low pulse width	t_{CL}	15	—	ns	
Clock rise time	t_{Cr}	—	10	ns	
Clock fall time	t_{Cf}	—	10	ns	
Clock oscillator settling time at reset (crystal)	t_{OSC1}	20	—	ms	Figure 24-10
Clock oscillator settling time in software standby (crystal)	t_{OSC2}	8	—	ms	Figure 23A-3 Figure 23B-3
External clock output stabilization delay time	t_{DEXT}	2	—	ms	Figure 24-10
32-kHz clock oscillation settling time	t_{OSC3}	—	2	s	
Subclock oscillator frequency	f_{SUB}	32.768		kHz	
Subclock (ϕ_{SUB}) cycle time	t_{SUB}	30.5		μs	

(2) Control Signal Timing

Table 24-40 lists the control signal timing.

Table 24-40 Control Signal Timing

Conditions: $V_{CC} = 4.5\text{ V to }5.5\text{ V}$, $PWMV_{CC} = 4.5\text{ V to }5.5\text{ V}$, $AV_{CC} = 4.5\text{ V to }5.5\text{ V}$,
 $V_{ref} = 4.5\text{ V to }AV_{CC}$, $V_{SS} = PWMV_{SS} = PLLV_{SS} = AV_{SS} = 0\text{ V}$,
 $T_a = -20^\circ\text{C to }+75^\circ\text{C}$ (regular specifications), $T_a = -40^\circ\text{C to }+85^\circ\text{C}$ (wide-range specifications)

Item	Symbol	Condition		Unit	Test Conditions
		Min.	Max.		
\overline{RES} setup time	t_{RESS}	200	—	ns	Figure 24-11
\overline{RES} pulse width	t_{RESW}	20	—	t_{cyc}	
NMI setup time	t_{NMIS}	150	—	ns	Figure 24-12
NMI hold time	t_{NMIH}	10	—		
NMI pulse width (exiting software standby mode)	t_{NMIW}	200	—	ns	
\overline{IRQ} setup time	t_{IRQS}	150	—	ns	
\overline{IRQ} hold time	t_{IRQH}	10	—	ns	
\overline{IRQ} pulse width (exiting software standby mode)	t_{IRQW}	200	—	ns	

(3) Bus Timing

Table 24-41 lists the bus timing.

Table 24-41 Bus Timing

Conditions: $V_{CC} = 4.5\text{ V to }5.5\text{ V}$, $PWMV_{CC} = 4.5\text{ V to }5.5\text{ V}$, $AV_{CC} = 4.5\text{ V to }5.5\text{ V}$,
 $V_{ref} = 4.5\text{ V to }AV_{CC}$, $V_{SS} = PWMV_{SS} = PLLV_{SS} = AV_{SS} = 0\text{ V}$,
 $T_a = -20^{\circ}\text{C to }+75^{\circ}\text{C}$ (regular specifications), $T_a = -40^{\circ}\text{C to }+85^{\circ}\text{C}$ (wide-range specifications)

Item	Symbol	Condition		Unit	Test Conditions
		Min.	Max.		
Address delay time	t_{AD}	—	35	ns	Figure 24-13 to Figure 24-17
Address setup time	t_{AS}	$0.5 \times t_{cyc} - 20$	—	ns	
Address hold time	t_{AH}	$0.5 \times t_{cyc} - 15$	—	ns	
\overline{AS} delay time	t_{ASD}	—	20	ns	
\overline{RD} delay time 1	t_{RSD1}	—	20	ns	
\overline{RD} delay time 2	t_{RSD2}	—	20	ns	
Read data setup time	t_{RDS}	20	—	ns	
Read data hold time	t_{RDH}	0	—	ns	
Read data access time1	t_{ACC1}	—	$1.0 \times t_{cyc} - 48$	ns	
Read data access time2	t_{ACC2}	—	$1.5 \times t_{cyc} - 45$	ns	
Read data access time3	t_{ACC3}	—	$2.0 \times t_{cyc} - 45$	ns	
Read data access time 4	t_{ACC4}	—	$2.5 \times t_{cyc} - 45$	ns	
Read data access time 5	t_{ACC5}	—	$3.0 \times t_{cyc} - 50$	ns	
\overline{WR} delay time 1	t_{WRD1}	—	20	ns	
\overline{WR} delay time 2	t_{WRD2}	—	20	ns	
\overline{WR} pulse width 1	t_{WSW1}	$1.0 \times t_{cyc} - 20$	—	ns	
\overline{WR} pulse width 2	t_{WSW2}	$1.5 \times t_{cyc} - 20$	—	ns	
Write data delay time	t_{WDD}	—	30	ns	
Write data setup time	t_{WDS}	$0.5 \times t_{cyc} - 20$	—	ns	
Write data hold time	t_{WDH}	$0.5 \times t_{cyc} - 10$	—	ns	

(4) Timing of On-Chip Supporting Modules

Table 24-42 lists the timing of on-chip supporting modules.

Table 24-42 Timing of On-Chip Supporting Modules

Conditions: $V_{CC} = 4.5\text{ V to }5.5\text{ V}$, $PWMV_{CC} = 4.5\text{ V to }5.5\text{ V}$, $AV_{CC} = 4.5\text{ V to }5.5\text{ V}$,
 $V_{ref} = 4.5\text{ V to }AV_{CC}$, $V_{SS} = PWMV_{SS} = PLLV_{SS} = AV_{SS} = 0\text{ V}$,
 $T_a = -20^\circ\text{C to }+75^\circ\text{C}$ (regular specifications), $T_a = -40^\circ\text{C to }+85^\circ\text{C}$ (wide-range specifications)

Item	Symbol	Condition		Unit	Test Conditions		
		Min.	Max.				
I/O port	Output data delay time	t_{PWD}	—	50	ns	Figure 24-18	
	Output data delay time 2	t_{PWD2}	—	50		Figure 24-19	
	Input data setup time	t_{PRS}	30	—			
	Input data hold time	t_{PRH}	30	—			
PPG	Pulse output delay time	t_{POD}	—	50	ns	Figure 24-20	
TPU	Timer output delay time	t_{TOCD}	—	50	ns	Figure 24-21	
	Timer input setup time	t_{TICS}	30	—			
	Timer clock input setup time	t_{TCKS}	30	—	ns	Figure 24-22	
	Timer clock pulse width	Single edge	t_{TCKWH}	1.5	—	t_{cyc}	
Both edges		t_{TCKWL}	2.5	—			
PWM	Pulse output delay time	t_{MPWMOD}	—	50	ns	Figure 24-23	
SCI	Input clock cycle	Asynchronous	t_{Scyc}	4	—	t_{cyc}	Figure 24-24
		Synchronous		6	—		
	Input clock pulse width	t_{SCKW}	0.4	0.6	t_{Scyc}		
	Input clock rise time	t_{SCKr}	—	1.5	t_{cyc}		
	Input clock fall time	t_{SCKf}	—	1.5			
	Transmit data delay time	t_{TXD}	—	50	ns	Figure 24-25	
	Receive data setup time (synchronous)	t_{RXS}	50	—			
Receive data hold time (synchronous)	t_{RXH}	50	—				
A/D converter	Trigger input setup time	t_{TRGS}	50	—	ns	Figure 24-26	

Item	Symbol	Condition		Unit	Test Conditions	
		Min.	Max.			
HCAN*	Transmit data delay time	t_{HTXD}	—	100	ns	Figure 24-27
	Receive data setup time	t_{HRXS}	100	—		
	Receive data hold time	t_{HRXH}	100	—		

Note: * The HCAN input signal is asynchronous. However, its state is judged to have changed at the leading edge (two clock cycles) of the CK clock signal shown in figure 24-27. The HCAN output signal is also asynchronous. Its state changes based on the leading edge (two clock cycles) of the CK clock signal shown in figure 24-27.

Table 24-43 I²C Bus Timing [Option]*¹

Conditions: $V_{CC} = 4.5\text{ V to }5.5\text{ V}$, $PWMV_{CC} = 4.5\text{ V to }5.5\text{ V}$, $AV_{CC} = 4.5\text{ V to }5.5\text{ V}$,
 $V_{ref} = 4.5\text{ V to }AV_{CC}$, $V_{SS} = PWMV_{SS} = PLLV_{SS} = AV_{SS} = 0\text{ V}$,
 $\phi = 5\text{ MHz to maximum operating frequency}$, $T_a = -20^\circ\text{C to }+75^\circ\text{C}$
(regular specifications), $T_a = -40^\circ\text{C to }+85^\circ\text{C}$ (wide-range specifications)

Item	Symbol	Condition			Unit	Notes
		Min.	Typ.	Max.		
SCL input cycle time	t_{SCL}	$12t_{cyc}$	—	—	ns	Figure 24-28
SCL input high pulse width	t_{SCLH}	$3t_{cyc}$	—	—	ns	
SCL input low pulse width	t_{SCLL}	$5t_{cyc}$	—	—	ns	
SCL, SDA input rise time	t_{Sr}	—	—	$7.5t_{cyc}^{*2}$	ns	
SCL, SDA input fall time	t_{Sf}	—	—	300	ns	
SCL, SDA input spike pulse elimination time	t_{SP}	—	—	$1t_{cyc}$	ns	
SDA input bus free time	t_{BUF}	$5t_{cyc}$	—	—	ns	
Start condition input hold time	t_{STAH}	$3t_{cyc}$	—	—	ns	
Retransmission start condition input setup time	t_{STAS}	$3t_{cyc}$	—	—	ns	
Stop condition input setup time	t_{STOS}	$3t_{cyc}$	—	—	ns	
Data input setup time	t_{SDAS}	$0.5t_{cyc}$	—	—	ns	
Data input hold time	t_{SDAH}	0	—	—	ns	
SCL, SDA capacitive load	C_b	—	—	400	pF	

Notes: 1. Available when using I²C bus interface (the W-mask version only).

2. $17.5t_{cyc}$ can be set according to the clock selected for use by the I²C module. For details, see section 15.4, Usage Notes.

24.4.5 A/D Conversion Characteristics

Table 24-44 lists the A/D conversion characteristics.

Table 24-44 A/D Conversion Characteristics

Conditions: $V_{CC} = 4.5\text{ V to }5.5\text{ V}$, $PWMV_{CC} = 4.5\text{ V to }5.5\text{ V}$, $AV_{CC} = 4.5\text{ V to }5.5\text{ V}$,
 $V_{ref} = 4.5\text{ V to }AV_{CC}$, $V_{SS} = PWMV_{SS} = PLLV_{SS} = AV_{SS} = 0\text{ V}$,
 $T_a = -20^\circ\text{C to }+75^\circ\text{C}$ (regular specifications), $T_a = -40^\circ\text{C to }+85^\circ\text{C}$ (wide-range specifications)

Item	Condition			Unit
	Min.	Typ.	Max.	
Resolution	10	10	10	bits
Conversion time	10	—	—	μs
Analog input capacitance	—	—	20	pF
Permissible signal-source impedance	—	—	5	k Ω
Nonlinearity error	—	—	± 3.5	LSB
Offset error	—	—	± 3.5	LSB
Full-scale error	—	—	± 3.5	LSB
Quantization	—	± 0.5	—	LSB
Absolute accuracy	—	—	± 4.0	LSB

24.4.6 D/A Conversion Characteristics

Table 24-45 shows the D/A conversion characteristics.

Table 24-45 D/A Conversion Characteristics

Conditions: $V_{CC} = 4.5\text{ V to }5.5\text{ V}$, $PWMV_{CC} = 4.5\text{ V to }5.5\text{ V}$, $AV_{CC} = 4.5\text{ V to }5.5\text{ V}$,
 $V_{ref} = 4.5\text{ V to }AV_{CC}$, $V_{SS} = PWMV_{SS} = PLLV_{SS} = AV_{SS} = 0\text{ V}$,
 $T_a = -20^\circ\text{C to }+75^\circ\text{C}$ (regular specifications), $T_a = -40^\circ\text{C to }+85^\circ\text{C}$ (wide-range specifications)

Item	Condition			Unit	Test Conditions
	Min.	Typ.	Max.		
Resolution	8	8	8	bits	
Conversion time	—	—	10	μs	20-pF capacitive load
Absolute accuracy	—	± 1.5	± 2.0	LSB	2-M Ω resistive load
	—	—	± 1.5	LSB	4-M Ω resistive load

24.4.7 Flash Memory Characteristics

Table 24-46 shows the flash memory characteristics.

Table 24-46 Flash Memory Characteristics

Conditions: $V_{CC}=4.5\text{ V to }5.5\text{ V}$, $PWMV_{CC}=4.5\text{ V to }5.5\text{ V}$, $AV_{CC}=4.5\text{ V to }5.5\text{ V}$,
 $V_{ref}=4.5\text{ V to }AV_{CC}$, $V_{SS}=PWMV_{SS}=PLL_{V_{SS}}$, $AV_{SS}=0\text{ V}$
 $T_a=0\text{ to }+75^\circ\text{C}$ (Programming/erasing operating temperature range: regular specification)

Item	Symbol	Min.	Typ.	Max.	Unit	Test Condition	
Programming time ^{*1 *2 *4}	t_P	—	10	200	ms/ 128 bytes		
Erase time ^{*1 *3 *5}	t_E	—	100	1200	ms/block		
Reprogramming count	N_{WEC}	—	—	100	Times		
Programming	Wait time after SWE bit setting ^{*1}	t_{SSWE}	1	1	—	μs	
	Wait time after PSU bit setting ^{*1}	t_{SPSU}	50	50	—	μs	
	Wait time after P bit setting ^{*1 *4}	t_{SP30}	28	30	32	μs	Programming time wait
		t_{SP200}	198	200	202	μs	Programming time wait
		t_{SP10}	8	10	12	μs	Additional-programming time wait
	Wait time after P bit clear ^{*1}	t_{CP}	5	5	—	μs	
	Wait time after PSU bit clear ^{*1}	t_{CPSU}	5	5	—	μs	
	Wait time after PV bit setting ^{*1}	t_{SPV}	4	4	—	μs	
	Wait time after H'FF dummy write ^{*1}	t_{SPVR}	2	2	—	μs	
	Wait time after PV bit clear ^{*1}	t_{CPV}	2	2	—	μs	
Wait time after SWE bit clear ^{*1}	t_{CSWE}	100	100	—	μs		
Maximum programming count ^{*1 *4}	N	—	—	1000	Times		
Erase	Wait time after SWE bit setting ^{*1}	t_{SSWE}	1	1	—	μs	
	Wait time after ESU bit setting ^{*1}	t_{SESU}	100	100	—	μs	
	Wait time after E bit setting ^{*1 *5}	t_{SE}	10	10	100	ms	Erase time wait
	Wait time after E bit clear ^{*1}	t_{CE}	10	10	—	μs	
	Wait time after ESU bit clear ^{*1}	t_{CESU}	10	10	—	μs	
	Wait time after EV bit setting ^{*1}	t_{SEV}	20	20	—	μs	

Item		Symbol	Min.	Typ.	Max.	Unit	Test Condition
Erase	Wait time after H'FF dummy write*1	t_{sevr}	2	2	—	μs	
	Wait time after EV bit clear*1	t_{cev}	4	4	—	μs	
	Wait time after SWE bit clear*1	t_{cswe}	100	100	—	μs	
	Maximum erase count*1 *5	N	12	—	120	Times	

- Notes: 1. Make each time setting in accordance with the program/program-verify flowchart or erase/erase-verify flowchart.
2. Programming time per 128 bytes (Shows the total period for which the P-bit in the flash memory control register (FLMCR1) is set. It does not include the programming verification time)
3. Block erase time (Shows the total period for which the E-bit in FLMCR1 is set. It does not include the erase verification time)
4. To specify the maximum programming time value (t_p (max.)) in the 128-byte programming algorithm, set the max. value (1000) for the maximum programming count (N).

The wait time after P bit setting should be changed as follows according to the value of the programming counter (n).

Programming counter (n) = 1 to 6: $t_{sp30} = 30 \mu\text{s}$

Programming counter (n) = 7 to 1000: $t_{sp200} = 200 \mu\text{s}$

[In additional programming]

Programming counter (n)= 1 to 6: $t_{sp10} = 10 \mu\text{s}$

5. For the maximum erase time (t_E (max.)), the following relationship applies between the wait time after E bit setting (t_{se}) and the maximum erase count (N):

$$t_E (\text{max.}) = \text{Wait time after E bit setting } (t_{se}) \times \text{maximum erase count } (N)$$

To set the maximum erase time, the values of (t_{se}) and (N) should be set so as to satisfy the above formula.

Examples: When $t_{se} = 100$ [ms], N = 12 times

When $t_{se} = 10$ [ms], N = 120 times

24.5 Operation Timing

The operation timing is shown below.

24.5.1 Clock Timing

The clock timing is shown below.

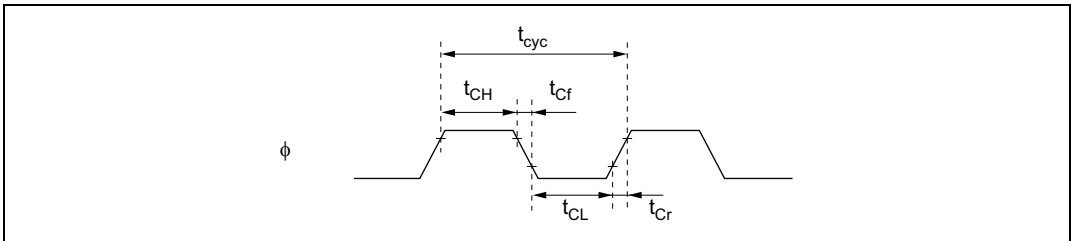

Figure 24-9 System Clock Timing

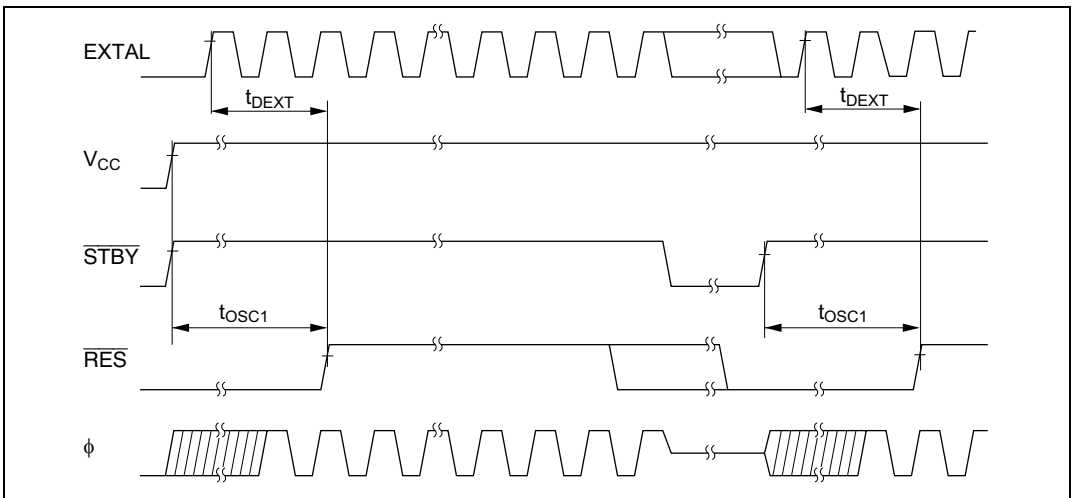

Figure 24-10 Oscillator Settling Timing

24.5.2 Control Signal Timing

The control signal timing is shown below.

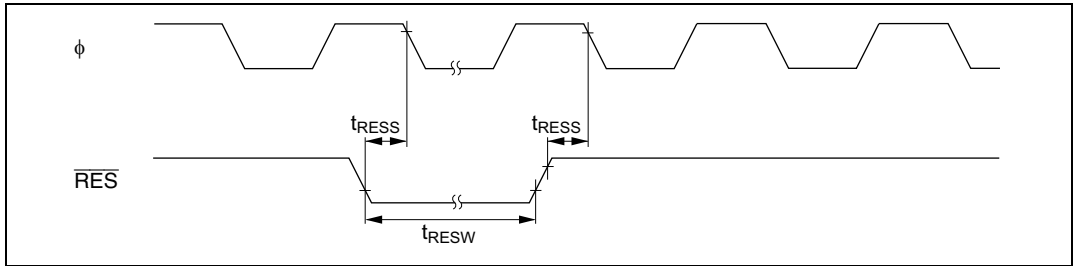

Figure 24-11 Reset Input Timing

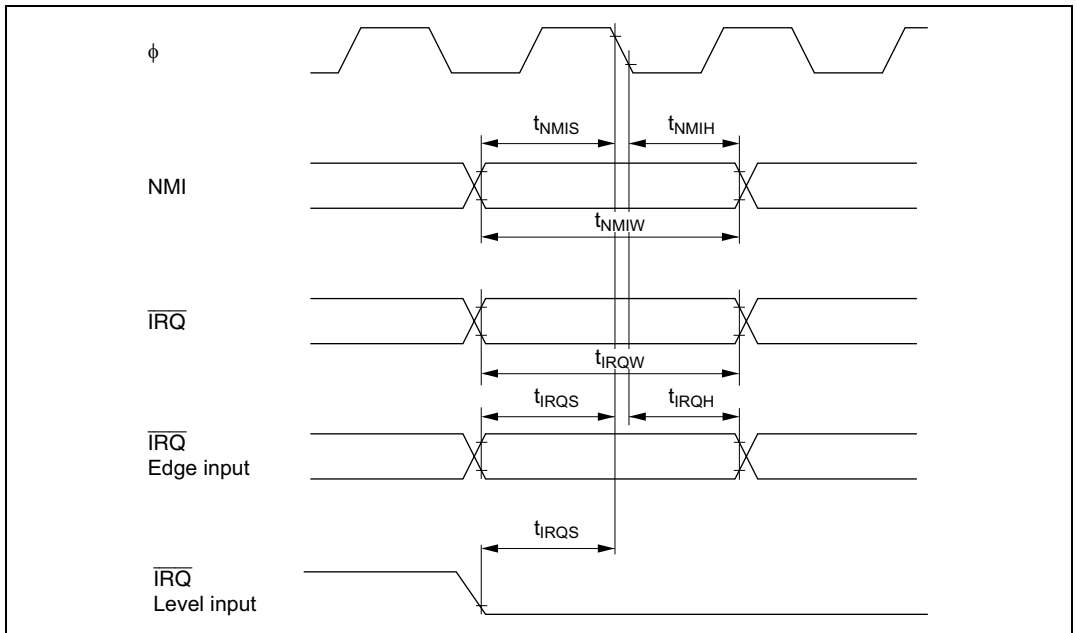

Figure 24-12 Interrupt Input Timing

24.5.3 Bus Timing

The bus timing is shown below.

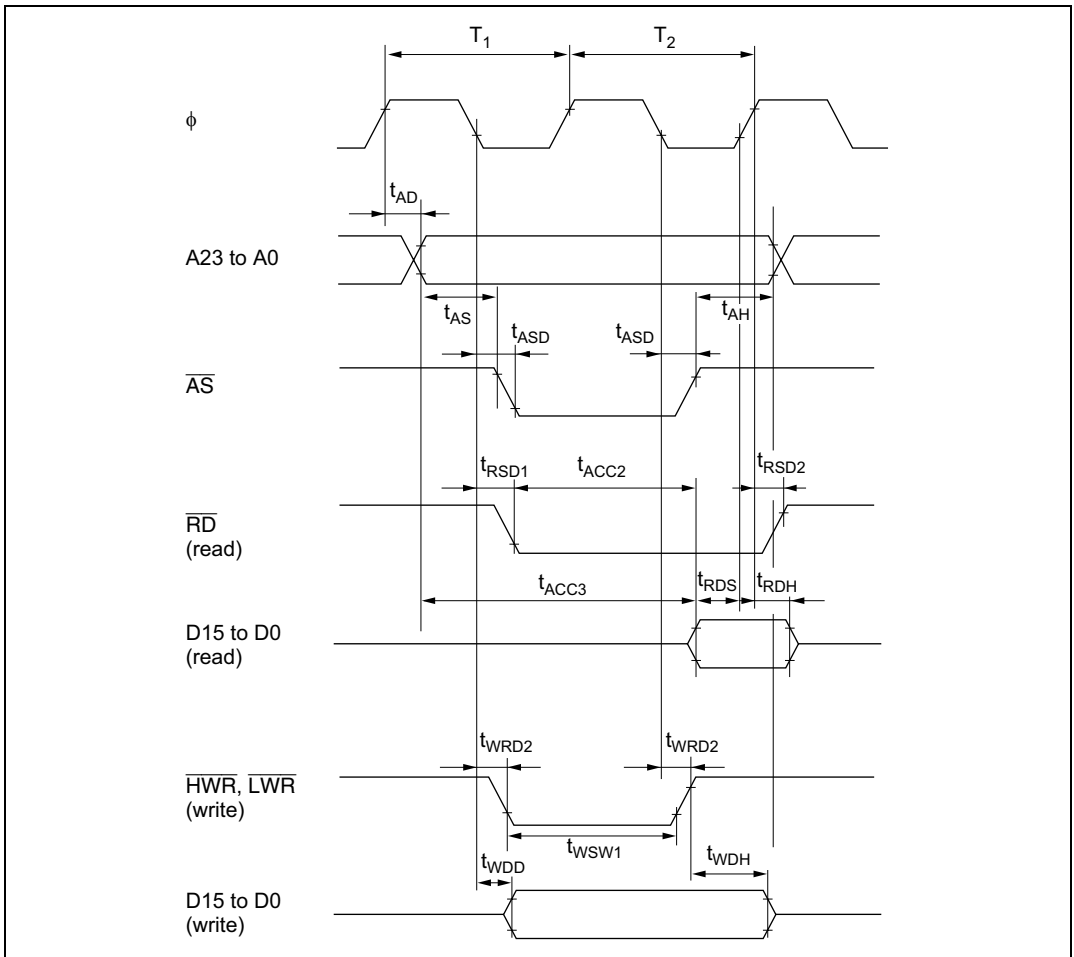

Figure 24-13 Basic Bus Timing (Two-State Access)

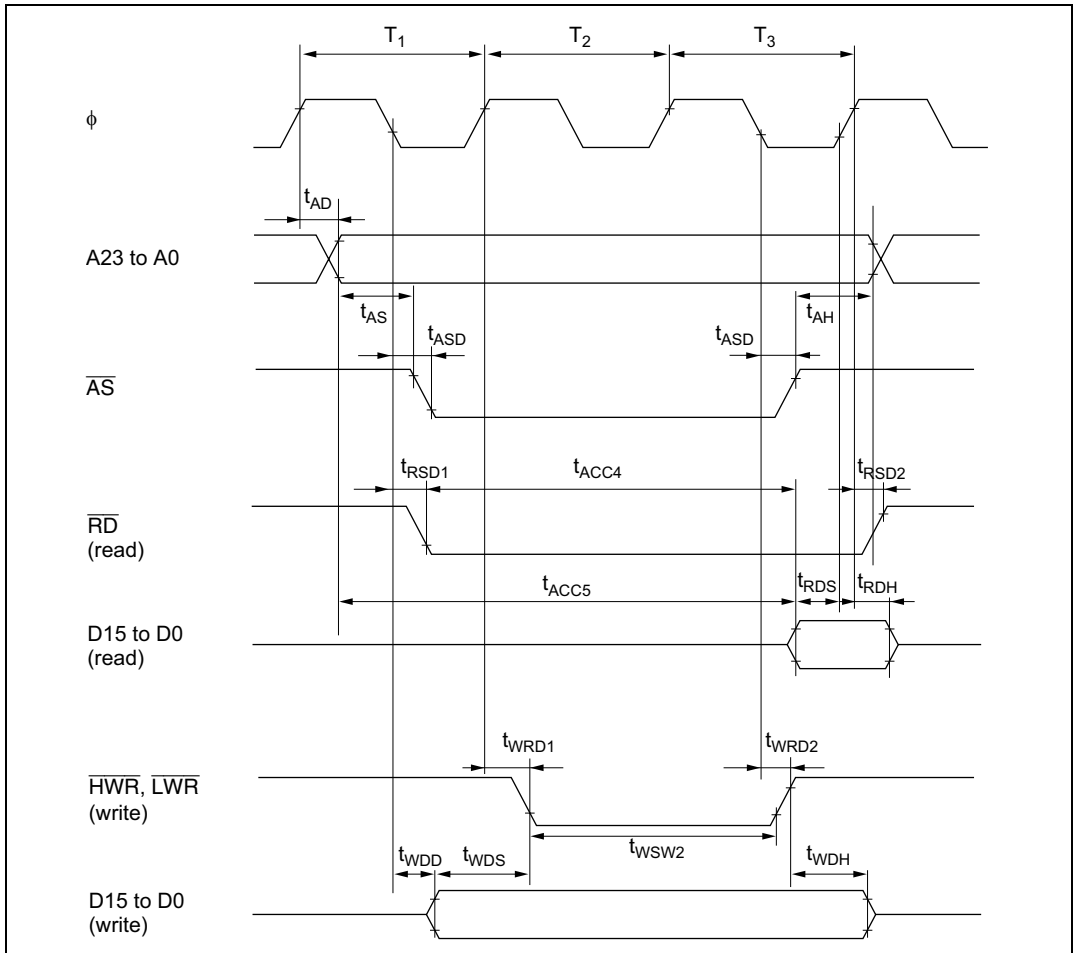

Figure 24-14 Basic Bus Timing (Three-State Access)

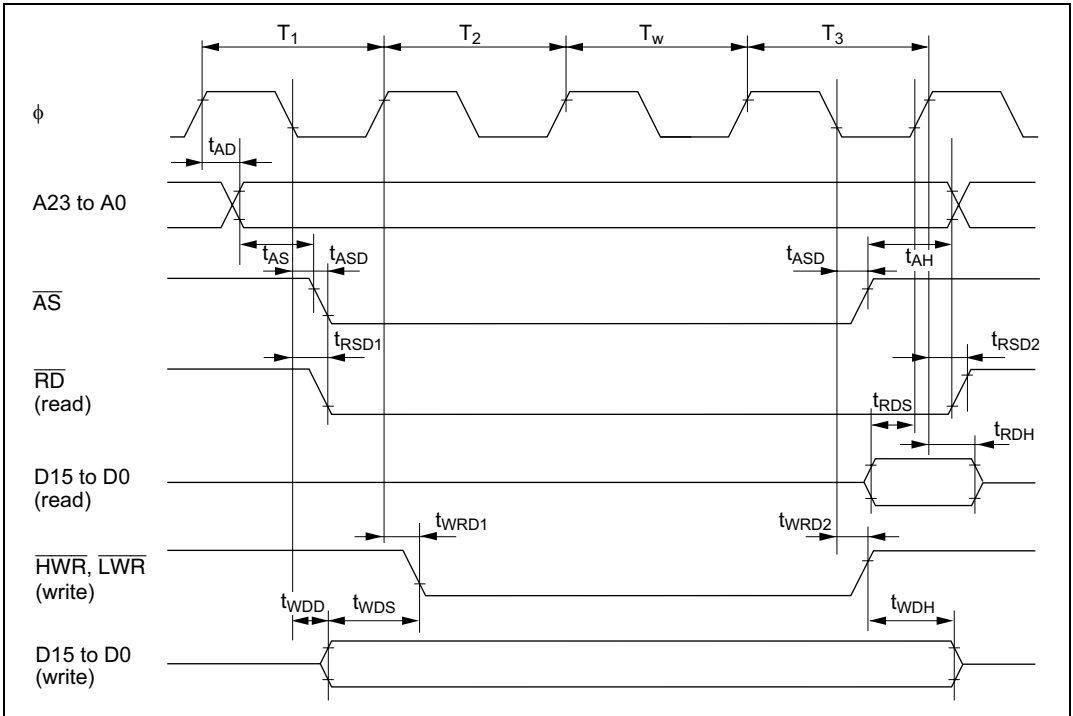

Figure 24-15 Basic Bus Timing (Three-State Access with One Wait State)

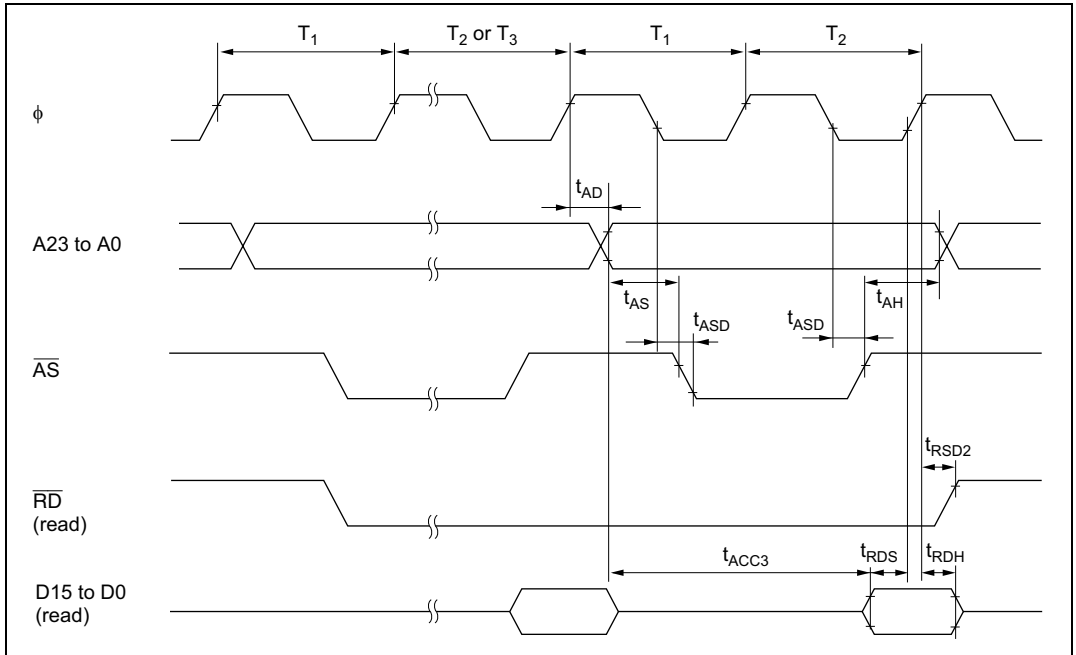

Figure 24-16 Burst ROM Access Timing (Two-State Access)

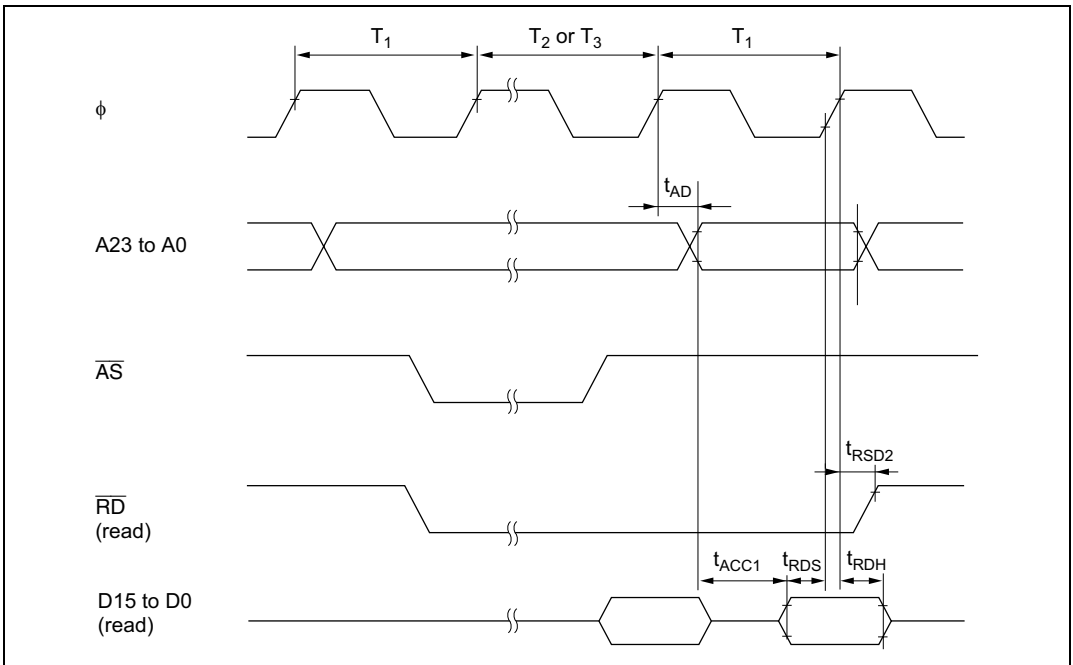

Figure 24-17 Burst ROM Access Timing (One-State Access)

24.5.4 On-Chip Supporting Module Timing

The on-chip supporting module timing is shown below.

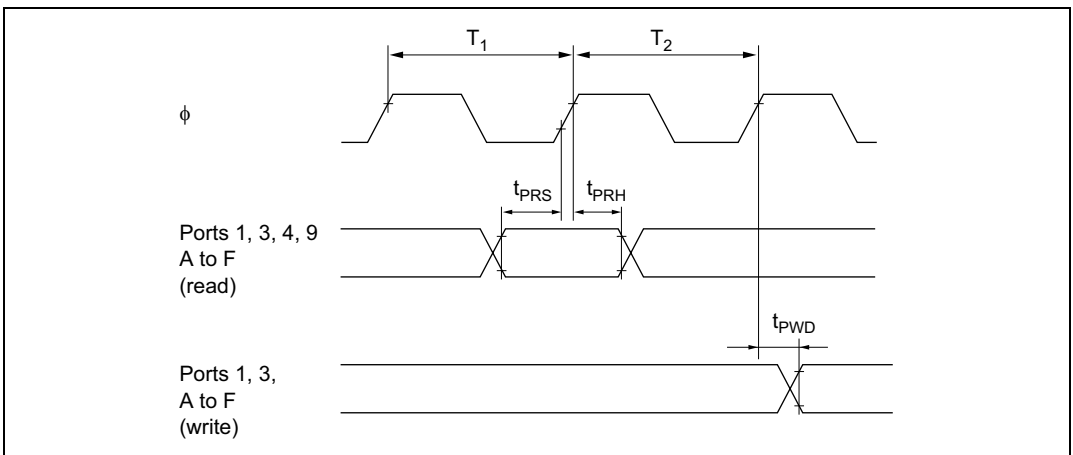

Figure 24-18 I/O Port Input/Output Timing (Ports 1, 3, 4, 9, A to F)

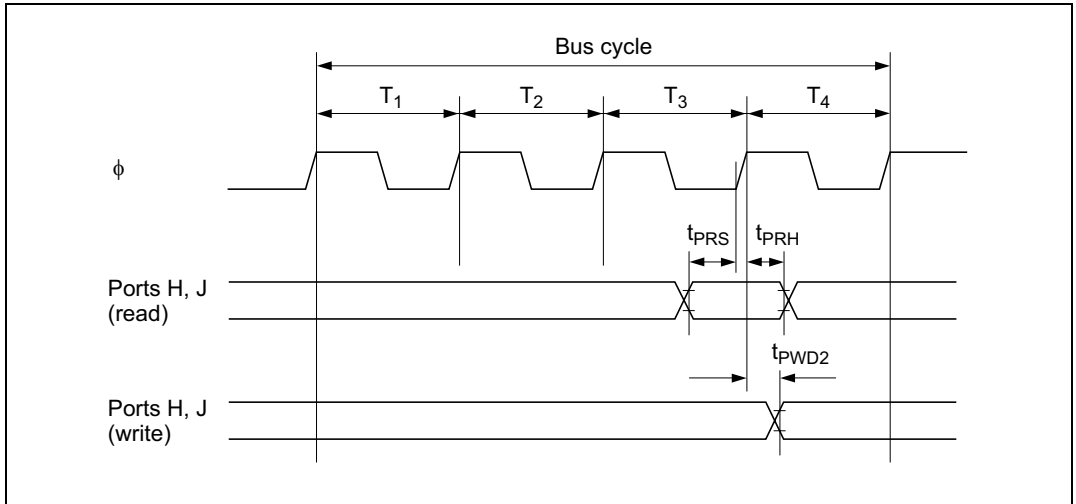

Figure 24-19 I/O Port (Ports H and J) Input/Output Timing

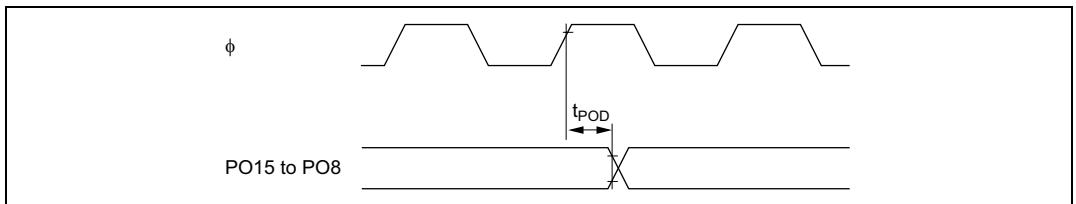

Figure 24-20 PPG Output Timing*

Note: * The PPG output is not implemented in the H8S/2635 and H8S/2634.

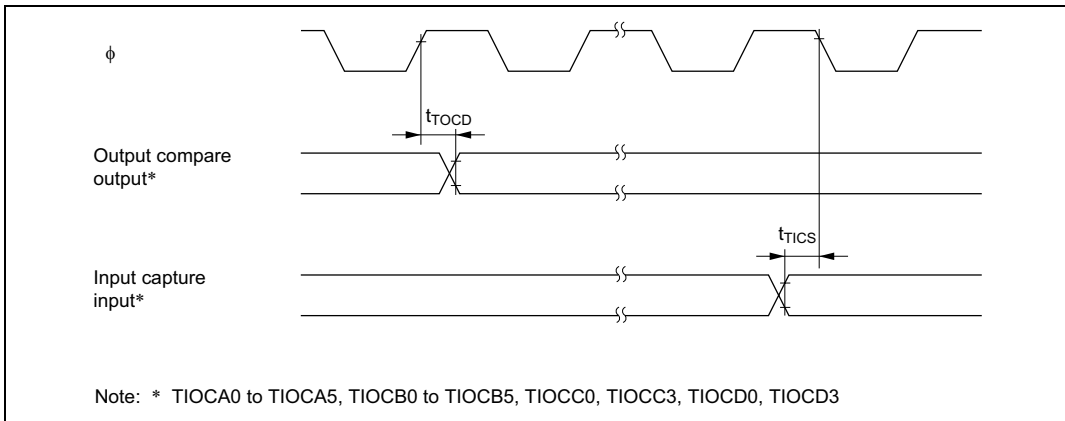

Figure 24-21 TPU Input/Output Timing

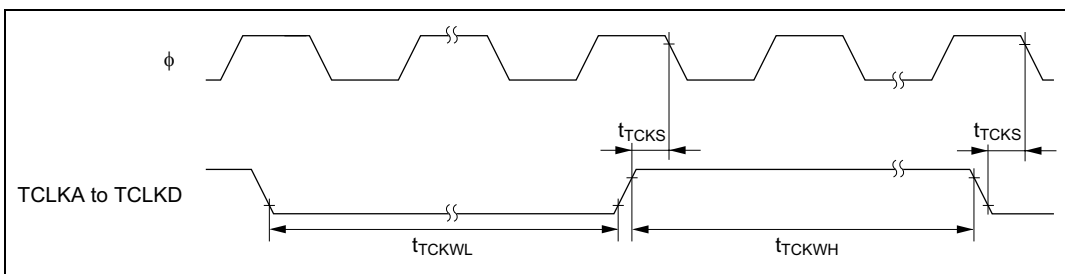

Figure 24-22 TPU Clock Input Timing

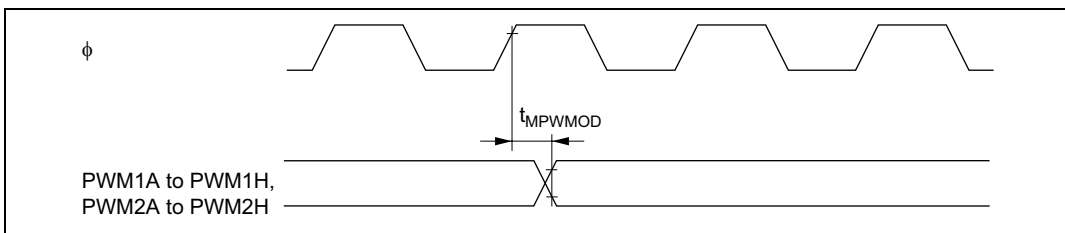

Figure 24-23 Motor Control PWM Output Timing

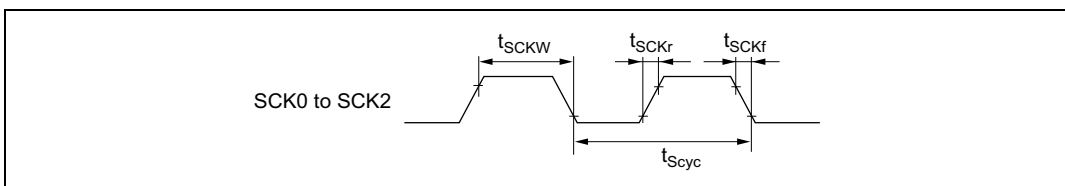

Figure 24-24 SCK Clock Input Timing

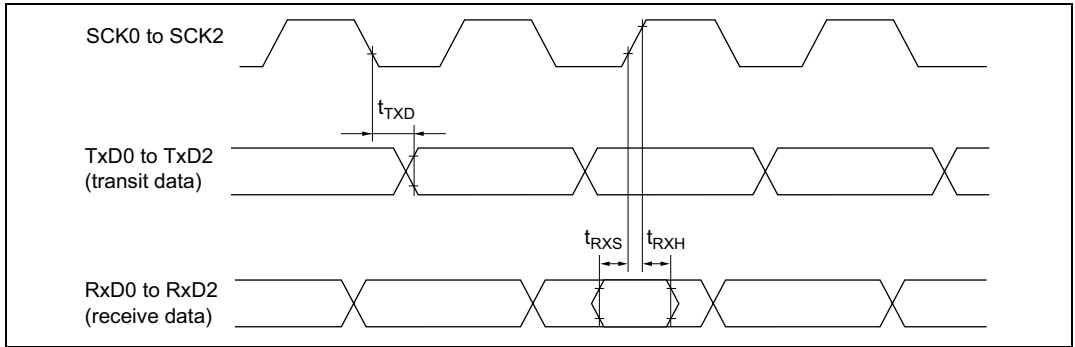

Figure 24-25 SCI Input/Output Timing (Clock Synchronous Mode)

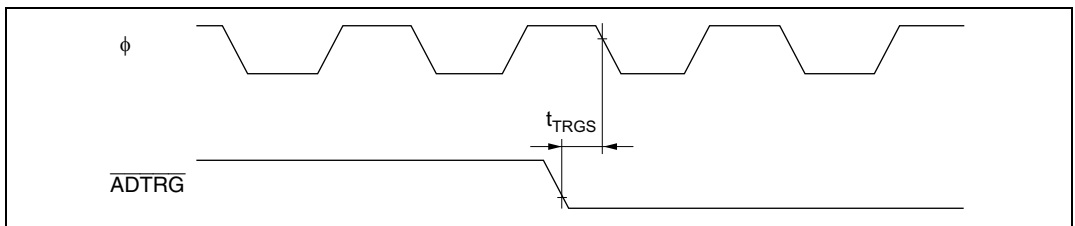

Figure 24-26 A/D Converter External Trigger Input Timing

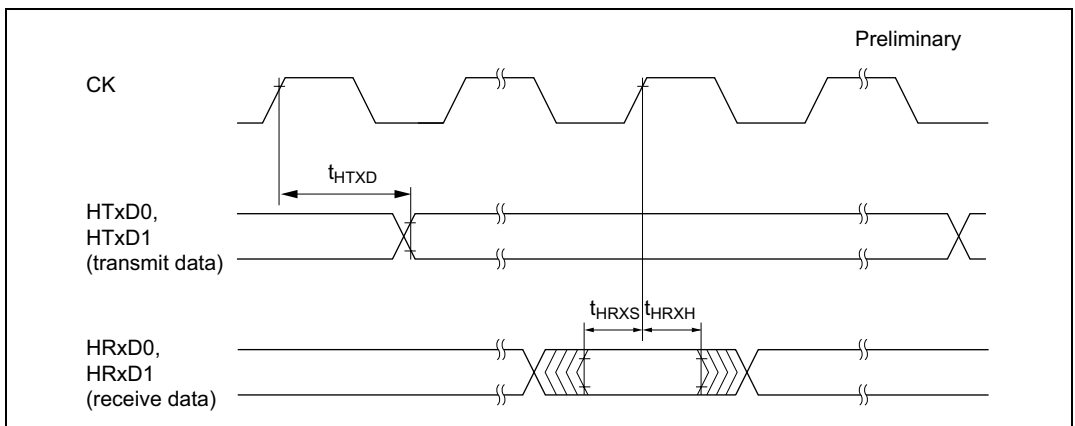

Figure 24-27 HCAN Input/Output Timing

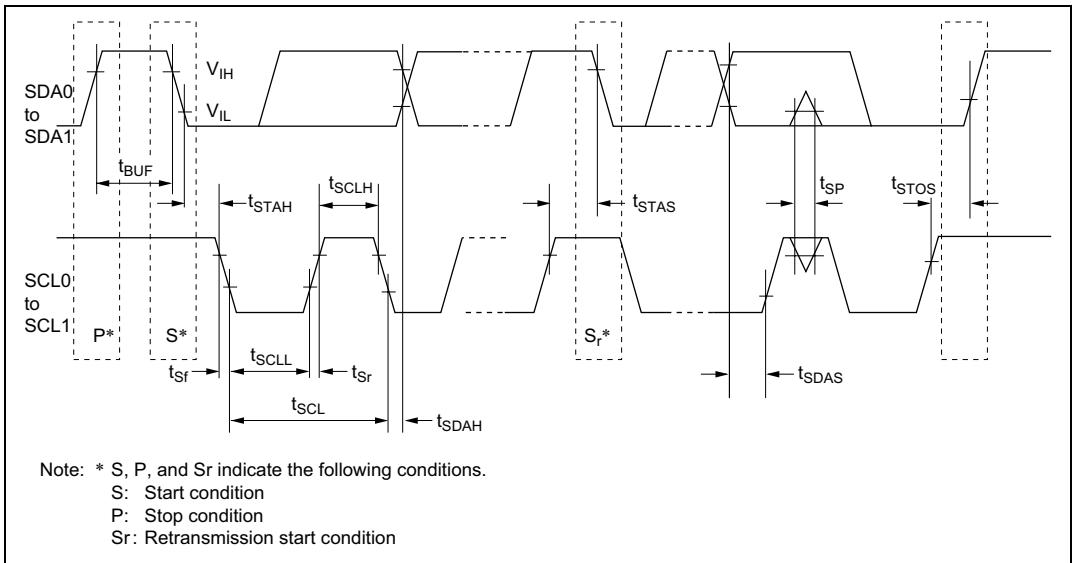

Figure 24-28 I²C Bus Interface Input/Output Timing (Option)*

Note: * I²C bus interface is available as an option in the H8S/2638, H8S/2639, and H8S/2630 only.

24.6 Usage Note

Although both the F-ZTAT and mask ROM versions fully meet the electrical specifications listed in this manual, there may be differences in the actual values of the electrical characteristics, operating margins, noise margins, and so forth, due to differences in the fabrication process, the on-chip ROM, and the layout patterns.

Therefore, if a system is evaluated using the F-ZTAT version, a similar evaluation should also be performed using the mask ROM version.

Appendix A Instruction Set

A.1 Instruction List

Operand Notation

Rd	General register (destination)*
Rs	General register (source)*
Rn	General register*
ERn	General register (32-bit register)
MAC	Multiply-and-accumulate register (32-bit register)
(EAd)	Destination operand
(EAs)	Source operand
EXR	Extended control register
CCR	Condition-code register
N	N (negative) flag in CCR
Z	Z (zero) flag in CCR
V	V (overflow) flag in CCR
C	C (carry) flag in CCR
PC	Program counter
SP	Stack pointer
#IMM	Immediate data
disp	Displacement
+	Add
-	Subtract
×	Multiply
÷	Divide
^	Logical AND
∨	Logical OR
⊕	Logical exclusive OR
→	Transfer from the operand on the left to the operand on the right, or transition from the state on the left to the state on the right
¬	Logical NOT (logical complement)
() < >	Contents of operand
:8/:16/:24/:32	8-, 16-, 24-, or 32-bit length

Note: * General registers include 8-bit registers (R0H to R7H, R0L to R7L), 16-bit registers (R0 to R7, E0 to E7), and 32-bit registers (ER0 to ER7).

Condition Code Notation**Symbol**

↑↓	Changes according to the result of instruction
*	Undetermined (no guaranteed value)
0	Always cleared to 0
1	Always set to 1
—	Not affected by execution of the instruction

Table A-1 Instruction Set

(1) Data Transfer Instructions

Mnemonic	Operand Size	Addressing Mode/ Instruction Length (Bytes)							Operation	Condition Code				No. of States*1			
		#xx	Rn	@ERn	@(d,ERn)	@ERn/@ERn+	@aa	@(d,PC)		@aa	I	H	N	Z	V	C	Advanced
MOV	B	2							#xx:8→Rd8	—	—	—	—	—	—	1	
	B		2						Rs8→Rd8	—	—	—	—	—	—	1	
	B			2					@ERs→Rd8	—	—	—	—	—	—	2	
	B				4				@(d:16,ERs)→Rd8	—	—	—	—	—	—	3	
	B					8			@(d:32,ERs)→Rd8	—	—	—	—	—	—	5	
	B			2					@ERs→Rd8,ERs32+1→ERs32	—	—	—	—	—	—	3	
	B				2				@aa:8→Rd8	—	—	—	—	—	—	2	
	B				4				@aa:16→Rd8	—	—	—	—	—	—	3	
	B				6				@aa:32→Rd8	—	—	—	—	—	—	4	
	B		2						Rs8→@ERd	—	—	—	—	—	—	2	
	B			4					Rs8→@(d:16,ERd)	—	—	—	—	—	—	3	
	B				8				Rs8→@(d:32,ERd)	—	—	—	—	—	—	5	
	B					2			ERd32-1→ERd32,Rs8→@ERd	—	—	—	—	—	—	3	
	B						2		Rs8→@aa:8	—	—	—	—	—	—	2	
	B						4		Rs8→@aa:16	—	—	—	—	—	—	3	
	B						6		Rs8→@aa:32	—	—	—	—	—	—	4	
	W	4							#xx:16→Rd16	—	—	—	—	—	—	2	
	W		2						Rs16→Rd16	—	—	—	—	—	—	1	
	W						2		@ERs→Rd16	—	—	—	—	—	—	2	

Mnemonic	Operand Size	Addressing Mode/ Instruction Length (Bytes)						Operation	Condition Code							No. of States*1
		#xx	Rn	@ERn	@(d,ERn)	@ERn/@ERn+	@aa		@(d,PC)	@aa	I	H	N	Z	V	
MOV	W		4					@(d:16,ERs)→Rd16	—	—	↑	↓	0	—	—	3
	W		8					@(d:32,ERs)→Rd16	—	—	↑	↓	0	—	—	5
	W		2					@ERs→Rd16,ERs32+2→ERs32	—	—	↑	↓	0	—	—	3
	W			4				@aa:16→Rd16	—	—	↑	↓	0	—	—	3
	W			6				@aa:32→Rd16	—	—	↑	↓	0	—	—	4
	W		2					Rs16→@ERd	—	—	↑	↓	0	—	—	2
	W		4					Rs16→@(d:16,ERd)	—	—	↑	↓	0	—	—	3
	W		8					Rs16→@(d:32,ERd)	—	—	↑	↓	0	—	—	5
	W		2					ERd32-2→ERd32,Rs16→@ERd	—	—	↑	↓	0	—	—	3
	W			4				Rs16→@aa:16	—	—	↑	↓	0	—	—	3
	W			6				Rs16→@aa:32	—	—	↑	↓	0	—	—	4
	L	6						#xx:32→ERd32	—	—	↑	↓	0	—	—	3
	L		2					ERs32→ERd32	—	—	↑	↓	0	—	—	1
	L		4					@ERs→ERd32	—	—	↑	↓	0	—	—	4
	L		6					@(d:16,ERs)→ERd32	—	—	↑	↓	0	—	—	5
	L		10					@(d:32,ERs)→ERd32	—	—	↑	↓	0	—	—	7
L		4					@ERs→ERd32,ERs32+4→ERs32	—	—	↑	↓	0	—	—	5	
L		6					@aa:16→ERd32	—	—	↑	↓	0	—	—	5	
L		8					@aa:32→ERd32	—	—	↑	↓	0	—	—	6	

Mnemonic	Operand Size	Addressing Mode/ Instruction Length (Bytes)						Operation	Condition Code					No. of States ^{*1}			
		#xx	Rn	@ERn	@ERn	@ERn/ERn+	@aa		@aa	@aa	@aa	I	H	Z	V	C	Advanced
MOV	L		4					ERS32→@ERd	↕	↕	↕	0	—	—	4		
	L			6				ERS32→@(d:16,ERd)	↕	↕	↕	0	—	—	5		
	L			10				ERS32→@(d:32,ERd)	↕	↕	↕	0	—	—	7		
	L			4				ERd32-4→ERd32,ERS32→@ERd	↕	↕	↕	0	—	—	5		
	L			6				ERS32→@aa:16	↕	↕	↕	0	—	—	5		
	L			8				ERS32→@aa:32	↕	↕	↕	0	—	—	6		
POP	W						2	@SP→Rn16,SP+2→SP	↕	↕	↕	0	—	—	3		
	L						4	@SP→ERn32,SP+4→SP	↕	↕	↕	0	—	—	5		
PUSH	W						2	SP-2→SP,Rn16→@SP	↕	↕	↕	0	—	—	3		
	L						4	SP-4→SP,ERn32→@SP	↕	↕	↕	0	—	—	5		
LDM ^{*4}	L						4	(@SP→ERn32,SP+4→SP) Repeated for each register restored	—	—	—	—	—	—	7/9/11 [1]		
	L						4	(SP-4→SP,ERn32→@SP) Repeated for each register saved	—	—	—	—	—	—	7/9/11 [1]		
MOVFP								Cannot be used in this LSI							[2]		
MOVTP								Cannot be used in this LSI							[2]		

(2) Arithmetic Instructions

Mnemonic	Operand Size	Addressing Mode/ Instruction Length (Bytes)						Operation	Condition Code							No. of States*1 Advanced
		#xx	R5	@ERn	@(d,ERn)	@-ERn/@ERn+	@aa		@(d,PC)	@aa	I	H	N	Z	V	
ADD	B 2							Rd8+#xx:8→Rd8	—	↕	↕	↕	↕	↕	↕	1
	B 2							Rd8+Rs8→Rd8	—	↕	↕	↕	↕	↕	↕	1
ADD.W	W 4							Rd16+#xx:16→Rd16	—	[3]	↕	↕	↕	↕	↕	2
	W 2							Rd16+Rs16→Rd16	—	[3]	↕	↕	↕	↕	↕	1
ADD.L	L 6							ERd32+#xx:32→ERd32	—	[4]	↕	↕	↕	↕	↕	3
	L 2							ERd32+ERs32→ERd32	—	[4]	↕	↕	↕	↕	↕	1
ADDX	B 2							Rd8+#xx:8+C→Rd8	—	↕	↕	[5]	↕	↕	↕	1
	B 2							Rd8+Rs8+C→Rd8	—	↕	↕	[5]	↕	↕	↕	1
ADDS	L 2							ERd32+1→ERd32	—	—	—	—	—	—	—	1
	L 2							ERd32+2→ERd32	—	—	—	—	—	—	—	1
ADDS #4,ERd	L 2							ERd32+4→ERd32	—	—	—	—	—	—	—	1
	B 2							Rd8+1→Rd8	—	↕	↕	↕	↕	↕	↕	1
INC	W 2							Rd16+1→Rd16	—	↕	↕	↕	↕	↕	↕	1
	W 2							Rd16+2→Rd16	—	↕	↕	↕	↕	↕	↕	1
INC.L #1,ERd	L 2							ERd32+1→ERd32	—	↕	↕	↕	↕	↕	↕	1
	L 2							ERd32+2→ERd32	—	↕	↕	↕	↕	↕	↕	1
DAA	B 2							Rd8 decimal adjust→Rd8	—	*	↕	↕	↕	*	↕	1
	B 2							Rd8-Rs8→Rd8	—	↕	↕	↕	↕	↕	↕	1
SUB	W 4							Rd16+#xx:16→Rd16	—	[3]	↕	↕	↕	↕	↕	2

Mnemonic	Operand Size	Addressing Mode/ Instruction Length (Bytes)							Operation	Condition Code					No. of States ^{#1} Advanced						
		#xx	Rn	@ERN	@d,ERn	@ERN/@ERn+	@aa	@d,PC		@aa	I	H	N	Z		V	C				
																		W	L	B	B
SUB	SUB.W Rs,Rd	W	2													[3]	↑	↑	↑	↑	1
	SUB.L #xx:32,ERd	L	6														[4]	↑	↑	↑	3
	SUB.L ERs,ERd	L	2														[4]	↑	↑	↑	1
	SUBX #xx:8,Rd	B	2														↑	↑	[5]	↑	1
SUBS	SUBX Rs,Rd	B	2														↑	↑	[5]	↑	1
	SUBS #1,ERd	L	2														—	—	—	—	1
	SUBS #2,ERd	L	2														—	—	—	—	1
	SUBS #4,ERd	L	2														—	—	—	—	1
DEC	DEC.B Rd	B	2														↑	↑	—	—	1
	DEC.W #1,Rd	W	2														↑	↑	—	—	1
	DEC.W #2,Rd	W	2														↑	↑	—	—	1
	DEC.L #1,ERd	L	2														↑	↑	—	—	1
DAS	DEC.L #2,ERd	L	2														↑	↑	—	—	1
	DAS Rd	B	2														*	↑	↑	*	1
	MULXU.B Rs,Rd	B	2														—	—	—	—	3
	MULXU.W Rs,ERd	W	2														—	—	—	—	4
MULXS	MULXS.B Rs,Rd	B	4														↑	↑	—	—	4
	MULXS.W Rs,ERd	W	4														↑	↑	—	—	5

Mnemonic	Operand Size	Addressing Mode/ Instruction Length (Bytes)							Operation	Condition Code							No. of States*1
		#xx	Rn	@ERn	@(d,ERn)	@-ERn/@ERn+	@aa	@(d,PC)		@aa	I	H	N	Z	V	C	
DIVXU	B	2							Rd16←Rs8→Rd16 (RdH: remainder, RdL: quotient) (unsigned division)	—	—	[6]	[7]	—	—	12	
	W	2							ERd32←Rs16→ERd32 (Ed: remainder, Rd: quotient) (unsigned division)	—	—	[6]	[7]	—	—	20	
DIVXS	B	4							Rd16←Rs8→Rd16 (RdH: remainder, RdL: quotient) (signed division)	—	—	[8]	[7]	—	—	13	
	W	4							ERd32←Rs16→ERd32 (Ed: remainder, Rd: quotient) (signed division)	—	—	[8]	[7]	—	—	21	
CMP	B	2							Rd8←#xx:8	—	—	↑	↑	↑	↑	1	
	B	2							Rd8←Rs8	—	—	↑	↑	↑	↑	1	
	W	4							Rd16←#xx:16	—	[3]	↑	↑	↑	↑	2	
	W	2							Rd16←Rs16	—	[3]	↑	↑	↑	↑	1	
	L	6							ERd32←#xx:32	—	[4]	↑	↑	↑	↑	3	
	L	2							ERd32←ERs32	—	[4]	↑	↑	↑	↑	1	
NEG	B	2							0←Rd8→Rd8	—	—	↑	↑	↑	↑	1	
	W	2							0←Rd16→Rd16	—	—	↑	↑	↑	↑	1	
	L	2							0←ERd32→ERd32	—	—	↑	↑	↑	↑	1	
EXTU	W	2							0→(<bit 15 to 8> of Rd16)	—	—	0	↑	0	—	1	
	L	2							0→(<bit 31 to 16> of ERd32)	—	—	0	↑	0	—	1	

Mnemonic	Operand Size	Addressing Mode/ Instruction Length (Bytes)						Operation	Condition Code				No. of States*1				
		#xx	Rn	@ERn	@d,ERn	@ERn/@ERn+	@aa		@d,PC	@aa	I	H		N	Z	V	C
EXTS	W	2						(<bit 7> of Rd16)→ (<bit 15 to 8> of Rd16)	—	—	—	—	—	—	—	1	
EXTS.L ERd	L	2						(<bit 15> of ERd32)→ (<bit 31 to 16> of ERd32)	—	—	—	—	—	—	—	1	
TAS @ERd *3	B	4						@ERd-0→CCR set, (1)→ (<bit 7> of @ERd)	—	—	—	—	—	—	—	4	
MAC @ERn+, @ERn+	—		4					@ERn×@ERm+MAC→MAC (signed multiplication) ERn+2→ERn, ERm+2→ERm	—	—	—	—	—	—	—	4	
CLRMAC	—						2	0→MACH, MACL	—	—	—	—	—	—	—	2 [11]	
LDMAC	L	2						ERs→MACH	—	—	—	—	—	—	—	2 [11]	
LDMAC	L	2						ERs→MACL	—	—	—	—	—	—	—	2 [11]	
STMAC	L	2						MACH→ERd	—	—	—	—	—	—	—	1 [11]	
STMAC	L	2						MACL→ERd	—	—	—	—	—	—	—	1 [11]	

(4) Shift Instructions

Mnemonic	Operand Size	Addressing Mode/ Instruction Length (Bytes)							Operation	Condition Code				No. of States*1 Advanced		
		#xx	Rn	@ERn	@(d,ERn)	@ERn/@ERn+	@aa	@(d,PC)		@aa	I	H	N		Z	V
SHAL	B	2										↕	↕	↕	↕	1
	B	2										↕	↕	↕	↕	1
	W	2										↕	↕	↕	↕	1
	W	2										↕	↕	↕	↕	1
	L	2										↕	↕	↕	↕	1
	L	2										↕	↕	↕	↕	1
SHAR	B	2										↕	↕	0	↕	1
	B	2										↕	↕	0	↕	1
	W	2										↕	↕	0	↕	1
	W	2										↕	↕	0	↕	1
	L	2										↕	↕	0	↕	1
	L	2										↕	↕	0	↕	1
SHLL	B	2										↕	↕	0	↕	1
	B	2										↕	↕	0	↕	1
	W	2										↕	↕	0	↕	1
	W	2										↕	↕	0	↕	1
	L	2										↕	↕	0	↕	1
	L	2										↕	↕	0	↕	1

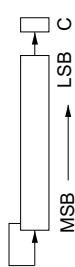
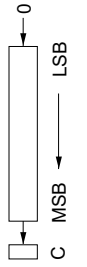

Mnemonic	Operand Size	Addressing Mode/ Instruction Length (Bytes)							Operation	Condition Code							No. of States*1
		#xx	Rn	@ERn	@(d,ERn)	@-ERn/@ERn+	@aa	@(d,PC)		@@aa	I	H	N	Z	V	C	
SHLR	SHLR.B Rd	B	2									0	↑	0	↔	1	
	SHLR.B #2,Rd	B	2									0	↑	0	↔	1	
	SHLR.W Rd	W	2									0	↑	0	↔	1	
	SHLR.W #2,Rd	W	2									0	↑	0	↔	1	
	SHLR.L ERd	L	2									0	↑	0	↔	1	
	SHLR.L #2,ERd	L	2									0	↑	0	↔	1	
ROTXL	ROTXL.B Rd	B	2									↑	↑	0	↔	1	
	ROTXL.B #2,Rd	B	2									↑	↑	0	↔	1	
	ROTXL.W Rd	W	2									↑	↑	0	↔	1	
	ROTXL.W #2,Rd	W	2									↑	↑	0	↔	1	
	ROTXL.L ERd	L	2									↑	↑	0	↔	1	
	ROTXL.L #2,ERd	L	2									↑	↑	0	↔	1	
ROTXR	ROTXR.B Rd	B	2									↑	↑	0	↔	1	
	ROTXR.B #2,Rd	B	2									↑	↑	0	↔	1	
	ROTXR.W Rd	W	2									↑	↑	0	↔	1	
	ROTXR.W #2,Rd	W	2									↑	↑	0	↔	1	
	ROTXR.L ERd	L	2									↑	↑	0	↔	1	
	ROTXR.L #2,ERd	L	2									↑	↑	0	↔	1	

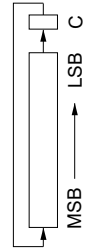

Mnemonic	Operand Size	Addressing Mode/ Instruction Length (Bytes)						Operation	Condition Code					No. of States*1 Advanced		
		#xx	Rn	@ERn	@(d,ERn)	@ERN/@ERn+	@aa		@(d,PC)	@@aa	I	H	N		Z	V
ROTL	ROTL.B Rd	B	2						↕	↕	↕	↕	↕	↕	↕	1
	ROTL.B #2,Rd	B	2						↕	↕	↕	↕	↕	↕	↕	1
	ROTL.W Rd	W	2						↕	↕	↕	↕	↕	↕	↕	1
	ROTL.W #2,Rd	W	2						↕	↕	↕	↕	↕	↕	↕	1
	ROTL.L ERd	L	2							↕	↕	↕	↕	↕	↕	1
	ROTL.L #2,ERd	L	2							↕	↕	↕	↕	↕	↕	1
ROTR	ROTR.B Rd	B	2						↕	↕	↕	↕	↕	↕	↕	1
	ROTR.B #2,Rd	B	2						↕	↕	↕	↕	↕	↕	↕	1
	ROTR.W Rd	W	2						↕	↕	↕	↕	↕	↕	↕	1
	ROTR.W #2,Rd	W	2						↕	↕	↕	↕	↕	↕	↕	1
	ROTR.L ERd	L	2							↕	↕	↕	↕	↕	↕	1
	ROTR.L #2,ERd	L	2							↕	↕	↕	↕	↕	↕	1

(5) Bit-Manipulation Instructions

Mnemonic	Operand Size	Addressing Mode/ Instruction Length (Bytes)						Operation	Condition Code							No. of States*1 Advanced
		#xx	Rn	@ERn	@(d,ERn)	@-ERn/@ERn+	@aa		@(d,PC)	@aa	I	H	N	Z	V	
BSET	BSET #xx:3,Rd	B	2					(#xx:3 of Rd8)←-1	—	—	—	—	—	—	—	1
	BSET #xx:3,@ERd	B	4					(#xx:3 of @ERd)←-1	—	—	—	—	—	—	—	4
	BSET #xx:3,@aa:8	B		4				(#xx:3 of @aa:8)←-1	—	—	—	—	—	—	—	4
	BSET #xx:3,@aa:16	B		6				(#xx:3 of @aa:16)←-1	—	—	—	—	—	—	—	5
	BSET #xx:3,@aa:32	B		8				(#xx:3 of @aa:32)←-1	—	—	—	—	—	—	—	6
	BSET Rn,Rd	B	2					(Rn8 of Rd8)←-1	—	—	—	—	—	—	—	1
	BSET Rn,@ERd	B	4					(Rn8 of @ERd)←-1	—	—	—	—	—	—	—	4
	BSET Rn,@aa:8	B		4				(Rn8 of @aa:8)←-1	—	—	—	—	—	—	—	4
	BSET Rn,@aa:16	B		6				(Rn8 of @aa:16)←-1	—	—	—	—	—	—	—	5
	BSET Rn,@aa:32	B		8				(Rn8 of @aa:32)←-1	—	—	—	—	—	—	—	6
BCLR	BCLR #xx:3,Rd	B	2					(#xx:3 of Rd8)←-0	—	—	—	—	—	—	—	1
	BCLR #xx:3,@ERd	B	4					(#xx:3 of @ERd)←-0	—	—	—	—	—	—	—	4
	BCLR #xx:3,@aa:8	B		4				(#xx:3 of @aa:8)←-0	—	—	—	—	—	—	—	4
	BCLR #xx:3,@aa:16	B		6				(#xx:3 of @aa:16)←-0	—	—	—	—	—	—	—	5
	BCLR #xx:3,@aa:32	B		8				(#xx:3 of @aa:32)←-0	—	—	—	—	—	—	—	6
	BCLR Rn,Rd	B	2					(Rn8 of Rd8)←-0	—	—	—	—	—	—	—	1
	BCLR Rn,@ERd	B	4					(Rn8 of @ERd)←-0	—	—	—	—	—	—	—	4
	BCLR Rn,@aa:8	B		4				(Rn8 of @aa:8)←-0	—	—	—	—	—	—	—	4
	BCLR Rn,@aa:16	B		6				(Rn8 of @aa:16)←-0	—	—	—	—	—	—	—	4
	BCLR Rn,@aa:32	B		8				(Rn8 of @aa:16)←-0	—	—	—	—	—	—	—	5

Mnemonic	Operand Size	Addressing Mode/ Instruction Length (Bytes)							Operation	Condition Code				No. of States ^{#1}			
		#xx	Rn	ERn	ERn	ERn/ERn+	@aa	@d,PC		@aa	I	H	N	Z	V	C	Advanced
BCLR	Rn,@aa:32	B					8		(Rn8 of @aa:32)←0	—	—	—	—	—	—	6	
BNOT	#xx:3,Rd	B	2						(#xx:3 of Rd8)← [-(#xx:3 of Rd8)]	—	—	—	—	—	—	1	
	@ERd	B	4						(#xx:3 of @ERd)← [- (#xx:3 of @ERd)]	—	—	—	—	—	—	4	
BNOT	#xx:3,@aa:8	B					4		(#xx:3 of @aa:8)← [- (#xx:3 of @aa:8)]	—	—	—	—	—	—	4	
	@aa:16	B					6		(#xx:3 of @aa:16)← [- (#xx:3 of @aa:16)]	—	—	—	—	—	—	5	
BNOT	#xx:3,@aa:32	B					8		(#xx:3 of @aa:32)← [- (#xx:3 of @aa:32)]	—	—	—	—	—	—	6	
	Rn,Rd	B	2						(Rn8 of Rd8)← [-(Rn8 of Rd8)]	—	—	—	—	—	—	1	
BNOT	Rn,@ERd	B	4						(Rn8 of @ERd)← [-(Rn8 of @ERd)]	—	—	—	—	—	—	4	
	@aa:8	B					4		(Rn8 of @aa:8)← [-(Rn8 of @aa:8)]	—	—	—	—	—	—	4	
BNOT	@aa:16	B					6		(Rn8 of @aa:16)← [- (Rn8 of @aa:16)]	—	—	—	—	—	—	5	
	@aa:32	B					8		(Rn8 of @aa:32)← [- (Rn8 of @aa:32)]	—	—	—	—	—	—	6	
BTST	#xx:3,Rd	B	2						(#xx:3 of Rd8)→Z	—	—	—	↑	—	—	1	
	@ERd	B	4						(#xx:3 of @ERd)→Z	—	—	—	↑	—	—	3	
BTST	@aa:8	B					4		(#xx:3 of @aa:8)→Z	—	—	—	↑	—	—	3	
	@aa:16	B					6		(#xx:3 of @aa:16)→Z	—	—	—	↑	—	—	4	

Mnemonic	Operand Size	Addressing Mode/ Instruction Length (Bytes)						Operation	Condition Code							No. of States ^{*1}	
		#xx	Rn	@ERn	@(d,ERn)	@ERn/@ERn+	@aa		@(d,PC)	@aa	I	H	N	Z	V	C	Advanced
BTST	#xx:3,@aa:32	B					8			— (#xx:3 of @aa:32) → Z	—	—	↑	—	—	—	5
	Rn,Rd	B	2							— (Rn8 of Rd8) → Z	—	—	↑	—	—	—	1
	@ERd	B		4						— (Rn8 of @ERd) → Z	—	—	↑	—	—	—	3
	@aa:8	B				4				— (Rn8 of @aa:8) → Z	—	—	↑	—	—	—	3
	@aa:16	B					6			— (Rn8 of @aa:16) → Z	—	—	↑	—	—	—	4
	@aa:32	B						8		— (Rn8 of @aa:32) → Z	—	—	↑	—	—	—	5
BLD	#xx:3,Rd	B	2							(#xx:3 of Rd8) → C	—	—	—	—	↑	—	1
	@ERd	B		4						(#xx:3 of @ERd) → C	—	—	—	—	↑	—	3
	@aa:8	B				4				(#xx:3 of @aa:8) → C	—	—	—	—	↑	—	3
	@aa:16	B					6			(#xx:3 of @aa:16) → C	—	—	—	—	↑	—	4
	@aa:32	B						8		(#xx:3 of @aa:32) → C	—	—	—	—	↑	—	5
	Rd	B	2							— (#xx:3 of Rd8) → C	—	—	—	—	↑	—	1
BILD	@ERd	B		4						— (#xx:3 of @ERd) → C	—	—	—	—	↑	—	3
	@aa:8	B				4				— (#xx:3 of @aa:8) → C	—	—	—	—	↑	—	3
	@aa:16	B					6			(#xx:3 of @aa:16) → C	—	—	—	—	↑	—	4
	@aa:32	B						8		(#xx:3 of @aa:32) → C	—	—	—	—	↑	—	5
	Rd	B	2							— (#xx:3 of Rd8) → C	—	—	—	—	↑	—	1
	@ERd	B		4						— (#xx:3 of @ERd) → C	—	—	—	—	↑	—	3
BST	@aa:8	B				4				— (#xx:3 of @aa:8) → C	—	—	—	—	↑	—	3
	@aa:16	B					6			(#xx:3 of @aa:16) → C	—	—	—	—	↑	—	4
	@aa:32	B						8		(#xx:3 of @aa:32) → C	—	—	—	—	↑	—	5
	Rd	B	2							C → (#xx:3 of Rd8)	—	—	—	—	—	—	1
	@ERd	B		4						C → (#xx:3 of @ERd24)	—	—	—	—	—	—	4
	@aa:8	B						4		C → (#xx:3 of @aa:8)	—	—	—	—	—	—	4

Mnemonic	Operand Size	Addressing Mode/ Instruction Length (Bytes)							Operation	Condition Code					No. of States ^{#1}			
		#xx	Rn	@ERn	@ERn	@ERn/@ERN+	@aa	@d,PC		@aa	I	H	N	Z	V	C	Advanced	#1
BST	B							6		C→(#xx:3 of @aa:16)	—	—	—	—	—	5		
	B							8		C→(#xx:3 of @aa:32)	—	—	—	—	—	6		
BIST	B		2							¬ C→(#xx:3 of Rd8)	—	—	—	—	—	1		
	B			4						¬ C→(#xx:3 of @ERd24)	—	—	—	—	—	4		
	B				4					¬ C→(#xx:3 of @aa:8)	—	—	—	—	—	4		
	B					6				¬ C→(#xx:3 of @aa:16)	—	—	—	—	—	5		
BAND	B							8		¬ C→(#xx:3 of @aa:32)	—	—	—	—	—	6		
	B		2							C^(#xx:3 of Rd8)→C	—	—	—	↕	—	1		
	B			4						C^(#xx:3 of @ERd24)→C	—	—	—	↕	—	3		
	B				4					C^(#xx:3 of @aa:8)→C	—	—	—	↕	—	3		
	B					6				C^(#xx:3 of @aa:16)→C	—	—	—	↕	—	4		
	B						8			C^(#xx:3 of @aa:32)→C	—	—	—	↕	—	5		
	B		2							C^(¬ (#xx:3 of Rd8))→C	—	—	—	↕	—	1		
	B			4						C^(¬ (#xx:3 of @ERd24))→C	—	—	—	↕	—	3		
BIAND	B									C^(¬ (#xx:3 of @aa:8))→C	—	—	—	↕	—	3		
	B							4		C^(¬ (#xx:3 of @aa:16))→C	—	—	—	↕	—	3		
	B								4	C^(¬ (#xx:3 of @aa:8))→C	—	—	—	↕	—	3		
	B								6	C^(¬ (#xx:3 of @aa:16))→C	—	—	—	↕	—	4		
BOR	B							8		C^(¬ (#xx:3 of @aa:32))→C	—	—	—	↕	—	5		
	B		2							C^(¬ (#xx:3 of Rd8))→C	—	—	—	↕	—	1		
	B							4		C^(¬ (#xx:3 of @ERd24))→C	—	—	—	↕	—	3		

Mnemonic	Operand Size	Addressing Mode/ Instruction Length (Bytes)						Operation	Condition Code							No. of States*1 Advanced	
		#xx Rn	@ERn	@(d,Ern)	@-Ern/@Ern+	@aa	@(d,PC) @aa		I	H	N	Z	V	C			
BOR	B					4	Cv(#xx:3 of @aa:8)→C	—	—	—	—	—	—	—	—	—	3
	B					6	Cv(#xx:3 of @aa:16)→C	—	—	—	—	—	—	—	—	—	4
	B					8	Cv(#xx:3 of @aa:32)→C	—	—	—	—	—	—	—	—	—	5
BIOR	B	2					Cv[-(#xx:3 of Rd8)]→C	—	—	—	—	—	—	—	—	—	1
	B	4					Cv[-(#xx:3 of @ERd24)]→C	—	—	—	—	—	—	—	—	—	3
	B					4	Cv[-(#xx:3 of @aa:8)]→C	—	—	—	—	—	—	—	—	—	3
	B					6	Cv[-(#xx:3 of @aa:16)]→C	—	—	—	—	—	—	—	—	—	4
	B					8	Cv[-(#xx:3 of @aa:32)]→C	—	—	—	—	—	—	—	—	—	5
	B	2					Cc[-(#xx:3 of Rd8)]→C	—	—	—	—	—	—	—	—	—	1
BXOR	B	4					Cc[-(#xx:3 of @ERd24)]→C	—	—	—	—	—	—	—	—	—	3
	B					4	Cc[-(#xx:3 of @aa:8)]→C	—	—	—	—	—	—	—	—	—	3
	B					6	Cc[-(#xx:3 of @aa:16)]→C	—	—	—	—	—	—	—	—	—	4
	B					8	Cc[-(#xx:3 of @aa:32)]→C	—	—	—	—	—	—	—	—	—	5
	B	2					Cc[-(#xx:3 of Rd8)]→C	—	—	—	—	—	—	—	—	—	1
	B	4					Cc[-(#xx:3 of @ERd24)]→C	—	—	—	—	—	—	—	—	—	3
BIXOR	B					4	Cc[-(#xx:3 of @aa:8)]→C	—	—	—	—	—	—	—	—	—	3
	B					6	Cc[-(#xx:3 of @aa:16)]→C	—	—	—	—	—	—	—	—	—	4
	B					8	Cc[-(#xx:3 of @aa:32)]→C	—	—	—	—	—	—	—	—	—	5
	B	2					Cc[-(#xx:3 of Rd8)]→C	—	—	—	—	—	—	—	—	—	1
	B	4					Cc[-(#xx:3 of @ERd24)]→C	—	—	—	—	—	—	—	—	—	3
	B					4	Cc[-(#xx:3 of @aa:8)]→C	—	—	—	—	—	—	—	—	—	3

(6) Branch Instructions

Mnemonic	Operand Size	Addressing Mode/ Instruction Length (Bytes)							Operation	Branching Condition	Condition Code					No. of States ^{*1}	
		#xx	Rn	@ERn	@(d,ERn)	@ERn/@ERn+	@aa	@(d,PC)			@aa	I	H	N	Z	V	C
Bcc	—	—	—	—	—	—	—	—	—	Always	—	—	—	—	—	—	2
BRA d:8(BT d:8)	—	—	—	—	—	—	—	—	—	if condition is true then PC←PC+d else next;	—	—	—	—	—	—	3
BRA d:16(BT d:16)	—	—	—	—	—	—	—	—	—	Never	—	—	—	—	—	—	2
BRN d:8(BF d:8)	—	—	—	—	—	—	—	—	—	C∨Z=0	—	—	—	—	—	—	3
BRN d:16(BF d:16)	—	—	—	—	—	—	—	—	—	C∨Z=1	—	—	—	—	—	—	2
BHI d:8	—	—	—	—	—	—	—	—	—	C=0	—	—	—	—	—	—	3
BHI d:16	—	—	—	—	—	—	—	—	—	C=0	—	—	—	—	—	—	2
BLS d:8	—	—	—	—	—	—	—	—	—	C=1	—	—	—	—	—	—	3
BLS d:16	—	—	—	—	—	—	—	—	—	C=1	—	—	—	—	—	—	2
BCC d:8(BHS d:8)	—	—	—	—	—	—	—	—	—	Z=0	—	—	—	—	—	—	3
BCC d:16(BHS d:16)	—	—	—	—	—	—	—	—	—	Z=0	—	—	—	—	—	—	2
BCS d:8(BLO d:8)	—	—	—	—	—	—	—	—	—	Z=1	—	—	—	—	—	—	3
BCS d:16(BLO d:16)	—	—	—	—	—	—	—	—	—	Z=1	—	—	—	—	—	—	2
BNE d:8	—	—	—	—	—	—	—	—	—	V=0	—	—	—	—	—	—	3
BNE d:16	—	—	—	—	—	—	—	—	—	V=0	—	—	—	—	—	—	2
BEQ d:8	—	—	—	—	—	—	—	—	—	V=0	—	—	—	—	—	—	3
BEQ d:16	—	—	—	—	—	—	—	—	—	V=0	—	—	—	—	—	—	2
BVC d:8	—	—	—	—	—	—	—	—	—	V=0	—	—	—	—	—	—	3
BVC d:16	—	—	—	—	—	—	—	—	—	V=0	—	—	—	—	—	—	2

Mnemonic	Operand Size	Addressing Mode/ Instruction Length (Bytes)							Operation	Condition Code					No. of States ^{*1}			
		#xx	Rn	@ERN	@d,ERN	@ERN/@ERN+	@aa	@d,PC		@aa	I	H	N	Z	V	C	Advanced	2
JMP				2					PC←ERn	—	—	—	—	—	—	2		
					4				PC←aa:24	—	—	—	—	—	3			
							2		PC←@aa:8	—	—	—	—	—	5			
BSR						2			PC→@-SP,PC←PC+d:8	—	—	—	—	—	4			
						4			PC→@-SP,PC←PC+d:16	—	—	—	—	—	5			
JSR				2					PC→@-SP,PC←ERn	—	—	—	—	—	4			
					4				PC→@-SP,PC←aa:24	—	—	—	—	—	5			
						2			PC→@-SP,PC←@aa:8	—	—	—	—	—	6			
RTS								2	PC←@SP+	—	—	—	—	—	5			

(7) System Control Instructions

Mnemonic	Operand Size	Addressing Mode/ Instruction Length (Bytes)						Operation	Condition Code					No. of States*1		
		#xx	@ERn	@(d,ERn)	@ERn/@ERn+	@aa	@(d,PC)		@aa	I	H	N	Z	V	C	Advanced
TRAPA								PC→@SP,CCR→@SP, EXR→@SP,<vector>→PC	1	—	—	—	—	—	—	8 [13]
RTE								EXR←@SP+,CCR←@SP+, PC←@SP+	↑	↑	↑	↑	↑	↑	5 [13]	
SLEEP								Transition to power-down state	—	—	—	—	—	—	2	
LDC	B	2						#xx:8→CCR	↑	↑	↑	↑	↑	↑	1	
	B	4						#xx:8→EXR	—	—	—	—	—	—	2	
	B	2						Rs8→CCR	↑	↑	↑	↑	↑	↑	1	
	B	2						Rs8→EXR	—	—	—	—	—	—	1	
	W	4						@ERs→CCR	↑	↑	↑	↑	↑	↑	3	
	W	4						@ERs→EXR	—	—	—	—	—	—	3	
	W		6					@(d:16,ERs)→CCR	↑	↑	↑	↑	↑	↑	4	
	W		6					@(d:16,ERs)→EXR	—	—	—	—	—	—	4	
	W		10					@(d:32,ERs)→CCR	↑	↑	↑	↑	↑	↑	6	
	W		10					@(d:32,ERs)→EXR	—	—	—	—	—	—	6	
	W		4					@ERs→CCR,ERs32+2→ERs32	↑	↑	↑	↑	↑	↑	4	
	W		4					@ERs→EXR,ERs32+2→ERs32	—	—	—	—	—	—	4	
	W		6					@aa:16→CCR	↑	↑	↑	↑	↑	↑	4	
	W		6					@aa:16→EXR	—	—	—	—	—	—	4	
	W		8					@aa:32→CCR	↑	↑	↑	↑	↑	↑	5	
	W		8					@aa:32→EXR	—	—	—	—	—	—	5	

Mnemonic	Operand Size	Addressing Mode/ Instruction Length (Bytes)							Operation	Condition Code					No. of States*1					
		#xx	Rn	@ERn	@ERn	@ERn/ERN	@ERn/ERN+	@aa		@aa	@aa	@aa	@aa	I		H	N	Z	V	C
STC	B	2								CCR→Rd8									1	
	B	2								EXR→Rd8									1	
	W		4							CCR→@ERd									3	
	W		4							EXR→@ERd									3	
	W			6						CCR→@(d:16,ERd)									4	
	W			6						EXR→@(d:16,ERd)									4	
	W			10						CCR→@(d:32,ERd)									6	
	W			10						EXR→@(d:32,ERd)									6	
	W			4						ERd32-2→ERd32,CCR→@ERd									4	
	W			4						ERd32-2→ERd32,EXR→@ERd									4	
ANDC	W						6			CCR→@aa:16									4	
	W						6			EXR→@aa:16									4	
	W						8			CCR→@aa:32									5	
	W						8			EXR→@aa:32									5	
	B 2									CCR, #xx:8→CCR	↑	↑	↑	↑	↓	↓			1	
ORC	B 4									EXR, #xx:8→EXR									2	
	B 2									CCR, #xx:8→CCR	↑	↑	↑	↑	↑	↑			1	
XORC	B 4									EXR, #xx:8→EXR									2	
	B 2									CCR⊕#xx:8→CCR	↑	↑	↑	↑	↑	↑			1	
NOP	B 4									EXR⊕#xx:8→EXR									2	
								2		PC←PC+2									1	

(8) Block Transfer Instructions

Mnemonic	Operand Size	Addressing Mode/ Instruction Length (Bytes)							Operation	Condition Code							No. of States*1 Advanced
		#xx	R5	@ERn	@(d,ERn)	@-ERn/@ERn+	@aa	@(d,PC)		@aa	I	H	N	Z	V	C	
EEPMOV									4	if R4L=0 Repeat @ER5→@ER6 ER5+1→ER5 ER6+1→ER6 R4L-1→R4L Until R4L=0 else next;							4+2n *2
EEPMOV.W									4	if R4≠0 Repeat @ER5→@ER6 ER5+1→ER5 ER6+1→ER6 R4-1→R4 Until R4=0 else next;							4+2n *2

Notes: 1. The number of states is the number of states required for execution when the instruction and its operands are located in on-chip memory.
2. n is the initial value of R4L or R4.

3. Only register ER0, ER1, ER4, or ER5 should be used when using the TAS instruction.

4. Only register ER0 to ER6 should be used when using the STM/LDM instruction.

[1] Seven states for saving or restoring two registers, nine states for three registers, or eleven states for four registers.

[2] Cannot be used in this LSI.

[3] Set to 1 when a carry or borrow occurs at bit 11; otherwise cleared to 0.

[4] Set to 1 when a carry or borrow occurs at bit 27; otherwise cleared to 0.

[5] Retains its previous value when the result is zero; otherwise cleared to 0.

[6] Set to 1 when the divisor is negative; otherwise cleared to 0.

[7] Set to 1 when the divisor is zero; otherwise cleared to 0.

[8] Set to 1 when the quotient is negative; otherwise cleared to 0.

[9] One additional state is required for execution when EXR is valid.

[10] IMAC instruction results are indicated in the flags when the STMAC instruction is executed.

[11] A maximum of three additional states are required for execution of one of these instructions within three states after execution of a

MAC instruction. For example, if there is a one-state instruction (such as NOP) between a MAC instruction and one of these instructions, that instruction will be two states longer.

A.2 Instruction Codes

Table A-2 shows the instruction codes.

Table A-2 Instruction Codes

Instruc- tion	Mnemonic	Size	Instruction Format																	
			1st byte	2nd byte	3rd byte	4th byte	5th byte	6th byte	7th byte	8th byte	9th byte	10th byte								
ADD	ADD.B #xx:8,Rd	B	8	rd	IMM															
	ADD.B Rs,Rd	B	0	8	rs	rd														
	ADD.W #xx:16,Rd	W	7	9	1	rd	IMM													
	ADD.W Rs,Rd	W	0	9	rs	rd														
	ADD.L #xx:32,ERd	L	7	A	1	0	erd	IMM												
ADDS	ADD.L ERs,ERd	L	0	A	1	ers	0	erd												
	ADDS #1,ERd	L	0	B	0	0	0	erd												
	ADDS #2,ERd	L	0	B	8	0	0	erd												
	ADDS #4,ERd	L	0	B	9	0	0	erd												
ADDX	ADDX #xx:8,Rd	B	9	rd	IMM															
	ADDX Rs,Rd	B	0	E	rs	rd														
AND	AND.B #xx:8,Rd	B	E	rd	IMM															
	AND.B Rs,Rd	B	1	6	rs	rd														
	AND.W #xx:16,Rd	W	7	9	6	rd	IMM													
	AND.W Rs,Rd	W	6	6	rs	rd														
	AND.L #xx:32,ERd	L	7	A	6	0	erd	IMM												
	AND.L ERs,ERd	L	0	1	F	0	0	6	6	0	ers	0	erd							
ANDC	ANDC #xx:8,CCR	B	0	6	IMM															
	ANDC #xx:8,EXR	B	0	1	4	1	0	6	IMM											
BAND	BAND #xx:3,Rd	B	7	6	0	IMM	rd													
	BAND #xx:3,@ERd	B	7	C	0	erd	0	7	6	0	IMM	0								
	BAND #xx:3,@aa:8	B	7	E	abs			7	6	0	IMM	0								
	BAND #xx:3,@aa:16	B	6	A	1	0	abs	7	6	0	IMM	0								
	BAND #xx:3,@aa:32	B	6	A	3	0	abs	7	6	0	IMM	0								
Bcc	BRA d:8 (BT d:8)	—	4	0	disp															
	BRA d:16 (BT d:16)	—	5	8	0	0	disp													
	BRN d:8 (BF d:8)	—	4	1	disp															
	BRN d:16 (BF d:16)	—	5	8	1	0	disp													

Instruc- tion	Mnemonic	Size	Instruction Format																	
			1st byte	2nd byte	3rd byte	4th byte	5th byte	6th byte	7th byte	8th byte	9th byte	10th byte								
Bcc	BHI d:8	—	4	2	disp															
	BHI d:16	—	5	8	2	0	disp													
	BLS d:8	—	4	3	disp															
	BLS d:16	—	5	8	3	0	disp													
	BCC d:8 (BHS d:8)	—	4	4	disp															
	BCC d:16 (BHS d:16)	—	5	8	4	0	disp													
	BCS d:8 (BLO d:8)	—	4	5	disp															
	BCS d:16 (BLO d:16)	—	5	8	5	0	disp													
	BNE d:8	—	4	6	disp															
	BNE d:16	—	5	8	6	0	disp													
	BEQ d:8	—	4	7	disp															
	BEQ d:16	—	5	8	7	0	disp													
	BVC d:8	—	4	8	disp															
	BVC d:16	—	5	8	8	0	disp													
	BVS d:8	—	4	9	disp															
	BVS d:16	—	5	8	9	0	disp													
	BPL d:8	—	4	A	disp															
	BPL d:16	—	5	8	A	0	disp													
	BMI d:8	—	4	B	disp															
	BMI d:16	—	5	8	B	0	disp													
BGE d:8	—	4	C	disp																
BGE d:16	—	5	8	C	0	disp														
BLT d:8	—	4	D	disp																
BLT d:16	—	5	8	D	0	disp														
BGT d:8	—	4	E	disp																
BGT d:16	—	5	8	E	0	disp														
BLE d:8	—	4	F	disp																
BLE d:16	—	5	8	F	0	disp														

Instruction	Mnemonic	Size	Instruction Format																	
			1st byte	2nd byte	3rd byte	4th byte	5th byte	6th byte	7th byte	8th byte	9th byte	10th byte								
BCLR	BCLR #xx:3,Rd	B	7	2	0:IMM; rd															
	BCLR #xx:3,@ERd	B	7	D	0:erc	0	7	2	0:IMM; 0											
	BCLR #xx:3,@aa:8	B	7	F	abs		7	2	0:IMM; 0											
	BCLR #xx:3,@aa:16	B	6	A	1	8	abs		7	2	0:IMM; 0									
	BCLR #xx:3,@aa:32	B	6	A	3	8	abs													
	BCLR Rn,Rd	B	6	2	rn	rd														
	BCLR Rn,@ERd	B	7	D	0:erc	0	6	2	rn	0										
	BCLR Rn,@aa:8	B	7	F	abs		6	2	rn	0										
BIAND	BCLR Rn,@aa:16	B	6	A	1	8	abs		6	2	rn	0								
	BCLR Rn,@aa:32	B	6	A	3	8	abs						6	2	rn	0				
	BIAND #xx:3,Rd	B	7	6	1:IMM; rd															
	BIAND #xx:3,@ERd	B	7	C	0:erc	0	7	6	1:IMM; 0											
	BIAND #xx:3,@aa:8	B	7	E	abs		7	6	1:IMM; 0											
	BIAND #xx:3,@aa:16	B	6	A	1	0	abs		7	6	1:IMM; 0									
	BIAND #xx:3,@aa:32	B	6	A	3	0	abs						7	6	1:IMM; 0					
	BILD #xx:3,Rd	B	7	7	1:IMM; rd															
BILD	BILD #xx:3,@ERd	B	7	C	0:erc	0	7	7	1:IMM; 0											
	BILD #xx:3,@aa:8	B	7	E	abs		7	7	1:IMM; 0											
	BILD #xx:3,@aa:16	B	6	A	1	0	abs		7	7	1:IMM; 0									
	BILD #xx:3,@aa:32	B	6	A	3	0	abs						7	7	1:IMM; 0					
	BIOR #xx:3,Rd	B	7	4	1:IMM; rd															
	BIOR #xx:3,@ERd	B	7	C	0:erc	0	7	4	1:IMM; 0											
	BIOR #xx:3,@aa:8	B	7	E	abs		7	4	1:IMM; 0											
	BIOR #xx:3,@aa:16	B	6	A	1	0	abs		7	4	1:IMM; 0									
BIOR #xx:3,@aa:32	B	6	A	3	0	abs							7	4	1:IMM; 0					

Instruc- tion	Mnemonic	Size	Instruction Format																	
			1st byte	2nd byte	3rd byte	4th byte	5th byte	6th byte	7th byte	8th byte	9th byte	10th byte								
BIST	BIST #xx:3,Rd	B	6	7	1:IMM; rd															
	BIST #xx:3,@ERd	B	7	D	0; erd	0	6	7	1:IMM; 0											
	BIST #xx:3,@aa:8	B	7	F	abs		6	7	1:IMM; 0											
	BIST #xx:3,@aa:16	B	6	A	1	8			abs	6	7	1:IMM; 0								
	BIST #xx:3,@aa:32	B	6	A	3	8			abs											
BIXOR	BIXOR #xx:3,Rd	B	7	5	1:IMM; rd															
	BIXOR #xx:3,@ERd	B	7	C	0; erd	0	7	5	1:IMM; 0											
	BIXOR #xx:3,@aa:8	B	7	E	abs		7	5	1:IMM; 0											
	BIXOR #xx:3,@aa:16	B	6	A	1	0			abs	7	5	1:IMM; 0								
	BIXOR #xx:3,@aa:32	B	6	A	3	0			abs											
BLD	BLD #xx:3,Rd	B	7	7	0:IMM; rd															
	BLD #xx:3,@ERd	B	7	C	0; erd	0	7	7	0:IMM; 0											
	BLD #xx:3,@aa:8	B	7	E	abs		7	7	0:IMM; 0											
	BLD #xx:3,@aa:16	B	6	A	1	0			abs	7	7	0:IMM; 0								
	BLD #xx:3,@aa:32	B	6	A	3	0			abs											
BNOT	BNOT #xx:3,Rd	B	7	1	0:IMM; rd															
	BNOT #xx:3,@ERd	B	7	D	0; erd	0	7	1	0:IMM; 0											
	BNOT #xx:3,@aa:8	B	7	F	abs		7	1	0:IMM; 0											
	BNOT #xx:3,@aa:16	B	6	A	1	8			abs	7	1	0:IMM; 0								
	BNOT #xx:3,@aa:32	B	6	A	3	8			abs											
	BNOT Rn,Rd	B	6	1	rn	rd														
	BNOT Rn,@ERd	B	7	D	0; erd	0	6	1	rn	0										
	BNOT Rn,@aa:8	B	7	F	abs		6	1	rn	0										
BNOT Rn,@aa:16	B	6	A	1	8			abs	6	1	rn	0								
BNOT Rn,@aa:32	B	6	A	3	8			abs												

Instruction	Mnemonic	Size	Instruction Format																	
			1st byte	2nd byte	3rd byte	4th byte	5th byte	6th byte	7th byte	8th byte	9th byte	10th byte								
BOR	BOR #xx:3,Rd	B	7	4	0:IMM; rd															
	BOR #xx:3,@ERd	B	7	C	0:erc	0	7	4	0:IMM; 0											
	BOR #xx:3,@aa:8	B	7	E	abs		7	4	0:IMM; 0											
	BOR #xx:3,@aa:16	B	6	A	1	0	abs		7	4	0:IMM; 0									
	BOR #xx:3,@aa:32	B	6	A	3	0	abs													
	BSET #xx:3,Rd	B	7	0	0:IMM; rd															
BSET	BSET #xx:3,@ERd	B	7	D	0:erc	0	7	0	0:IMM; 0											
	BSET #xx:3,@aa:8	B	7	F	abs		7	0	0:IMM; 0											
	BSET #xx:3,@aa:16	B	6	A	1	8	abs		7	0	0:IMM; 0									
	BSET #xx:3,@aa:32	B	6	A	3	8	abs													
	BSET Rn,Rd	B	6	0	rn	rd														
	BSET Rn,@ERd	B	7	D	0:erc	0	6	0	rn	0										
BSET Rn,@aa:8	BSET Rn,@aa:8	B	7	F	abs		6	0	rn	0										
	BSET Rn,@aa:16	B	6	A	1	8	abs		6	0	rn	0								
	BSET Rn,@aa:32	B	6	A	3	8	abs													
	BSR d:8	—	5	5	disp															
	BSR d:16	—	5	C	0	0	disp													
	BST	BST #xx:3,Rd	B	6	7	0:IMM; rd														
BST #xx:3,@ERd		B	7	D	0:erc	0	6	7	0:IMM; 0											
BST #xx:3,@aa:8		B	7	F	abs		6	7	0:IMM; 0											
BST #xx:3,@aa:16		B	6	A	1	8	abs		6	7	0:IMM; 0									
BST #xx:3,@aa:32		B	6	A	3	8	abs													
BTST #xx:3,Rd		B	7	3	0:IMM; rd															
BTST	BTST #xx:3,@ERd	B	7	C	0:erc	0	7	3	0:IMM; 0											
	BTST #xx:3,@aa:8	B	7	E	abs		7	3	0:IMM; 0											
	BTST #xx:3,@aa:16	B	6	A	1	0	abs		7	3	0:IMM; 0									
	BTST #xx:3,@aa:32	B	6	A	3	0	abs													
	BTST Rn,Rd	B	6	3	rn	rd														
	BTST Rn,@ERd	B	7	C	0:erc	0	6	3	rn	0										

Instruction	Mnemonic	Size	Instruction Format																	
			1st byte	2nd byte	3rd byte	4th byte	5th byte	6th byte	7th byte	8th byte	9th byte	10th byte								
BTST	BTST Rn,@aa:8	B	7	E	abs	6	3	m	0											
	BTST Rn,@aa:16	B	6	A	1	0	abs	6	3	m	0									
	BTST Rn,@aa:32	B	6	A	3	0	abs													
BXOR	BXOR #xx:3,Rd	B	7	5	0:IMM; rd															
	BXOR #xx:3,@ERd	B	7	C	0:erd	0	7	5	0:IMM; 0											
	BXOR #xx:3,@aa:8	B	7	E	abs	7	5	0:IMM; 0												
	BXOR #xx:3,@aa:16	B	6	A	1	0	abs	7	5	0:IMM; 0										
BXOR #xx:3,@aa:32	B	6	A	3	0	abs														
CLRMAC	CLRMAC	—	0	1	A	0														
CMP	CMP.B #xx:8,Rd	B	A	rd	IMM															
	CMP.B Rs,Rd	B	1	C	rs	rd														
	CMP.W #xx:16,Rd	W	7	9	2	rd	IMM													
	CMP.W Rs,Rd	W	1	D	rs	rd														
	CMP.L #xx:32,ERd	L	7	A	2	0:erd														
	CMP.L ERs,ERd	L	1	F	1:ers	0:erd														
DAA	DAA Rd	B	0	F	0	rd														
DAS	DAS Rd	B	1	F	0	rd														
DEC	DEC.B Rd	B	1	A	0	rd														
	DEC.W #1,Rd	W	1	B	5	rd														
	DEC.W #2,Rd	W	1	B	D	rd														
	DEC.L #1,ERd	L	1	B	7	0:erd														
	DEC.L #2,ERd	L	1	B	F	0:erd														
DIVXS	DIVXS.B Rs,Rd	B	0	1	D	0	5	1	rs	rd										
	DIVXS.W Rs,ERd	W	0	1	D	0	5	3	rs	0:erd										
DIVXU	DIVXU.B Rs,Rd	B	5	1	rs	rd														
	DIVXU.W Rs,ERd	W	5	3	rs	0:erd														
EEMOV	EEMOV.B	—	7	B	5	C	5	9	8	F										
	EEMOV.W	—	7	B	D	4	5	9	8	F										

Instruction	Mnemonic	Size	Instruction Format																				
			1st byte	2nd byte	3rd byte	4th byte	5th byte	6th byte	7th byte	8th byte	9th byte	10th byte											
EXTS	EXTS.W,Rd	W	1	7	D	rd																	
	EXTS.L,ERd	L	1	7	F	0:erd																	
EXTU	EXTU.W,Rd	W	1	7	5	rd																	
	EXTU.L,ERd	L	1	7	7	0:erd																	
INC	INC.B,Rd	B	0	A	0	rd																	
	INC.W #1,Rd	W	0	B	5	rd																	
	INC.W #2,Rd	W	0	B	D	rd																	
	INC.L #1,ERd	L	0	B	7	0:erd																	
	INC.L #2,ERd	L	0	B	F	0:erd																	
JMP	JMP @ERn	—	5	9	0:ern	0																	
	JMP @aa:24	—	5	A		abs																	
	JMP @:aa:8	—	5	B	abs																		
JSR	JSR @ERn	—	5	D	0:ern	0																	
	JSR @aa:24	—	5	E		abs																	
	JSR @:aa:8	—	5	F	abs																		
LDC	LDC #xx:8,CCR	B	0	7	IMM																		
	LDC #xx:8,EXR	B	0	1	4	1	0	7	IMM														
	LDC Rs,CCR	B	0	3	0	rs																	
	LDC Rs,EXR	B	0	3	1	rs																	
	LDC @ERs,CCR	W	0	1	4	0	6	9	0:ers	0													
	LDC @ERs,EXR	W	0	1	4	1	6	9	0:ers	0													
	LDC @(d:16,ERs),CCR	W	0	1	4	0	6	F	0:ers	0					disp								
	LDC @(d:16,ERs),EXR	W	0	1	4	1	6	F	0:ers	0					disp								
LDC @(d:32,ERs),CCR	W	0	1	4	0	7	8	0:ers	0	6	B	2	0										
LDC @(d:32,ERs),EXR	W	0	1	4	1	7	8	0:ers	0	6	B	2	0										
LDC @ERs+,CCR	W	0	1	4	0	6	D	0:ers	0														
LDC @ERs+,EXR	W	0	1	4	1	6	D	0:ers	0														
LDC @aa:16,CCR	W	0	1	4	0	6	B	0	0					abs									
LDC @aa:16,EXR	W	0	1	4	1	6	B	0	0					abs									

Instruction	Mnemonic	Size	Instruction Format											
			1st byte	2nd byte	3rd byte	4th byte	5th byte	6th byte	7th byte	8th byte	9th byte	10th byte		
LDC	LDC @aa:32,CCR	W	0	1	4	0	6	B	2	0	abs			
	LDC @aa:32,EXR	W	0	1	4	1	6	B	2	0	abs			
LDM*3	LDM.L @SP+, (ERn-ERn+1)	L	0	1	1	0	6	D	7	0:erm+1				
	LDM.L @SP+, (ERn-ERn+2)	L	0	1	2	0	6	D	7	0:erm+2				
	LDM.L @SP+, (ERn-ERn+3)	L	0	1	3	0	6	D	7	0:erm+3				
LDMAC	LDMAC ERs,MACH	L	0	3	2	0:ers								
	LDMAC ERs,MACL	L	0	3	3	0:ers								
MAC	MAC @ERn+:@ERm+	—	0	1	6	0	6	D	0:ern	0:erm				
MOV	MOV.B #xx:8,Rd	B	F	rd	IMM									
	MOV.B Rs,Rd	B	0	C	rs	rd								
	MOV.B @ERs,Rd	B	6	8	0:ers	rd								
	MOV.B @(d:16,ERs),Rd	B	6	E	0:ers	rd	disp							
	MOV.B @(d:32,ERs),Rd	B	7	8	0:ers	0	6	A	2	rd	disp			
	MOV.B @ERs+,Rd	B	6	C	0:ers	rd								
	MOV.B @aa:8,Rd	B	2	rd	abs									
	MOV.B @aa:16,Rd	B	6	A	0	rd	abs							
	MOV.B @aa:32,Rd	B	6	A	2	rd	abs							
	MOV.B Rs,@ERd	B	6	8	1:erd	rs								
	MOV.B Rs @(d:16,ERd)	B	6	E	1:erd	rs	disp							
	MOV.B Rs @(d:32,ERd)	B	7	8	0:erd	0	6	A	A	rs	disp			
	MOV.B Rs,@-ERd	B	6	C	1:erd	rs								
	MOV.B Rs,@aa:8	B	3	rs	abs									
	MOV.B Rs,@aa:16	B	6	A	8	rs	abs							
MOV.B Rs,@aa:32	B	6	A	A	rs	abs								
MOV.W #xx:16,Rd	W	7	9	0	rd	IMM								
MOV.W Rs,Rd	W	0	D	rs	rd									
MOV.W @ERs,Rd	W	6	9	0:ers	rd									
MOV.W @(d:16,ERs),Rd	W	6	F	0:ers	rd	disp								
MOV.W @(d:32,ERs),Rd	W	7	8	0:ers	0	6	B	2	rd	disp				

Instruction	Mnemonic	Size	Instruction Format															
			1st byte	2nd byte	3rd byte	4th byte	5th byte	6th byte	7th byte	8th byte	9th byte	10th byte						
MOV	MOV.W @ERs+, Rd	W	6	D	0:ers	rd												
	MOV.W @aa:16, Rd	W	6	B	0	rd	abs											
	MOV.W @aa:32, Rd	W	6	B	2	rd	abs											
	MOV.W Rs, @ERd	W	6	9	1:erd	rs												
	MOV.W Rs, @(d:16, ERd)	W	6	F	1:erd	rs	disp											
	MOV.W Rs, @(d:32, ERd)	W	7	8	0:erd	0	6	B	A	rs	disp							
	MOV.W Rs, @ERd	W	6	D	1:erd	rs												
	MOV.W Rs, @aa:16	W	6	B	8	rs	abs											
	MOV.W Rs, @aa:32	W	6	B	A	rs	abs											
	MOV.L #xx:32, Rd	L	7	A	0	0:erd												
	MOV.L ERs, ERd	L	0	F	1:ers	0:erd												
	MOV.L @ERs, ERd	L	0	1	0	0	6	9	0:ers	0:erd								
	MOV.L @(d:16, ERs), ERd	L	0	1	0	0	6	F	0:ers	0:erd	disp							
	MOV.L @(d:32, ERs), ERd	L	0	1	0	0	7	8	0:ers	0	6	B	2	0:erd	disp			
	MOV.L @ERs+, ERd	L	0	1	0	0	6	D	0:ers	0:erd								
	MOV.L @aa:16, ERd	L	0	1	0	0	6	B	0	0:erd	abs							
	MOV.L @aa:32, ERd	L	0	1	0	0	6	B	2	0:erd	abs							
MOV.L ERs, @ERd	L	0	1	0	0	6	9	1:erd	0:ers									
MOV.L ERs, @(d:16, ERd)	L	0	1	0	0	6	F	1:erd	0:ers	disp								
MOV.L ERs, @(d:32, ERd)*1	L	0	1	0	0	7	8	0:erd	0	6	B	A	0:ers	disp				
MOV.L ERs, @ERd	L	0	1	0	0	6	D	1:erd	0:ers									
MOV.L ERs, @aa:16	L	0	1	0	0	6	B	8	0:ers	abs								
MOV.L ERs, @aa:32	L	0	1	0	0	6	B	A	0:ers	abs								
MOVFPPE @aa:16, Rd	B	Cannot be used in this LSI																
MOVTPPE	MOVTPPE Rs, @aa:16	B																
MULXS	MULXS.B Rs, Rd	B	0	1	C	0	5	0	rs	rd								
	MULXS.W Rs, ERd	W	0	1	C	0	5	2	rs	0:erd								
MULXU	MULXU.B Rs, Rd	B	5	0	rs	rd												
	MULXU.W Rs, ERd	W	5	2	rs	0:erd												



Instruc- tion	Mnemonic	Size	Instruction Format																	
			1st byte	2nd byte	3rd byte	4th byte	5th byte	6th byte	7th byte	8th byte	9th byte	10th byte								
NEG	NEG.B Rd	B	1	7	8	rd														
	NEG.W Rd	W	1	7	9	rd														
	NEG.L ERd	L	1	7	B	0:erd														
NOP	NOP	—	0	0	0	0														
NOT	NOT.B Rd	B	1	7	0	rd														
	NOT.W Rd	W	1	7	1	rd														
	NOT.L ERd	L	1	7	3	0:erd														
OR	OR.B #xx:8,Rd	B	C	rd	IMM															
	OR.B Rs,Rd	B	1	4	rs	rd														
	OR.W #xx:16,Rd	W	7	9	4	rd	IMM													
	OR.W Rs,Rd	W	6	4	rs	rd														
	OR.L #xx:32,ERd	L	7	A	4	0:erd														
	OR.L ERs,ERd	L	0	1	F	0			6	4	0	ers	0:erd							
ORC	ORC #xx:8,CCR	B	0	4	IMM															
	ORC #xx:8,EXR	B	0	1	4	1	0	4	IMM											
POP	POP.W Rn	W	6	D	7	rn														
	POP.L ERn	L	0	1	0	0		6	D	7	0:em									
PUSH	PUSH.W Rn	W	6	D	F	rn														
	PUSH.L ERn	L	0	1	0	0		6	D	F	0:em									
ROTL	ROTL.B Rd	B	1	2	8	rd														
	ROTL.B #2, Rd	B	1	2	C	rd														
	ROTL.W Rd	W	1	2	9	rd														
	ROTL.W #2, Rd	W	1	2	D	rd														
	ROTL.L ERd	L	1	2	B	0:erd														
ROTL.L #2, ERd	L	1	2	F	0:erd															

Instruction	Mnemonic	Size	Instruction Format																	
			1st byte	2nd byte	3rd byte	4th byte	5th byte	6th byte	7th byte	8th byte	9th byte	10th byte								
ROTR	ROTR.B Rd	B	1	3	8	rd														
	ROTR.B #2, Rd	B	1	3	C	rd														
	ROTR.W Rd	W	1	3	9	rd														
	ROTR.W #2, Rd	W	1	3	D	rd														
	ROTR.L ERd	L	1	3	B	0:erd														
	ROTR.L #2, ERd	L	1	3	F	0:erd														
ROTXL	ROTXL.B Rd	B	1	2	0	rd														
	ROTXL.B #2, Rd	B	1	2	4	rd														
	ROTXL.W Rd	W	1	2	1	rd														
	ROTXL.W #2, Rd	W	1	2	5	rd														
	ROTXL.L ERd	L	1	2	3	0:erd														
	ROTXL.L #2, ERd	L	1	2	7	0:erd														
ROTXR	ROTXR.B Rd	B	1	3	0	rd														
	ROTXR.B #2, Rd	B	1	3	4	rd														
	ROTXR.W Rd	W	1	3	1	rd														
	ROTXR.W #2, Rd	W	1	3	5	rd														
	ROTXR.L ERd	L	1	3	3	0:erd														
	ROTXR.L #2, ERd	L	1	3	7	0:erd														
RTE	RTE	—	5	6	7	0														
RTS	RTS	—	5	4	7	0														
SHAL	SHAL.B Rd	B	1	0	8	rd														
	SHAL.B #2, Rd	B	1	0	C	rd														
	SHAL.W Rd	W	1	0	9	rd														
	SHAL.W #2, Rd	W	1	0	D	rd														
	SHAL.L ERd	L	1	0	B	0:erd														
	SHAL.L #2, ERd	L	1	0	F	0:erd														

Instruc- tion	Mnemonic	Size	Instruction Format																	
			1st byte	2nd byte	3rd byte	4th byte	5th byte	6th byte	7th byte	8th byte	9th byte	10th byte								
SHAR	SHAR.B Rd	B	1	1	8	rd														
	SHAR.B #2, Rd	B	1	1	C	rd														
	SHAR.W Rd	W	1	1	9	rd														
	SHAR.W #2, Rd	W	1	1	D	rd														
	SHAR.L ERd	L	1	1	B	0: erd														
	SHAR.L #2, ERd	L	1	1	F	0: erd														
SHLL	SHLL.B Rd	B	1	0	0	rd														
	SHLL.B #2, Rd	B	1	0	4	rd														
	SHLL.W Rd	W	1	0	1	rd														
	SHLL.W #2, Rd	W	1	0	5	rd														
	SHLL.L ERd	L	1	0	3	0: erd														
	SHLL.L #2, ERd	L	1	0	7	0: erd														
SHLR	SHLR.B Rd	B	1	1	0	rd														
	SHLR.B #2, Rd	B	1	1	4	rd														
	SHLR.W Rd	W	1	1	1	rd														
	SHLR.W #2, Rd	W	1	1	5	rd														
	SHLR.L ERd	L	1	1	3	0: erd														
	SHLR.L #2, ERd	L	1	1	7	0: erd														
SLEEP	SLEEP	—	0	1	8	0														
STC	STC.B CCR,Rd	B	0	2	0	rd														
	STC.B EXR,Rd	B	0	2	1	rd														
	STC.W CCR,@ERd	W	0	1	4	0	6	9	1	erd	0									
	STC.W EXR,@ERd	W	0	1	4	1	6	9	1	erd	0									
	STC.W CCR,@(d:16,ERd)	W	0	1	4	0	6	F	1	erd	0									
	STC.W EXR,@(d:16,ERd)	W	0	1	4	1	6	F	1	erd	0									
	STC.W CCR,@(d:32,ERd)	W	0	1	4	0	7	8	0	erd	0	6	B	A	0					
	STC.W EXR,@(d:32,ERd)	W	0	1	4	1	7	8	0	erd	0	6	B	A	0					
	STC.W CCR,@-ERd	W	0	1	4	0	6	D	1	erd	0									
	STC.W EXR,@-ERd	W	0	1	4	1	6	D	1	erd	0									

Instruction	Mnemonic	Size	Instruction Format													
			1st byte	2nd byte	3rd byte	4th byte	5th byte	6th byte	7th byte	8th byte	9th byte	10th byte				
STC	STC.W CCR,@aa:16	W	0	1	4	0	6	B	8	0	abs					
	STC.W EXR,@aa:16	W	0	1	4	1	6	B	8	0	abs					
	STC.W CCR,@aa:32	W	0	1	4	0	6	B	A	0	abs					
	STC.W EXR,@aa:32	W	0	1	4	1	6	B	A	0	abs					
STM*3	STM.L(ERn+ERn+1),@-SP	L	0	1	1	0	6	D	F	0:em						
	STM.L(ERn+ERn+2),@-SP	L	0	1	2	0	6	D	F	0:em						
	STM.L(ERn+ERn+3),@-SP	L	0	1	3	0	6	D	F	0:em						
	STMAC MACH,ERd	L	0	2	2	0:ers										
STMAC	STMAC MACL,ERd	L	0	2	3	0:ers										
	SUB.B Rs,Rd	B	1	8	rs	rd										
SUB	SUB.W #xx:16,Rd	W	7	9	3	rd		IMM								
	SUB.W Rs,Rd	W	1	9	rs	rd										
	SUB.L #xx:32,ERd	L	7	A	3	0:erd			IMM							
	SUB.L ERs,ERd	L	1	A	1:ers	0:erd										
	SUBS #1,ERd	L	1	B	0	0:erd										
	SUBS #2,ERd	L	1	B	8	0:erd										
SUBX	SUBS #4,ERd	L	1	B	9	0:erd										
	SUBX #xx:8,Rd	B	B	rd	IMM											
TAS	SUBX Rs,Rd	B	1	E	rs	rd										
	TAS @ERd*2	B	0	1	E	0	7	B	0:erd	C						
TRAPA	TRAPA #x:2	—	5	7	00:IMM	0										
XOR	XOR.B #xx:8,Rd	B	D	rd	IMM											
	XOR.B Rs,Rd	B	1	5	rs	rd										
	XOR.W #xx:16,Rd	W	7	9	5	rd		IMM								
	XOR.W Rs,Rd	W	6	5	rs	rd										
	XOR.L #xx:32,ERd	L	7	A	5	0:erd			IMM							
	XOR.L ERs,ERd	L	0	1	F	0	6	5	0:ers	0:erd						

Instruc- tion	Mnemonic	Size	Instruction Format													
			1st byte	2nd byte	3rd byte	4th byte	5th byte	6th byte	7th byte	8th byte	9th byte	10th byte				
XORC	XORC #xx:8,CCR	B	0	5	IMM											
	XORC #xx:8,EXR	B	0	1	4	1	0	5	IMM							

- Notes: 1. Bit 7 of the 4th byte of the MOV.L ERs, @(d:32.ERd) instruction can be either 1 or 0.
 2. Only register ER0, ER1, ER4, or ER5 should be used when using the TAS instruction.
 3. Only register ER0 to ER6 should be used when using the STM/LDM instruction.

Legend:

- IMM: Immediate data (2, 3, 8, 16, or 32 bits)
 abs: Absolute address (8, 16, 24, or 32 bits)
 disp: Displacement (8, 16, or 32 bits)
 rs, rd, rn: Register field (4 bits specifying an 8-bit or 16-bit register. The symbols rs, rd, and rn correspond to operand symbols Rs, Rd, and Rn)
 ers, erd, erm, erm: Register field (3 bits specifying an address register or 32-bit register. The symbols ers, erd, erm, and erm correspond to operand symbols ERs, ERd, ERn, and ERm)

The register fields specify general registers as follows.

Address Register		16-Bit Register		8-Bit Register	
32-Bit Register	General Register	Register Field	General Register	Register Field	General Register
000	ER0	0000	R0	0000	R0H
001	ER1	0001	R1	0001	R1H
.
.
111	ER7	0111	R7	0111	R7H
		1000	E0	1000	R0L
		1001	E1	1001	R1L
	
	
	
		1111	E7	1111	R7L

A.3 Operation Code Map

Table A-3 shows the operation code map.

Table A-3 Operation Code Map (1)

Instruction code		1st byte		2nd byte																		
		AH	AL	BH	BL	0	1	2	3	4	5	6	7	8	9	A	B	C	D	E	F	
0	NOP	Table A.3(2)	STC	LDC	ORC	XORC	ANDC	LDC	Table A.3(2)	ADD	Table A.3(2)	Table A.3(2)	Table A.3(2)	Table A.3(2)	Table A.3(2)	Table A.3(2)	Table A.3(2)	Table A.3(2)	Table A.3(2)	Table A.3(2)	Table A.3(2)	Table A.3(2)
1	Table A.3(2)	Table A.3(2)	STMAC	LDMAC	OR	XOR	AND	Table A.3(2)	Table A.3(2)	SUB	Table A.3(2)	Table A.3(2)	Table A.3(2)	Table A.3(2)	Table A.3(2)	Table A.3(2)	Table A.3(2)	Table A.3(2)	Table A.3(2)	Table A.3(2)	Table A.3(2)	Table A.3(2)
2	MOV/B																					
3	MOV/B																					
4	BRA	BRN	BHI	BLS	BCC	BCS	BNE	BEQ	BVC	BVS	BPL	BMI	BGE	BLT	BGT	BLE						
5	MULXU	DIVXU	MULXU	DIVXU	RTS	BSR	RTE	TRAPA	Table A.3(2)	JMP	JMP											
6	BSET	BNOT	BCLR	BTST	OR	XOR	AND	BST	MOV	Table A.3(2)												
7					BOR	BXOR	BAND	BLD	BIST	MOV	Table A.3(2)	EEMOV										
8	ADD																					
9	ADDX																					
A	CMP																					
B	SUBX																					
C	OR																					
D	XOR																					
E	AND																					
F	MOV																					

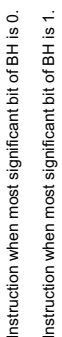

Table A-3 Operation Code Map (2)

Instruction code		1st byte		2nd byte																	
		AH	AL	BH	BL																
BH/AH	0	1	2	3	4	5	6	7	8	9	A	B	C	D	E	F					
01	MOV	LDM	STM	LDC	STC		MAC		SLEEP		CLRMAC		Table A.3(3)	Table A.3(3)	TAS	Table A.3(3)					
0A	INC	ADD																			
0B	ADDS					INC		INC	ADDS					INC		INC					
0F	DAA	MOV																			
10	SHLL				SHLL			SHLL	SHAL				SHAL			SHAL					
11	SHLR				SHLR			SHLR	SHAR				SHAR			SHAR					
12	ROTXL				ROTXL			ROTXL	ROTL				ROTL			ROTL					
13	ROTXR				ROTXR			ROTXR	ROTR				ROTR			ROTR					
17	NOT		NOT			EXTU		EXTU	NEG			NEG		EXTS		EXTS					
1A	DEC	SUB																			
1B	SUBS					DEC		DEC	SUBS				DEC			DEC					
1F	DAS	CMP																			
58	BRA	BRN	BHI	BLS	BCC	BCS	BNE	BEQ	BVC	BVS	BPL	BMI	BGE	BLT	BGT	BLE					
6A	MOV	Table A.3(4)	MOV	Table A.3(4)	MOVFPPE*				MOV		MOV		MOVFPPE*								
79	MOV	ADD	CMP	SUB	OR	XOR	AND														
7A	MOV	ADD	CMP	SUB	OR	XOR	AND														

Note: * Cannot be used in this LSI.

Table A-3 Operation Code Map (3)

Instruction code	1st byte		2nd byte		3rd byte		4th byte	
	AH	AL	BH	BL	CH	CL	DH	DL

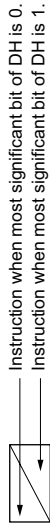

	0	1	2	3	4	5	6	7	8	9	A	B	C	D	E	F
AH\AL																
BH\BL																
CH																
CL																
01C05	MULXS		MULXS													
01D05		DIVXS		DIVXS												
01F06					OR	XOR	AND									
7Cr06 *1				BTST												
7Cr07 *1				BTST	BOR	BXOR	BAND	BLD								
					BIOR	BIXOR	BIAND	BILD								
7Dr06 *1	BSET	BNOT	BCLR					BST								
7Dr07 *1	BSET	BNOT	BCLR													
7Eaa6 *2				BTST												
7Eaa7 *2				BTST	BOR	BXOR	BAND	BLD								
					BIOR	BIXOR	BIAND	BILD								
7Faa6 *2	BSET	BNOT	BCLR					BST								
7Faa7 *2	BSET	BNOT	BCLR													

Notes: 1. r is the register specification field.
 2. aa is the absolute address specification.

Table A-3 Operation Code Map (4)

Instruction code		1st byte		2nd byte		3rd byte		4th byte		5th byte		6th byte	
AH	AL	BH	BL	CH	CL	DH	DL	EH	EL	FH	FL		

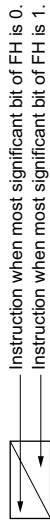

EL AH/AL/BH/BL/CH/CL/DH/DL/EH/EL/FH/FL	0	1	2	3	4	5	6	7	8	9	A	B	C	D	E	F
6A10aaaa6*				BTST												
6A10aaaa7*					BOR BIXOR	BAND BIAND		BLD BILD								
6A18aaaa6*								BST								
6A18aaaa7*								BIST								
	BSET	BNOT	BCLR													

Instruction code		1st byte		2nd byte		3rd byte		4th byte		5th byte		6th byte		7th byte		8th byte	
AH	AL	BH	BL	CH	CL	DH	DL	EH	EL	FH	FL	GH	GL	HH	HL		

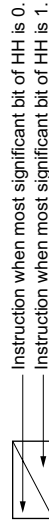

GL AH/AL/BH/BL/CH/CL/DH/DL/EH/EL/FH/FL/HH/HL	0	1	2	3	4	5	6	7	8	9	A	B	C	D	E	F
6A30aaaaaaa6*				BTST												
6A30aaaaaaa7*					BOR BIXOR	BAND BIAND		BLD BILD								
6A38aaaaaaa6*								BST								
6A38aaaaaaa7*								BIST								
	BSET	BNOT	BCLR													

Note: * aa is the absolute address specification.

A.4 Number of States Required for Instruction Execution

The tables in this section can be used to calculate the number of states required for instruction execution by the CPU. Table A-5 indicates the number of instruction fetch, data read/write, and other cycles occurring in each instruction. Table A-4 indicates the number of states required for each cycle. The number of states required for execution of an instruction can be calculated from these two tables as follows:

$$\text{Execution states} = I \times S_I + J \times S_J + K \times S_K + L \times S_L + M \times S_M + N \times S_N$$

Examples: Advanced mode, program code and stack located in external memory, on-chip supporting modules accessed in two states with 8-bit bus width, external devices accessed in three states with one wait state and 16-bit bus width.

1. BSET #0, @FFFFC7:8

From table A-5:

$$I = L = 2, \quad J = K = M = N = 0$$

From table A-4:

$$S_I = 4, \quad S_L = 2$$

$$\text{Number of states required for execution} = 2 \times 4 + 2 \times 2 = 12$$

2. JSR @@30

From table A-5:

$$I = J = K = 2, \quad L = M = N = 0$$

From table A-4:

$$S_I = S_J = S_K = 4$$

$$\text{Number of states required for execution} = 2 \times 4 + 2 \times 4 + 2 \times 4 = 24$$

Table A-4 Number of States per Cycle

Cycle		On-Chip Memory	Access Conditions					
			On-Chip Supporting Module		External Device			
			8-Bit Bus	16-Bit Bus	8-Bit Bus		16-Bit Bus	
				2-State Access	3-State Access	2-State Access	3-State Access	
Instruction fetch	S _I	1	4	2	4	6 + 2m	2	3 + m
Branch address read	S _J							
Stack operation	S _K							
Byte data access	S _L		2		2	3 + m		
Word data access	S _M		4		4	6 + 2m		
Internal operation	S _N	1	1	1	1	1	1	1

Legend:

m: Number of wait states inserted into external device access

Table A-5 Number of Cycles in Instruction Execution

Instruction	Mnemonic	Instruction	Branch	Stack	Byte	Word	Internal
		Fetch	Address	Operation	Data	Data	Operation
		I	J	K	L	M	N
ADD	ADD.B #xx:8,Rd	1					
	ADD.B Rs,Rd	1					
	ADD.W #xx:16,Rd	2					
	ADD.W Rs,Rd	1					
	ADD.L #xx:32,ERd	3					
	ADD.L ERs,ERd	1					
ADDS	ADDS #1/2/4,ERd	1					
ADDX	ADDX #xx:8,Rd	1					
	ADDX Rs,Rd	1					
AND	AND.B #xx:8,Rd	1					
	AND.B Rs,Rd	1					
	AND.W #xx:16,Rd	2					
	AND.W Rs,Rd	1					
	AND.L #xx:32,ERd	3					
	AND.L ERs,ERd	2					
ANDC	ANDC #xx:8,CCR	1					
	ANDC #xx:8,EXR	2					
BAND	BAND #xx:3,Rd	1					
	BAND #xx:3,@ERd	2			1		
	BAND #xx:3,@aa:8	2			1		
	BAND #xx:3,@aa:16	3			1		
	BAND #xx:3,@aa:32	4			1		
Bcc	BRA d:8 (BT d:8)	2					
	BRN d:8 (BF d:8)	2					
	BHI d:8	2					
	BLS d:8	2					
	BCC d:8 (BHS d:8)	2					
	BCS d:8 (BLO d:8)	2					
	BNE d:8	2					
	BEQ d:8	2					
	BVC d:8	2					

Instruction	Mnemonic	Instruction	Branch	Stack	Byte	Word	Internal	
		Fetch	Address		Data	Data		Operation
		I	J	K	L	M	N	
Bcc	BVS d:8	2						
	BPL d:8	2						
	BMI d:8	2						
	BGE d:8	2						
	BLT d:8	2						
	BGT d:8	2						
	BLE d:8	2						
	BRA d:16 (BT d:16)	2						1
	BRN d:16 (BF d:16)	2						1
	BHI d:16	2						1
	BLS d:16	2						1
	BCC d:16 (BHS d:16)	2						1
	BCS d:16 (BLO d:16)	2						1
	BNE d:16	2						1
	BEQ d:16	2						1
	BVC d:16	2						1
	BVS d:16	2						1
	BPL d:16	2						1
	BMI d:16	2						1
	BGE d:16	2						1
BLT d:16	2						1	
BGT d:16	2						1	
BLE d:16	2						1	
BCLR	BCLR #xx:3,Rd	1						
	BCLR #xx:3,@ERd	2			2			
	BCLR #xx:3,@aa:8	2			2			
	BCLR #xx:3,@aa:16	3			2			
	BCLR #xx:3,@aa:32	4			2			
	BCLR Rn,Rd	1						
	BCLR Rn,@ERd	2			2			
	BCLR Rn,@aa:8	2			2			
	BCLR Rn,@aa:16	3			2			
	BCLR Rn,@aa:32	4			2			

Instruction	Mnemonic	Instruction	Branch	Stack	Byte	Word	Internal
		Fetch	Address	Operation	Data	Data	Operation
		I	J	K	L	M	N
BIAND	BIAND #xx:3,Rd	1					
	BIAND #xx:3,@ERd	2			1		
	BIAND #xx:3,@aa:8	2			1		
	BIAND #xx:3,@aa:16	3			1		
	BIAND #xx:3,@aa:32	4			1		
BILD	BILD #xx:3,Rd	1					
	BILD #xx:3,@ERd	2			1		
	BILD #xx:3,@aa:8	2			1		
	BILD #xx:3,@aa:16	3			1		
	BILD #xx:3,@aa:32	4			1		
BIOR	BIOR #xx:8,Rd	1					
	BIOR #xx:8,@ERd	2			1		
	BIOR #xx:8,@aa:8	2			1		
	BIOR #xx:8,@aa:16	3			1		
	BIOR #xx:8,@aa:32	4			1		
BIST	BIST #xx:3,Rd	1					
	BIST #xx:3,@ERd	2			2		
	BIST #xx:3,@aa:8	2			2		
	BIST #xx:3,@aa:16	3			2		
	BIST #xx:3,@aa:32	4			2		
BIXOR	BIXOR #xx:3,Rd	1					
	BIXOR #xx:3,@ERd	2			1		
	BIXOR #xx:3,@aa:8	2			1		
	BIXOR #xx:3,@aa:16	3			1		
	BIXOR #xx:3,@aa:32	4			1		
BLD	BLD #xx:3,Rd	1					
	BLD #xx:3,@ERd	2			1		
	BLD #xx:3,@aa:8	2			1		
	BLD #xx:3,@aa:16	3			1		
	BLD #xx:3,@aa:32	4			1		

Instruction	Mnemonic	Instruction	Branch	Stack	Byte	Word	Internal
		Fetch	Address		Data	Data	
		I	J	K	L	M	N
BNOT	BNOT #xx:3,Rd	1					
	BNOT #xx:3,@ERd	2			2		
	BNOT #xx:3,@aa:8	2			2		
	BNOT #xx:3,@aa:16	3			2		
	BNOT #xx:3,@aa:32	4			2		
	BNOT Rn,Rd	1					
	BNOT Rn,@ERd	2				2	
	BNOT Rn,@aa:8	2				2	
	BNOT Rn,@aa:16	3				2	
BNOT Rn,@aa:32	4				2		
BOR	BOR #xx:3,Rd	1					
	BOR #xx:3,@ERd	2			1		
	BOR #xx:3,@aa:8	2			1		
	BOR #xx:3,@aa:16	3			1		
	BOR #xx:3,@aa:32	4			1		
BSET	BSET #xx:3,Rd	1					
	BSET #xx:3,@ERd	2			2		
	BSET #xx:3,@aa:8	2			2		
	BSET #xx:3,@aa:16	3			2		
	BSET #xx:3,@aa:32	4			2		
	BSET Rn,Rd	1					
	BSET Rn,@ERd	2				2	
	BSET Rn,@aa:8	2				2	
	BSET Rn,@aa:16	3				2	
BSET Rn,@aa:32	4				2		
BSR	BSR d:8	2		2			
	BSR d:16	2		2			1
BST	BST #xx:3,Rd	1					
	BST #xx:3,@ERd	2			2		
	BST #xx:3,@aa:8	2			2		
	BST #xx:3,@aa:16	3			2		
	BST #xx:3,@aa:32	4			2		

Instruction	Mnemonic	Instruction	Branch	Stack	Byte	Word	Internal
		Fetch	Address	Operation	Data	Data	Operation
		I	J	K	L	M	N
BTST	BTST #xx:3,Rd	1					
	BTST #xx:3,@ERd	2			1		
	BTST #xx:3,@aa:8	2			1		
	BTST #xx:3,@aa:16	3			1		
	BTST #xx:3,@aa:32	4			1		
	BTST Rn,Rd	1					
	BTST Rn,@ERd	2			1		
	BTST Rn,@aa:8	2			1		
	BTST Rn,@aa:16	3			1		
BTST Rn,@aa:32	4			1			
BXOR	BXOR #xx:3,Rd	1					
	BXOR #xx:3,@ERd	2			1		
	BXOR #xx:3,@aa:8	2			1		
	BXOR #xx:3,@aa:16	3			1		
	BXOR #xx:3,@aa:32	4			1		
CLRMAC	CLRMAC	1					1*3
CMP	CMP.B #xx:8,Rd	1					
	CMP.B Rs,Rd	1					
	CMP.W #xx:16,Rd	2					
	CMP.W Rs,Rd	1					
	CMP.L #xx:32,ERd	3					
	CMP.L ERs,ERd	1					
DAA	DAA Rd	1					
DAS	DAS Rd	1					
DEC	DEC.B Rd	1					
	DEC.W #1/2,Rd	1					
	DEC.L #1/2,ERd	1					
DIVXS	DIVXS.B Rs,Rd	2					11
	DIVXS.W Rs,ERd	2					19
DIVXU	DIVXU.B Rs,Rd	1					11
	DIVXU.W Rs,ERd	1					19

Instruction	Mnemonic	Instruction	Branch	Stack	Byte	Word	Internal	
		Fetch	Address		Data	Data		Operation
		I	J	K	L	M	N	
EEPMOV	EEPMOV.B	2			2n+2*2			
	EEPMOV.W	2			2n+2*2			
EXTS	EXTS.W Rd	1						
	EXTS.L ERd	1						
EXTU	EXTU.W Rd	1						
	EXTU.L ERd	1						
INC	INC.B Rd	1						
	INC.W #1/2,Rd	1						
	INC.L #1/2,ERd	1						
JMP	JMP @ERn	2						
	JMP @aa:24	2					1	
	JMP @@aa:8	2	2				1	
JSR	JSR @ERn	2		2				
	JSR @aa:24	2		2			1	
	JSR @@aa:8	2	2	2				
LDC	LDC #xx:8,CCR	1						
	LDC #xx:8,EXR	2						
	LDC Rs,CCR	1						
	LDC Rs,EXR	1						
	LDC @ERs,CCR	2					1	
	LDC @ERs,EXR	2					1	
	LDC @(d:16,ERs),CCR	3					1	
	LDC @(d:16,ERs),EXR	3					1	
	LDC @(d:32,ERs),CCR	5					1	
	LDC @(d:32,ERs),EXR	5					1	
	LDC @ERs+,CCR	2					1	1
	LDC @ERs+,EXR	2					1	1
	LDC @aa:16,CCR	3					1	
	LDC @aa:16,EXR	3					1	
	LDC @aa:32,CCR	4					1	
	LDC @aa:32,EXR	4					1	

Instruction	Mnemonic	Instruction	Branch	Stack	Byte	Word	Internal	
		Fetch	Address	Operation	Data	Data	Operation	
		I	J	K	L	M	N	
LDM	LDM.L @SP+, (ERn-ERn+1)	2		4			1	
	LDM.L @SP+, (ERn-ERn+2)	2		6			1	
	LDM.L @SP+, (ERn-ERn+3)	2		8			1	
LDMAC	LDMAC ERs,MACH	1					1*3	
	LDMAC ERs,MACL	1					1*3	
MAC	MAC @ERn+,@ERm+	2				2		
MOV	MOV.B #xx:8,Rd	1						
	MOV.B Rs,Rd	1						
	MOV.B @ERs,Rd	1				1		
	MOV.B @(d:16,ERs),Rd	2				1		
	MOV.B @(d:32,ERs),Rd	4				1		
	MOV.B @ERs+,Rd	1				1	1	
	MOV.B @aa:8,Rd	1				1		
	MOV.B @aa:16,Rd	2				1		
	MOV.B @aa:32,Rd	3				1		
	MOV.B Rs,@ERd	1				1		
	MOV.B Rs,@(d:16,ERd)	2				1		
	MOV.B Rs,@(d:32,ERd)	4				1		
	MOV.B Rs,@-ERd	1				1	1	
	MOV.B Rs,@aa:8	1				1		
	MOV.B Rs,@aa:16	2				1		
	MOV.B Rs,@aa:32	3				1		
	MOV.W #xx:16,Rd	2						
	MOV.W Rs,Rd	1						
	MOV.W @ERs,Rd	1					1	
	MOV.W @(d:16,ERs),Rd	2					1	
	MOV.W @(d:32,ERs),Rd	4					1	
	MOV.W @ERs+,Rd	1					1	1
	MOV.W @aa:16,Rd	2					1	
	MOV.W @aa:32,Rd	3					1	
	MOV.W Rs,@ERd	1					1	

Instruction	Mnemonic	Instruction	Branch	Stack	Byte	Word	Internal	
		Fetch	Address		Data	Data		Operation
		I	J	K	L	M	N	
MOV	MOV.W Rs,@(d:16,ERd)	2				1		
	MOV.W Rs,@(d:32,ERd)	4				1		
	MOV.W Rs,@-ERd	1				1	1	
	MOV.W Rs,@aa:16	2				1		
	MOV.W Rs,@aa:32	3				1		
	MOV.L #xx:32,ERd	3						
	MOV.L ERs,ERd	1						
	MOV.L @ERs,ERd	2					2	
	MOV.L @(d:16,ERs),ERd	3					2	
	MOV.L @(d:32,ERs),ERd	5					2	
	MOV.L @ERs+,ERd	2					2	1
	MOV.L @aa:16,ERd	3					2	
	MOV.L @aa:32,ERd	4					2	
	MOV.L ERs,@ERd	2					2	
	MOV.L ERs,@(d:16,ERd)	3					2	
	MOV.L ERs,@(d:32,ERd)	5					2	
	MOV.L ERs,@-ERd	2					2	1
	MOV.L ERs,@aa:16	3					2	
MOV.L ERs,@aa:32	4					2		
MOVFP	MOVFP @:aa:16,Rd	Can not be used in this LSI						
MOVTPE	MOVTPE Rs,@:aa:16							
MULXS	MULXS.B Rs,Rd	2					2	
	MULXS.W Rs,ERd	2					3	
MULXU	MULXU.B Rs,Rd	1					2	
	MULXU.W Rs,ERd	1					3	
NEG	NEG.B Rd	1						
	NEG.W Rd	1						
	NEG.L ERd	1						
NOP	NOP	1						
NOT	NOT.B Rd	1						
	NOT.W Rd	1						
	NOT.L ERd	1						

Instruction	Mnemonic	Instruction	Branch	Stack	Byte	Word	Internal
		Fetch	Address	Operation	Data	Data	
		I	J	K	L	M	N
OR	OR.B #xx:8,Rd	1					
	OR.B Rs,Rd	1					
	OR.W #xx:16,Rd	2					
	OR.W Rs,Rd	1					
	OR.L #xx:32,ERd	3					
	OR.L ERs,ERd	2					
ORC	ORC #xx:8,CCR	1					
	ORC #xx:8,EXR	2					
POP	POP.W Rn	1				1	1
	POP.L ERn	2				2	1
PUSH	PUSH.W Rn	1				1	1
	PUSH.L ERn	2				2	1
ROTL	ROTL.B Rd	1					
	ROTL.B #2,Rd	1					
	ROTL.W Rd	1					
	ROTL.W #2,Rd	1					
	ROTL.L ERd	1					
	ROTL.L #2,ERd	1					
ROTR	ROTR.B Rd	1					
	ROTR.B #2,Rd	1					
	ROTR.W Rd	1					
	ROTR.W #2,Rd	1					
	ROTR.L ERd	1					
	ROTR.L #2,ERd	1					
ROTXL	ROTXL.B Rd	1					
	ROTXL.B #2,Rd	1					
	ROTXL.W Rd	1					
	ROTXL.W #2,Rd	1					
	ROTXL.L ERd	1					
	ROTXL.L #2,ERd	1					

Instruction	Mnemonic	Instruction	Branch	Stack	Byte	Word	Internal
		Fetch	Address		Data	Data	
		I	J	K	L	M	N
ROTXR	ROTXR.B Rd	1					
	ROTXR.B #2,Rd	1					
	ROTXR.W Rd	1					
	ROTXR.W #2,Rd	1					
	ROTXR.L ERd	1					
	ROTXR.L #2,ERd	1					
RTE	RTE	2		2/3*1			1
RTS	RTS	2		2			1
SHAL	SHAL.B Rd	1					
	SHAL.B #2,Rd	1					
	SHAL.W Rd	1					
	SHAL.W #2,Rd	1					
	SHAL.L ERd	1					
	SHAL.L #2,ERd	1					
SHAR	SHAR.B Rd	1					
	SHAR.B #2,Rd	1					
	SHAR.W Rd	1					
	SHAR.W #2,Rd	1					
	SHAR.L ERd	1					
	SHAR.L #2,ERd	1					
SHLL	SHLL.B Rd	1					
	SHLL.B #2,Rd	1					
	SHLL.W Rd	1					
	SHLL.W #2,Rd	1					
	SHLL.L ERd	1					
	SHLL.L #2,ERd	1					
SHLR	SHLR.B Rd	1					
	SHLR.B #2,Rd	1					
	SHLR.W Rd	1					
	SHLR.W #2,Rd	1					
	SHLR.L ERd	1					
	SHLR.L #2,ERd	1					
SLEEP	SLEEP	1					1

Instruction	Mnemonic	Instruction	Branch	Stack	Byte	Word	Internal
		Fetch	Address		Data	Data	
		I	J	K	L	M	N
STC	STC.B CCR,Rd	1					
	STC.B EXR,Rd	1					
	STC.W CCR,@ERd	2				1	
	STC.W EXR,@ERd	2				1	
	STC.W CCR,@(d:16,ERd)	3				1	
	STC.W EXR,@(d:16,ERd)	3				1	
	STC.W CCR,@(d:32,ERd)	5				1	
	STC.W EXR,@(d:32,ERd)	5				1	
	STC.W CCR,@-ERd	2				1	1
	STC.W EXR,@-ERd	2				1	1
	STC.W CCR,@aa:16	3				1	
	STC.W EXR,@aa:16	3				1	
	STC.W CCR,@aa:32	4				1	
	STC.W EXR,@aa:32	4				1	
STM	STM.L (ERn-ERn+1), @-SP	2		4			1
	STM.L (ERn-ERn+2), @-SP	2		6			1
	STM.L (ERn-ERn+3), @-SP	2		8			1
STMAC	STMAC MACH,ERd	1					0*3
	STMAC MACL,ERd	1					0*3
SUB	SUB.B Rs,Rd	1					
	SUB.W #xx:16,Rd	2					
	SUB.W Rs,Rd	1					
	SUB.L #xx:32,ERd	3					
	SUB.L ERs,ERd	1					
SUBS	SUBS #1/2/4,ERd	1					
SUBX	SUBX #xx:8,Rd	1					
	SUBX Rs,Rd	1					
TAS*4	TAS @ERd	2			2		
TRAPA	TRAPA #x:2	2	2	2/3*1			2

Instruction	Mnemonic	Instruction	Branch	Stack	Byte	Word	Internal
		Fetch	Address		Data	Data	
		I	J	K	L	M	N
XOR	XOR.B #xx:8,Rd	1					
	XOR.B Rs,Rd	1					
	XOR.W #xx:16,Rd	2					
	XOR.W Rs,Rd	1					
	XOR.L #xx:32,ERd	3					
	XOR.L ERs,ERd	2					
XORC	XORC #xx:8,CCR	1					
	XORC #xx:8,EXR	2					

- Notes:
1. 2 when EXR is invalid, 3 when EXR is valid.
 2. When n bytes of data are transferred.
 3. An internal operation may require between 0 and 3 additional states, depending on the preceding instruction.
 4. Only register ER0, ER1, ER4, or ER5 should be used when using the TAS instruction.

A.5 Bus States during Instruction Execution

Table A-6 indicates the types of cycles that occur during instruction execution by the CPU. See table A-4 for the number of states per cycle.

How to Read the Table:

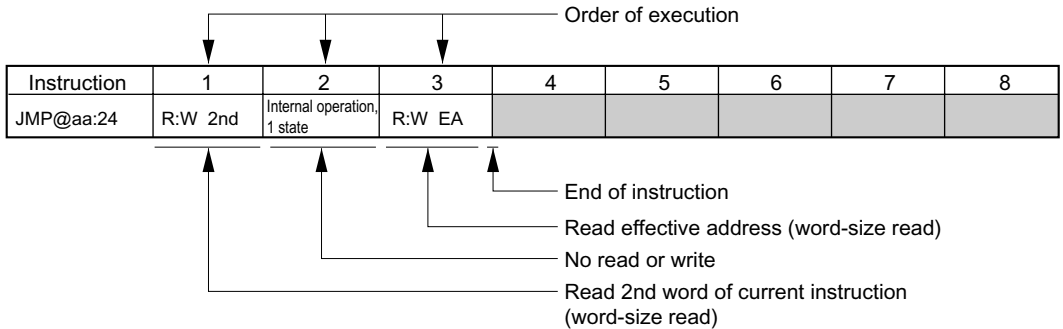

Legend

R:B	Byte-size read
R:W	Word-size read
W:B	Byte-size write
W:W	Word-size write
:M	Transfer of the bus is not performed immediately after this cycle
2nd	Address of 2nd word (3rd and 4th bytes)
3rd	Address of 3rd word (5th and 6th bytes)
4th	Address of 4th word (7th and 8th bytes)
5th	Address of 5th word (9th and 10th bytes)
NEXT	Address of next instruction
EA	Effective address
VEC	Vector address

Figure A-1 shows timing waveforms for the address bus and the \overline{RD} , \overline{HWR} , and \overline{LWR} signals during execution of the above instruction with an 8-bit bus, using three-state access with no wait states.

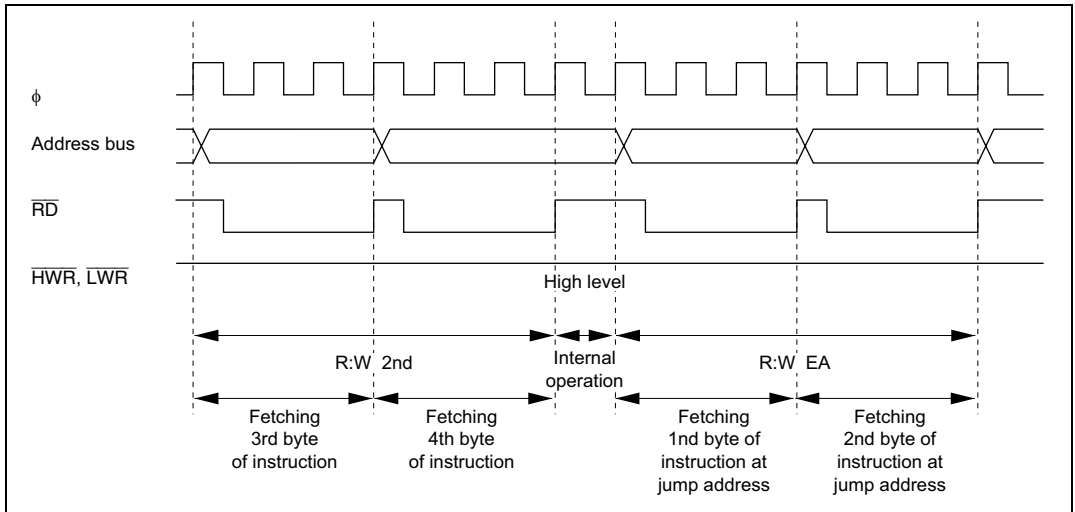

**Figure A-1 Address Bus, \overline{RD} , \overline{HWR} , and \overline{LWR} Timing
(8-Bit Bus, Three-State Access, No Wait States)**

Table A-6 Instruction Execution Cycles

Instruction	1	2	3	4	5	6	7	8	9
ADD.B #xx:8,Rd	R:W NEXT								
ADD.B Rs,Rd	R:W NEXT								
ADD.W #xx:16,Rd	R:W 2nd	R:W NEXT							
ADD.W Rs,Rd	R:W NEXT								
ADD.L #xx:32,ERd	R:W 2nd	R:W 3rd	R:W NEXT						
ADD.L ERs,ERd	R:W NEXT								
ADDS #1/2/4,ERd	R:W NEXT								
ADDD #xx:8,Rd	R:W NEXT								
ADDD Rs,Rd	R:W NEXT								
AND.B #xx:8,Rd	R:W NEXT								
AND.B Rs,Rd	R:W NEXT								
AND.W #xx:16,Rd	R:W 2nd	R:W NEXT							
AND.W Rs,Rd	R:W NEXT								
AND.L #xx:32,ERd	R:W 2nd	R:W 3rd	R:W NEXT						
AND.L ERs,ERd	R:W 2nd	R:W NEXT							
ANDC #xx:8,CCR	R:W NEXT								
ANDC #xx:8,EXR	R:W 2nd	R:W NEXT							
BAND #xx:3,Rd	R:W NEXT								
BAND #xx:3,@ERd	R:W 2nd	R:B EA	R:W:M NEXT						
BAND #xx:3,@aa:8	R:W 2nd	R:B EA	R:W:M NEXT						
BAND #xx:3,@aa:16	R:W 2nd	R:W 3rd	R:B EA	R:W:M NEXT					
BAND #xx:3,@aa:32	R:W 2nd	R:W 3rd	R:W 4th	R:B EA	R:W:M NEXT				
BRA d:8 (BT d:8)	R:W NEXT	R:W EA							
BRN d:8 (BF d:8)	R:W NEXT	R:W EA							
BHI d:8	R:W NEXT	R:W EA							
BLS d:8	R:W NEXT	R:W EA							
BCC d:8 (BHS d:8)	R:W NEXT	R:W EA							
BCS d:8 (BLO d:8)	R:W NEXT	R:W EA							
BNE d:8	R:W NEXT	R:W EA							
BEQ d:8	R:W NEXT	R:W EA							
BVC d:8	R:W NEXT	R:W EA							
BVS d:8	R:W NEXT	R:W EA							
BPL d:8	R:W NEXT	R:W EA							
BMI d:8	R:W NEXT	R:W EA							
BGE d:8	R:W NEXT	R:W EA							
BLT d:8	R:W NEXT	R:W EA							
BGT d:8	R:W NEXT	R:W EA							

Instruction	1	2	3	4	5	6	7	8	9
BLE d:8	R:W NEXT	R:W EA							
BRA d:16 (BT d:16)	R:W 2nd 1 state	Internal operation, 1 state	R:W EA						
BRN d:16 (BF d:16)	R:W 2nd 1 state	Internal operation, 1 state	R:W EA						
BHI d:16	R:W 2nd 1 state	Internal operation, 1 state	R:W EA						
BLS d:16	R:W 2nd 1 state	Internal operation, 1 state	R:W EA						
BCC d:16 (BHS d:16)	R:W 2nd 1 state	Internal operation, 1 state	R:W EA						
BCS d:16 (BLO d:16)	R:W 2nd 1 state	Internal operation, 1 state	R:W EA						
BNE d:16	R:W 2nd 1 state	Internal operation, 1 state	R:W EA						
BEQ d:16	R:W 2nd 1 state	Internal operation, 1 state	R:W EA						
BVC d:16	R:W 2nd 1 state	Internal operation, 1 state	R:W EA						
BVS d:16	R:W 2nd 1 state	Internal operation, 1 state	R:W EA						
BPL d:16	R:W 2nd 1 state	Internal operation, 1 state	R:W EA						
BMI d:16	R:W 2nd 1 state	Internal operation, 1 state	R:W EA						
BGE d:16	R:W 2nd 1 state	Internal operation, 1 state	R:W EA						
BLT d:16	R:W 2nd 1 state	Internal operation, 1 state	R:W EA						
BGT d:16	R:W 2nd 1 state	Internal operation, 1 state	R:W EA						
BLE d:16	R:W 2nd 1 state	Internal operation, 1 state	R:W EA						
BCLR #xx:3,Rd	R:W NEXT								
BCLR #xx:3,@ERd	R:W 2nd	R:B:M EA	R:W:M NEXT	W:B EA					
BCLR #xx:3,@aa:8	R:W 2nd	R:B:M EA	R:W:M NEXT	W:B EA					
BCLR #xx:3,@aa:16	R:W 2nd	R:W 3rd	R:B:M EA	R:W:M NEXT	W:B EA				

Instruction	1	2	3	4	5	6	7	8	9
BCLR #xx:3,@aa:32	R:W 2nd	R:W 3rd	R:W 4th	R:B:ME A	R:W:M NEXT	W:B EA			
BCLR Rn,Rd	R:W NEXT								
BCLR Rn,@ERd	R:W 2nd	R:B:M EA	R:W:M NEXT	W:B EA					
BCLR Rn,@aa:8	R:W 2nd	R:B:M EA	R:W:M NEXT	W:B EA					
BCLR Rn,@aa:16	R:W 2nd	R:W 3rd	R:B:M EA	R:W:M NEXT	W:B EA				
BCLR Rn,@aa:32	R:W 2nd	R:W 3rd	R:W 4th	R:B:M EA	R:W:M NEXT	W:B EA			
BIAND #xx:3,Rd	R:W NEXT								
BIAND #xx:3,@ERd	R:W 2nd	R:B EA	R:W:M NEXT						
BIAND #xx:3,@aa:8	R:W 2nd	R:B EA	R:W:M NEXT						
BIAND #xx:3,@aa:16	R:W 2nd	R:W 3rd	R:B EA	R:W:M NEXT					
BIAND #xx:3,@aa:32	R:W 2nd	R:W 3rd	R:W 4th	R:B EA	R:W:M NEXT				
BILD #xx:3,Rd	R:W NEXT								
BILD #xx:3,@ERd	R:W 2nd	R:B EA	R:W:M NEXT						
BILD #xx:3,@aa:8	R:W 2nd	R:B EA	R:W:M NEXT						
BILD #xx:3,@aa:16	R:W 2nd	R:W 3rd	R:B EA	R:W:M NEXT					
BILD #xx:3,@aa:32	R:W 2nd	R:W 3rd	R:W 4th	R:B EA	R:W:M NEXT				
BIOR #xx:3,Rd	R:W NEXT								
BIOR #xx:3,@ERd	R:W 2nd	R:B EA	R:W:M NEXT						
BIOR #xx:3,@aa:8	R:W 2nd	R:B EA	R:W:M NEXT						
BIOR #xx:3,@aa:16	R:W 2nd	R:W 3rd	R:B EA	R:W:M NEXT					
BIOR #xx:3,@aa:32	R:W 2nd	R:W 3rd	R:W 4th	R:B EA	R:W:M NEXT				
BIST #xx:3,Rd	R:W NEXT								
BIST #xx:3,@ERd	R:W 2nd	R:B:M EA	R:W:M NEXT	W:B EA					
BIST #xx:3,@aa:8	R:W 2nd	R:B:M EA	R:W:M NEXT	W:B EA					
BIST #xx:3,@aa:16	R:W 2nd	R:W 3rd	R:B:M EA	R:W:M NEXT	W:B EA				
BIST #xx:3,@aa:32	R:W 2nd	R:W 3rd	R:W 4th	R:B:M EA	R:W:M NEXT	W:B EA			
BIXOR #xx:3,Rd	R:W NEXT								
BIXOR #xx:3,@ERd	R:W 2nd	R:B EA	R:W:M NEXT						
BIXOR #xx:3,@aa:8	R:W 2nd	R:B:M EA	R:W:M NEXT	W:B EA					
BIXOR #xx:3,@aa:16	R:W 2nd	R:W 3rd	R:B:M EA	R:W:M NEXT	W:B EA				
BIXOR #xx:3,@aa:32	R:W 2nd	R:W 3rd	R:W 4th	R:B:M EA	R:W:M NEXT	W:B EA			
BLD #xx:3,Rd	R:W NEXT								
BLD #xx:3,@ERd	R:W 2nd	R:B EA	R:W:M NEXT						
BLD #xx:3,@aa:8	R:W 2nd	R:B EA	R:W:M NEXT						
BLD #xx:3,@aa:16	R:W 2nd	R:W 3rd	R:B EA	R:W:M NEXT					
BLD #xx:3,@aa:32	R:W 2nd	R:W 3rd	R:W 4th	R:B EA	R:W:M NEXT				
BNOT #xx:3,Rd	R:W NEXT								

Instruction	1	2	3	4	5	6	7	8	9
BNOT #xx:3,@ERd	R:W 2nd	R:B:M EA	R:W:M NEXT	W:B EA					
BNOT #xx:3,@aa:8	R:W 2nd	R:B:M EA	R:W:M NEXT	W:B EA					
BNOT #xx:3,@aa:16	R:W 2nd	R:W 3rd	R:B:M EA	R:W:M NEXT	W:B EA				
BNOT #xx:3,@aa:32	R:W 2nd	R:W 3rd	R:W 4th	R:B:M EA	R:W:M NEXT	W:B EA			
BNOT Rn,Rd	R:W NEXT								
BNOT Rn,@ERd	R:W 2nd	R:B:M EA	R:W:M NEXT	W:B EA					
BNOT Rn,@aa:8	R:W 2nd	R:B:M EA	R:W:M NEXT	W:B EA					
BNOT Rn,@aa:16	R:W 2nd	R:W 3rd	R:B:M EA	R:W:M NEXT	W:B EA				
BNOT Rn,@aa:32	R:W 2nd	R:W 3rd	R:W 4th	R:B:M EA	R:W:M NEXT	W:B EA			
BOR #xx:3,Rd	R:W NEXT								
BOR #xx:3,@ERd	R:W 2nd	R:B EA	R:W:M NEXT						
BOR #xx:3,@aa:8	R:W 2nd	R:B EA	R:W:M NEXT						
BOR #xx:3,@aa:16	R:W 2nd	R:W 3rd	R:B EA	R:W:M NEXT					
BOR #xx:3,@aa:32	R:W 2nd	R:W 3rd	R:W 4th	R:B EA	R:W:M NEXT				
BSET #xx:3,Rd	R:W NEXT								
BSET #xx:3,@ERd	R:W 2nd	R:B:M EA	R:W:M NEXT	W:B EA					
BSET #xx:3,@aa:8	R:W 2nd	R:B:M EA	R:W:M NEXT	W:B EA					
BSET #xx:3,@aa:16	R:W 2nd	R:W 3rd	R:B:M EA	R:W:M NEXT	W:B EA				
BSET #xx:3,@aa:32	R:W 2nd	R:W 3rd	R:W 4th	R:B:M EA	R:W:M NEXT	W:B EA			
BSET Rn,Rd	R:W NEXT								
BSET Rn,@ERd	R:W 2nd	R:B:M EA	R:W:M NEXT	W:B EA					
BSET Rn,@aa:8	R:W 2nd	R:B:M EA	R:W:M NEXT	W:B EA					
BSET Rn,@aa:16	R:W 2nd	R:W 3rd	R:B:M EA	R:W:M NEXT	W:B EA				
BSET Rn,@aa:32	R:W 2nd	R:W 3rd	R:W 4th	R:B:M EA	R:W:M NEXT	W:B EA			
BSR d:8	R:W NEXT								
BSR d:16	R:W 2nd	Internal operation, 1 state	W:W:M stack (H) R:W EA	W:W stack (L) W:W:M stack (H)	W:W stack (L)				
BST #xx:3,Rd	R:W NEXT								
BST #xx:3,@ERd	R:W 2nd	R:B:M EA	R:W:M NEXT	W:B EA					
BST #xx:3,@aa:8	R:W 2nd	R:B:M EA	R:W:M NEXT	W:B EA					
BST #xx:3,@aa:16	R:W 2nd	R:W 3rd	R:B:M EA	R:W:M NEXT	W:B EA				
BST #xx:3,@aa:32	R:W 2nd	R:W 3rd	R:W 4th	R:B:M EA	R:W:M NEXT	W:B EA			
BTST #xx:3,Rd	R:W NEXT								
BTST #xx:3,@ERd	R:W 2nd	R:B EA	R:W:M NEXT						

Instruction	1	2	3	4	5	6	7	8	9
BTST #xx:3,@aa:8	R:W 2nd	R:B EA	R:W:M NEXT						
BTST #xx:3,@aa:16	R:W 2nd	R:W 3rd	R:B EA	R:W:M NEXT					
BTST #xx:3,@aa:32	R:W 2nd	R:W 3rd	R:W 4th	R:B EA	R:W:M NEXT				
BTST Rn,Rd	R:W NEXT								
BTST Rn,@ERd	R:W 2nd	R:B EA	R:W:M NEXT						
BTST Rn,@aa:8	R:W 2nd	R:B EA	R:W:M NEXT						
BTST Rn,@aa:16	R:W 2nd	R:W 3rd	R:B EA	R:W:M NEXT					
BTST Rn,@aa:32	R:W 2nd	R:W 3rd	R:W 4th	R:B EA	R:W:M NEXT				
BXOR #xx:3,Rd	R:W NEXT								
BXOR #xx:3,@ERd	R:W 2nd	R:B EA	R:W:M NEXT						
BXOR #xx:3,@aa:8	R:W 2nd	R:B EA	R:W:M NEXT						
BXOR #xx:3,@aa:16	R:W 2nd	R:W 3rd	R:B EA	R:W:M NEXT					
BXOR #xx:3,@aa:32	R:W 2nd	R:W 3rd	R:W 4th	R:B EA	R:W:M NEXT				
CLRMAC	R:W NEXT	Internal operation, 1 state							
CMP.B #xx:8,Rd	R:W NEXT								
CMP.B Rs,Rd	R:W NEXT								
CMP.W #xx:16,Rd	R:W 2nd	R:W NEXT							
CMP.W Rs,Rd	R:W NEXT								
CMP.L #xx:32,ERd	R:W 2nd	R:W 3rd	R:W NEXT						
CMP.L ERs,ERd	R:W NEXT								
DAA Rd	R:W NEXT								
DAS Rd	R:W NEXT								
DEC.B Rd	R:W NEXT								
DEC.W #1/2,Rd	R:W NEXT								
DECL #1/2,ERd	R:W NEXT								
DIVXS.W Rs,ERd	R:W 2nd	R:W NEXT	Internal operation, 11 states						
DIVXS.B Rs,Rd	R:W 2nd	R:W NEXT	Internal operation, 19 states						
DIVXU.W Rs,ERd	R:W NEXT	Internal operation, 19 states							
DIVXU.B Rs,Rd	R:W NEXT	Internal operation, 11 states							
EEPMOV.B	R:W 2nd	R:B EAs*1	R:B EAd*1	R:B EAs*2	W:B EAd*2	R:W NEXT			
EEPMOV.W	R:W 2nd	R:B EAs*1	R:B EAd*1	R:B EAs*2	W:B EAd*2	R:W NEXT			
EXTS.W Rd	R:W NEXT				← Repeated n times*2 →				
EXTS.L ERd	R:W NEXT								
EXTU.W Rd	R:W NEXT								
EXTU.L ERd	R:W NEXT								
INC.B Rd	R:W NEXT								

Instruction	1	2	3	4	5	6	7	8	9
INC.W #1/2,Rd	R:W NEXT								
INC.L #1/2,ERd	R:W NEXT								
JMP @ERn	R:W NEXT	R:W EA							
JMP @aa:24	R:W 2nd 1 state	Internal operation, 1 state	R:W EA						
JMP @@aaa:8	R:W NEXT	R:W/M aa:8	R:W aa:8	Internal operation, 1 state	R:W EA				
JSR @ERn	R:W NEXT	R:W EA	W:W/M stack (H) W:W stack (L)	W:W stack (L)					
JSR @aa:24	R:W 2nd 1 state	Internal operation, 1 state	R:W EA	W:W/M stack (H)	W:W stack (L)				
JSR @@aaa:8	R:W NEXT	R:W/M aa:8	R:W aa:8	W:W/M stack (H)	W:W stack (L)	R:W EA			
LDC #xx:8,CCR	R:W NEXT								
LDC #xx:8,EXR	R:W 2nd	R:W NEXT							
LDC Rs,CCR	R:W NEXT								
LDC Rs,EXR	R:W NEXT								
LDC @ERs,CCR	R:W 2nd	R:W NEXT	R:W EA						
LDC @ERs,EXR	R:W 2nd	R:W NEXT	R:W EA						
LDC @(d:16,ERs),CCR	R:W 2nd	R:W 3rd	R:W NEXT	R:W EA					
LDC @(d:16,ERs),EXR	R:W 2nd	R:W 3rd	R:W NEXT	R:W EA					
LDC @(d:32,ERs),CCR	R:W 2nd	R:W 3rd	R:W 4th	R:W 5th	R:W NEXT	R:W EA			
LDC @(d:32,ERs),EXR	R:W 2nd	R:W 3rd	R:W 4th	R:W 5th	R:W NEXT	R:W EA			
LDC @ERs+,CCR	R:W 2nd	R:W NEXT	Internal operation, 1 state	R:W EA					
LDC @ERs+,EXR	R:W 2nd	R:W NEXT	Internal operation, 1 state	R:W EA					
LDC @aa:16,CCR	R:W 2nd	R:W 3rd	R:W NEXT	R:W EA					
LDC @aa:16,EXR	R:W 2nd	R:W 3rd	R:W NEXT	R:W EA					
LDC @aa:32,CCR	R:W 2nd	R:W 3rd	R:W 4th	R:W NEXT	R:W EA				
LDC @aa:32,EXR	R:W 2nd	R:W 3rd	R:W 4th	R:W NEXT	R:W EA				
LDM.L @SP+, (ERn-ERn+1)*9	R:W 2nd	R:W/M NEXT	Internal operation, 1 state	R:W/M stack (H)*3	R:W stack (L)*3				
LDM.L @SP+,(ERn-ERn+2)*9	R:W 2nd	R:W NEXT	Internal operation, 1 state	R:W/M stack (H)*3	R:W stack (L)*3				
LDM.L @SP+,(ERn-ERn+3)*9	R:W 2nd	R:W NEXT	Internal operation, 1 state	R:W/M stack (H)*3	R:W stack (L)*3				
LDMAC ERs,MACH	R:W NEXT	Internal operation, 1 state	Internal operation, 1 state	← Repeated n times *3 →					

Instruction	1	2	3	4	5	6	7	8	9
LDMAC ERs, MACL	R:W NEXT	Internal operation, 1 state							
MAC @ERn+,@ERm+	R:W 2nd	R:W NEXT	R:W EAh	R:W EA					
MOV.B #xx:8,Rd	R:W NEXT	R:W NEXT							
MOV.B Rs,Rd	R:W NEXT								
MOV.B @ERs,Rd	R:W NEXT	R:B EA							
MOV.B @(d:16,ERs),Rd	R:W 2nd	R:W NEXT	R:B EA						
MOV.B @(d:32,ERs),Rd	R:W 2nd	R:W 3rd	R:W 4th	R:W NEXT	R:B EA				
MOV.B @ERs+,Rd	R:W NEXT	Internal operation, 1 state	R:B EA						
MOV.B @aa:8,Rd	R:W NEXT	R:B EA							
MOV.B @aa:16,Rd	R:W 2nd	R:W NEXT	R:B EA						
MOV.B @aa:32,Rd	R:W 2nd	R:W 3rd	R:W NEXT	R:B EA					
MOV.B Rs,@ERd	R:W NEXT	W:B EA							
MOV.B Rs,@(d:16,ERd)	R:W 2nd	R:W NEXT	W:B EA						
MOV.B Rs,@(d:32,ERd)	R:W 2nd	R:W 3rd	R:W 4th	R:W NEXT	W:B EA				
MOV.B Rs,@-ERd	R:W NEXT	Internal operation, 1 state	W:B EA						
MOV.B Rs,@aa:8	R:W NEXT	W:B EA							
MOV.B Rs,@aa:16	R:W 2nd	R:W NEXT	W:B EA						
MOV.B Rs,@aa:32	R:W 2nd	R:W 3rd	R:W NEXT	W:B EA					
MOV.W #xx:16,Rd	R:W 2nd	R:W NEXT							
MOV.W Rs,Rd	R:W NEXT								
MOV.W @ERs,Rd	R:W NEXT	R:W EA							
MOV.W @(d:16,ERs),Rd	R:W 2nd	R:W NEXT	R:W EA						
MOV.W @(d:32,ERs),Rd	R:W 2nd	R:W 3rd	R:W 4th	R:W NEXT	R:W EA				
MOV.W @ERs+,Rd	R:W NEXT	Internal operation, 1 state	R:W EA						
MOV.W @aa:16,Rd	R:W 2nd	R:W NEXT	R:W EA						
MOV.W @aa:32,Rd	R:W 2nd	R:W 3rd	R:W NEXT	R:B EA					
MOV.W Rs,@ERd	R:W NEXT	W:W EA							
MOV.W Rs,@(d:16,ERd)	R:W 2nd	R:W NEXT	W:W EA						
MOV.W Rs,@(d:32,ERd)	R:W 2nd	R:W 3rd	R:W 4th	R:W NEXT	W:W EA				
MOV.W Rs,@-ERd	R:W NEXT	Internal operation, 1 state	W:W EA						
MOV.W Rs,@aa:16	R:W 2nd	R:W NEXT	W:W EA						
MOV.W Rs,@aa:32	R:W 2nd	R:W 3rd	R:W NEXT	W:W EA					

Instruction	1	2	3	4	5	6	7	8	9
MOV.L #xx:32,ERd	R:W 2nd	R:W 3rd	R:W NEXT						
MOV.L ERs,ERd	R:W NEXT								
MOV.L @ERs,ERd	R:W 2nd	R:W:M NEXT	R:W:M EA	R:W EA+2					
MOV.L @(d:16),ERs,ERd	R:W 2nd	R:W:M 3rd	R:W NEXT	R:W:M EA	R:W EA+2				
MOV.L @(d:32),ERs,ERd	R:W 2nd	R:W:M 3rd	R:W:M 4th	R:W 5th	R:W NEXT	R:W:M EA	R:W EA+2		
MOV.L @ERs+,ERd	R:W 2nd	R:W:M NEXT	Internal operation, 1 state	R:W:M EA	R:W EA+2				
MOV.L @aa:16,ERd	R:W 2nd	R:W:M 3rd	R:W NEXT	R:W:M EA	R:W EA+2				
MOV.L @aa:32,ERd	R:W 2nd	R:W:M 3rd	R:W 4th	R:W NEXT	R:W:M EA	R:W EA+2			
MOV.L ERs,@ERd	R:W 2nd	R:W:M NEXT	W:W:M EA	W:W EA+2					
MOV.L ERs,@(d:16),ERd	R:W 2nd	R:W:M 3rd	R:W NEXT	W:W:M EA	W:W EA+2				
MOV.L ERs,@(d:32),ERd	R:W 2nd	R:W:M 3rd	R:W:M 4th	R:W 5th	R:W NEXT	W:W:M EA	W:W EA+2		
MOV.L ERs@-,ERd	R:W 2nd	R:W:M NEXT	Internal operation, 1 state	W:W:M EA	W:W EA+2				
MOV.L ERs@aa:16	R:W 2nd	R:W:M 3rd	R:W NEXT	W:W:M EA	W:W EA+2				
MOV.L ERs@aa:32	R:W 2nd	R:W:M 3rd	R:W 4th	R:W NEXT	W:W:M EA	W:W EA+2			
MOVFPPE @aa:16,Rd	Cannot be used in this LSI								
MOVFPPE Rs@aa:16									
MULXS.B Rs,Rd	R:W 2nd	R:W NEXT	Internal operation, 2 states						
MULXS.W Rs,ERd	R:W 2nd	R:W NEXT	Internal operation, 3 states						
MULXU.B Rs,Rd	R:W NEXT	Internal operation, 2 states							
MULXU.W Rs,ERd	R:W NEXT	Internal operation, 3 states							
NEG.B Rd	R:W NEXT								
NEG.W Rd	R:W NEXT								
NEG.L ERd	R:W NEXT								
NOP	R:W NEXT								
NOT.B Rd	R:W NEXT								
NOT.W Rd	R:W NEXT								
NOT.L ERd	R:W NEXT								
OR.B #xx:8,Rd	R:W NEXT								
OR.B Rs,Rd	R:W NEXT								
OR.W #xx:16,Rd	R:W 2nd	R:W NEXT							
OR.W Rs,Rd	R:W NEXT								
OR.L #xx:32,ERd	R:W 2nd	R:W 3rd	R:W NEXT						
OR.L ERs,ERd	R:W 2nd	R:W NEXT							
ORC #xx:8,CCR	R:W NEXT								
ORC #xx:8,EXR	R:W 2nd	R:W NEXT							

Instruction	1	2	3	4	5	6	7	8	9
POP.W Rn	R:W NEXT	Internal operation, 1 state	R:W EA						
POP.L ERn	R:W 2nd	R:W:M NEXT	Internal operation, 1 state	R:W:M EA	R:W EA+2				
PUSH.W Rn	R:W NEXT	Internal operation, 1 state	W:W EA						
PUSH.L ERn	R:W 2nd	R:W:M NEXT	Internal operation, 1 state	W:W:M EA	W:W EA+2				
ROTL.B Rd	R:W NEXT								
ROTL.B #2,Rd	R:W NEXT								
ROTL.W Rd	R:W NEXT								
ROTL.W #2,Rd	R:W NEXT								
ROTL.L ERd	R:W NEXT								
ROTL.L #2,ERd	R:W NEXT								
ROTR.B Rd	R:W NEXT								
ROTR.B #2,Rd	R:W NEXT								
ROTR.W Rd	R:W NEXT								
ROTR.W #2,Rd	R:W NEXT								
ROTR.L ERd	R:W NEXT								
ROTR.L #2,ERd	R:W NEXT								
ROTL.B Rd	R:W NEXT								
ROTL.B #2,Rd	R:W NEXT								
ROTL.W Rd	R:W NEXT								
ROTL.W #2,Rd	R:W NEXT								
ROTL.L ERd	R:W NEXT								
ROTL.L #2,ERd	R:W NEXT								
ROXR.B Rd	R:W NEXT								
ROXR.B #2,Rd	R:W NEXT								
ROXR.W Rd	R:W NEXT								
ROXR.W #2,Rd	R:W NEXT								
ROXR.L ERd	R:W NEXT								
ROXR.L #2,ERd	R:W NEXT								
RTE	R:W NEXT	R:W stack (EXR)	R:W stack (H)	R:W stack (L)	Internal operation, 1 state	R:W ^{#4}			
RTS	R:W NEXT	R:W:M stack (H)	R:W stack (L)	Internal operation, 1 state	R:W ^{#4}				
SHAL.B Rd	R:W NEXT								

Instruction	1	2	3	4	5	6	7	8	9
SHAL.B #2,Rd	R:W NEXT								
SHAL.W Rd	R:W NEXT								
SHAL.W #2,Rd	R:W NEXT								
SHAL.L ERd	R:W NEXT								
SHAL.L #2,ERd	R:W NEXT								
SHAR.B Rd	R:W NEXT								
SHAR.B #2,Rd	R:W NEXT								
SHAR.W Rd	R:W NEXT								
SHAR.W #2,Rd	R:W NEXT								
SHAR.L ERd	R:W NEXT								
SHAR.L #2,ERd	R:W NEXT								
SHLL.B Rd	R:W NEXT								
SHLL.B #2,Rd	R:W NEXT								
SHLL.W Rd	R:W NEXT								
SHLL.W #2,Rd	R:W NEXT								
SHLL.L ERd	R:W NEXT								
SHLL.L #2,ERd	R:W NEXT								
SHLR.B Rd	R:W NEXT								
SHLR.B #2,Rd	R:W NEXT								
SHLR.W Rd	R:W NEXT								
SHLR.W #2,Rd	R:W NEXT								
SHLR.L ERd	R:W NEXT								
SHLR.L #2,ERd	R:W NEXT								
SLEEP	R:W NEXT	Internal operation:M							
STC CCR,Rd	R:W NEXT								
STC EXR,Rd	R:W NEXT								
STC CCR,@ERd	R:W 2nd	R:W NEXT	W:W EA						
STC EXR,@ERd	R:W 2nd	R:W NEXT	W:W EA						
STC CCR,@(d:16,ERd)	R:W 2nd	R:W 3rd	R:W NEXT	W:W EA					
STC EXR,@(d:16,ERd)	R:W 2nd	R:W 3rd	R:W NEXT	W:W EA					
STC CCR,@(d:32,ERd)	R:W 2nd	R:W 3rd	R:W 4th	R:W 5th	R:W NEXT	W:W EA			
STC EXR,@(d:32,ERd)	R:W 2nd	R:W 3rd	R:W 4th	R:W 5th	R:W NEXT	W:W EA			
STC CCR,@-ERd	R:W 2nd	R:W NEXT	Internal operation, 1 state	W:W EA					
STC EXR,@-ERd	R:W 2nd	R:W NEXT	Internal operation, 1 state	W:W EA					
STC CCR,@aa:16	R:W 2nd	R:W 3rd	R:W NEXT	W:W EA					
STC EXR,@aa:16	R:W 2nd	R:W 3rd	R:W NEXT	W:W EA					

Instruction	1	2	3	4	5	6	7	8	9
STC CCR,@aa:32	R:W 2nd	R:W 3rd	R:W 4th	R:W NEXT	W:W EA				
STC EXR,@aa:32	R:W 2nd	R:W 3rd	R:W 4th	R:W NEXT	W:W EA				
STM.L(ERn-ERn+1),@_SP*9	R:W 2nd	R:W:M NEXT	Internal operation, 1 state	W:W:M stack (H)*3	W:W stack (L)*3				
STM.L(ERn-ERn+2),@_SP*9	R:W 2nd	R:W:M NEXT	Internal operation, 1 state	W:W:M stack (H)*3	W:W stack (L)*3				
STM.L(ERn-ERn+3),@_SP*9	R:W 2nd	R:W:M NEXT	Internal operation, 1 state	W:W:M stack (H)*3	W:W stack (L)*3				
STMAC MACH.ERd	R:W NEXT								
STMAC MACL.ERd	R:W NEXT								
SUB.B Rs,Rd	R:W NEXT								
SUB.W #xx:16,Rd	R:W 2nd	R:W NEXT							
SUB.W Rs,Rd	R:W NEXT								
SUB.L #xx:32,ERd	R:W 2nd	R:W 3rd	R:W NEXT						
SUB.L ERs,ERd	R:W NEXT								
SUBS #1/2/4,ERd	R:W NEXT								
SUBX #xx:8,Rd	R:W NEXT								
SUBX Rs,Rd	R:W NEXT								
TAS @ERd*8	R:W 2nd	R:W NEXT	R:B:M EA	W:B EA					
TRAPA #x:2	R:W NEXT	Internal operation, 1 state	W:W stack (L)	W:W stack (H)	W:W stack (EXR)	R:W:M VEC	R:W VEC+2	Internal operation, 1 state	R:W*7
XOR.B #xx:8,Rd	R:W NEXT								
XOR.B Rs,Rd	R:W NEXT								
XOR.W #xx:16,Rd	R:W 2nd	R:W NEXT							
XOR.W Rs,Rd	R:W NEXT								
XOR.L #xx:32,ERd	R:W 2nd	R:W 3rd	R:W NEXT						
XOR.L ERs,ERd	R:W 2nd	R:W NEXT							
XORC #xx:8,CCR	R:W NEXT								
XORC #xx:8,EXR	R:W 2nd	R:W NEXT							

Instruction	1	2	3	4	5	6	7	8	9
Reset exception handling	R:W VEC	R:W VEC+2	Internal operation, 1 state	R:W ^{#5}					
Interrupt exception handling	R:W ^{#6}	Internal operation, 1 state	W:W stack (L)	W:W stack (H)	W:W stack (EXR)	R:W:M VEC	R:W VEC+2	Internal operation, 1 state	R:W ^{#7}

Notes: 1. EAs is the contents of ER5. EAd is the contents of ER6.

- EAs is the contents of ER5. EAd is the contents of ER6. Both registers are incremented by 1 after execution of the instruction. n is the initial value of R4L or R4. If n = 0, these bus cycles are not executed.
- Repeated two times to save or restore two registers, three times for three registers, or four times for four registers.
- Start address after return.
- Start address of the program.
- Prefetch address, equal to two plus the PC value pushed onto the stack. In recovery from sleep mode or software standby mode the read operation is replaced by an internal operation.
- Start address of the interrupt-handling routine.
- Only register ER0, ER1, ER4, or ER5 should be used when using the TAS instruction.
- Only register ER0 to ER6 should be used when using the STM/LDM instruction.

A.6 Condition Code Modification

This section indicates the effect of each CPU instruction on the condition code. The notation used in the table is defined below.

$$m = \begin{cases} 31 & \text{for longword operands} \\ 15 & \text{for word operands} \\ 7 & \text{for byte operands} \end{cases}$$

Si	The i-th bit of the source operand
Di	The i-th bit of the destination operand
Ri	The i-th bit of the result
Dn	The specified bit in the destination operand
—	Not affected
↕	Modified according to the result of the instruction (see definition)
0	Always cleared to 0
1	Always set to 1
*	Undetermined (no guaranteed value)
Z'	Z flag before instruction execution
C'	C flag before instruction execution

Table A-7 Condition Code Modification

Instruction	H	N	Z	V	C	Definition
ADD	↓	↓	↓	↓	↓	$H = S_{m-4} \cdot D_{m-4} + D_{m-4} \cdot \overline{R_{m-4}} + S_{m-4} \cdot \overline{R_{m-4}}$ $N = R_m$ $Z = \overline{R_m} \cdot \overline{R_{m-1}} \cdot \dots \cdot \overline{R_0}$ $V = S_m \cdot D_m \cdot \overline{R_m} + \overline{S_m} \cdot \overline{D_m} \cdot R_m$ $C = S_m \cdot D_m + D_m \cdot \overline{R_m} + S_m \cdot \overline{R_m}$
ADDS	—	—	—	—	—	
ADDX	↓	↓	↓	↓	↓	$H = S_{m-4} \cdot D_{m-4} + D_{m-4} \cdot \overline{R_{m-4}} + S_{m-4} \cdot \overline{R_{m-4}}$ $N = R_m$ $Z = Z' \cdot \overline{R_m} \cdot \dots \cdot \overline{R_0}$ $V = S_m \cdot D_m \cdot \overline{R_m} + \overline{S_m} \cdot \overline{D_m} \cdot R_m$ $C = S_m \cdot D_m + D_m \cdot \overline{R_m} + S_m \cdot \overline{R_m}$
AND	—	↓	↓	0	—	$N = R_m$ $Z = \overline{R_m} \cdot \overline{R_{m-1}} \cdot \dots \cdot \overline{R_0}$
ANDC	↓	↓	↓	↓	↓	Stores the corresponding bits of the result. No flags change when the operand is EXR.
BAND	—	—	—	—	↓	$C = C' \cdot D_n$
Bcc	—	—	—	—	—	
BCLR	—	—	—	—	—	
BIAND	—	—	—	—	↓	$C = C' \cdot \overline{D_n}$
BILD	—	—	—	—	↓	$C = \overline{D_n}$
BIOR	—	—	—	—	↓	$C = C' + \overline{D_n}$
BIST	—	—	—	—	—	
BIXOR	—	—	—	—	↓	$C = C' \cdot D_n + \overline{C'} \cdot \overline{D_n}$
BLD	—	—	—	—	↓	$C = D_n$
BNOT	—	—	—	—	—	
BOR	—	—	—	—	↓	$C = C' + D_n$
BSET	—	—	—	—	—	
BSR	—	—	—	—	—	
BST	—	—	—	—	—	
BTST	—	—	↓	—	—	$Z = \overline{D_n}$
BXOR	—	—	—	—	↓	$C = C' \cdot \overline{D_n} + \overline{C'} \cdot D_n$

Instruction	H	N	Z	V	C	Definition
CLRMAC	—	—	—	—	—	
CMP	↕	↕	↕	↕	↕	$H = \overline{S_{m-4}} \cdot \overline{D_{m-4}} + \overline{D_{m-4}} \cdot R_{m-4} + S_{m-4} \cdot R_{m-4}$ $N = R_m$ $Z = \overline{R_m} \cdot \overline{R_{m-1}} \cdot \dots \cdot \overline{R_0}$ $V = \overline{S_m} \cdot D_m \cdot \overline{R_m} + S_m \cdot \overline{D_m} \cdot R_m$ $C = S_m \cdot \overline{D_m} + \overline{D_m} \cdot R_m + S_m \cdot R_m$
DAA	*	↕	↕	*	↕	$N = R_m$ $Z = \overline{R_m} \cdot \overline{R_{m-1}} \cdot \dots \cdot \overline{R_0}$ C: decimal arithmetic carry
DAS	*	↕	↕	*	↕	$N = R_m$ $Z = \overline{R_m} \cdot \overline{R_{m-1}} \cdot \dots \cdot \overline{R_0}$ C: decimal arithmetic borrow
DEC	—	↕	↕	↕	—	$N = R_m$ $Z = \overline{R_m} \cdot \overline{R_{m-1}} \cdot \dots \cdot \overline{R_0}$ $V = D_m \cdot \overline{R_m}$
DIVXS	—	↕	↕	—	—	$N = S_m \cdot \overline{D_m} + \overline{S_m} \cdot D_m$ $Z = \overline{S_m} \cdot \overline{S_{m-1}} \cdot \dots \cdot \overline{S_0}$
DIVXU	—	↕	↕	—	—	$N = S_m$ $Z = \overline{S_m} \cdot \overline{S_{m-1}} \cdot \dots \cdot \overline{S_0}$
EEPMOV	—	—	—	—	—	
EXTS	—	↕	↕	0	—	$N = R_m$ $Z = \overline{R_m} \cdot \overline{R_{m-1}} \cdot \dots \cdot \overline{R_0}$
EXTU	—	0	↕	0	—	$Z = \overline{R_m} \cdot \overline{R_{m-1}} \cdot \dots \cdot \overline{R_0}$
INC	—	↕	↕	↕	—	$N = R_m$ $Z = \overline{R_m} \cdot \overline{R_{m-1}} \cdot \dots \cdot \overline{R_0}$ $V = \overline{D_m} \cdot R_m$
JMP	—	—	—	—	—	
JSR	—	—	—	—	—	
LDC	↕	↕	↕	↕	↕	Stores the corresponding bits of the result. No flags change when the operand is EXR.
LDM	—	—	—	—	—	
LDMAC	—	—	—	—	—	
MAC	—	—	—	—	—	

Instruction	H	N	Z	V	C	Definition
MOV	—	↓	↓	0	—	$N = R_m$ $Z = \overline{R_m} \cdot \overline{R_{m-1}} \cdot \dots \cdot \overline{R_0}$
MOVFPE						Can not be used in this LSI.
MOVTPE						
MULXS	—	↓	↓	—	—	$N = R_{2m}$ $Z = \overline{R_{2m}} \cdot \overline{R_{2m-1}} \cdot \dots \cdot \overline{R_0}$
MULXU	—	—	—	—	—	
NEG	↓	↓	↓	↓	↓	$H = D_{m-4} + R_{m-4}$ $N = R_m$ $Z = \overline{R_m} \cdot \overline{R_{m-1}} \cdot \dots \cdot \overline{R_0}$ $V = D_m \cdot R_m$ $C = D_m + R_m$
NOP	—	—	—	—	—	
NOT	—	↓	↓	0	—	$N = R_m$ $Z = \overline{R_m} \cdot \overline{R_{m-1}} \cdot \dots \cdot \overline{R_0}$
OR	—	↓	↓	0	—	$N = R_m$ $Z = \overline{R_m} \cdot \overline{R_{m-1}} \cdot \dots \cdot \overline{R_0}$
ORC	↓	↓	↓	↓	↓	Stores the corresponding bits of the result. No flags change when the operand is EXR.
POP	—	↓	↓	0	—	$N = R_m$ $Z = \overline{R_m} \cdot \overline{R_{m-1}} \cdot \dots \cdot \overline{R_0}$
PUSH	—	↓	↓	0	—	$N = R_m$ $Z = \overline{R_m} \cdot \overline{R_{m-1}} \cdot \dots \cdot \overline{R_0}$
ROTL	—	↓	↓	0	↓	$N = R_m$ $Z = \overline{R_m} \cdot \overline{R_{m-1}} \cdot \dots \cdot \overline{R_0}$ $C = D_m$ (1-bit shift) or $C = D_{m-1}$ (2-bit shift)
ROTR	—	↓	↓	0	↓	$N = R_m$ $Z = \overline{R_m} \cdot \overline{R_{m-1}} \cdot \dots \cdot \overline{R_0}$ $C = D_0$ (1-bit shift) or $C = D_1$ (2-bit shift)

Instruction	H	N	Z	V	C	Definition
ROTXL	—	↓	↓	0	↓	$N = R_m$ $Z = \overline{R_m} \cdot \overline{R_{m-1}} \cdot \dots \cdot \overline{R_0}$ $C = D_m$ (1-bit shift) or $C = D_{m-1}$ (2-bit shift)
ROTXR	—	↓	↓	0	↓	$N = R_m$ $Z = \overline{R_m} \cdot \overline{R_{m-1}} \cdot \dots \cdot \overline{R_0}$ $C = D_0$ (1-bit shift) or $C = D_1$ (2-bit shift)
RTE	↓	↓	↓	↓	↓	Stores the corresponding bits of the result.
RTS	—	—	—	—	—	
SHAL	—	↓	↓	↓	↓	$N = R_m$ $Z = \overline{R_m} \cdot \overline{R_{m-1}} \cdot \dots \cdot \overline{R_0}$ $V = \overline{D_m \cdot D_{m-1} + \overline{D_m} \cdot \overline{D_{m-1}}}$ (1-bit shift) $V = \overline{D_m \cdot D_{m-1} \cdot D_{m-2} \cdot \overline{D_m} \cdot \overline{D_{m-1}} \cdot \overline{D_{m-2}}}$ (2-bit shift) $C = D_m$ (1-bit shift) or $C = D_{m-1}$ (2-bit shift)
SHAR	—	↓	↓	0	↓	$N = R_m$ $Z = \overline{R_m} \cdot \overline{R_{m-1}} \cdot \dots \cdot \overline{R_0}$ $C = D_0$ (1-bit shift) or $C = D_1$ (2-bit shift)
SHLL	—	↓	↓	0	↓	$N = R_m$ $Z = \overline{R_m} \cdot \overline{R_{m-1}} \cdot \dots \cdot \overline{R_0}$ $C = D_m$ (1-bit shift) or $C = D_{m-1}$ (2-bit shift)
SHLR	—	0	↓	0	↓	$N = R_m$ $Z = \overline{R_m} \cdot \overline{R_{m-1}} \cdot \dots \cdot \overline{R_0}$ $C = D_0$ (1-bit shift) or $C = D_1$ (2-bit shift)
SLEEP	—	—	—	—	—	
STC	—	—	—	—	—	
STM	—	—	—	—	—	
STMAC	—	↓	↓	↓	—	$N = 1$ if MAC instruction resulted in negative value in MAC register $Z = 1$ if MAC instruction resulted in zero value in MAC register $V = 1$ if MAC instruction resulted in overflow

Instruction	H	N	Z	V	C	Definition
SUB	↓	↓	↓	↓	↓	$H = S_{m-4} \cdot \overline{D_{m-4}} + \overline{D_{m-4}} \cdot R_{m-4} + S_{m-4} \cdot R_{m-4}$ $N = R_m$ $Z = \overline{R_m} \cdot \overline{R_{m-1}} \cdot \dots \cdot \overline{R_0}$ $V = \overline{S_m} \cdot D_m \cdot \overline{R_m} + S_m \cdot \overline{D_m} \cdot R_m$ $C = S_m \cdot \overline{D_m} + \overline{D_m} \cdot R_m + S_m \cdot R_m$
SUBS	—	—	—	—	—	
SUBX	↓	↓	↓	↓	↓	$H = S_{m-4} \cdot \overline{D_{m-4}} + \overline{D_{m-4}} \cdot R_{m-4} + S_{m-4} \cdot R_{m-4}$ $N = R_m$ $Z = Z' \cdot \overline{R_m} \cdot \dots \cdot \overline{R_0}$ $V = \overline{S_m} \cdot D_m \cdot \overline{R_m} + S_m \cdot \overline{D_m} \cdot R_m$ $C = S_m \cdot \overline{D_m} + \overline{D_m} \cdot R_m + S_m \cdot R_m$
TAS	—	↓	↓	0	—	$N = D_m$ $Z = \overline{D_m} \cdot \overline{D_{m-1}} \cdot \dots \cdot \overline{D_0}$
TRAPA	—	—	—	—	—	
XOR	—	↓	↓	0	—	$N = R_m$ $Z = \overline{R_m} \cdot \overline{R_{m-1}} \cdot \dots \cdot \overline{R_0}$
XORC	↓	↓	↓	↓	↓	Stores the corresponding bits of the result. No flags change when the operand is EXR.

Appendix B Internal I/O Register

B.1 Address

Address	Register Name	Bit 7	Bit 6	Bit 5	Bit 4	Bit 3	Bit 2	Bit 1	Bit 0	Module Name	Data Bus Width
H'EBC0 to	MRA	SM1	SM0	DM1	DM0	MD1	MD0	DTS	Sz	DTC ^{*7}	8/16/32
H'EFBF	MRB	CHNE	DISEL	—	—	—	—	—	—		
	SAR										
	DAR										
	CRA										
	CRB										
H'F800	MCR0	MCR7	—	MCR5	—	—	MCR2	MCR1	MCR0	HCAN0	8/16
H'F801	GSR0	—	—	—	—	GSR3	GSR2	GSR1	GSR0		
H'F802	BCR0	BCR7	BCR6	BCR5	BCR4	BCR3	BCR2	BCR1	BCR0		
H'F803		BCR15	BCR14	BCR13	BCR12	BCR11	BCR10	BCR9	BCR8		
H'F804	MBCR	MBCR7	MBCR6	MBCR5	MBCR4	MBCR3	MBCR2	MBCR1	—		
H'F805		MBCR15	MBCR14	MBCR13	MBCR12	MBCR11	MBCR10	MBCR9	MBCR8		
H'F806	TXPR	TXPR7	TXPR6	TXPR5	TXPR4	TXPR3	TXPR2	TXPR1	—		
H'F807		TXPR15	TXPR14	TXPR13	TXPR12	TXPR11	TXPR10	TXPR9	TXPR8		
H'F808	TXCR	TXCR7	TXCR6	TXCR5	TXCR4	TXCR3	TXCR2	TXCR1	—		
H'F809		TXCR15	TXCR14	TXCR13	TXCR12	TXCR11	TXCR10	TXCR9	TXCR8		
H'F80A	TXACK	TXACK7	TXACK6	TXACK5	TXACK4	TXACK3	TXACK2	TXACK1	—		
H'F80B		TXACK15	TXACK14	TXACK13	TXACK12	TXACK11	TXACK10	TXACK9	TXACK8		
H'F80C	ABACK	ABACK7	ABACK6	ABACK5	ABACK4	ABACK3	ABACK2	ABACK1	—		
H'F80D		ABACK15	ABACK14	ABACK13	ABACK12	ABACK11	ABACK10	ABACK9	ABACK8		
H'F80E	RXPR	RXPR7	RXPR6	RXPR5	RXPR4	RXPR3	RXPR2	RXPR1	RXPR0		
H'F80F		RXPR15	RXPR14	RXPR13	RXPR12	RXPR11	RXPR10	RXPR9	RXPR8		
H'F810	RFPR	RFPR7	RFPR6	RFPR5	RFPR4	RFPR3	RFPR2	RFPR1	RFPR0	HCAN0	8/16
H'F811		RFPR15	RFPR14	RFPR13	RFPR12	RFPR11	RFPR10	RFPR9	RFPR8		
H'F812	IRR	IRR7	IRR6	IRR5	IRR4	IRR3	IRR2	IRR1	IRR0		
H'F813		—	—	—	IRR12	—	—	IRR9	IRR8		
H'F814	MBIMR	MBIMR7	MBIMR6	MBIMR5	MBIMR4	MBIMR3	MBIMR2	MBIMR1	MBIMR0		
H'F815		MBIMR15	MBIMR14	MBIMR13	MBIMR12	MBIMR11	MBIMR10	MBIMR9	MBIMR8		
H'F816	IMR	IMR7	IMR6	IMR5	IMR4	IMR3	IMR2	IMR1	—		
H'F817		—	—	—	IMR12	—	—	IMR9	IMR8		
H'F818	REC										
H'F819	TEC										

Address	Register Name	Bit 7	Bit 6	Bit 5	Bit 4	Bit 3	Bit 2	Bit 1	Bit 0	Module Name	Data Bus Width
HF81A	UMSR	UMSR7	UMSR6	UMSR5	UMSR4	UMSR3	UMSR2	UMSR1	UMSR0	HCAN0	8/16
HF81B		UMSR15	UMSR14	UMSR13	UMSR12	UMSR11	UMSR10	UMSR9	UMSR8		
HF81C	LAFML	LAFML7	LAFML6	LAFML5	LAFML4	LAFML3	LAFML2	LAFML1	LAFML0		
HF81D		LAFML15	LAFML14	LAFML13	LAFML12	LAFML11	LAFML10	LAFML9	LAFML8		
HF81E	LAFMH	LAFMH7	LAFMH6	LAFMH5	—	—	—	LAFMH1	LAFMH0		
HF81F		LAFMH15	LAFMH14	LAFMH13	LAFMH12	LAFMH11	LAFMH10	LAFMH9	LAFMH8		
HF820	MC0[1]	—	—	—	—	DLC3	DLC2	DLC1	DLC0	HCAN0	8/16
HF821	MC0[2]	—	—	—	—	—	—	—	—		
HF822	MC0[3]	—	—	—	—	—	—	—	—		
HF823	MC0[4]	—	—	—	—	—	—	—	—		
HF824	MC0[5]	STD_ID2	STD_ID1	STD_ID0	RTR	IDE	—	EXD_ID17	EXD_ID16		
HF825	MC0[6]	STD_ID10	STD_ID9	STD_ID8	STD_ID7	STD_ID6	STD_ID5	STD_ID4	STD_ID3		
HF826	MC0[7]	EXD_ID7	EXD_ID6	EXD_ID5	EXD_ID4	EXD_ID3	EXD_ID2	EXD_ID1	EXD_ID0		
HF827	MC0[8]	EXD_ID15	EXD_ID14	EXD_ID13	EXD_ID12	EXD_ID11	EXD_ID10	EXD_ID9	EXD_ID8		
HF828	MC1[1]	—	—	—	—	DLC3	DLC2	DLC1	DLC0		
HF829	MC1[2]	—	—	—	—	—	—	—	—		
HF82A	MC1[3]	—	—	—	—	—	—	—	—		
HF82B	MC1[4]	—	—	—	—	—	—	—	—		
HF82C	MC1[5]	STD_ID2	STD_ID1	STD_ID0	RTR	IDE	—	EXD_ID17	EXD_ID16		
HF82D	MC1[6]	STD_ID10	STD_ID9	STD_ID8	STD_ID7	STD_ID6	STD_ID5	STD_ID4	STD_ID3		
HF82E	MC1[7]	EXD_ID7	EXD_ID6	EXD_ID5	EXD_ID4	EXD_ID3	EXD_ID2	EXD_ID1	EXD_ID0		
HF82F	MC1[8]	EXD_ID15	EXD_ID14	EXD_ID13	EXD_ID12	EXD_ID11	EXD_ID10	EXD_ID9	EXD_ID8		
HF830	MC2[1]	—	—	—	—	DLC3	DLC2	DLC1	DLC0	HCAN0	8/16
HF831	MC2[2]	—	—	—	—	—	—	—	—		
HF832	MC2[3]	—	—	—	—	—	—	—	—		
HF833	MC2[4]	—	—	—	—	—	—	—	—		
HF834	MC2[5]	STD_ID2	STD_ID1	STD_ID0	RTR	IDE	—	EXD_ID17	EXD_ID16		
HF835	MC2[6]	STD_ID10	STD_ID9	STD_ID8	STD_ID7	STD_ID6	STD_ID5	STD_ID4	STD_ID3		
HF836	MC2[7]	EXD_ID7	EXD_ID6	EXD_ID5	EXD_ID4	EXD_ID3	EXD_ID2	EXD_ID1	EXD_ID0		
HF837	MC2[8]	EXD_ID15	EXD_ID14	EXD_ID13	EXD_ID12	EXD_ID11	EXD_ID10	EXD_ID9	EXD_ID8		
HF838	MC3[1]	—	—	—	—	DLC3	DLC2	DLC1	DLC0	HCAN0	8/16
HF839	MC3[2]	—	—	—	—	—	—	—	—		
HF83A	MC3[3]	—	—	—	—	—	—	—	—		
HF83B	MC3[4]	—	—	—	—	—	—	—	—		
HF83C	MC3[5]	STD_ID2	STD_ID1	STD_ID0	RTR	IDE	—	EXD_ID17	EXD_ID16		
HF83D	MC3[6]	STD_ID10	STD_ID9	STD_ID8	STD_ID7	STD_ID6	STD_ID5	STD_ID4	STD_ID3		
HF83E	MC3[7]	EXD_ID7	EXD_ID6	EXD_ID5	EXD_ID4	EXD_ID3	EXD_ID2	EXD_ID1	EXD_ID0		
HF83F	MC3[8]	EXD_ID15	EXD_ID14	EXD_ID13	EXD_ID12	EXD_ID11	EXD_ID10	EXD_ID9	EXD_ID8		

Appendix B Internal I/O Register

Address	Register Name	Bit 7	Bit 6	Bit 5	Bit 4	Bit 3	Bit 2	Bit 1	Bit 0	Module Name	Data Bus Width
H'F840	MC4[1]	—	—	—	—	DLC3	DLC2	DLC1	DLC0	HCAN0	8/16
H'F841	MC4[2]	—	—	—	—	—	—	—	—		
H'F842	MC4[3]	—	—	—	—	—	—	—	—		
H'F843	MC4[4]	—	—	—	—	—	—	—	—		
H'F844	MC4[5]	STD_ID2	STD_ID1	STD_ID0	RTR	IDE	—	EXD_ID17	EXD_ID16		
H'F845	MC4[6]	STD_ID10	STD_ID9	STD_ID8	STD_ID7	STD_ID6	STD_ID5	STD_ID4	STD_ID3		
H'F846	MC4[7]	EXD_ID7	EXD_ID6	EXD_ID5	EXD_ID4	EXD_ID3	EXD_ID2	EXD_ID1	EXD_ID0		
H'F847	MC4[8]	EXD_ID15	EXD_ID14	EXD_ID13	EXD_ID12	EXD_ID11	EXD_ID10	EXD_ID9	EXD_ID8		
H'F848	MC5[1]	—	—	—	—	DLC3	DLC2	DLC1	DLC0	HCAN0	8/16
H'F849	MC5[2]	—	—	—	—	—	—	—	—		
H'F84A	MC5[3]	—	—	—	—	—	—	—	—		
H'F84B	MC5[4]	—	—	—	—	—	—	—	—		
H'F84C	MC5[5]	STD_ID2	STD_ID1	STD_ID0	RTR	IDE	—	EXD_ID17	EXD_ID16		
H'F84D	MC5[6]	STD_ID10	STD_ID9	STD_ID8	STD_ID7	STD_ID6	STD_ID5	STD_ID4	STD_ID3		
H'F84E	MC5[7]	EXD_ID7	EXD_ID6	EXD_ID5	EXD_ID4	EXD_ID3	EXD_ID2	EXD_ID1	EXD_ID0		
H'F84F	MC5[8]	EXD_ID15	EXD_ID14	EXD_ID13	EXD_ID12	EXD_ID11	EXD_ID10	EXD_ID9	EXD_ID8		
H'F850	MC6[1]	—	—	—	—	DLC3	DLC2	DLC1	DLC0	HCAN0	8/16
H'F851	MC6[2]	—	—	—	—	—	—	—	—		
H'F852	MC6[3]	—	—	—	—	—	—	—	—		
H'F853	MC6[4]	—	—	—	—	—	—	—	—		
H'F854	MC6[5]	STD_ID2	STD_ID1	STD_ID0	RTR	IDE	—	EXD_ID17	EXD_ID16		
H'F855	MC6[6]	STD_ID10	STD_ID9	STD_ID8	STD_ID7	STD_ID6	STD_ID5	STD_ID4	STD_ID3		
H'F856	MC6[7]	EXD_ID7	EXD_ID6	EXD_ID5	EXD_ID4	EXD_ID3	EXD_ID2	EXD_ID1	EXD_ID0		
H'F857	MC6[8]	EXD_ID15	EXD_ID14	EXD_ID13	EXD_ID12	EXD_ID11	EXD_ID10	EXD_ID9	EXD_ID8		
H'F858	MC7[1]	—	—	—	—	DLC3	DLC2	DLC1	DLC0		
H'F859	MC7[2]	—	—	—	—	—	—	—	—		
H'F85A	MC7[3]	—	—	—	—	—	—	—	—		
H'F85B	MC7[4]	—	—	—	—	—	—	—	—		
H'F85C	MC7[5]	STD_ID2	STD_ID1	STD_ID0	RTR	IDE	—	EXD_ID17	EXD_ID16		
H'F85D	MC7[6]	STD_ID10	STD_ID9	STD_ID8	STD_ID7	STD_ID6	STD_ID5	STD_ID4	STD_ID3		
H'F85E	MC7[7]	EXD_ID7	EXD_ID6	EXD_ID5	EXD_ID4	EXD_ID3	EXD_ID2	EXD_ID1	EXD_ID0		
H'F85F	MC7[8]	EXD_ID15	EXD_ID14	EXD_ID13	EXD_ID12	EXD_ID11	EXD_ID10	EXD_ID9	EXD_ID8		
H'F860	MC8[1]	—	—	—	—	DLC3	DLC2	DLC1	DLC0	HCAN0	8/16
H'F861	MC8[2]	—	—	—	—	—	—	—	—		
H'F862	MC8[3]	—	—	—	—	—	—	—	—		
H'F863	MC8[4]	—	—	—	—	—	—	—	—		
H'F864	MC8[5]	STD_ID2	STD_ID1	STD_ID0	RTR	IDE	—	EXD_ID17	EXD_ID16		
H'F865	MC8[6]	STD_ID10	STD_ID9	STD_ID8	STD_ID7	STD_ID6	STD_ID5	STD_ID4	STD_ID3		
H'F866	MC8[7]	EXD_ID7	EXD_ID6	EXD_ID5	EXD_ID4	EXD_ID3	EXD_ID2	EXD_ID1	EXD_ID0		
H'F867	MC8[8]	EXD_ID15	EXD_ID14	EXD_ID13	EXD_ID12	EXD_ID11	EXD_ID10	EXD_ID9	EXD_ID8		

Address	Register Name	Bit 7	Bit 6	Bit 5	Bit 4	Bit 3	Bit 2	Bit 1	Bit 0	Module Name	Data Bus Width
HF868	MC9[1]	—	—	—	—	DLC3	DLC2	DLC1	DLC0	HCAN0	8/16
HF869	MC9[2]	—	—	—	—	—	—	—	—		
HF86A	MC9[3]	—	—	—	—	—	—	—	—		
HF86B	MC9[4]	—	—	—	—	—	—	—	—		
HF86C	MC9[5]	STD_ID2	STD_ID1	STD_ID0	RTR	IDE	—	EXD_ID17	EXD_ID16		
HF86D	MC9[6]	STD_ID10	STD_ID9	STD_ID8	STD_ID7	STD_ID6	STD_ID5	STD_ID4	STD_ID3		
HF86E	MC9[7]	EXD_ID7	EXD_ID6	EXD_ID5	EXD_ID4	EXD_ID3	EXD_ID2	EXD_ID1	EXD_ID0		
HF86F	MC9[8]	EXD_ID15	EXD_ID14	EXD_ID13	EXD_ID12	EXD_ID11	EXD_ID10	EXD_ID9	EXD_ID8		
HF870	MC10[1]	—	—	—	—	DLC3	DLC2	DLC1	DLC0	HCAN0	8/16
HF871	MC10[2]	—	—	—	—	—	—	—	—		
HF872	MC10[3]	—	—	—	—	—	—	—	—		
HF873	MC10[4]	—	—	—	—	—	—	—	—		
HF874	MC10[5]	STD_ID2	STD_ID1	STD_ID0	RTR	IDE	—	EXD_ID17	EXD_ID16		
HF875	MC10[6]	STD_ID10	STD_ID9	STD_ID8	STD_ID7	STD_ID6	STD_ID5	STD_ID4	STD_ID3		
HF876	MC10[7]	EXD_ID7	EXD_ID6	EXD_ID5	EXD_ID4	EXD_ID3	EXD_ID2	EXD_ID1	EXD_ID0		
HF877	MC10[8]	EXD_ID15	EXD_ID14	EXD_ID13	EXD_ID12	EXD_ID11	EXD_ID10	EXD_ID9	EXD_ID8		
HF878	MC11[1]	—	—	—	—	DLC3	DLC2	DLC1	DLC0		
HF879	MC11[2]	—	—	—	—	—	—	—	—		
HF87A	MC11[3]	—	—	—	—	—	—	—	—		
HF87B	MC11[4]	—	—	—	—	—	—	—	—		
HF87C	MC11[5]	STD_ID2	STD_ID1	STD_ID0	RTR	IDE	—	EXD_ID17	EXD_ID16		
HF87D	MC11[6]	STD_ID10	STD_ID9	STD_ID8	STD_ID7	STD_ID6	STD_ID5	STD_ID4	STD_ID3		
HF87E	MC11[7]	EXD_ID7	EXD_ID6	EXD_ID5	EXD_ID4	EXD_ID3	EXD_ID2	EXD_ID1	EXD_ID0		
HF87F	MC11[8]	EXD_ID15	EXD_ID14	EXD_ID13	EXD_ID12	EXD_ID11	EXD_ID10	EXD_ID9	EXD_ID8		
HF880	MC12[1]	—	—	—	—	DLC3	DLC2	DLC1	DLC0	HCAN0	8/16
HF881	MC12[2]	—	—	—	—	—	—	—	—		
HF882	MC12[3]	—	—	—	—	—	—	—	—		
HF883	MC12[4]	—	—	—	—	—	—	—	—		
HF884	MC12[5]	STD_ID2	STD_ID1	STD_ID0	RTR	IDE	—	EXD_ID17	EXD_ID16		
HF885	MC12[6]	STD_ID10	STD_ID9	STD_ID8	STD_ID7	STD_ID6	STD_ID5	STD_ID4	STD_ID3		
HF886	MC12[7]	EXD_ID7	EXD_ID6	EXD_ID5	EXD_ID4	EXD_ID3	EXD_ID2	EXD_ID1	EXD_ID0		
HF887	MC12[8]	EXD_ID15	EXD_ID14	EXD_ID13	EXD_ID12	EXD_ID11	EXD_ID10	EXD_ID9	EXD_ID8		
HF888	MC13[1]	—	—	—	—	DLC3	DLC2	DLC1	DLC0	HCAN0	8/16
HF889	MC13[2]	—	—	—	—	—	—	—	—		
HF88A	MC13[3]	—	—	—	—	—	—	—	—		
HF88B	MC13[4]	—	—	—	—	—	—	—	—		
HF88C	MC13[5]	STD_ID2	STD_ID1	STD_ID0	RTR	IDE	—	EXD_ID17	EXD_ID16		
HF88D	MC13[6]	STD_ID10	STD_ID9	STD_ID8	STD_ID7	STD_ID6	STD_ID5	STD_ID4	STD_ID3		
HF88E	MC13[7]	EXD_ID7	EXD_ID6	EXD_ID5	EXD_ID4	EXD_ID3	EXD_ID2	EXD_ID1	EXD_ID0		
HF88F	MC13[8]	EXD_ID15	EXD_ID14	EXD_ID13	EXD_ID12	EXD_ID11	EXD_ID10	EXD_ID9	EXD_ID8		

Appendix B Internal I/O Register

Address	Register Name	Bit 7	Bit 6	Bit 5	Bit 4	Bit 3	Bit 2	Bit 1	Bit 0	Module Name	Data Bus Width
H'F890	MC14[1]	—	—	—	—	DLC3	DLC2	DLC1	DLC0	HCAN0	8/16
H'F891	MC14[2]	—	—	—	—	—	—	—	—		
H'F892	MC14[3]	—	—	—	—	—	—	—	—		
H'F893	MC14[4]	—	—	—	—	—	—	—	—		
H'F894	MC14[5]	STD_ID2	STD_ID1	STD_ID0	RTR	IDE	—	EXD_ID17	EXD_ID16		
H'F895	MC14[6]	STD_ID10	STD_ID9	STD_ID8	STD_ID7	STD_ID6	STD_ID5	STD_ID4	STD_ID3		
H'F896	MC14[7]	EXD_ID7	EXD_ID6	EXD_ID5	EXD_ID4	EXD_ID3	EXD_ID2	EXD_ID1	EXD_ID0		
H'F897	MC14[8]	EXD_ID15	EXD_ID14	EXD_ID13	EXD_ID12	EXD_ID11	EXD_ID10	EXD_ID9	EXD_ID8		
H'F898	MC15[1]	—	—	—	—	DLC3	DLC2	DLC1	DLC0		
H'F899	MC15[2]	—	—	—	—	—	—	—	—		
H'F89A	MC15[3]	—	—	—	—	—	—	—	—		
H'F89B	MC15[4]	—	—	—	—	—	—	—	—		
H'F89C	MC15[5]	STD_ID2	STD_ID1	STD_ID0	RTR	IDE	—	EXD_ID17	EXD_ID16		
H'F89D	MC15[6]	STD_ID10	STD_ID9	STD_ID8	STD_ID7	STD_ID6	STD_ID5	STD_ID4	STD_ID3		
H'F89E	MC15[7]	EXD_ID7	EXD_ID6	EXD_ID5	EXD_ID4	EXD_ID3	EXD_ID2	EXD_ID1	EXD_ID0		
H'F89F	MC15[8]	EXD_ID15	EXD_ID14	EXD_ID13	EXD_ID12	EXD_ID11	EXD_ID10	EXD_ID9	EXD_ID8		
H'F8B0	MD01									HCAN0	8/16
H'F8B1	MD02										
H'F8B2	MD03										
H'F8B3	MD04										
H'F8B4	MD05										
H'F8B5	MD06										
H'F8B6	MD07										
H'F8B7	MD08										
H'F8B8	MD11									HCAN0	8/16
H'F8B9	MD12										
H'F8BA	MD13										
H'F8BB	MD14										
H'F8BC	MD15										
H'F8BD	MD16										
H'F8BE	MD17										
H'F8BF	MD18										
H'F8C0	MD21									HCAN0	8/16
H'F8C1	MD22										
H'F8C2	MD23										
H'F8C3	MD24										
H'F8C4	MD25										
H'F8C5	MD26										
H'F8C6	MD27										
H'F8C7	MD28										

Address	Register Name	Bit 7	Bit 6	Bit 5	Bit 4	Bit 3	Bit 2	Bit 1	Bit 0	Module Name	Data Bus Width
H'F8C8	MD31									HCAN0	8/16
H'F8C9	MD32										
H'F8CA	MD33										
H'F8CB	MD34										
H'F8CC	MD35										
H'F8CD	MD36										
H'F8CE	MD37										
H'F8CF	MD38										
H'F8D0	MD41									HCAN0	8/16
H'F8D1	MD42										
H'F8D2	MD43										
H'F8D3	MD44										
H'F8D4	MD45										
H'F8D5	MD46										
H'F8D6	MD47										
H'F8D7	MD48										
H'F8D8	MD51									HCAN0	8/16
H'F8D9	MD52										
H'F8DA	MD53										
H'F8DB	MD54										
H'F8DC	MD55										
H'F8DD	MD56										
H'F8DE	MD57										
H'F8DF	MD58										
H'F8E0	MD61									HCAN0	8/16
H'F8E1	MD62										
H'F8E2	MD63										
H'F8E3	MD64										
H'F8E4	MD65										
H'F8E5	MD66										
H'F8E6	MD67										
H'F8E7	MD68										
H'F8E8	MD71									HCAN0	8/16
H'F8E9	MD72										
H'F8EA	MD73										
H'F8EB	MD74										
H'F8EC	MD75										
H'F8ED	MD76										
H'F8EE	MD77										
H'F8EF	MD78										

Appendix B Internal I/O Register

Address	Register Name	Bit 7	Bit 6	Bit 5	Bit 4	Bit 3	Bit 2	Bit 1	Bit 0	Module Name	Data Bus Width
H'F8F0	MD81									HCAN0	8/16
H'F8F1	MD82										
H'F8F2	MD83										
H'F8F3	MD84										
H'F8F4	MD85										
H'F8F5	MD86										
H'F8F6	MD87										
H'F8F7	MD88										
H'F8F8	MD91									HCAN0	8/16
H'F8F9	MD92										
H'F8FA	MD93										
H'F8FB	MD94										
H'F8FC	MD95										
H'F8FD	MD96										
H'F8FE	MD97										
H'F8FF	MD98										
H'F900	MD101									HCAN0	8/16
H'F901	MD102										
H'F902	MD103										
H'F903	MD104										
H'F904	MD105										
H'F905	MD106										
H'F906	MD107										
H'F907	MD108										
H'F908	MD111									HCAN0	8/16
H'F909	MD112										
H'F90A	MD113										
H'F90B	MD114										
H'F90C	MD115										
H'F90D	MD116										
H'F90E	MD117										
H'F90F	MD118										
H'F910	MD121									HCAN0	8/16
H'F911	MD122										
H'F912	MD123										
H'F913	MD124										
H'F914	MD125										
H'F915	MD126										
H'F916	MD127										
H'F917	MD128										

Address	Register Name	Bit 7	Bit 6	Bit 5	Bit 4	Bit 3	Bit 2	Bit 1	Bit 0	Module Name	Data Bus Width
H'F918	MD131									HCAN0	8/16
H'F919	MD132										
H'F91A	MD133										
H'F91B	MD134										
H'F91C	MD135										
H'F91D	MD136										
H'F91E	MD137										
H'F91F	MD138										
H'F920	MD141									HCAN0	8/16
H'F921	MD142										
H'F922	MD143										
H'F923	MD144										
H'F924	MD145										
H'F925	MD146										
H'F926	MD147										
H'F927	MD148										
H'F928	MD151										
H'F929	MD152										
H'F92A	MD153										
H'F92B	MD154										
H'F92C	MD155										
H'F92D	MD156										
H'F92E	MD157										
H'F92F	MD158										
H'FA00	MCR	MCR7	—	MCR5	—	—	MCR2	MCR1	MCR0	HCAN1*7	8/16
H'FA01	GSR	—	—	—	—	GSR3	GSR2	GSR1	GSR0		
H'FA02	BCR	BCR7	BCR6	BCR5	BCR4	BCR3	BCR2	BCR1	BCR0		
H'FA03		BCR15	BCR14	BCR13	BCR12	BCR11	BCR10	BCR9	BCR8		
H'FA04	MBCR	MBCR7	MBCR6	MBCR5	MBCR4	MBCR3	MBCR2	MBCR1	—		
H'FA05		MBCR15	MBCR14	MBCR13	MBCR12	MBCR11	MBCR10	MBCR9	MBCR8		
H'FA06	TXPR	TXPR7	TXPR6	TXPR5	TXPR4	TXPR3	TXPR2	TXPR1	—		
H'FA07		TXPR15	TXPR14	TXPR13	TXPR12	TXPR11	TXPR10	TXPR9	TXPR8		
H'FA08	TXCR	TXCR7	TXCR6	TXCR5	TXCR4	TXCR3	TXCR2	TXCR1	—		
H'FA09		TXCR15	TXCR14	TXCR13	TXCR12	TXCR11	TXCR10	TXCR9	TXCR8		
H'FA0A	TXACK	TXACK7	TXACK6	TXACK5	TXACK4	TXACK3	TXACK2	TXACK1	—		
H'FA0B		TXACK15	TXACK14	TXACK13	TXACK12	TXACK11	TXACK10	TXACK9	TXACK8		
H'FA0C	ABACK	ABACK7	ABACK6	ABACK5	ABACK4	ABACK3	ABACK2	ABACK1	—		
H'FA0D		ABACK15	ABACK14	ABACK13	ABACK12	ABACK11	ABACK10	ABACK9	ABACK8		
H'FA0E	RXPR	RXPR7	RXPR6	RXPR5	RXPR4	RXPR3	RXPR2	RXPR1	RXPR0		
H'FA0F		RXPR15	RXPR14	RXPR13	RXPR12	RXPR11	RXPR10	RXPR9	RXPR8		

Appendix B Internal I/O Register

Address	Register									Module Name	Data Bus Width
	Name	Bit 7	Bit 6	Bit 5	Bit 4	Bit 3	Bit 2	Bit 1	Bit 0		
H'FA10	RFPR	RFPR7	RFPR6	RFPR5	RFPR4	RFPR3	RFPR2	RFPR1	RFPR0	HCAN1*7	8/16
H'FA11		RFPR15	RFPR14	RFPR13	RFPR12	RFPR11	RFPR10	RFPR9	RFPR8		
H'FA12	IRR	IRR7	IRR6	IRR5	IRR4	IRR3	IRR2	IRR1	IRR0		
H'FA13		—	—	—	IRR12	—	—	IRR9	IRR8		
H'FA14	MBIMR	MBIMR7	MBIMR6	MBIMR5	MBIMR4	MBIMR3	MBIMR2	MBIMR1	MBIMR0		
H'FA15		MBIMR15	MBIMR14	MBIMR13	MBIMR12	MBIMR11	MBIMR10	MBIMR9	MBIMR8		
H'FA16	IMR	IMR7	IMR6	IMR5	IMR4	IMR3	IMR2	IMR1	IMR0		
H'FA17		—	—	—	IMR12	—	—	IMR9	IMR8		
H'FA18	REC										
H'FA19	TEC										
H'FA1A	UMSR	UMSR7	UMSR6	UMSR5	UMSR4	UMSR3	UMSR2	UMSR1	UMSR0		
H'FA1B		UMSR15	UMSR14	UMSR13	UMSR12	UMSR11	UMSR10	UMSR9	UMSR8		
H'FA1C	LAFML	LAFML7	LAFML6	LAFML5	LAFML4	LAFML3	LAFML2	LAFML1	LAFML0		
H'FA1D		LAFML15	LAFML14	LAFML13	LAFML12	LAFML11	LAFML10	LAFML9	LAFML8		
H'FA1E	LAFMH	LAFMH7	LAFMH6	LAFMH5	—	—	—	LAFMH1	LAFMH0		
H'FA1F		LAFMH15	LAFMH14	LAFMH13	LAFMH12	LAFMH11	LAFMH10	LAFMH9	LAFMH8		
H'FA20	MC0[1]	—	—	—	—	DLC3	DLC2	DLC1	DLC0	HCAN1*7	8/16
H'FA21	MC0[2]	—	—	—	—	—	—	—	—		
H'FA22	MC0[3]	—	—	—	—	—	—	—	—		
H'FA23	MC0[4]	—	—	—	—	—	—	—	—		
H'FA24	MC0[5]	STD_ID2	STD_ID1	STD_ID0	RTR	IDE	—	EXD_ID17	EXD_ID16		
H'FA25	MC0[6]	STD_ID10	STD_ID9	STD_ID8	STD_ID7	STD_ID6	STD_ID5	STD_ID4	STD_ID3		
H'FA26	MC0[7]	EXD_ID7	EXD_ID6	EXD_ID5	EXD_ID4	EXD_ID3	EXD_ID2	EXD_ID1	EXD_ID0		
H'FA27	MC0[8]	EXD_ID15	EXD_ID14	EXD_ID13	EXD_ID12	EXD_ID11	EXD_ID10	EXD_ID9	EXD_ID8		
H'FA28	MC1[1]	—	—	—	—	DLC3	DLC2	DLC1	DLC0		
H'FA29	MC1[2]	—	—	—	—	—	—	—	—		
H'FA2A	MC1[3]	—	—	—	—	—	—	—	—		
H'FA2B	MC1[4]	—	—	—	—	—	—	—	—		
H'FA2C	MC1[5]	STD_ID2	STD_ID1	STD_ID0	RTR	IDE	—	EXD_ID17	EXD_ID16		
H'FA2D	MC1[6]	STD_ID10	STD_ID9	STD_ID8	STD_ID7	STD_ID6	STD_ID5	STD_ID4	STD_ID3		
H'FA2E	MC1[7]	EXD_ID7	EXD_ID6	EXD_ID5	EXD_ID4	EXD_ID3	EXD_ID2	EXD_ID1	EXD_ID0		
H'FA2F	MC1[8]	EXD_ID15	EXD_ID14	EXD_ID13	EXD_ID12	EXD_ID11	EXD_ID10	EXD_ID9	EXD_ID8		
H'FA30	MC2[1]	—	—	—	—	DLC3	DLC2	DLC1	DLC0	HCAN1*7	8/16
H'FA31	MC2[2]	—	—	—	—	—	—	—	—		
H'FA32	MC2[3]	—	—	—	—	—	—	—	—		
H'FA33	MC2[4]	—	—	—	—	—	—	—	—		
H'FA34	MC2[5]	STD_ID2	STD_ID1	STD_ID0	RTR	IDE	—	EXD_ID17	EXD_ID16		
H'FA35	MC2[6]	STD_ID10	STD_ID9	STD_ID8	STD_ID7	STD_ID6	STD_ID5	STD_ID4	STD_ID3		
H'FA36	MC2[7]	EXD_ID7	EXD_ID6	EXD_ID5	EXD_ID4	EXD_ID3	EXD_ID2	EXD_ID1	EXD_ID0		
H'FA37	MC2[8]	EXD_ID15	EXD_ID14	EXD_ID13	EXD_ID12	EXD_ID11	EXD_ID10	EXD_ID9	EXD_ID8		
H'FA38	MC3[1]	—	—	—	—	DLC3	DLC2	DLC1	DLC0		
H'FA39	MC3[2]	—	—	—	—	—	—	—	—		

Address	Register									Module Name	Data Bus Width
	Register Name	Bit 7	Bit 6	Bit 5	Bit 4	Bit 3	Bit 2	Bit 1	Bit 0		
HFA3A	MC3[3]	—	—	—	—	—	—	—	—	HCAN1*7	8/16
HFA3B	MC3[4]	—	—	—	—	—	—	—	—		
HFA3C	MC3[5]	STD_ID2	STD_ID1	STD_ID0	RTR	IDE	—	EXD_ID17	EXD_ID16		
HFA3D	MC3[6]	STD_ID10	STD_ID9	STD_ID8	STD_ID7	STD_ID6	STD_ID5	STD_ID4	STD_ID3		
HFA3E	MC3[7]	EXD_ID7	EXD_ID6	EXD_ID5	EXD_ID4	EXD_ID3	EXD_ID2	EXD_ID1	EXD_ID0		
HFA3F	MC3[8]	EXD_ID15	EXD_ID14	EXD_ID13	EXD_ID12	EXD_ID11	EXD_ID10	EXD_ID9	EXD_ID8		
HFA40	MC4[1]	—	—	—	—	DLC3	DLC2	DLC1	DLC0	HCAN1*7	8/16
HFA41	MC4[2]	—	—	—	—	—	—	—	—		
HFA42	MC4[3]	—	—	—	—	—	—	—	—		
HFA43	MC4[4]	—	—	—	—	—	—	—	—		
HFA44	MC4[5]	STD_ID2	STD_ID1	STD_ID0	RTR	IDE	—	EXD_ID17	EXD_ID16		
HFA45	MC4[6]	STD_ID10	STD_ID9	STD_ID8	STD_ID7	STD_ID6	STD_ID5	STD_ID4	STD_ID3		
HFA46	MC4[7]	EXD_ID7	EXD_ID6	EXD_ID5	EXD_ID4	EXD_ID3	EXD_ID2	EXD_ID1	EXD_ID0		
HFA47	MC4[8]	EXD_ID15	EXD_ID14	EXD_ID13	EXD_ID12	EXD_ID11	EXD_ID10	EXD_ID9	EXD_ID8		
HFA48	MC5[1]	—	—	—	—	DLC3	DLC2	DLC1	DLC0		
HFA49	MC5[2]	—	—	—	—	—	—	—	—		
HFA4A	MC5[3]	—	—	—	—	—	—	—	—		
HFA4B	MC5[4]	—	—	—	—	—	—	—	—		
HFA4C	MC5[5]	STD_ID2	STD_ID1	STD_ID0	RTR	IDE	—	EXD_ID17	EXD_ID16		
HFA4D	MC5[6]	STD_ID10	STD_ID9	STD_ID8	STD_ID7	STD_ID6	STD_ID5	STD_ID4	STD_ID3		
HFA4E	MC5[7]	EXD_ID7	EXD_ID6	EXD_ID5	EXD_ID4	EXD_ID3	EXD_ID2	EXD_ID1	EXD_ID0		
HFA4F	MC5[8]	EXD_ID15	EXD_ID14	EXD_ID13	EXD_ID12	EXD_ID11	EXD_ID10	EXD_ID9	EXD_ID8		
HFA50	MC6[1]	—	—	—	—	DLC3	DLC2	DLC1	DLC0	HCAN1*7	8/16
HFA51	MC6[2]	—	—	—	—	—	—	—	—		
HFA52	MC6[3]	—	—	—	—	—	—	—	—		
HFA53	MC6[4]	—	—	—	—	—	—	—	—		
HFA54	MC6[5]	STD_ID2	STD_ID1	STD_ID0	RTR	IDE	—	EXD_ID17	EXD_ID16		
HFA55	MC6[6]	STD_ID10	STD_ID9	STD_ID8	STD_ID7	STD_ID6	STD_ID5	STD_ID4	STD_ID3		
HFA56	MC6[7]	EXD_ID7	EXD_ID6	EXD_ID5	EXD_ID4	EXD_ID3	EXD_ID2	EXD_ID1	EXD_ID0		
HFA57	MC6[8]	EXD_ID15	EXD_ID14	EXD_ID13	EXD_ID12	EXD_ID11	EXD_ID10	EXD_ID9	EXD_ID8		
HFA58	MC7[1]	—	—	—	—	DLC3	DLC2	DLC1	DLC0		
HFA59	MC7[2]	—	—	—	—	—	—	—	—		
HFA5A	MC7[3]	—	—	—	—	—	—	—	—		
HFA5B	MC7[4]	—	—	—	—	—	—	—	—		
HFA5C	MC7[5]	STD_ID2	STD_ID1	STD_ID0	RTR	IDE	—	EXD_ID17	EXD_ID16		
HFA5D	MC7[6]	STD_ID10	STD_ID9	STD_ID8	STD_ID7	STD_ID6	STD_ID5	STD_ID4	STD_ID3		
HFA5E	MC7[7]	EXD_ID7	EXD_ID6	EXD_ID5	EXD_ID4	EXD_ID3	EXD_ID2	EXD_ID1	EXD_ID0		
HFA5F	MC7[8]	EXD_ID15	EXD_ID14	EXD_ID13	EXD_ID12	EXD_ID11	EXD_ID10	EXD_ID9	EXD_ID8		

Appendix B Internal I/O Register

Address	Register									Module Name	Data Bus Width
	Name	Bit 7	Bit 6	Bit 5	Bit 4	Bit 3	Bit 2	Bit 1	Bit 0		
H'FA60	MC8[1]	—	—	—	—	DLC3	DLC2	DLC1	DLC0	HCAN1*7	8/16
H'FA61	MC8[2]	—	—	—	—	—	—	—	—		
H'FA62	MC8[3]	—	—	—	—	—	—	—	—		
H'FA63	MC8[4]	—	—	—	—	—	—	—	—		
H'FA64	MC8[5]	STD_ID2	STD_ID1	STD_ID0	RTR	IDE	—	EXD_ID17	EXD_ID16		
H'FA65	MC8[6]	STD_ID10	STD_ID9	STD_ID8	STD_ID7	STD_ID6	STD_ID5	STD_ID4	STD_ID3		
H'FA66	MC8[7]	EXD_ID7	EXD_ID6	EXD_ID5	EXD_ID4	EXD_ID3	EXD_ID2	EXD_ID1	EXD_ID0		
H'FA67	MC8[8]	EXD_ID15	EXD_ID14	EXD_ID13	EXD_ID12	EXD_ID11	EXD_ID10	EXD_ID9	EXD_ID8		
H'FA68	MC9[1]	—	—	—	—	DLC3	DLC2	DLC1	DLC0		
H'FA69	MC9[2]	—	—	—	—	—	—	—	—		
H'FA6A	MC9[3]	—	—	—	—	—	—	—	—		
H'FA6B	MC9[4]	—	—	—	—	—	—	—	—		
H'FA6C	MC9[5]	STD_ID2	STD_ID1	STD_ID0	RTR	IDE	—	EXD_ID17	EXD_ID16		
H'FA6D	MC9[6]	STD_ID10	STD_ID9	STD_ID8	STD_ID7	STD_ID6	STD_ID5	STD_ID4	STD_ID3		
H'FA6E	MC9[7]	EXD_ID7	EXD_ID6	EXD_ID5	EXD_ID4	EXD_ID3	EXD_ID2	EXD_ID1	EXD_ID0		
H'FA6F	MC9[8]	EXD_ID15	EXD_ID14	EXD_ID13	EXD_ID12	EXD_ID11	EXD_ID10	EXD_ID9	EXD_ID8		
H'FA70	MC10[1]	—	—	—	—	DLC3	DLC2	DLC1	DLC0	HCAN1*7	8/16
H'FA71	MC10[2]	—	—	—	—	—	—	—	—		
H'FA72	MC10[3]	—	—	—	—	—	—	—	—		
H'FA73	MC10[4]	—	—	—	—	—	—	—	—		
H'FA74	MC10[5]	STD_ID2	STD_ID1	STD_ID0	RTR	IDE	—	EXD_ID17	EXD_ID16		
H'FA75	MC10[6]	STD_ID10	STD_ID9	STD_ID8	STD_ID7	STD_ID6	STD_ID5	STD_ID4	STD_ID3		
H'FA76	MC10[7]	EXD_ID7	EXD_ID6	EXD_ID5	EXD_ID4	EXD_ID3	EXD_ID2	EXD_ID1	EXD_ID0		
H'FA77	MC10[8]	EXD_ID15	EXD_ID14	EXD_ID13	EXD_ID12	EXD_ID11	EXD_ID10	EXD_ID9	EXD_ID8		
H'FA78	MC11[1]	—	—	—	—	DLC3	DLC2	DLC1	DLC0		
H'FA79	MC11[2]	—	—	—	—	—	—	—	—		
H'FA7A	MC11[3]	—	—	—	—	—	—	—	—		
H'FA7B	MC11[4]	—	—	—	—	—	—	—	—		
H'FA7C	MC11[5]	STD_ID2	STD_ID1	STD_ID0	RTR	IDE	—	EXD_ID17	EXD_ID16		
H'FA7D	MC11[6]	STD_ID10	STD_ID9	STD_ID8	STD_ID7	STD_ID6	STD_ID5	STD_ID4	STD_ID3		
H'FA7E	MC11[7]	EXD_ID7	EXD_ID6	EXD_ID5	EXD_ID4	EXD_ID3	EXD_ID2	EXD_ID1	EXD_ID0		
H'FA7F	MC11[8]	EXD_ID15	EXD_ID14	EXD_ID13	EXD_ID12	EXD_ID11	EXD_ID10	EXD_ID9	EXD_ID8		
H'FA80	MC12[1]	—	—	—	—	DLC3	DLC2	DLC1	DLC0	HCAN1*7	8/16
H'FA81	MC12[2]	—	—	—	—	—	—	—	—		
H'FA82	MC12[3]	—	—	—	—	—	—	—	—		
H'FA83	MC12[4]	—	—	—	—	—	—	—	—		
H'FA84	MC12[5]	STD_ID2	STD_ID1	STD_ID0	RTR	IDE	—	EXD_ID17	EXD_ID16		
H'FA85	MC12[6]	STD_ID10	STD_ID9	STD_ID8	STD_ID7	STD_ID6	STD_ID5	STD_ID4	STD_ID3		
H'FA86	MC12[7]	EXD_ID7	EXD_ID6	EXD_ID5	EXD_ID4	EXD_ID3	EXD_ID2	EXD_ID1	EXD_ID0		
H'FA87	MC12[8]	EXD_ID15	EXD_ID14	EXD_ID13	EXD_ID12	EXD_ID11	EXD_ID10	EXD_ID9	EXD_ID8		
H'FA88	MC13[1]	—	—	—	—	DLC3	DLC2	DLC1	DLC0		
H'FA89	MC13[2]	—	—	—	—	—	—	—	—		

Address	Register									Module Name	Data Bus Width
	Register Name	Bit 7	Bit 6	Bit 5	Bit 4	Bit 3	Bit 2	Bit 1	Bit 0		
H'FA8A	MC13[3]	—	—	—	—	—	—	—	—	HCAN1*7	8/16
H'FA8B	MC13[4]	—	—	—	—	—	—	—	—		
H'FA8C	MC13[5]	STD_ID2	STD_ID1	STD_ID0	RTR	IDE	—	EXD_ID17	EXD_ID16		
H'FA8D	MC13[6]	STD_ID10	STD_ID9	STD_ID8	STD_ID7	STD_ID6	STD_ID5	STD_ID4	STD_ID3		
H'FA8E	MC13[7]	EXD_ID7	EXD_ID6	EXD_ID5	EXD_ID4	EXD_ID3	EXD_ID2	EXD_ID1	EXD_ID0		
H'FA8F	MC13[8]	EXD_ID15	EXD_ID14	EXD_ID13	EXD_ID12	EXD_ID11	EXD_ID10	EXD_ID9	EXD_ID8		
H'FA90	MC14[1]	—	—	—	—	DLC3	DLC2	DLC1	DLC0	HCAN1*7	8/16
H'FA91	MC14[2]	—	—	—	—	—	—	—	—		
H'FA92	MC14[3]	—	—	—	—	—	—	—	—		
H'FA93	MC14[4]	—	—	—	—	—	—	—	—		
H'FA94	MC14[5]	STD_ID2	STD_ID1	STD_ID0	RTR	IDE	—	EXD_ID17	EXD_ID16		
H'FA95	MC14[6]	STD_ID10	STD_ID9	STD_ID8	STD_ID7	STD_ID6	STD_ID5	STD_ID4	STD_ID3		
H'FA96	MC14[7]	EXD_ID7	EXD_ID6	EXD_ID5	EXD_ID4	EXD_ID3	EXD_ID2	EXD_ID1	EXD_ID0		
H'FA97	MC14[8]	EXD_ID15	EXD_ID14	EXD_ID13	EXD_ID12	EXD_ID11	EXD_ID10	EXD_ID9	EXD_ID8		
H'FA98	MC15[1]	—	—	—	—	DLC3	DLC2	DLC1	DLC0		
H'FA99	MC15[2]	—	—	—	—	—	—	—	—		
H'FA9A	MC15[3]	—	—	—	—	—	—	—	—		
H'FA9B	MC15[4]	—	—	—	—	—	—	—	—		
H'FA9C	MC15[5]	STD_ID2	STD_ID1	STD_ID0	RTR	IDE	—	EXD_ID17	EXD_ID16		
H'FA9D	MC15[6]	STD_ID10	STD_ID9	STD_ID8	STD_ID7	STD_ID6	STD_ID5	STD_ID4	STD_ID3		
H'FA9E	MC15[7]	EXD_ID7	EXD_ID6	EXD_ID5	EXD_ID4	EXD_ID3	EXD_ID2	EXD_ID1	EXD_ID0		
H'FA9F	MC15[8]	EXD_ID15	EXD_ID14	EXD_ID13	EXD_ID12	EXD_ID11	EXD_ID10	EXD_ID9	EXD_ID8		
H'FAB0	MD01									HCAN1*7	8/16
H'FAB1	MD02										
H'FAB2	MD03										
H'FAB3	MD04										
H'FAB4	MD05										
H'FAB5	MD06										
H'FAB6	MD07										
H'FAB7	MD08										
H'FAB8	MD11										
H'FAB9	MD12										
H'FABA	MD13										
H'FABB	MD14										
H'FABC	MD15										
H'FABD	MD16										
H'FABE	MD17										
H'FABF	MD18										

Appendix B Internal I/O Register

Address	Register										Module Name	Data Bus Width
	Name	Bit 7	Bit 6	Bit 5	Bit 4	Bit 3	Bit 2	Bit 1	Bit 0			
H'FAC0	MD21										HCAN1*7	8/16
H'FAC1	MD22											
H'FAC2	MD23											
H'FAC3	MD24											
H'FAC4	MD25											
H'FAC5	MD26											
H'FAC6	MD27											
H'FAC7	MD28											
H'FAC8	MD31											
H'FAC9	MD32											
H'FACA	MD33											
H'FACB	MD34											
H'FACC	MD35											
H'FACD	MD36											
H'FACE	MD37											
H'FACF	MD38											
H'FAD0	MD41										HCAN1*7	8/16
H'FAD1	MD42											
H'FAD2	MD43											
H'FAD3	MD44											
H'FAD4	MD45											
H'FAD5	MD46											
H'FAD6	MD47											
H'FAD7	MD48											
H'FAD8	MD51											
H'FAD9	MD52											
H'FADA	MD53											
H'FADB	MD54											
H'FADC	MD55											
H'FADD	MD56											
H'FADE	MD57											
H'FADF	MD58											
H'FAE0	MD61										HCAN1*7	8/16
H'FAE1	MD62											
H'FAE2	MD63											
H'FAE3	MD64											
H'FAE4	MD65											
H'FAE5	MD66											
H'FAE6	MD67											
H'FAE7	MD68											
H'FAE8	MD71											
H'FAE9	MD72											

Address	Register									Module Name	Data Bus Width	
	Name	Bit 7	Bit 6	Bit 5	Bit 4	Bit 3	Bit 2	Bit 1	Bit 0			
H'FAEA	MD73										HCAN1*7	8/16
H'FAEB	MD74											
H'FAEC	MD75											
H'FAED	MD76											
H'FAEE	MD77											
H'FAEF	MD78											
H'FAF0	MD81										HCAN1*7	8/16
H'FAF1	MD82											
H'FAF2	MD83											
H'FAF3	MD84											
H'FAF4	MD85											
H'FAF5	MD86											
H'FAF6	MD87											
H'FAF7	MD88											
H'FAF8	MD91											
H'FAF9	MD92											
H'FAFA	MD93											
H'FAFB	MD94											
H'FAFC	MD95											
H'FAFD	MD96											
H'FAFE	MD97											
H'FAFF	MD98											
H'FB00	MD101										HCAN1*7	8/16
H'FB01	MD102											
H'FB02	MD103											
H'FB03	MD104											
H'FB04	MD105											
H'FB05	MD106											
H'FB06	MD107											
H'FB07	MD108											
H'FB08	MD111											
H'FB09	MD112											
H'FB0A	MD113											
H'FB0B	MD114											
H'FB0C	MD115											
H'FB0D	MD116											
H'FB0E	MD117											
H'FB0F	MD118											

Appendix B Internal I/O Register

Address	Register										Module Name	Data Bus Width		
	Name	Bit 7	Bit 6	Bit 5	Bit 4	Bit 3	Bit 2	Bit 1	Bit 0					
H'FB10	MD121										HCAN1*7	8/16		
H'FB11	MD122													
H'FB12	MD123													
H'FB13	MD124													
H'FB14	MD125													
H'FB15	MD126													
H'FB16	MD127													
H'FB17	MD128													
H'FB18	MD131													
H'FB19	MD132													
H'FB1A	MD133													
H'FB1B	MD134													
H'FB1C	MD135													
H'FB1D	MD136													
H'FB1E	MD137													
H'FB1F	MD138													
H'FB20	MD141												HCAN1*7	8/16
H'FB21	MD142													
H'FB22	MD143													
H'FB23	MD144													
H'FB24	MD145													
H'FB25	MD146													
H'FB26	MD147													
H'FB27	MD148													
H'FB28	MD151													
H'FB29	MD152													
H'FB2A	MD153													
H'FB2B	MD154													
H'FB2C	MD155													
H'FB2D	MD156													
H'FB2E	MD157													
H'FB2F	MD158													

Address	Register									Module Name	Data Bus Width		
	Name	Bit 7	Bit 6	Bit 5	Bit 4	Bit 3	Bit 2	Bit 1	Bit 0				
H'FC00	PWCR1	—	—	IE	CMF	CST	CKS2	CKS1	CKS0	Motor control PWM timer 1	16		
H'FC02	PWOCR1	OE1H	OE1G	OE1F	OE1E	OE1D	OE1C	OE1B	OE1A				
H'FC04	PWPR1	OPS1H	OPS1G	OPS1F	OPS1E	OPS1D	OPS1C	OPS1B	OPS1A				
H'FC06	PWCYR1	—	—	—	—	—	—	—	—				
H'FC08	PWBFR1A	—	—	—	OTS	—	—	DT9	DT8	Motor control PWM timer 2	16		
		DT7	DT6	DT5	DT4	DT3	DT2	DT1	DT0				
H'FC0A	PWBFR1C	—	—	—	OTS	—	—	DT9	DT8				
		DT7	DT6	DT5	DT4	DT3	DT2	DT1	DT0				
H'FC0C	PWBFR1E	—	—	—	OTS	—	—	DT9	DT8				
		DT7	DT6	DT5	DT4	DT3	DT2	DT1	DT0				
H'FC0E	PWBFR1G	—	—	—	OTS	—	—	DT9	DT8				
		DT7	DT6	DT5	DT4	DT3	DT2	DT1	DT0				
H'FC10	PWCR2	—	—	IE	CMF	CST	CKS2	CKS1	CKS0			Motor control PWM timer 2	16
H'FC12	PWOCR2	OE2H	OE2G	OE2F	OE2E	OE2D	OE2C	OE2B	OE2A				
H'FC14	PWPR2	OPS2H	OPS2G	OPS2F	OPS2E	OPS2D	OPS2C	OPS2B	OPS2A				
H'FC16	PWCYR2	—	—	—	—	—	—	—	—				
H'FC18	PWBFR2A	—	—	—	TDS	—	—	DT9	DT8	PORT	16		
		DT7	DT6	DT5	DT4	DT3	DT2	DT1	DT0				
H'FC1A	PWBFR2B	—	—	—	TDS	—	—	DT9	DT8				
		DT7	DT6	DT5	DT4	DT3	DT2	DT1	DT0				
H'FC1C	PWBFR2C	—	—	—	TDS	—	—	DT9	DT8				
		DT7	DT6	DT5	DT4	DT3	DT2	DT1	DT0				
H'FC1E	PWBFR2D	—	—	—	TDS	—	—	DT9	DT8				
		DT7	DT6	DT5	DT4	DT3	DT2	DT1	DT0				
H'FC20	PHDDR	PH7DDR	PH6DDR	PH5DDR	PH4DDR	PH3DDR	PH2DDR	PH1DDR	PH0DDR			PORT	16
H'FC21	PJDDR	PJ7DDR	PJ6DDR	PJ5DDR	PJ4DDR	PJ3DDR	PJ2DDR	PJ1DDR	PJ0DDR				
H'FC24	PHDR	PH7DR	PH6DR	PH5DR	PH4DR	PH3DR	PH2DR	PH1DR	PH0DR				
H'FC25	PJDR	PJ7DR	PJ6DR	PJ5DR	PJ4DR	PJ3DR	PJ2DR	PJ1DR	PJ0DR				
H'FC28	PORTH	PH7	PH6	PH5	PH4	PH3	PH2	PH1	PH0				
H'FC29	PORTJ	PJ7	PJ6	PJ5	PJ4	PJ3	PJ2	PJ1	PJ0				

Appendix B Internal I/O Register

Address	Register									Module Name	Data Bus Width
	Name	Bit 7	Bit 6	Bit 5	Bit 4	Bit 3	Bit 2	Bit 1	Bit 0		
H'FC60	MSTPCRD	MSTPD7	—	—	—	—	—	—	—	SYSTEM	8
H'FDB4	SCKX ^{*4}	—	IICX1	IICX0	IICE	—	—	—	—	IIC ^{*4}	8
H'FDB5	DDCSWR ^{*4}	SWE	SW	IE	IF	CLR3	CLR2	CLR1	CLR0		
H'FDE4	SBYCR	SSBY	STS2	STS1	STS0	OPE	—	—	—	SYSTEM	8
H'FDE5	SYSCR	MACS	—	INTM1	INTM0	NMIEG	—	—	RAME		
H'FDE6	SCKCR	PSTOP	—	—	—	STCS	SCK2	SCK1	SCK0		
H'FDE7	MDCR	—	—	—	—	—	MDS2	MDS1	MDS1		
H'FDE8	MSTPCRA	MSTPA7	MSTPA6	MSTPA5	MSTPA4	MSTPA3	MSTPA2	MSTPA1	MSTPA0		
H'FDE9	MSTPCRB	MSTPB7	MSTPB6	MSTPB5	MSTPB4	MSTPB3	MSTPB2	MSTPB1	MSTPB0		
H'FDEA	MSTPCRC	MSTPC7	MSTPC6	MSTPC5	MSTPC4	MSTPC3	MSTPC2	MSTPC1	MSTPC0		
H'FDEB	PFCR	—	—	—	—	AE3	AE2	AE1	AE0		
H'FDEC	LPWRRCR	DTON ^{*3}	LSON ^{*3}	NESEL ^{*3}	SUBSTP ^{*3}	RFCUT ^{*3}	—	STC1	STC0		
H'FE00	BARA	—	—	—	—	—	—	—	—	PBC ^{*7}	8
H'FE01		BAA23	BAA22	BAA21	BAA20	BAA19	BAA18	BAA17	BAA16		
H'FE02		BAA15	BAA14	BAA13	BAA12	BAA11	BAA10	BAA9	BAA8		
H'FE03		BAA7	BAA6	BAA5	BAA4	BAA3	BAA2	BAA1	BAA0		
H'FE04	BARB	—	—	—	—	—	—	—	—		
H'FE05		BAA23	BAA22	BAA21	BAA20	BAA19	BAA18	BAA17	BAA16		
H'FE06		BAA15	BAA14	BAA13	BAA12	BAA11	BAA10	BAA9	BAA8		
H'FE07		BAA7	BAA6	BAA5	BAA4	BAA3	BAA2	BAA1	BAA0		
H'FE08	BCRA	CMFA	CDA	BAMRA2	BAMRA1	BAMRA0	CSELA1	CSELA0	BIEA		
H'FE09	BCRB	CMFA	CDA	BAMRA2	BAMRA1	BAMRA0	CSELA1	CSELA0	BIEA		
H'FE12	ISCRH	—	—	—	—	IRQ5SCB	IRQ5SCA	IRQ4SCB	IRQ4SCA	INT	8
H'FE13	ISCR L	IRQ3SCB	IRQ3SCA	IRQ2SCB	IRQ2SCA	IRQ1SCB	IRQ1SCA	IRQ0SCB	IRQ0SCA		
H'FE14	IER	—	—	IRQ5E	IRQ4E	IRQ3E	IRQ2E	IRQ1E	IRQ0E		
H'FE15	ISR	—	—	IRQ5F	IRQ4F	IRQ3F	IRQ2F	IRQ1F	IRQ0F		
H'FE16	DTCERA	DTCEA7	DTCEA6	DTCEA5	DTCEA4	DTCEA3	DTCEA2	DTCEA1	DTCEA0	DTC ^{*7}	8
H'FE17	DTCERB	DTCEB7	DTCEB6	DTCEB5	DTCEB4	DTCEB3	DTCEB2	DTCEB1	DTCEB0		
H'FE18	DTCERC	DTCEC7	DTCEC6	DTCEC5	DTCEC4	DTCEC3	DTCEC2	DTCEC1	DTCEC0		
H'FE19	DTCERD	DTCED7	DTCED6	DTCED5	DTCED4	DTCED3	DTCED2	DTCED1	DTCED0		
H'FE1A	DTCERE	DTCEE7	DTCEE6	DTCEE5	DTCEE4	DTCEE3	DTCEE2	DTCEE1	DTCEE0		
H'FE1B	DTCERF	DTCEF7	DTCEF6	DTCEF5	DTCEF4	DTCEF3	DTCEF2	DTCEF1	DTCEF0		
H'FE1C	DTCERG	DTCEG7	DTCEG6	DTCEG5	DTCEG4	DTCEG3	DTCEG2	DTCEG1	DTCEG0		
H'FE1F	DTVECR	SWDTE	DTVEC6	DTVEC5	DTVEC4	DTVEC3	DTVEC2	DTVEC1	DTVEC0		
H'FE26	PCR	G3CMS1	G3CMS0	G2CMS1	G2CMS0	G1CMS1	G1CMS0	G0CMS1	G0CMS0	PPG ^{*7}	8
H'FE27	PMR	G3INV	G2INV	G1INV	G0INV	G3NOV	G2NOV	G1NOV	G0NOV		
H'FE28	NDERH	NDER15	NDER14	NDER13	NDER12	NDER11	NDER10	NDER9	NDER8		
H'FE29	NDERL	NDER7	NDER6	NDER5	NDER4	NDER3	NDER2	NDER1	NDER0		
H'FE2A	PODRH	POD15	POD14	POD13	POD12	POD11	POD10	POD9	POD8		
H'FE2B	PODR L	POD7	POD6	POD5	POD4	POD3	POD2	POD1	POD0		
H'FE2C	NDRH	NDR15	NDR14	NDR13	NDR12	NDR11	NDR10	NDR9	NDR8		
H'FE2D	NDR L	NDR7	NDR6	NDR5	NDR4	NDR3	NDR2	NDR1	NDR0		

Address	Register									Module Name	Data Bus Width
	Name	Bit 7	Bit 6	Bit 5	Bit 4	Bit 3	Bit 2	Bit 1	Bit 0		
H'FE2E	NDRH	—	—	—	—	NDR11	NDR10	NDR9	NDR8	PPG ^{*/7}	8
H'FE2F	NDRL	—	—	—	—	NDR3	NDR2	NDR1	NDR0		
H'FE30	P1DDR	P17DDR	P16DDR	P15DDR	P14DDR	P13DDR	P12DDR	P11DDR	P10DDR	PORT	8
H'FE32	P3DDR	—	—	P35DDR	P34DDR	P33DDR	P32DDR	P31DDR	P30DDR		
H'FE39	PADDR	—	—	—	—	PA3DDR	PA2DDR	PA1DDR	PA0DDR		
H'FE3A	PBDDR	PB7DDR	PB6DDR	PB5DDR	PB4DDR	PB3DDR	PB2DDR	PB1DDR	PB0DDR		
H'FE3B	PCDDR	PC7DDR	PC6DDR	PC5DDR	PC4DDR	PC3DDR	PC2DDR	PC1DDR	PC0DDR		
H'FE3C	PDDDR	PD7DDR	PD6DDR	PD5DDR	PD4DDR	PD3DDR	PD2DDR	PD1DDR	PD0DDR		
H'FE3D	PEDDR	PE7DDR	PE6DDR	PE5DDR	PE4DDR	PE3DDR	PE2DDR	PE1DDR	PE0DDR		
H'FE3E	PFDDR	PF7DDR	PF6DDR	PF5DDR	PF4DDR	PF3DDR	—	—	PF0DDR		
H'FE40	PAPCR	—	—	—	—	PA3PCR	PA2PCR	PA1PCR	PA0PCR	PORT	8
H'FE41	PBPCR	PB7PCR	PB6PCR	PB5PCR	PB4PCR	PB3PCR	PB2PCR	PB1PCR	PB0PCR		
H'FE42	PCPCR	PC7PCR	PC6PCR	PC5PCR	PC4PCR	PC3PCR	PC2PCR	PC1PCR	PC0PCR		
H'FE43	PDPCR	PD7PCR	PD6PCR	PD5PCR	PD4PCR	PD3PCR	PD2PCR	PD1PCR	PD0PCR		
H'FE44	PEPCR	PE7PCR	PE6PCR	PE5PCR	PE4PCR	PE3PCR	PE2PCR	PE1PCR	PE0PCR		
H'FE46	P3ODR	—	—	P35ODR	P34ODR	P33ODR	P32ODR	P31ODR	P30ODR		
H'FE47	PAODR	—	—	—	—	PA3ODR	PA2ODR	PA1ODR	PA0ODR		
H'FE48	PBODR	PB7ODR	PB6ODR	PB5ODR	PB4ODR	PB3ODR	PB2ODR	PB1ODR	PB0ODR		
H'FE49	PCODR	PC7ODR	PC6ODR	PC5ODR	PC4ODR	PC3ODR	PC2ODR	PC1ODR	PC0ODR		
H'FE80	TCR3	CCLR2	CCLR1	CCLR0	CKEG1	CKEG0	TPSC2	TPSC1	TPSC0	TPU3	8/16
H'FE81	TMDR3	—	—	BFB	BFA	MD3	MD2	MD1	MD0		
H'FE82	TIOR3H	IOB3	IOB2	IOB1	IOB0	IOA3	IOA2	IOA1	IOA0		
H'FE83	TIOR3L	IOD3	IOD2	IOD1	IOD0	IOC3	IOC2	IOC1	IOC0		
H'FE84	TIER3	TTGE	—	—	TCIEV	TGIED	TGIEC	TGIEB	TGIEA		
H'FE85	TSR3	—	—	—	TCFV	TGFD	TGFC	TGFB	TGFA		
H'FE86	TCNT3										
H'FE87											
H'FE88	TGR3A										
H'FE89											
H'FE8A	TGR3B										
H'FE8B											
H'FE8C	TGR3C										
H'FE8D											
H'FE8E	TGR3D										
H'FE8F											
H'FE90	TCR4	—	CCLR1	CCLR0	CKEG1	CKEG0	TPSC2	TPSC1	TPSC0	TPU4	8/16
H'FE91	TMDR4	—	—	—	—	MD3	MD2	MD1	MD0		
H'FE92	TIOR4	IOB3	IOB2	IOB1	IOB0	IOA3	IOA2	IOA1	IOA0		
H'FE94	TIER4	TTGE	—	—	TCIEU	TCIEV	—	—	TGIEB	TGIEA	
H'FE95	TSR4	TCFD	—	—	TCFU	TCFV	—	—	TGFB	TGFA	

Appendix B Internal I/O Register

Address	Register									Module Name	Data Bus Width
	Name	Bit 7	Bit 6	Bit 5	Bit 4	Bit 3	Bit 2	Bit 1	Bit 0		
H'FE96	TCNT4									TPU4	8/16
H'FE97											
H'FE98	TGR4A										
H'FE99											
H'FE9A	TGR4B										
H'FE9B											
H'FEA0	TCR5	—	CCLR1	CCLR0	CKEG1	CKEG0	TPSC2	TPSC1	TPSC0	TPU5	8/16
H'FEA1	TMDR5	—	—	—	—	MD3	MD2	MD1	MD0		
H'FEA2	TIOR5	IOB3	IOB2	IOB1	IOB0	IOA3	IOA2	IOA1	IOA0		
H'FEA4	TIER5	TTGE	—	TCIEU	TCIEV	—	—	TGIEB	TGIEA		
H'FEA5	TSR5	TCFD	—	TCFU	TCFV	—	—	TGFB	TGFA		
H'FEA6	TCNT5										
H'FEA7											
H'FEA8	TGR5A										
H'FEA9											
H'FEAA	TGR5B										
H'FEAB											
H'FEB0	TSTR	—	—	CST5	CST4	CST3	CST2	CST1	CST0	TPU All	8
H'FEB1	TSYR	—	—	SYNC5	SYNC4	SYNC3	SYNC2	SYNC1	SYNC0		
H'FEC0	IPRA	—	IPR6	IPR5	IPR4	—	IPR2	IPR1	IPR0	INT	8
H'FEC1	IPRB	—	IPR6	IPR5	IPR4	—	IPR2	IPR1	IPR0		
H'FEC2	IPRC	—	—	—	—	—	IPR2 ^{*7}	IPR1 ^{*7}	IPR0 ^{*7}		
H'FEC3	IPRD	—	IPR6	IPR5	IPR4	—	—	—	—		
H'FEC4	IPRE	—	IPR6 ^{*7}	IPR5 ^{*7}	IPR4 ^{*7}	—	IPR2	IPR1	IPR0		
H'FEC5	IPRF	—	IPR6	IPR5	IPR4	—	IPR2	IPR1	IPR0		
H'FEC6	IPRG	—	IPR6	IPR5	IPR4	—	IPR2	IPR1	IPR0		
H'FEC7	IPRH	—	IPR6	IPR5	IPR4	—	IPR2	IPR1	IPR0		
H'FEC9	IPRJ	—	—	—	—	—	IPR2	IPR1	IPR0		
H'FECA	IPRK	—	IPR6	IPR5	IPR4	—	IPR2	IPR1	IPR0		
H'FECC	IPRM	—	IPR6	IPR5	IPR4	—	IPR2	IPR1	IPR0		
H'FECE	Reserved										
H'FED0	ABWCR	ABW7	ABW6	ABW5	ABW4	ABW3	ABW2	ABW1	ABW0	Bus controller	8
H'FED1	ASTCR	AST7	AST6	AST5	AST4	AST3	AST2	AST1	AST0		
H'FED2	WCRH	W71	W70	W61	W60	W51	W50	W41	W40		
H'FED3	WCRL	W31	W30	W21	W20	W11	W10	W01	W00		
H'FED4	BCRH	ICIS1	ICIS0	BRSTRM	BRSTS1	BRSTS0	—	—	—		
H'FED5	BCRL	—	—	—	—	—	—	WDBE	—		
H'FEDB	RAMER	—	—	—	—	RAMS	RAM2	RAM1	RAM0	ROM	8
H'FF00	P1DR	P17DR	P16DR	P15DR	P14DR	P13DR	P12DR	P11DR	P10DR	PORT	8
H'FF02	P3DR	—	—	P35DR	P34DR	P33DR	P32DR	P31DR	P30DR		
H'FF09	PADR	—	—	—	—	PA3DR	PA2DR	PA1DR	PA0DR		

Address	Register									Module Name	Data Bus Width		
	Name	Bit 7	Bit 6	Bit 5	Bit 4	Bit 3	Bit 2	Bit 1	Bit 0				
H'FF0A	PBDR	PB7DR	PB6DR	PB5DR	PB4DR	PB3DR	PB2DR	PB1DR	PB0DR	PORT	8		
H'FF0B	PCDR	PC7DR	PC6DR	PC5DR	PC4DR	PC3DR	PC2DR	PC1DR	PC0DR				
H'FF0C	PDDR	PD7DR	PD6DR	PD5DR	PD4DR	PD3DR	PD2DR	PD1DR	PD0DR				
H'FF0D	PEDR	PE7DR	PE6DR	PE5DR	PE4DR	PE3DR	PE2DR	PE1DR	PE0DR				
H'FF0E	PFDR	PF7DR	PF6DR	PF5DR	PF4DR	PF3DR	—	—	PF0DR				
H'FF10	TCR0	CCLR2	CCLR1	CCLR0	CKEG1	CKEG0	TPSC2	TPSC1	TPSC0			TPU0	8/16
H'FF11	TMDR0	—	—	BFB	BFA	MD3	MD2	MD1	MD0				
H'FF12	TIOR0H	IOB3	IOB2	IOB1	IOB0	IOA3	IOA2	IOA1	IOA0				
H'FF13	TIOR0L	IOD3	IOD2	IOD1	IOD0	IOC3	IOC2	IOC1	IOC0				
H'FF14	TIER0	TTGE	—	—	TCIEV	TGIED	TGIEC	TGIEB	TGIEA				
H'FF15	TSR0	—	—	—	TCFV	TGFD	TGFC	TGFB	TGFA				
H'FF16	TNCT0												
H'FF17													
H'FF18	TGR0A												
H'FF19													
H'FF1A	TGR0B												
H'FF1B													
H'FF1C	TGR0C												
H'FF1D													
H'FF1E	TGR0D												
H'FF1F													
H'FF20	TCR1	—	CCLR1	CCLR0	CKEG1	CKEG0	TPSC2	TPSC1	TPSC0	TPU1	8/16		
H'FF21	TMDR1	—	—	—	—	MD3	MD2	MD1	MD0				
H'FF22	TIOR1	IOB3	IOB2	IOB1	IOB0	IOA3	IOA2	IOA1	IOA0				
H'FF24	TIER1	TTGE	—	TCIEU	TCIEV	—	—	TGIEB	TGIEA				
H'FF25	TSR1	TCFD	—	TCFU	TCFV	—	—	TGFB	TGFA				
H'FF26	TNCT1												
H'FF27													
H'FF28	TGR1A												
H'FF29													
H'FF2A	TGR1B												
H'FF2B													
H'FF30	TCR2	—	CCLR1	CCLR0	CKEG1	CKEG0	TPSC2	TPSC1	TPSC0			TPU2	8/16
H'FF31	TMDR2	—	—	—	—	MD3	MD2	MD1	MD0				
H'FF32	TIOR2	IOB3	IOB2	IOB1	IOB0	IOA3	IOA2	IOA1	IOA0				
H'FF34	TIER2	TTGE	—	TCIEU	TCIEV	—	—	TGIEB	TGIEA				
H'FF35	TSR2	TCFD	—	TCFU	TCFV	—	—	TGFB	TGFA				
H'FF36	TNCT2												
H'FF37													
H'FF38	TGR2A												
H'FF39													
H'FF3A	TGR2B												
H'FF3B													

Appendix B Internal I/O Register

Address	Register									Module Name	Data Bus Width
	Name	Bit 7	Bit 6	Bit 5	Bit 4	Bit 3	Bit 2	Bit 1	Bit 0		
H'FF74 (read/write)	TCSR0	OVF	WT/IT	TME	—	—	CKS2	CKS1	CKS0	WDT0	8
H'FF75 (read)	TCNT0	—	—	—	—	—	—	—	—	—	—
H'FF76	—	—	—	—	—	—	—	—	—	—	—
H'FF77 (read)	RSTCSR0	WOVF	RSTE	—	—	—	—	—	—	—	—
H'FF78	SMR0	C/A	CHR	PE	O/E	STOP	MP	CKS1	CKS0	SC10, IIC0 ^{*4} , Smart card interface 0	8
	SMR0	GM	BLK	PE	O/E	BCP1	BCP0	CKS1	CKS0		
	ICCR0 ^{*4}	ICE	IEIC	MST	TRS	ACKE	BBSY	IRIC	SCP		
H'FF79	BRR0	—	—	—	—	—	—	—	—	—	—
	ICSR0 ^{*4}	ESTP	STOP	IRTR	AASX	AL	AAS	ADZ	ACKB	—	—
H'FF7A	SCR0	TIE	RIE	TE	RE	MPIE	TEIE	CKE1	CKE0	—	—
H'FF7B	TDR0	—	—	—	—	—	—	—	—	—	—
H'FF7C	SSR0	TDRE	RDRF	ORER	FER	PER	TEND	MPB	MPBT	—	—
	SSR0	TDRE	RDRF	ORER	ERS	PER	TEND	MPB	MPBT	—	—
H'FF7D	RDR0	—	—	—	—	—	—	—	—	—	—
H'FF7E	SCMR0	—	—	—	—	SDIR	SINV	—	SMIF	—	—
	ICDR0/ SARX0 ^{*4}	ICDR7/ SVAX6	ICDR6/ SVAX5	ICDR5/ SVAX4	ICDR4/ SVAX3	ICDR3/ SVAX2	ICDR2/ SVAX1	ICDR1/ SVAX0	ICDR0/FSX	—	—
H'FF7F	ICMR0/ SAR0	MLS/ SVA6	WAIT/ SVA5	CKS2/ SVA4	CKS1/ SVA3	CKS0/ SVA2	BC2/ SVA1	BC1/ SVA0	BC0/FS	IIC0 ^{*4}	—
H'FF80	SMR1	C/A	CHR	PE	O/E	STOP	MP	CKS1	CKS0	SC11, IIC1 ^{*4} , Smart card interface 1	8
	SMR1	GM	BLK	PE	O/E	BCP1	BCP0	CKS1	CKS0		
	ICCR1 ^{*4}	ICE	IEIC	MST	TRS	ACKE	BBSY	IRIC	SCP		
H'FF81	BRR1	—	—	—	—	—	—	—	—	—	—
	ICSR1 ^{*4}	ESTP	STOP	IRTR	AASX	AL	AAS	ADZ	ACKB	—	—
H'FF82	SCR1	TIE	RIE	TE	RE	MPIE	TEIE	CKE1	CKE0	—	—
H'FF83	TDR1	—	—	—	—	—	—	—	—	—	—
H'FF84	SSR1	TDRE	RDRF	ORER	FER	PER	TEND	MPB	MPBT	—	—
	SSR1	TDRE	RDRF	ORER	ERS	PER	TEND	MPB	MPBT	—	—
H'FF85	RDR1	—	—	—	—	—	—	—	—	—	—
H'FF86	SCMR1	—	—	—	—	SDIR	SINV	—	SMIF	—	—
	ICDR1/ SARX1 ^{*4}	ICDR7/ SVARX6	ICDR6/ SVARX5	ICDR5/ SVARX4	ICDR4/ SVARX3	ICDR3/ SVARX2	ICDR2/ SVARX1	ICDR1/ SVARX0	ICDR0/FSX	—	—
H'FF87	ICMR1/ SAR1 ^{*4}	MLS/ SVA6	WAIT/ SVA5	CKS2/ SVA4	CKS1/ SVA3	CKS0/ SVA2	BC2/ SVA1	BC1/ SVA0	BC0/FS	IIC1 ^{*4}	—
H'FF88	SMR2	C/A	CHR	PE	O/E	STOP	MP	CKS1	CKS0	SC12, Smart card interface 2	8
	SMR2	GM	BLK	PE	O/E	BCP1	BCP0	CKS1	CKS0		
H'FF89	BRR2	—	—	—	—	—	—	—	—	—	—
H'FF8A	SCR2	TIE	RIE	TE	RE	MPIE	TEIE	CKE1	CKE0	—	—
H'FF8B	TDR2	—	—	—	—	—	—	—	—	—	—
H'FF8C	SSR2	TDRE	RDRF	ORER	FER	PER	TEND	MPB	MPBT	—	—
	SSR2	TDRE	RDRF	ORER	ERS	PER	TEND	MPB	MPBT	—	—
H'FF8D	RDR2	—	—	—	—	—	—	—	—	—	—
H'FF8E	SCMR2	—	—	—	—	SDIR	SINV	—	SMIF	—	—

Address	Register									Module Name	Data Bus Width
	Name	Bit 7	Bit 6	Bit 5	Bit 4	Bit 3	Bit 2	Bit 1	Bit 0		
H'FF90	ADDRAH	AD9	AD8	AD7	AD6	AD5	AD4	AD3	AD2	A/D	8
H'FF91	ADDRAL	AD1	AD0	—	—	—	—	—	—		
H'FF92	ADDRBH	AD9	AD8	AD7	AD6	AD5	AD4	AD3	AD2		
H'FF93	ADDRBL	AD1	AD0	—	—	—	—	—	—		
H'FF94	ADDRCH	AD9	AD8	AD7	AD6	AD5	AD4	AD3	AD2		
H'FF95	ADDRCL	AD1	AD0	—	—	—	—	—	—		
H'FF96	ADDRDH	AD9	AD8	AD7	AD6	AD5	AD4	AD3	AD2		
H'FF97	ADDRDL	AD1	AD0	—	—	—	—	—	—		
H'FF98	ADCSR	ADF	ADIE	ADST	SCAN	CH3	CH2	CH1	CH0		
H'FF99	ADCR	TRGS1	TRGS0	—	—	CKS1	CKS0	—	—		
H'FFA2 (read/write)	TCSR1	OVF	WT/IT	TME	PSS*1	RST/NMI	CKS2	CKS1	CKS0	WDT1	16
H'FFA3 (read)	TCNT1										
H'FFA4	DADRO									D/A0, 1	8
H'FFA5	DADR1										
H'FFA6	DACR01	DAOE1	DAOE0	DAE	—	—	—	—	—		
H'FFA8	FLMCR1	FWE	SWE	ESU	PSU	EV	PV	E	P	FLASH	8
H'FFA9	FLMCR2	FLER	—	—	—	—	—	—	—		
H'FFAA	EBR1	EB7	EB6	EB5	EB4	EB3	EB2	EB1	EB0		
H'FFAB	EBR2	—	—	EB13*8	EB12*8	EB11*6	EB10*5	EB9	EB8		
H'FFAC	FLPWCR	PDWND*2	—	—	—	—	—	—	—		
H'FFB0	PORT1	P17	P16	P15	P14	P13	P12	P11	P10	PORT	8
H'FFB2	PORT3	—	—	P35	P34	P33	P32	P31	P30		
H'FFB3	PORT4	P47	P46	P45	P44	P43	P42	P41	P40		
H'FFB8	PORT9	—	—	—	—	P93	P92	P91	P90		
H'FFB9	PORTA	—	—	—	—	PA3	PA2	PA1	PA0		
H'FFBA	PORTB	PB7	PB6	PB5	PB4	PB3	PB2	PB1	PB0		
H'FFBB	PORTC	PC7	PC6	PC5	PC4	PC3	PC2	PC1	PC0		
H'FFBC	PORTD	PD7	PD6	PD5	PD4	PD3	PD2	PD1	PD0		
H'FFBD	PORTE	PE7	PE6	PE5	PE4	PE3	PE2	PE1	PE0		
H'FFBE	PORTF	PF7	PF6	PF5	PF4	PF3	—	—	PF0		

- Notes:
1. Bit 4 (PSS) in TCSR of WDT1 is valid in the U-mask and W-mask versions, and H8S/2635 Group. In versions other than the U-mask and W-mask versions, and H8S/2635 Group, however, the PSS bit must always be written with 0 since no subclock functions are available.
 2. Subclock functions (subactive mode, subsleep mode, and watch mode) are not available in versions other than the U-mask and W-mask versions, and H8S/2635 Group. Subclock functions may be used with the U-mask and W-mask versions, and H8S/2635 Group.
 3. Bits DTON, LSON, NESEL, and SUBSTP in LPWRCR are valid in the U-mask and W-mask versions, and H8S/2635 Group. In versions other than the U-mask and W-mask versions, and H8S/2635 Group, however, these bits must always be written with 0 since no subclock functions are available.
 4. An I²C bus interface can only be added to the H8S/2638, H8S/2639, and H8S/2630. Therefore, IIC related registers are valid only in the H8S/2638, H8S/2639, and H8S/2630.
 5. This bit is reserved in the H8S/2636.
 6. This bit is reserved in the H8S/2636 and H8S/2635.
 7. These bits are not available in the H8S/2635 and H8S/2634.
 8. These bits are reserved in the H8S/2636, H8S/2638, H8S/2639, and H8S/2635. These bits are valid in the H8S/2630 only.

B.2 Functions

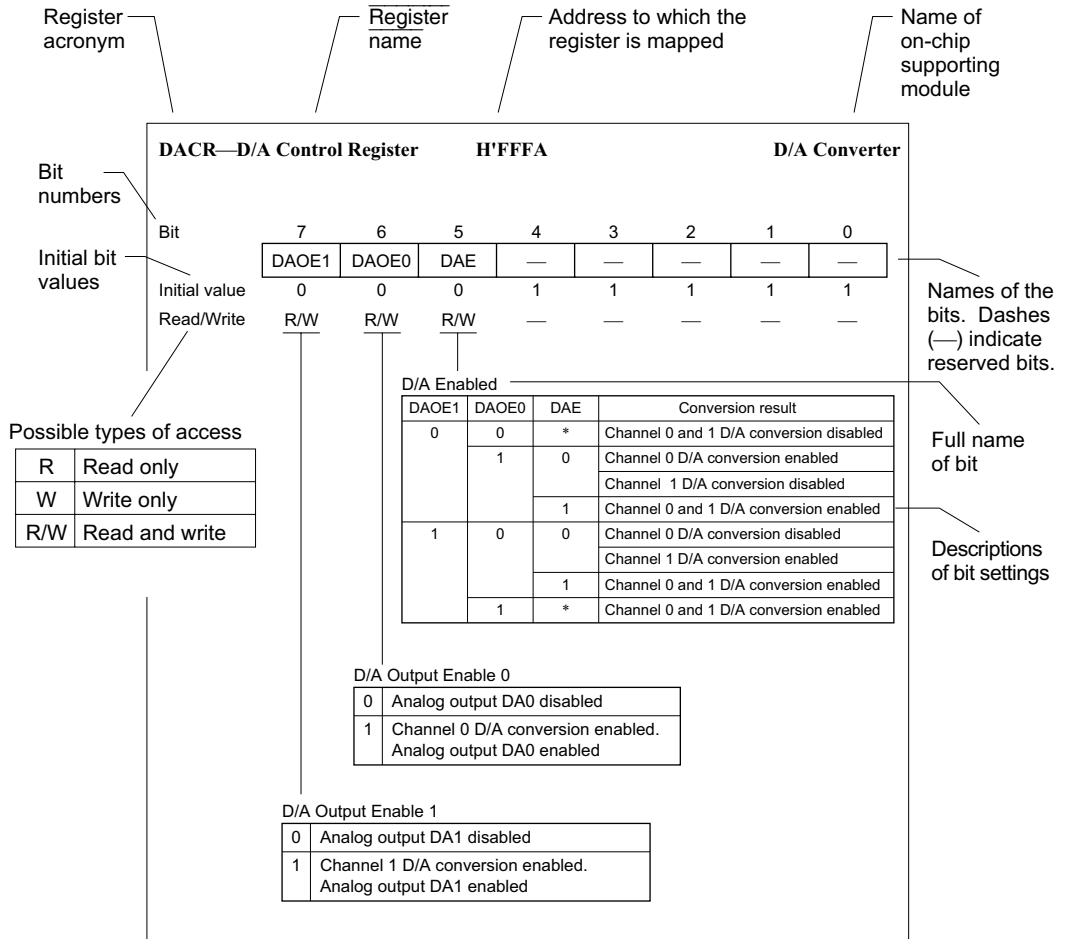

MRA—DTC Mode Register A

H'EBC0 to H'EFBF

DTC*

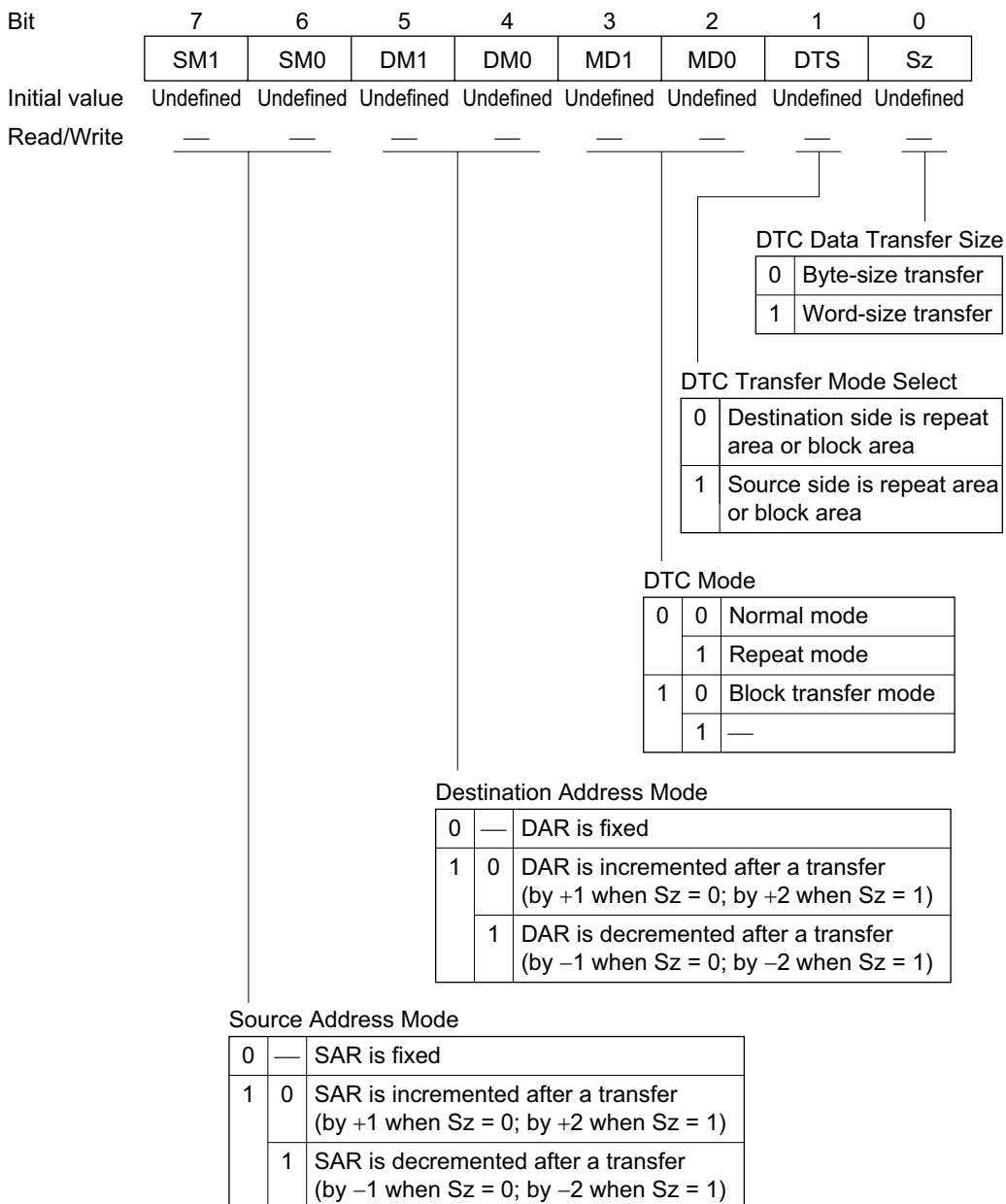

Note: * This register is not available in the H8S/2635 and H8S/2634.

MRB—DTC Mode Register B**H'EBC0 to H'EFBF****DTC***

Bit	7	6	5	4	3	2	1	0
	CHNE	DISEL	—	—	—	—	—	—
Initial value	Undefined	Undefined	Undefined	Undefined	Undefined	Undefined	Undefined	Undefined
Read/Write	—	—	—	—	—	—	—	—

DTC Interrupt Select	
0	After a data transfer ends, the CPU interrupt is disabled unless the transfer counter is 0
1	After a data transfer ends, the CPU interrupt is enabled

DTC Chain Transfer Enable	
0	End of DTC data transfer
1	DTC chain transfer

Note: * This register is not available in the H8S/2635 and H8S/2634.

SAR—DTC Source Address Register**H'EBC0 to H'EFBF****DTC***

Bit	23	22	21	20	19	---	4	3	2	1	0

Initial value	Unde- fined	Unde- fined	Unde- fined	Unde- fined	Unde- fined	---	Unde- fined	Unde- fined	Unde- fined	Unde- fined	Unde- fined
Read/Write	—	—	—	—	—	---	—	—	—	—	—

Specify DTC transfer data source address

Note: * This register is not available in the H8S/2635 and H8S/2634.

DAR—DTC Destination Address Register**H'EBC0 to H'EFBF****DTC***

Bit	23	22	21	20	19	---	4	3	2	1	0

Initial value	Unde- fined	Unde- fined	Unde- fined	Unde- fined	Unde- fined	---	Unde- fined	Unde- fined	Unde- fined	Unde- fined	Unde- fined
Read/Write	—	—	—	—	—	---	—	—	—	—	—

Specify DTC transfer data destination address

Note: * This register is not available in the H8S/2635 and H8S/2634.

CRA—DTC Transfer Count Register A **H'EBC0 to H'EFBF** **DTC***

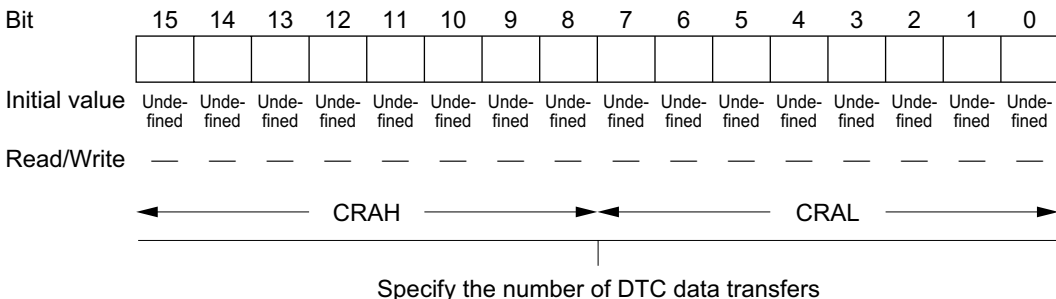

Note: * This register is not available in the H8S/2635 and H8S/2634.

CRB—DTC Transfer Count Register B **H'EBC0 to H'EFBF** **DTC***

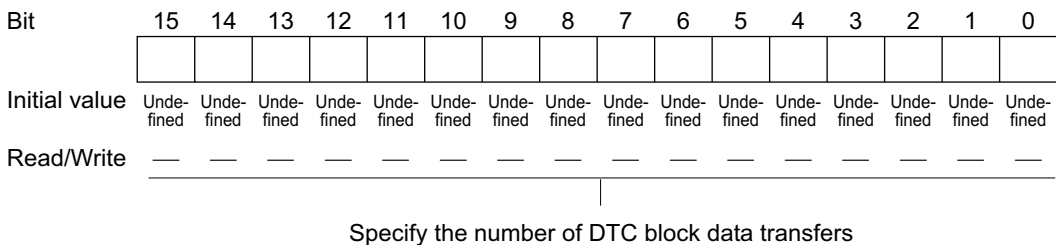

Note: * This register is not available in the H8S/2635 and H8S/2634.

MCR0—Master Control Register

MCR1—Master Control Register

H'F800

H'FA00

HCAN0

HCAN1*

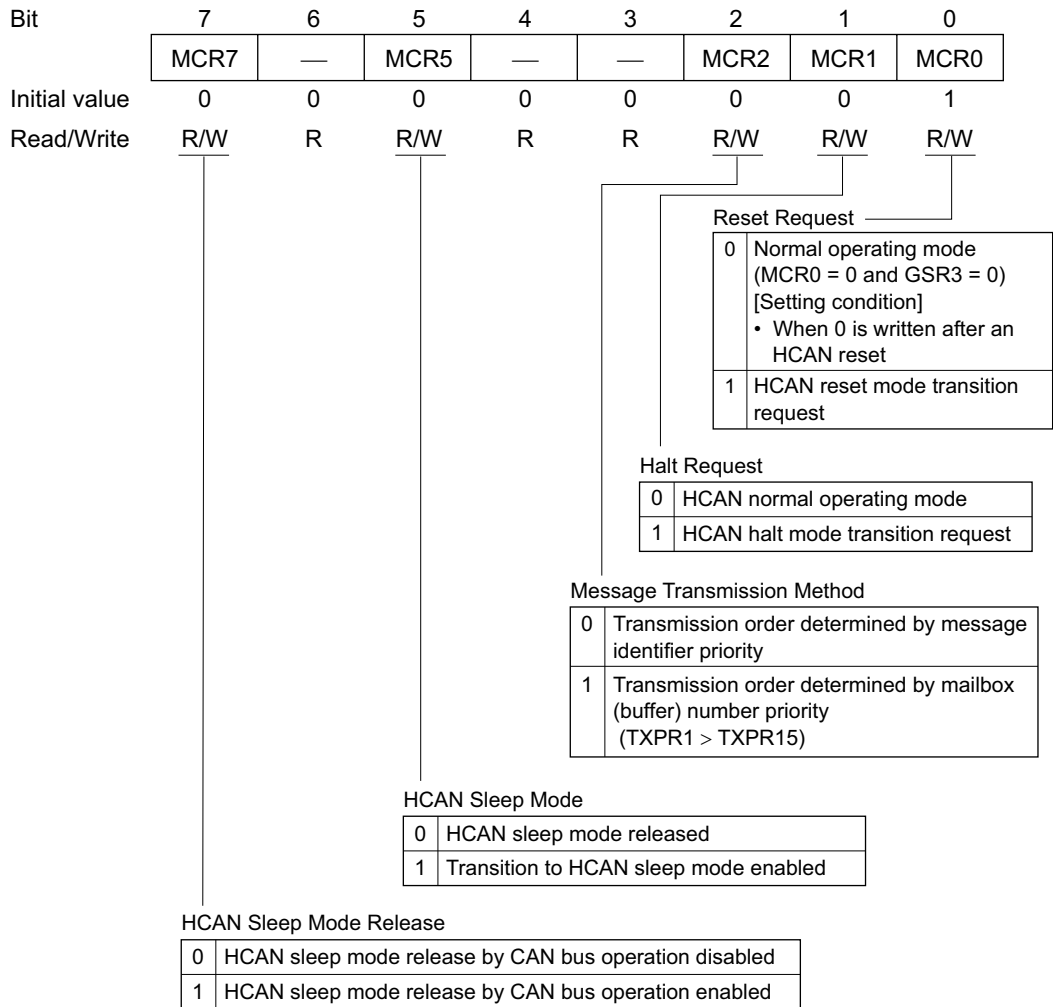

Note: * This register is not available in the H8S/2635 and H8S/2634.

GSR0—General Status Register

H'F801

HCAN0

GSR1—General Status Register

H'FA01

HCAN1*

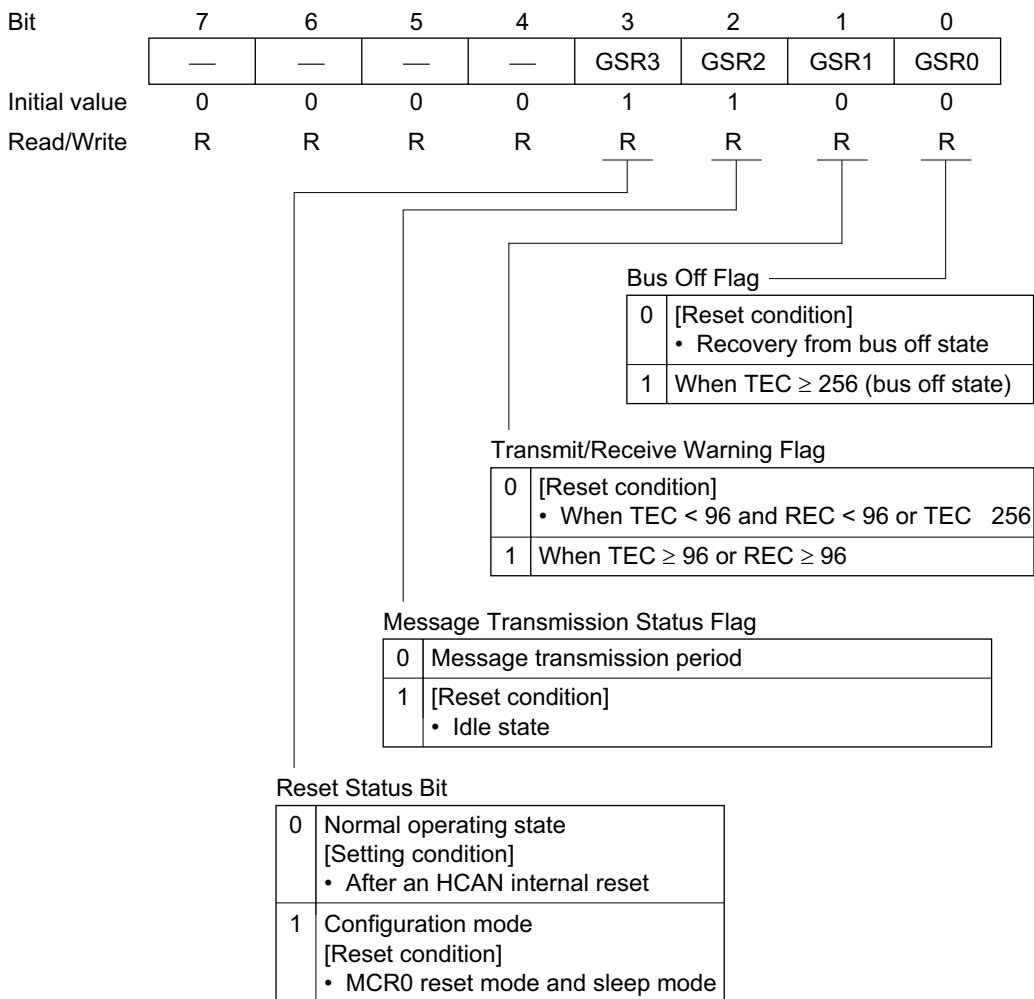

Note: * This register is not available in the H8S/2635 and H8S/2634.

BCR0—Bit Configuration Register**BCR1—Bit Configuration Register****H'F802****H'FA02****HCAN0****HCAN1***

Bit	15	14	13	12	11	10	9	8
	BCR7	BCR6	BCR5	BCR4	BCR3	BCR2	BCR1	BCR0
Initial value	0	0	0	0	0	0	0	0
Read/Write	R/W	R/W	R/W	R/W	R/W	R/W	R/W	R/W

Resynchronization Jump Width

0	0	Bit synchronization width = 1 time quantum
	1	Bit synchronization width = 2 time quanta
1	0	Bit synchronization width = 3 time quanta
	1	Bit synchronization width = 4 time quanta

Baud Rate Prescaler

0	0	0	0	0	0	2 × system clock
0	0	0	0	0	1	4 × system clock
0	0	0	0	1	0	6 × system clock
:	:	:	:	:	:	:
1	1	1	1	1	1	128 × system clock

Bit	7	6	5	4	3	2	1	0
	BCR15	BCR14	BCR13	BCR12	BCR11	BCR10	BCR9	BCR8
Initial value	0	0	0	0	0	0	0	0
Read/Write	R/W	R/W	R/W	R/W	R/W	R/W	R/W	R/W

Time Segment 2

0	0	0	Setting prohibited
		1	TSEG2 = 2 time quanta
	1	0	TSEG2 = 3 time quanta
		1	TSEG2 = 4 time quanta
1	0	0	TSEG2 = 5 time quanta
		1	TSEG2 = 6 time quanta
	1	0	TSEG2 = 7 time quanta
		1	TSEG2 = 8 time quanta

Time Segment 1

0	0	0	0	Setting prohibited
0	0	0	1	Setting prohibited
0	0	1	0	Setting prohibited
0	0	1	1	TSEG1 = 4 time quanta
0	1	0	0	TSEG1 = 5 time quanta
:	:	:	:	:
1	1	1	1	TSEG1 = 16 time quanta

Bit Sample Point

0	Bit sampling at one point (end of time segment 1 (TSEG1))
1	Bit sampling at three points (end of time segment 1 (TSEG1) and preceding and following time quanta)

Note: * This register is not available in the H8S/2635 and H8S/2634.

MBCR0—Mailbox Configuration Register**H'F804****HCAN0****MBCR1—Mailbox Configuration Register****H'FA04****HCAN1***

Bit	15	14	13	12	11	10	9	8
	MBCR7	MBCR6	MBCR5	MBCR4	MBCR3	MBCR2	MBCR1	—
Initial value	0	0	0	0	0	0	0	1
Read/Write	R/W	R/W	R/W	R/W	R/W	R/W	R/W	R

Bit	7	6	5	4	3	2	1	0
	MBCR15	MBCR14	MBCR13	MBCR12	MBCR11	MBCR10	MBCR9	MBCR8
Initial value	0	0	0	0	0	0	0	0
Read/Write	R/W	R/W	R/W	R/W	R/W	R/W	R/W	R/W

Mailbox Setting Register

0	Corresponding mailbox is set for transmission
1	Corresponding mailbox is set for reception

Note: * This register is not available in the H8S/2635 and H8S/2634.

TXPR0—Transmit Wait Register**H'F806****HCAN0****TXPR1—Transmit Wait Register****H'FA06****HCAN1***

Bit	15	14	13	12	11	10	9	8
	TXPR7	TXPR6	TXPR5	TXPR4	TXPR3	TXPR2	TXPR1	—
Initial value	0	0	0	0	0	0	0	0
Read/Write	R/W	R/W	R/W	R/W	R/W	R/W	R/W	R

Bit	7	6	5	4	3	2	1	0
	TXPR15	TXPR14	TXPR13	TXPR12	TXPR11	TXPR10	TXPR9	TXPR8
Initial value	0	0	0	0	0	0	0	0
Read/Write	R/W	R/W	R/W	R/W	R/W	R/W	R/W	R/W

Transmit Wait Register

0	Transmit message idle state in corresponding mailbox [Clearing condition] • Message transmission completion and cancellation completion
1	Transmit message transmit wait in corresponding mailbox (CAN bus arbitration)

Note: * This register is not available in the H8S/2635 and H8S/2634.

TXCR0—Transmit Wait Cancel Register**H'F808****HCAN0****TXCR1—Transmit Wait Cancel Register****H'FA08****HCAN1***

Bit	15	14	13	12	11	10	9	8
	TXCR7	TXCR6	TXCR5	TXCR4	TXCR3	TXCR2	TXCR1	—
Initial value	0	0	0	0	0	0	0	0
Read/Write	R/W	R/W	R/W	R/W	R/W	R/W	R/W	R
Bit	7	6	5	4	3	2	1	0
	TXCR15	TXCR14	TXCR13	TXCR12	TXCR11	TXCR10	TXCR9	TXCR8
Initial value	0	0	0	0	0	0	0	0
Read/Write	R/W	R/W	R/W	R/W	R/W	R/W	R/W	R/W

Transmit Wait Cancel Register

0	Transmit message cancellation idle state in corresponding mailbox [Clearing condition] • Completion of TXPR clearing (when transmit message is canceled normally)
1	TXPR cleared for corresponding mailbox (transmit message cancellation)

Note: * This register is not available in the H8S/2635 and H8S/2634.

TXACK0—Transmit Acknowledge Register**H'F80A****HCAN0****TXACK1—Transmit Acknowledge Register****H'FA04****HCAN1***

Bit	15	14	13	12	11	10	9	8
	TXACK7	TXACK6	TXACK5	TXACK4	TXACK3	TXACK2	TXACK1	—
Initial value	0	0	0	0	0	0	0	0
Read/Write	R/W	R/W	R/W	R/W	R/W	R/W	R/W	R
Bit	7	6	5	4	3	2	1	0
	TXACK15	TXACK14	TXACK13	TXACK12	TXACK11	TXACK10	TXACK9	TXACK8
Initial value	0	0	0	0	0	0	0	0
Read/Write	R/W	R/W	R/W	R/W	R/W	R/W	R/W	R/W

Transmit Acknowledge Register

0	[Clearing condition] • Writing 1
1	Completion of message transmission for corresponding mailbox

Note: * This register is not available in the H8S/2635 and H8S/2634.

ABACK0—Abort Acknowledge Register**H'F80C****HCAN0****ABACK1—Abort Acknowledge Register****H'FA0C****HCAN1***

Bit	15	14	13	12	11	10	9	8
	ABACK7	ABACK6	ABACK5	ABACK4	ABACK3	ABACK2	ABACK1	—
Initial value	0	0	0	0	0	0	0	0
Read/Write	R/W	R/W	R/W	R/W	R/W	R/W	R/W	R

Bit	7	6	5	4	3	2	1	0
	ABACK15	ABACK14	ABACK13	ABACK12	ABACK11	ABACK10	ABACK9	ABACK8
Initial value	0	0	0	0	0	0	0	0
Read/Write	R/W	R/W	R/W	R/W	R/W	R/W	R/W	R/W

Abort Acknowledge Register

0	[Clearing condition] • Writing 1
1	Completion of transmit message cancellation for corresponding mailbox

Note: * This register is not available in the H8S/2635 and H8S/2634.

RXPR0—Receive Complete Register**H'F80E****HCAN0****RXPR1—Receive Complete Register****H'FA0E****HCAN1***

Bit	15	14	13	12	11	10	9	8
	RXPR7	RXPR6	RXPR5	RXPR4	RXPR3	RXPR2	RXPR1	RXPR0
Initial value	0	0	0	0	0	0	0	0
Read/Write	R/W	R/W	R/W	R/W	R/W	R/W	R/W	R/W

Bit	7	6	5	4	3	2	1	0
	RXPR15	RXPR14	RXPR13	RXPR12	RXPR11	RXPR10	RXPR9	RXPR8
Initial value	0	0	0	0	0	0	0	0
Read/Write	R/W	R/W	R/W	R/W	R/W	R/W	R/W	R/W

Receive Complete Register

0	[Clearing condition] • Writing 1
1	Completion of message (data frame or remote frame) reception in corresponding mailbox

Note: * This register is not available in the H8S/2635 and H8S/2634.

RFPR0—Remote Request Register**H'F810****HCAN0****RFPR1—Remote Request Register****H'FA10****HCAN1***

Bit	15	14	13	12	11	10	9	8
	RFPR7	RFPR6	RFPR5	RFPR4	RFPR3	RFPR2	RFPR1	RFPR0
Initial value	0	0	0	0	0	0	0	0
Read/Write	R/W	R/W	R/W	R/W	R/W	R/W	R/W	R/W

Bit	7	6	5	4	3	2	1	0
	RFPR15	RFPR14	RFPR13	RFPR12	RFPR11	RFPR10	RFPR9	RFPR8
Initial value	0	0	0	0	0	0	0	0
Read/Write	R/W	R/W	R/W	R/W	R/W	R/W	R/W	R/W

Remote Request Register

0	[Clearing condition] • Writing 1
1	Completion of remote frame reception in corresponding mailbox

Note: * This register is not available in the H8S/2635 and H8S/2634.

IRR0—Interrupt Register

H'F812

HCAN0

IRR1—Interrupt Register

H'FA12

HCAN1*

Note: * This register is not available in the H8S/2635 and H8S/2634.

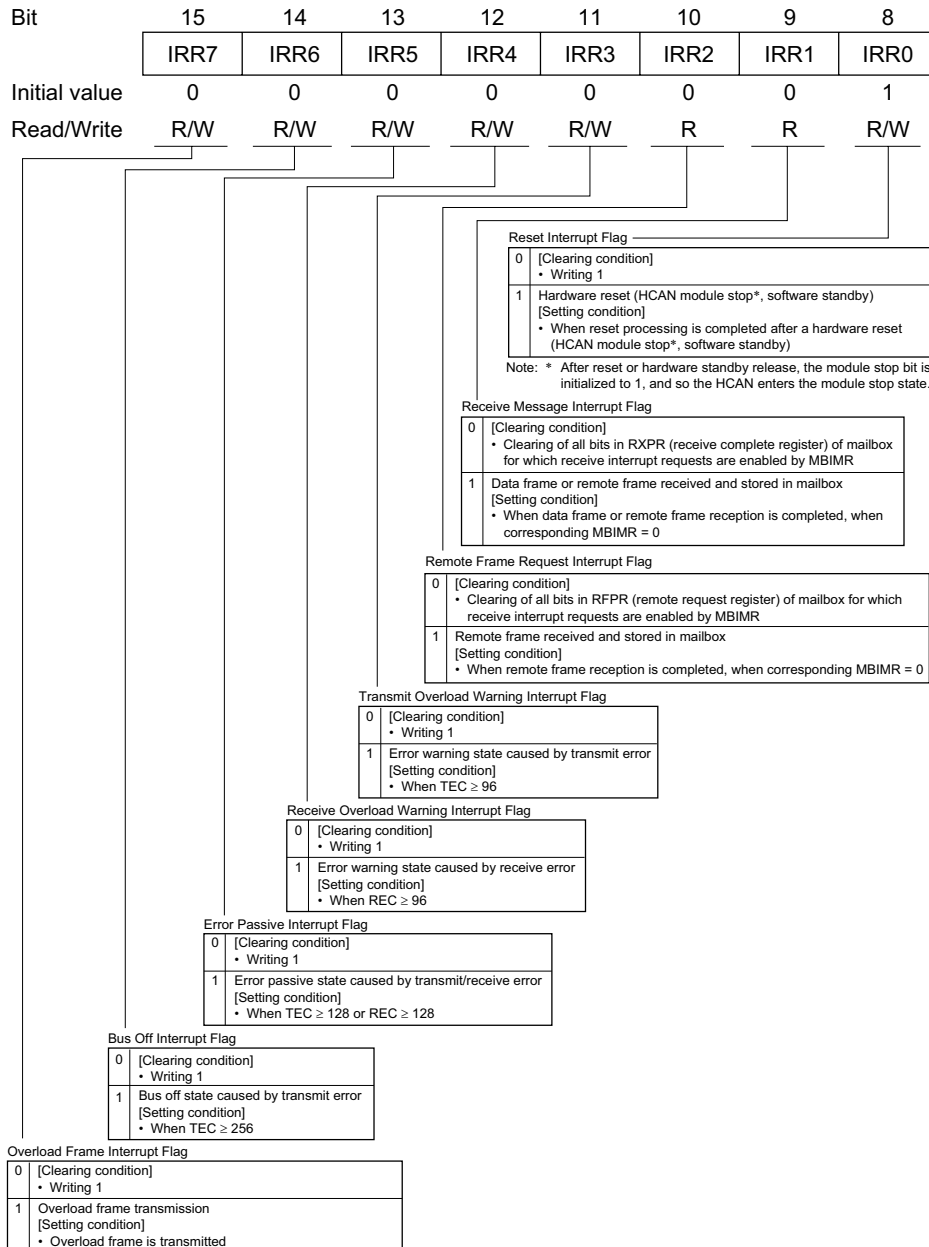

Bit	7	6	5	4	3	2	1	0
	—	—	—	IRR12	—	—	IRR9	IRR8
Initial value	0	0	0	0	0	0	0	0
Read/Write	—	—	—	R/W	—	—	R	R/W

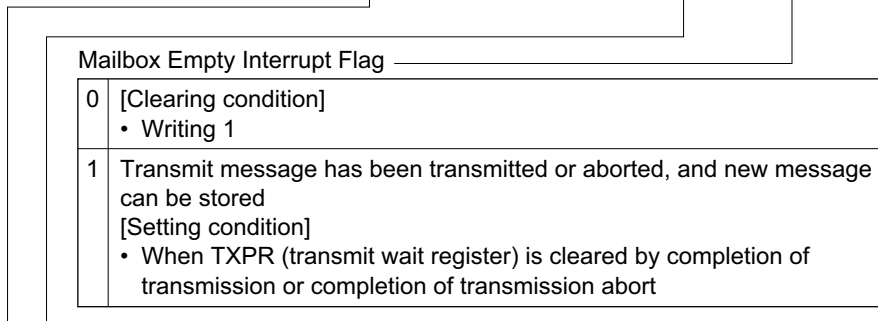

Mailbox Empty Interrupt Flag

0	[Clearing condition] • Writing 1
1	Transmit message has been transmitted or aborted, and new message can be stored [Setting condition] • When TXPR (transmit wait register) is cleared by completion of transmission or completion of transmission abort

Unread Interrupt Flag

0	[Clearing condition] • Clearing of all bits in UMSR (unread message status register)
1	Unread message overwrite [Setting condition] • When UMSR (unread message status register) is set

Bus Operation Interrupt Flag

0	CAN bus idle state [Clearing condition] • Writing 1
1	CAN bus operation in HCAN sleep mode [Setting condition] • Bus operation (dominant bit detection) in HCAN sleep mode

MBIMR0—Mailbox Interrupt Mask Register**H'F814****HCAN0****MBIMR1—Mailbox Interrupt Mask Register****H'FA14****HCAN1***

Bit	15	14	13	12	11	10	9	8
	MBIMR7	MBIMR6	MBIMR5	MBIMR4	MBIMR3	MBIMR2	MBIMR1	MBIMR0
Initial value	1	1	1	1	1	1	1	1
Read/Write	R/W	R/W	R/W	R/W	R/W	R/W	R/W	R/W

Bit	7	6	5	4	3	2	1	0
	MBIMR15	MBIMR14	MBIMR13	MBIMR12	MBIMR11	MBIMR10	MBIMR9	MBIMR8
Initial value	1	1	1	1	1	1	1	1
Read/Write	R/W	R/W	R/W	R/W	R/W	R/W	R/W	R/W

Mailbox Interrupt Mask

0	[Transmitting] • Interrupt request to CPU due to TXPR clearing [Receiving] • Interrupt request to CPU due to RXPR setting
1	Interrupt requests to CPU disabled

Note: * This register is not available in the H8S/2635 and H8S/2634.

IMR0—Interrupt Mask Register**H'F816****HCAN0****IMR1—Interrupt Mask Register****H'FA16****HCAN1***

Note: * This register is not available in the H8S/2635 and H8S/2634.

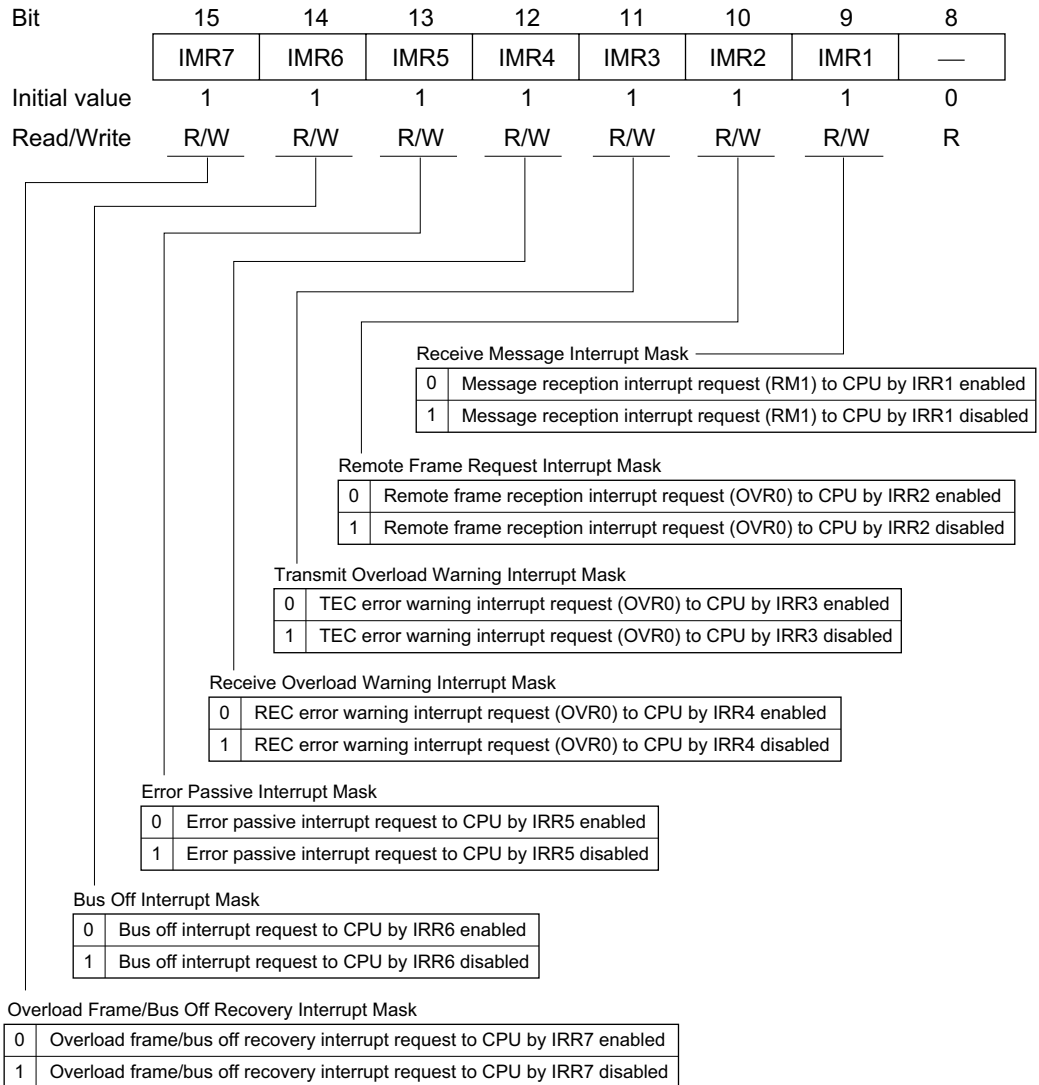

Bit	7	6	5	4	3	2	1	0
	—	—	—	IMR12	—	—	IMR9	IMR8
Initial value	1	1	1	1	1	1	1	1
Read/Write	R	R	R	R/W	R	R	R/W	R/W

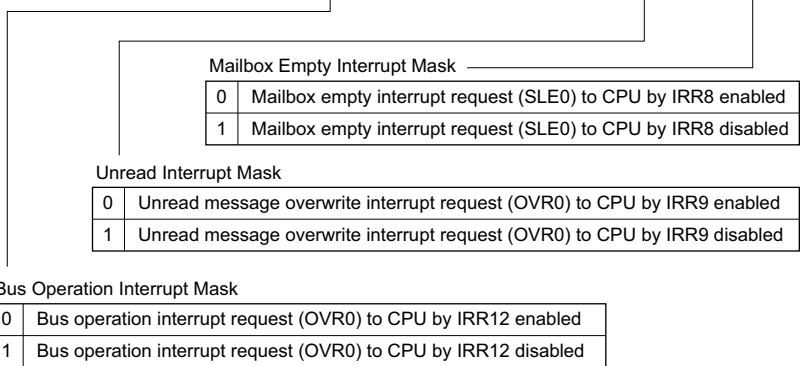

REC0—Receive Error Counter**H'F818****HCAN0****REC1—Receive Error Counter****H'FA18****HCAN1***

Bit	7	6	5	4	3	2	1	0
Initial value	0	0	0	0	0	0	0	0
Read/Write	R	R	R	R	R	R	R	R

Note: * This register is not available in the H8S/2635 and H8S/2634.

TEC0—Transmit Error Counter**H'F819****HCAN0****TEC1—Transmit Error Counter****H'FA19****HCAN1***

Bit	7	6	5	4	3	2	1	0
Initial value	0	0	0	0	0	0	0	0
Read/Write	R	R	R	R	R	R	R	R

Note: * This register is not available in the H8S/2635 and H8S/2634.

UMSR0—Unread Message Status Register**H'F81A****HCAN0****UMSR1—Unread Message Status Register****H'FA1A****HCAN1*¹**

Bit	15	14	13	12	11	10	9	8
	UMSR7	UMSR6	UMSR5	UMSR4	UMSR3	UMSR2	UMSR1	UMSR0
Initial value	0	0	0	0	0	0	0	0
Read/Write	R/(W)* ²	R/(W)* ²	R/(W)* ²	R/(W)* ²	R/(W)* ²	R/(W)* ²	R/(W)* ²	R/(W)* ²
Bit	7	6	5	4	3	2	1	0
	UMSR15	UMSR14	UMSR13	UMSR12	UMSR11	UMSR10	UMSR9	UMSR8
Initial value	0	0	0	0	0	0	0	0
Read/Write	R/(W)* ²	R/(W)* ²	R/(W)* ²	R/(W)* ²	R/(W)* ²	R/(W)* ²	R/(W)* ²	R/(W)* ²

Unread Message Status Flags

0	[Clearing condition] • Writing 1
1	Unread receive message is overwritten by a new message [Setting condition] • When a new message is received before RXPR is cleared

- Notes: 1. This register is not available in the H8S/2635 and H8S/2634.
2. Only 1 can be written, to clear the flag to 0.

LAFML0—Local Acceptance Filter Masks L	H'F81C	HCAN0
LAFMH0—Local Acceptance Filter Masks H	H'F81E	HCAN0
LAFML1—Local Acceptance Filter Masks L	H'FA1C	HCAN1*
LAFMH1—Local Acceptance Filter Masks H	H'FA1E	HCAN1*

Bit	15	14	13	12	11	10	9	8
	LAFML7	LAFML6	LAFML5	LAFML4	LAFML3	LAFML2	LAFML1	LAFML0
Initial value	0	0	0	0	0	0	0	0
Read/Write	R/W	R/W	R/W	R/W	R/W	R/W	R/W	R/W

Bit	7	6	5	4	3	2	1	0
	LAFML15	LAFML14	LAFML13	LAFML12	LAFML11	LAFML10	LAFML9	LAFML8
Initial value	0	0	0	0	0	0	0	0
Read/Write	R/W	R/W	R/W	R/W	R/W	R/W	R/W	R/W

LAFMH

Bit	15	14	13	12	11	10	9	8
	LAFMH7	LAFMH6	LAFMH5	—	—	—	LAFMH1	LAFMH0
Initial value	0	0	0	0	0	0	0	0
Read/Write	R/W	R/W	R/W	R	R	R	R/W	R/W

Bit	7	6	5	4	3	2	1	0
	LAFMH15	LAFMH14	LAFMH13	LAFMH12	LAFMH11	LAFMH10	LAFMH9	LAFMH8
Initial value	0	0	0	0	0	0	0	0
Read/Write	R/W	R/W	R/W	R/W	R/W	R/W	R/W	R/W

LAFMH Bits 7 to 0 and 15 to 13—11-Bit Identifier Filter

0	Stored in MC0 and MD0 (receive-only mailbox) depending on bit match between MC0 message identifier and receive message identifier (Care)
1	Stored in MC0 and MD0 (receive-only mailbox) regardless of bit match between MC0 message identifier and receive message identifier (Don't Care)

LAFMH Bits 9 and 8, LAFML bits 15 to 0—18-Bit Identifier Filter

0	Stored in MC0 (receive-only mailbox) depending on bit match between MC0 message identifier and receive message identifier (Care)
1	Stored in MC0 (receive-only mailbox) regardless of bit match between MC0 message identifier and receive message identifier (Don't Care)

Note: * These registers are not available in the H8S/2635 and H8S/2634.

MC0[1]—Message Control 0[1]	H'F820	HCAN0
MC0[2]—Message Control 0[2]	H'F821	HCAN0
MC0[3]—Message Control 0[3]	H'F822	HCAN0
MC0[4]—Message Control 0[4]	H'F823	HCAN0
MC0[5]—Message Control 0[5]	H'F824	HCAN0
MC0[6]—Message Control 0[6]	H'F825	HCAN0
MC0[7]—Message Control 0[7]	H'F826	HCAN0
MC0[8]—Message Control 0[8]	H'F827	HCAN0

MC0[1]

Bit	7	6	5	4	3	2	1	0
	—	—	—	—	DLC3	DLC2	DLC1	DLC0
Initial value	Undefined	Undefined	Undefined	Undefined	Undefined	Undefined	Undefined	Undefined
Read/Write	R/W	R/W	R/W	R/W	R/W	R/W	R/W	R/W

Data Length Code

0	0	0	0	Data length = 0 bytes	
		1	0	Data length = 1 byte	
		1	0	0	Data length = 2 bytes
			1	0	Data length = 3 bytes
	1	0	0	0	Data length = 4 bytes
			1	0	Data length = 5 bytes
		1	0	0	Data length = 6 bytes
			1	0	Data length = 7 bytes
1	0/1	0/1	0/1	Data length = 8 bytes	

MC0[2]

Bit	7	6	5	4	3	2	1	0
	—	—	—	—	—	—	—	—
Initial value	Undefined	Undefined	Undefined	Undefined	Undefined	Undefined	Undefined	Undefined
Read/Write	R/W	R/W	R/W	R/W	R/W	R/W	R/W	R/W

MC0[3]

Bit	7	6	5	4	3	2	1	0
	—	—	—	—	—	—	—	—
Initial value	Undefined	Undefined	Undefined	Undefined	Undefined	Undefined	Undefined	Undefined
Read/Write	R/W	R/W	R/W	R/W	R/W	R/W	R/W	R/W

MC0[4]

Bit	7	6	5	4	3	2	1	0
	—	—	—	—	—	—	—	—
Initial value	Undefined	Undefined	Undefined	Undefined	Undefined	Undefined	Undefined	Undefined
Read/Write	R/W	R/W	R/W	R/W	R/W	R/W	R/W	R/W

MC0[5]

Bit	7	6	5	4	3	2	1	0
	STD_ID2	STD_ID1	STD_ID0	RTR	IDE	—	EXD_ID17	EXD_ID16
Initial value	Undefined	Undefined	Undefined	Undefined	Undefined	Undefined	Undefined	Undefined
Read/Write	R/W	R/W	R/W	R/W	R/W	R/W	R/W	R/W

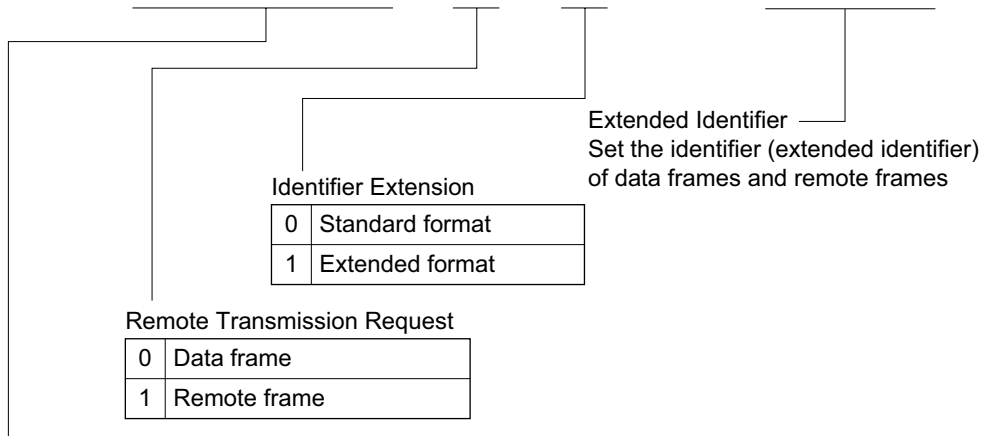

Standard Identifier

Set the identifier (standard identifier) of data frames and remote frames

MC0[6]

Bit	7	6	5	4	3	2	1	0
	STD_ID10	STD_ID9	STD_ID8	STD_ID7	STD_ID6	STD_ID5	STD_ID4	STD_ID3
Initial value	Undefined	Undefined	Undefined	Undefined	Undefined	Undefined	Undefined	Undefined
Read/Write	R/W	R/W	R/W	R/W	R/W	R/W	R/W	R/W

Standard Identifier
Set the identifier (standard identifier) of data frames and remote frames

MC0[7]

Bit	7	6	5	4	3	2	1	0
	EXD_ID7	EXD_ID6	EXD_ID5	EXD_ID4	EXD_ID3	EXD_ID2	EXD_ID1	EXD_ID0
Initial value	Undefined	Undefined	Undefined	Undefined	Undefined	Undefined	Undefined	Undefined
Read/Write	R/W	R/W	R/W	R/W	R/W	R/W	R/W	R/W

Extended Identifier

Set the identifier (extended identifier) of data frames and remote frames

MC0[8]

Bit	7	6	5	4	3	2	1	0
	EXD_ID15	EXD_ID14	EXD_ID13	EXD_ID12	EXD_ID11	EXD_ID10	EXD_ID9	EXD_ID8
Initial value	Undefined	Undefined	Undefined	Undefined	Undefined	Undefined	Undefined	Undefined
Read/Write	R/W	R/W	R/W	R/W	R/W	R/W	R/W	R/W

Extended Identifier

Set the identifier (extended identifier) of data frames and remote frames

MC1[1]—Message Control 1[1]	H'F828	HCAN0
MC1[2]—Message Control 1[2]	H'F829	HCAN0
MC1[3]—Message Control 1[3]	H'F82A	HCAN0
MC1[4]—Message Control 1[4]	H'F82B	HCAN0
MC1[5]—Message Control 1[5]	H'F82C	HCAN0
MC1[6]—Message Control 1[6]	H'F82D	HCAN0
MC1[7]—Message Control 1[7]	H'F82E	HCAN0
MC1[8]—Message Control 1[8]	H'F82F	HCAN0

MC1[1]

Bit	7	6	5	4	3	2	1	0
	—	—	—	—	DLC3	DLC2	DLC1	DLC0
Initial value	Undefined	Undefined	Undefined	Undefined	Undefined	Undefined	Undefined	Undefined
Read/Write	R/W	R/W	R/W	R/W	R/W	R/W	R/W	R/W

Data Length Code

0	0	0	0	Data length = 0 bytes
		1		Data length = 1 byte
1	0	0	0	Data length = 2 bytes
		1		Data length = 3 bytes
1	1	0	0	Data length = 4 bytes
		1		Data length = 5 bytes
1	0/1	0	0/1	Data length = 6 bytes
		1	0/1	Data length = 7 bytes
1	0/1	0/1	0/1	Data length = 8 bytes

MC1[2]

Bit	7	6	5	4	3	2	1	0
	—	—	—	—	—	—	—	—
Initial value	Undefined	Undefined	Undefined	Undefined	Undefined	Undefined	Undefined	Undefined
Read/Write	R/W	R/W	R/W	R/W	R/W	R/W	R/W	R/W

MC1[3]

Bit	7	6	5	4	3	2	1	0
	—	—	—	—	—	—	—	—
Initial value	Undefined	Undefined	Undefined	Undefined	Undefined	Undefined	Undefined	Undefined
Read/Write	R/W	R/W	R/W	R/W	R/W	R/W	R/W	R/W

MC1[4]

Bit	7	6	5	4	3	2	1	0
	—	—	—	—	—	—	—	—
Initial value	Undefined	Undefined	Undefined	Undefined	Undefined	Undefined	Undefined	Undefined
Read/Write	R/W	R/W	R/W	R/W	R/W	R/W	R/W	R/W

MC1[5]

Bit	7	6	5	4	3	2	1	0
	STD_ID2	STD_ID1	STD_ID0	RTR	IDE	—	EXD_ID17	EXD_ID16
Initial value	Undefined	Undefined	Undefined	Undefined	Undefined	Undefined	Undefined	Undefined
Read/Write	R/W	R/W	R/W	R/W	R/W	R/W	R/W	R/W

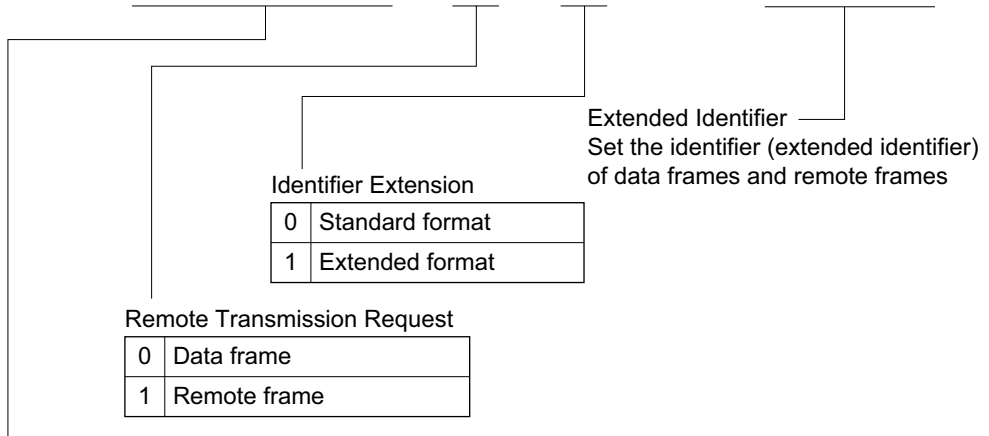

Identifier Extension

0	Standard format
1	Extended format

Remote Transmission Request

0	Data frame
1	Remote frame

Standard Identifier

Set the identifier (standard identifier) of data frames and remote frames

MC1[6]

Bit	7	6	5	4	3	2	1	0
	STD_ID10	STD_ID9	STD_ID8	STD_ID7	STD_ID6	STD_ID5	STD_ID4	STD_ID3
Initial value	Undefined	Undefined	Undefined	Undefined	Undefined	Undefined	Undefined	Undefined
Read/Write	R/W	R/W	R/W	R/W	R/W	R/W	R/W	R/W

Standard Identifier _____
 Set the identifier (standard identifier) of data frames and remote frames

MC1[7]

Bit	7	6	5	4	3	2	1	0
	EXD_ID7	EXD_ID6	EXD_ID5	EXD_ID4	EXD_ID3	EXD_ID2	EXD_ID1	EXD_ID0
Initial value	Undefined	Undefined	Undefined	Undefined	Undefined	Undefined	Undefined	Undefined
Read/Write	R/W	R/W	R/W	R/W	R/W	R/W	R/W	R/W

Extended Identifier _____

Set the identifier (extended identifier) of data frames and remote frames

MC1[8]

Bit	7	6	5	4	3	2	1	0
	EXD_ID15	EXD_ID14	EXD_ID13	EXD_ID12	EXD_ID11	EXD_ID10	EXD_ID9	EXD_ID8
Initial value	Undefined	Undefined	Undefined	Undefined	Undefined	Undefined	Undefined	Undefined
Read/Write	R/W	R/W	R/W	R/W	R/W	R/W	R/W	R/W

Extended Identifier _____

Set the identifier (extended identifier) of data frames and remote frames

MC2[1]—Message Control 2[1]	H'F830	HCAN0
MC2[2]—Message Control 2[2]	H'F831	HCAN0
MC2[3]—Message Control 2[3]	H'F832	HCAN0
MC2[4]—Message Control 2[4]	H'F833	HCAN0
MC2[5]—Message Control 2[5]	H'F834	HCAN0
MC2[6]—Message Control 2[6]	H'F835	HCAN0
MC2[7]—Message Control 2[7]	H'F836	HCAN0
MC2[8]—Message Control 2[8]	H'F837	HCAN0

MC2[1]

Bit	7	6	5	4	3	2	1	0
	—	—	—	—	DLC3	DLC2	DLC1	DLC0
Initial value	Undefined	Undefined	Undefined	Undefined	Undefined	Undefined	Undefined	Undefined
Read/Write	R/W	R/W	R/W	R/W	R/W	R/W	R/W	R/W

Data Length Code

0	0	0	0	Data length = 0 bytes
		1		Data length = 1 byte
		1	0	Data length = 2 bytes
			1	Data length = 3 bytes
	1	0	0	Data length = 4 bytes
			1	Data length = 5 bytes
		1	0	Data length = 6 bytes
			1	Data length = 7 bytes
1	0/1	0/1	0/1	Data length = 8 bytes

MC2[2]

Bit	7	6	5	4	3	2	1	0
	—	—	—	—	—	—	—	—
Initial value	Undefined	Undefined	Undefined	Undefined	Undefined	Undefined	Undefined	Undefined
Read/Write	R/W	R/W	R/W	R/W	R/W	R/W	R/W	R/W

MC2[3]

Bit	7	6	5	4	3	2	1	0
	—	—	—	—	—	—	—	—
Initial value	Undefined	Undefined	Undefined	Undefined	Undefined	Undefined	Undefined	Undefined
Read/Write	R/W	R/W	R/W	R/W	R/W	R/W	R/W	R/W

MC2[4]

Bit	7	6	5	4	3	2	1	0
	—	—	—	—	—	—	—	—
Initial value	Undefined	Undefined	Undefined	Undefined	Undefined	Undefined	Undefined	Undefined
Read/Write	R/W	R/W	R/W	R/W	R/W	R/W	R/W	R/W

MC2[5]

Bit	7	6	5	4	3	2	1	0
	STD_ID2	STD_ID1	STD_ID0	RTR	IDE	—	EXD_ID17	EXD_ID16
Initial value	Undefined	Undefined	Undefined	Undefined	Undefined	Undefined	Undefined	Undefined
Read/Write	R/W	R/W	R/W	R/W	R/W	R/W	R/W	R/W

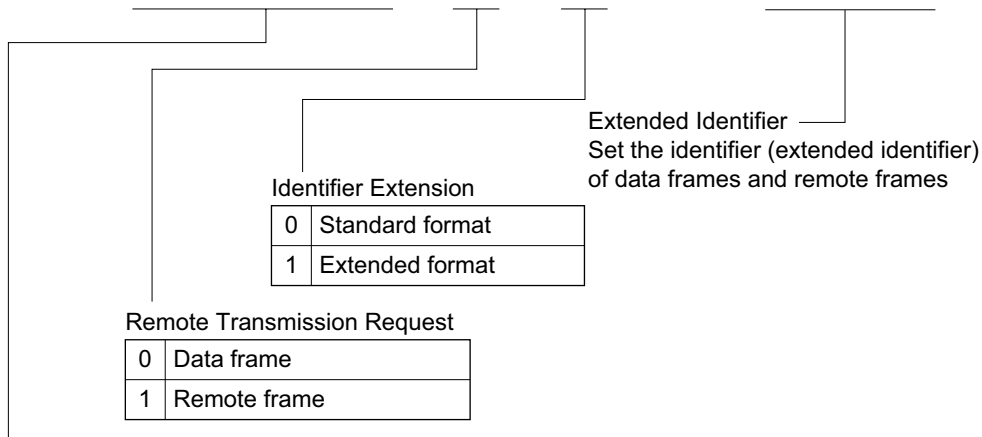

Identifier Extension

0	Standard format
1	Extended format

Remote Transmission Request

0	Data frame
1	Remote frame

Extended Identifier
Set the identifier (extended identifier) of data frames and remote frames

Standard Identifier

Set the identifier (standard identifier) of data frames and remote frames

MC2[6]

Bit	7	6	5	4	3	2	1	0
	STD_ID10	STD_ID9	STD_ID8	STD_ID7	STD_ID6	STD_ID5	STD_ID4	STD_ID3
Initial value	Undefined	Undefined	Undefined	Undefined	Undefined	Undefined	Undefined	Undefined
Read/Write	R/W	R/W	R/W	R/W	R/W	R/W	R/W	R/W

Standard Identifier
Set the identifier (standard identifier) of data frames and remote frames

MC2[7]

Bit	7	6	5	4	3	2	1	0
	EXD_ID7	EXD_ID6	EXD_ID5	EXD_ID4	EXD_ID3	EXD_ID2	EXD_ID1	EXD_ID0
Initial value	Undefined	Undefined	Undefined	Undefined	Undefined	Undefined	Undefined	Undefined
Read/Write	R/W	R/W	R/W	R/W	R/W	R/W	R/W	R/W

Extended Identifier

Set the identifier (extended identifier) of data frames and remote frames

MC2[8]

Bit	7	6	5	4	3	2	1	0
	EXD_ID15	EXD_ID14	EXD_ID13	EXD_ID12	EXD_ID11	EXD_ID10	EXD_ID9	EXD_ID8
Initial value	Undefined	Undefined	Undefined	Undefined	Undefined	Undefined	Undefined	Undefined
Read/Write	R/W	R/W	R/W	R/W	R/W	R/W	R/W	R/W

Extended Identifier

Set the identifier (extended identifier) of data frames and remote frames

MC3[1]—Message Control 3[1]	H'F838	HCAN0
MC3[2]—Message Control 3[2]	H'F839	HCAN0
MC3[3]—Message Control 3[3]	H'F83A	HCAN0
MC3[4]—Message Control 3[4]	H'F83B	HCAN0
MC3[5]—Message Control 3[5]	H'F83C	HCAN0
MC3[6]—Message Control 3[6]	H'F83D	HCAN0
MC3[7]—Message Control 3[7]	H'F83E	HCAN0
MC3[8]—Message Control 3[8]	H'F83F	HCAN0

MC3[1]

Bit	7	6	5	4	3	2	1	0
	—	—	—	—	DLC3	DLC2	DLC1	DLC0
Initial value	Undefined	Undefined	Undefined	Undefined	Undefined	Undefined	Undefined	Undefined
Read/Write	R/W	R/W	R/W	R/W	R/W	R/W	R/W	R/W

Data Length Code

0	0	0	0	Data length = 0 bytes
		1		Data length = 1 byte
		1	0	Data length = 2 bytes
			1	Data length = 3 bytes
	1	0	0	Data length = 4 bytes
			1	Data length = 5 bytes
		1	0	Data length = 6 bytes
			1	Data length = 7 bytes
1	0/1	0/1	0/1	Data length = 8 bytes

MC3[2]

Bit	7	6	5	4	3	2	1	0
	—	—	—	—	—	—	—	—
Initial value	Undefined	Undefined	Undefined	Undefined	Undefined	Undefined	Undefined	Undefined
Read/Write	R/W	R/W	R/W	R/W	R/W	R/W	R/W	R/W

MC3[3]

Bit	7	6	5	4	3	2	1	0
	—	—	—	—	—	—	—	—
Initial value	Undefined	Undefined	Undefined	Undefined	Undefined	Undefined	Undefined	Undefined
Read/Write	R/W	R/W	R/W	R/W	R/W	R/W	R/W	R/W

MC3[4]

Bit	7	6	5	4	3	2	1	0
	—	—	—	—	—	—	—	—
Initial value	Undefined	Undefined	Undefined	Undefined	Undefined	Undefined	Undefined	Undefined
Read/Write	R/W	R/W	R/W	R/W	R/W	R/W	R/W	R/W

MC3[5]

Bit	7	6	5	4	3	2	1	0
	STD_ID2	STD_ID1	STD_ID0	RTR	IDE	—	EXD_ID17	EXD_ID16
Initial value	Undefined	Undefined	Undefined	Undefined	Undefined	Undefined	Undefined	Undefined
Read/Write	R/W	R/W	R/W	R/W	R/W	R/W	R/W	R/W

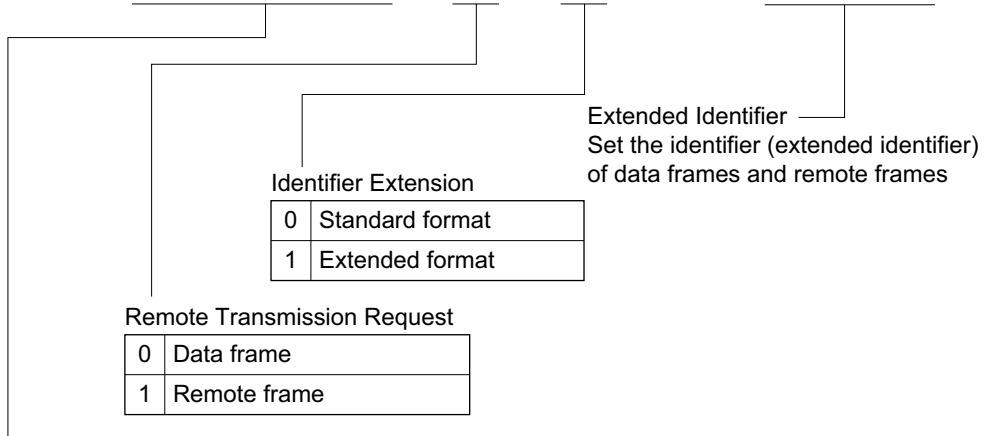

Standard Identifier

Set the identifier (standard identifier) of data frames and remote frames

MC3[6]

Bit	7	6	5	4	3	2	1	0
	STD_ID10	STD_ID9	STD_ID8	STD_ID7	STD_ID6	STD_ID5	STD_ID4	STD_ID3
Initial value	Undefined	Undefined	Undefined	Undefined	Undefined	Undefined	Undefined	Undefined
Read/Write	R/W	R/W	R/W	R/W	R/W	R/W	R/W	R/W

Standard Identifier
Set the identifier (standard identifier) of data frames and remote frames

MC3[7]

Bit	7	6	5	4	3	2	1	0
	EXD_ID7	EXD_ID6	EXD_ID5	EXD_ID4	EXD_ID3	EXD_ID2	EXD_ID1	EXD_ID0
Initial value	Undefined	Undefined	Undefined	Undefined	Undefined	Undefined	Undefined	Undefined
Read/Write	R/W	R/W	R/W	R/W	R/W	R/W	R/W	R/W

Extended Identifier _____

Set the identifier (extended identifier) of data frames and remote frames

MC3[8]

Bit	7	6	5	4	3	2	1	0
	EXD_ID15	EXD_ID14	EXD_ID13	EXD_ID12	EXD_ID11	EXD_ID10	EXD_ID9	EXD_ID8
Initial value	Undefined	Undefined	Undefined	Undefined	Undefined	Undefined	Undefined	Undefined
Read/Write	R/W	R/W	R/W	R/W	R/W	R/W	R/W	R/W

Extended Identifier _____

Set the identifier (extended identifier) of data frames and remote frames

MC4[1]—Message Control 4[1]	H'F840	HCAN0
MC4[2]—Message Control 4[2]	H'F841	HCAN0
MC4[3]—Message Control 4[3]	H'F842	HCAN0
MC4[4]—Message Control 4[4]	H'F843	HCAN0
MC4[5]—Message Control 4[5]	H'F844	HCAN0
MC4[6]—Message Control 4[6]	H'F845	HCAN0
MC4[7]—Message Control 4[7]	H'F846	HCAN0
MC4[8]—Message Control 4[8]	H'F847	HCAN0

MC4[1]

Bit	7	6	5	4	3	2	1	0
	—	—	—	—	DLC3	DLC2	DLC1	DLC0
Initial value	Undefined	Undefined	Undefined	Undefined	Undefined	Undefined	Undefined	Undefined
Read/Write	R/W	R/W	R/W	R/W	R/W	R/W	R/W	R/W

Data Length Code

0	0	0	0	Data length = 0 bytes
		1	Data length = 1 byte	
		1	0	Data length = 2 bytes
			1	Data length = 3 bytes
	1	0	0	Data length = 4 bytes
			1	Data length = 5 bytes
		1	0	Data length = 6 bytes
			1	Data length = 7 bytes
1	0/1	0/1	0/1	Data length = 8 bytes

MC4[2]

Bit	7	6	5	4	3	2	1	0
	—	—	—	—	—	—	—	—
Initial value	Undefined	Undefined	Undefined	Undefined	Undefined	Undefined	Undefined	Undefined
Read/Write	R/W	R/W	R/W	R/W	R/W	R/W	R/W	R/W

MC4[3]

Bit	7	6	5	4	3	2	1	0
	—	—	—	—	—	—	—	—
Initial value	Undefined	Undefined	Undefined	Undefined	Undefined	Undefined	Undefined	Undefined
Read/Write	R/W	R/W	R/W	R/W	R/W	R/W	R/W	R/W

MC4[4]

Bit	7	6	5	4	3	2	1	0
	—	—	—	—	—	—	—	—
Initial value	Undefined	Undefined	Undefined	Undefined	Undefined	Undefined	Undefined	Undefined
Read/Write	R/W	R/W	R/W	R/W	R/W	R/W	R/W	R/W

MC4[5]

Bit	7	6	5	4	3	2	1	0
	STD_ID2	STD_ID1	STD_ID0	RTR	IDE	—	EXD_ID17	EXD_ID16
Initial value	Undefined	Undefined	Undefined	Undefined	Undefined	Undefined	Undefined	Undefined
Read/Write	R/W	R/W	R/W	R/W	R/W	R/W	R/W	R/W

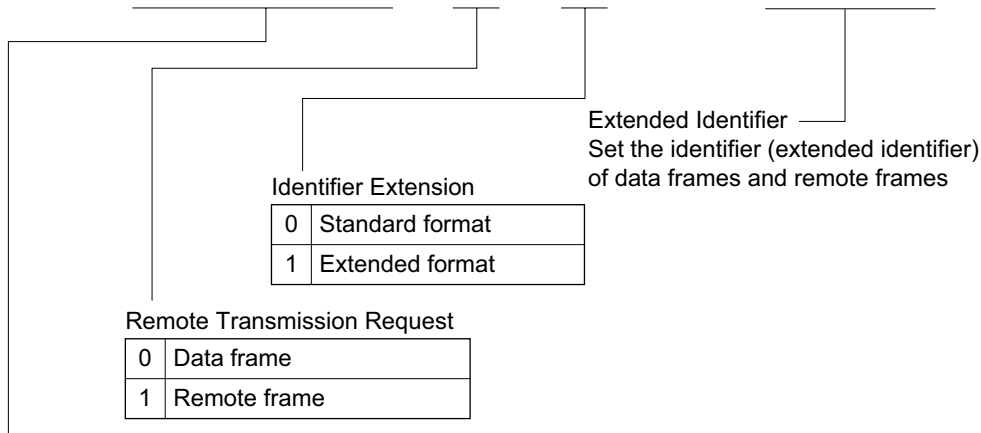

Identifier Extension

0	Standard format
1	Extended format

Remote Transmission Request

0	Data frame
1	Remote frame

Extended Identifier
Set the identifier (extended identifier) of data frames and remote frames

Standard Identifier

Set the identifier (standard identifier) of data frames and remote frames

MC4[6]

Bit	7	6	5	4	3	2	1	0
	STD_ID10	STD_ID9	STD_ID8	STD_ID7	STD_ID6	STD_ID5	STD_ID4	STD_ID3
Initial value	Undefined	Undefined	Undefined	Undefined	Undefined	Undefined	Undefined	Undefined
Read/Write	R/W	R/W	R/W	R/W	R/W	R/W	R/W	R/W

Standard Identifier
Set the identifier (standard identifier) of data frames and remote frames

MC4[7]

Bit	7	6	5	4	3	2	1	0
	EXD_ID7	EXD_ID6	EXD_ID5	EXD_ID4	EXD_ID3	EXD_ID2	EXD_ID1	EXD_ID0
Initial value	Undefined	Undefined	Undefined	Undefined	Undefined	Undefined	Undefined	Undefined
Read/Write	R/W	R/W	R/W	R/W	R/W	R/W	R/W	R/W

Extended Identifier

Set the identifier (extended identifier) of data frames and remote frames

MC4[8]

Bit	7	6	5	4	3	2	1	0
	EXD_ID15	EXD_ID14	EXD_ID13	EXD_ID12	EXD_ID11	EXD_ID10	EXD_ID9	EXD_ID8
Initial value	Undefined	Undefined	Undefined	Undefined	Undefined	Undefined	Undefined	Undefined
Read/Write	R/W	R/W	R/W	R/W	R/W	R/W	R/W	R/W

Extended Identifier

Set the identifier (extended identifier) of data frames and remote frames

MC5[1]—Message Control 5[1]	H'F848	HCAN0
MC5[2]—Message Control 5[2]	H'F849	HCAN0
MC5[3]—Message Control 5[3]	H'F84A	HCAN0
MC5[4]—Message Control 5[4]	H'F84B	HCAN0
MC5[5]—Message Control 5[5]	H'F84C	HCAN0
MC5[6]—Message Control 5[6]	H'F84D	HCAN0
MC5[7]—Message Control 5[7]	H'F84E	HCAN0
MC5[8]—Message Control 5[8]	H'F84F	HCAN0

MC5[1]

Bit	7	6	5	4	3	2	1	0
	—	—	—	—	DLC3	DLC2	DLC1	DLC0
Initial value	Undefined	Undefined	Undefined	Undefined	Undefined	Undefined	Undefined	Undefined
Read/Write	R/W	R/W	R/W	R/W	R/W	R/W	R/W	R/W

Data Length Code

0	0	0	0	Data length = 0 bytes
		1		Data length = 1 byte
1	0	0	0	Data length = 2 bytes
		1		Data length = 3 bytes
1	0	0	0	Data length = 4 bytes
		1		Data length = 5 bytes
	1	0	0	Data length = 6 bytes
		1		Data length = 7 bytes
1	0/1	0/1	0/1	Data length = 8 bytes

MC5[2]

Bit	7	6	5	4	3	2	1	0
	—	—	—	—	—	—	—	—
Initial value	Undefined	Undefined	Undefined	Undefined	Undefined	Undefined	Undefined	Undefined
Read/Write	R/W	R/W	R/W	R/W	R/W	R/W	R/W	R/W

MC5[3]

Bit	7	6	5	4	3	2	1	0
	—	—	—	—	—	—	—	—
Initial value	Undefined	Undefined	Undefined	Undefined	Undefined	Undefined	Undefined	Undefined
Read/Write	R/W	R/W	R/W	R/W	R/W	R/W	R/W	R/W

MC5[4]

Bit	7	6	5	4	3	2	1	0
	—	—	—	—	—	—	—	—
Initial value	Undefined	Undefined	Undefined	Undefined	Undefined	Undefined	Undefined	Undefined
Read/Write	R/W	R/W	R/W	R/W	R/W	R/W	R/W	R/W

MC5[5]

Bit	7	6	5	4	3	2	1	0
	STD_ID2	STD_ID1	STD_ID0	RTR	IDE	—	EXD_ID17	EXD_ID16
Initial value	Undefined	Undefined	Undefined	Undefined	Undefined	Undefined	Undefined	Undefined
Read/Write	R/W	R/W	R/W	R/W	R/W	R/W	R/W	R/W

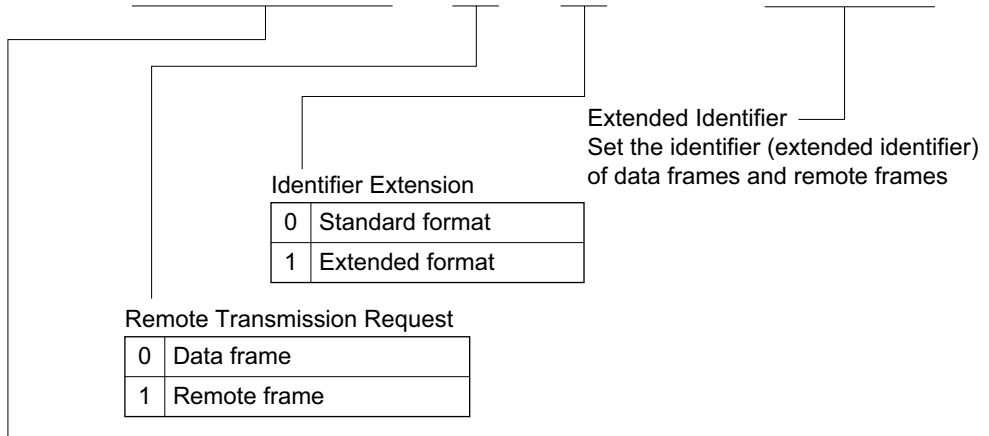

Identifier Extension

0	Standard format
1	Extended format

Remote Transmission Request

0	Data frame
1	Remote frame

Standard Identifier

Set the identifier (standard identifier) of data frames and remote frames

MC5[6]

Bit	7	6	5	4	3	2	1	0
	STD_ID10	STD_ID9	STD_ID8	STD_ID7	STD_ID6	STD_ID5	STD_ID4	STD_ID3
Initial value	Undefined	Undefined	Undefined	Undefined	Undefined	Undefined	Undefined	Undefined
Read/Write	R/W	R/W	R/W	R/W	R/W	R/W	R/W	R/W

Standard Identifier _____
 Set the identifier (standard identifier) of data frames and remote frames

MC5[7]

Bit	7	6	5	4	3	2	1	0
	EXD_ID7	EXD_ID6	EXD_ID5	EXD_ID4	EXD_ID3	EXD_ID2	EXD_ID1	EXD_ID0
Initial value	Undefined	Undefined	Undefined	Undefined	Undefined	Undefined	Undefined	Undefined
Read/Write	R/W	R/W	R/W	R/W	R/W	R/W	R/W	R/W

Extended Identifier _____

Set the identifier (extended identifier) of data frames and remote frames

MC5[8]

Bit	7	6	5	4	3	2	1	0
	EXD_ID15	EXD_ID14	EXD_ID13	EXD_ID12	EXD_ID11	EXD_ID10	EXD_ID9	EXD_ID8
Initial value	Undefined	Undefined	Undefined	Undefined	Undefined	Undefined	Undefined	Undefined
Read/Write	R/W	R/W	R/W	R/W	R/W	R/W	R/W	R/W

Extended Identifier _____

Set the identifier (extended identifier) of data frames and remote frames

MC6[1]—Message Control 6[1]	H'F850	HCAN0
MC6[2]—Message Control 6[2]	H'F851	HCAN0
MC6[3]—Message Control 6[3]	H'F852	HCAN0
MC6[4]—Message Control 6[4]	H'F853	HCAN0
MC6[5]—Message Control 6[5]	H'F854	HCAN0
MC6[6]—Message Control 6[6]	H'F855	HCAN0
MC6[7]—Message Control 6[7]	H'F856	HCAN0
MC6[8]—Message Control 6[8]	H'F857	HCAN0

MC6[1]

Bit	7	6	5	4	3	2	1	0
	—	—	—	—	DLC3	DLC2	DLC1	DLC0
Initial value	Undefined	Undefined	Undefined	Undefined	Undefined	Undefined	Undefined	Undefined
Read/Write	R/W	R/W	R/W	R/W	R/W	R/W	R/W	R/W

Data Length Code

0	0	0	0	Data length = 0 bytes
		1	0	Data length = 1 byte
		1	0	Data length = 2 bytes
			1	Data length = 3 bytes
	1	0	0	Data length = 4 bytes
			1	Data length = 5 bytes
		1	0	Data length = 6 bytes
			1	Data length = 7 bytes
1	0/1	0/1	0/1	Data length = 8 bytes

MC6[2]

Bit	7	6	5	4	3	2	1	0
	—	—	—	—	—	—	—	—
Initial value	Undefined	Undefined	Undefined	Undefined	Undefined	Undefined	Undefined	Undefined
Read/Write	R/W	R/W	R/W	R/W	R/W	R/W	R/W	R/W

MC6[3]

Bit	7	6	5	4	3	2	1	0
	—	—	—	—	—	—	—	—
Initial value	Undefined	Undefined	Undefined	Undefined	Undefined	Undefined	Undefined	Undefined
Read/Write	R/W	R/W	R/W	R/W	R/W	R/W	R/W	R/W

MC6[4]

Bit	7	6	5	4	3	2	1	0
	—	—	—	—	—	—	—	—
Initial value	Undefined	Undefined	Undefined	Undefined	Undefined	Undefined	Undefined	Undefined
Read/Write	R/W	R/W	R/W	R/W	R/W	R/W	R/W	R/W

MC6[5]

Bit	7	6	5	4	3	2	1	0
	STD_ID2	STD_ID1	STD_ID0	RTR	IDE	—	EXD_ID17	EXD_ID16
Initial value	Undefined	Undefined	Undefined	Undefined	Undefined	Undefined	Undefined	Undefined
Read/Write	R/W	R/W	R/W	R/W	R/W	R/W	R/W	R/W

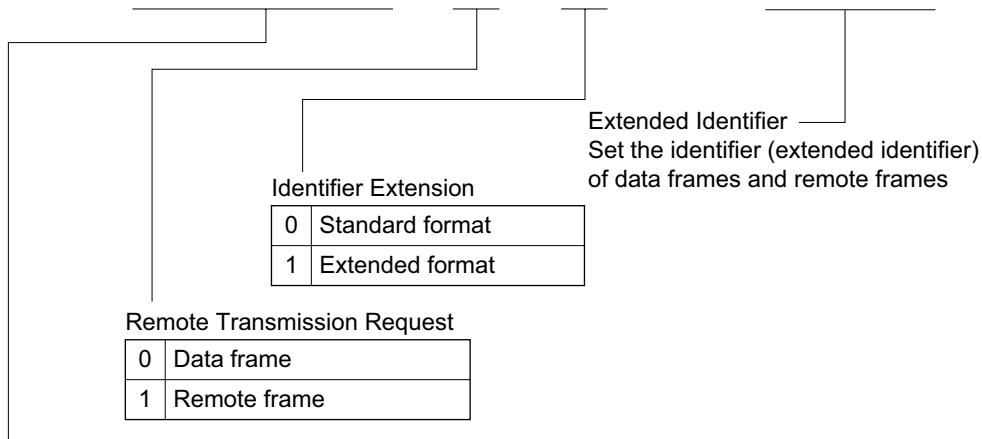

Identifier Extension

0	Standard format
1	Extended format

Remote Transmission Request

0	Data frame
1	Remote frame

Extended Identifier
Set the identifier (extended identifier) of data frames and remote frames

Standard Identifier
Set the identifier (standard identifier) of data frames and remote frames

MC6[6]

Bit	7	6	5	4	3	2	1	0
	STD_ID10	STD_ID9	STD_ID8	STD_ID7	STD_ID6	STD_ID5	STD_ID4	STD_ID3
Initial value	Undefined	Undefined	Undefined	Undefined	Undefined	Undefined	Undefined	Undefined
Read/Write	R/W	R/W	R/W	R/W	R/W	R/W	R/W	R/W

Standard Identifier
Set the identifier (standard identifier) of data frames and remote frames

MC6[7]

Bit	7	6	5	4	3	2	1	0
	EXD_ID7	EXD_ID6	EXD_ID5	EXD_ID4	EXD_ID3	EXD_ID2	EXD_ID1	EXD_ID0
Initial value	Undefined	Undefined	Undefined	Undefined	Undefined	Undefined	Undefined	Undefined
Read/Write	R/W	R/W	R/W	R/W	R/W	R/W	R/W	R/W

Extended Identifier

Set the identifier (extended identifier) of data frames and remote frames

MC6[8]

Bit	7	6	5	4	3	2	1	0
	EXD_ID15	EXD_ID14	EXD_ID13	EXD_ID12	EXD_ID11	EXD_ID10	EXD_ID9	EXD_ID8
Initial value	Undefined	Undefined	Undefined	Undefined	Undefined	Undefined	Undefined	Undefined
Read/Write	R/W	R/W	R/W	R/W	R/W	R/W	R/W	R/W

Extended Identifier

Set the identifier (extended identifier) of data frames and remote frames

MC7[1]—Message Control 7[1]	H'F858	HCAN0
MC7[2]—Message Control 7[2]	H'F859	HCAN0
MC7[3]—Message Control 7[3]	H'F85A	HCAN0
MC7[4]—Message Control 7[4]	H'F85B	HCAN0
MC7[5]—Message Control 7[5]	H'F85C	HCAN0
MC7[6]—Message Control 7[6]	H'F85D	HCAN0
MC7[7]—Message Control 7[7]	H'F85E	HCAN0
MC7[8]—Message Control 7[8]	H'F85F	HCAN0

MC7[1]

Bit	7	6	5	4	3	2	1	0
	—	—	—	—	DLC3	DLC2	DLC1	DLC0
Initial value	Undefined	Undefined	Undefined	Undefined	Undefined	Undefined	Undefined	Undefined
Read/Write	R/W	R/W	R/W	R/W	R/W	R/W	R/W	R/W

Data Length Code

0	0	0	0	Data length = 0 bytes
			1	Data length = 1 byte
		1	0	Data length = 2 bytes
			1	Data length = 3 bytes
1	0	0	0	Data length = 4 bytes
			1	Data length = 5 bytes
		1	0	Data length = 6 bytes
			1	Data length = 7 bytes
1	0/1	0/1	0/1	Data length = 8 bytes

MC7[2]

Bit	7	6	5	4	3	2	1	0
	—	—	—	—	—	—	—	—
Initial value	Undefined	Undefined	Undefined	Undefined	Undefined	Undefined	Undefined	Undefined
Read/Write	R/W	R/W	R/W	R/W	R/W	R/W	R/W	R/W

MC7[3]

Bit	7	6	5	4	3	2	1	0
	—	—	—	—	—	—	—	—
Initial value	Undefined	Undefined	Undefined	Undefined	Undefined	Undefined	Undefined	Undefined
Read/Write	R/W	R/W	R/W	R/W	R/W	R/W	R/W	R/W

MC7[4]

Bit	7	6	5	4	3	2	1	0
	—	—	—	—	—	—	—	—
Initial value	Undefined	Undefined	Undefined	Undefined	Undefined	Undefined	Undefined	Undefined
Read/Write	R/W	R/W	R/W	R/W	R/W	R/W	R/W	R/W

MC7[5]

Bit	7	6	5	4	3	2	1	0
	STD_ID2	STD_ID1	STD_ID0	RTR	IDE	—	EXD_ID17	EXD_ID16
Initial value	Undefined	Undefined	Undefined	Undefined	Undefined	Undefined	Undefined	Undefined
Read/Write	R/W	R/W	R/W	R/W	R/W	R/W	R/W	R/W

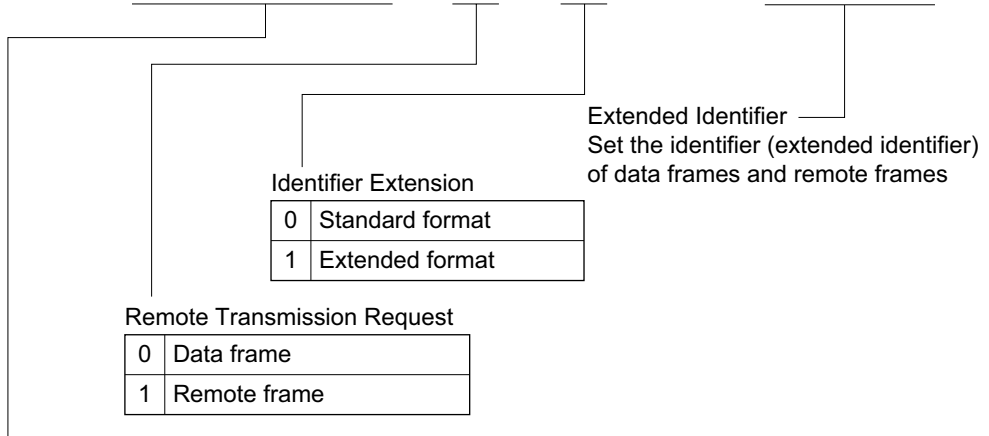

Standard Identifier

Set the identifier (standard identifier) of data frames and remote frames

MC7[6]

Bit	7	6	5	4	3	2	1	0
	STD_ID10	STD_ID9	STD_ID8	STD_ID7	STD_ID6	STD_ID5	STD_ID4	STD_ID3
Initial value	Undefined	Undefined	Undefined	Undefined	Undefined	Undefined	Undefined	Undefined
Read/Write	R/W	R/W	R/W	R/W	R/W	R/W	R/W	R/W

Standard Identifier
Set the identifier (standard identifier) of data frames and remote frames

MC7[7]

Bit	7	6	5	4	3	2	1	0
	EXD_ID7	EXD_ID6	EXD_ID5	EXD_ID4	EXD_ID3	EXD_ID2	EXD_ID1	EXD_ID0
Initial value	Undefined	Undefined	Undefined	Undefined	Undefined	Undefined	Undefined	Undefined
Read/Write	R/W	R/W	R/W	R/W	R/W	R/W	R/W	R/W

Extended Identifier _____

Set the identifier (extended identifier) of data frames and remote frames

MC7[8]

Bit	7	6	5	4	3	2	1	0
	EXD_ID15	EXD_ID14	EXD_ID13	EXD_ID12	EXD_ID11	EXD_ID10	EXD_ID9	EXD_ID8
Initial value	Undefined	Undefined	Undefined	Undefined	Undefined	Undefined	Undefined	Undefined
Read/Write	R/W	R/W	R/W	R/W	R/W	R/W	R/W	R/W

Extended Identifier _____

Set the identifier (extended identifier) of data frames and remote frames

MC8[1]—Message Control 8[1]	H'F860	HCAN0
MC8[2]—Message Control 8[2]	H'F861	HCAN0
MC8[3]—Message Control 8[3]	H'F862	HCAN0
MC8[4]—Message Control 8[4]	H'F863	HCAN0
MC8[5]—Message Control 8[5]	H'F864	HCAN0
MC8[6]—Message Control 8[6]	H'F865	HCAN0
MC8[7]—Message Control 8[7]	H'F866	HCAN0
MC8[8]—Message Control 8[8]	H'F867	HCAN0

MC8[1]

Bit	7	6	5	4	3	2	1	0
	—	—	—	—	DLC3	DLC2	DLC1	DLC0
Initial value	Undefined	Undefined	Undefined	Undefined	Undefined	Undefined	Undefined	Undefined
Read/Write	R/W	R/W	R/W	R/W	R/W	R/W	R/W	R/W

Data Length Code

0	0	0	0	Data length = 0 bytes
		1	Data length = 1 byte	
		1	0	Data length = 2 bytes
			1	Data length = 3 bytes
	1	0	0	Data length = 4 bytes
			1	Data length = 5 bytes
		1	0	Data length = 6 bytes
			1	Data length = 7 bytes
1	0/1	0/1	0/1	Data length = 8 bytes

MC8[2]

Bit	7	6	5	4	3	2	1	0
	—	—	—	—	—	—	—	—
Initial value	Undefined	Undefined	Undefined	Undefined	Undefined	Undefined	Undefined	Undefined
Read/Write	R/W	R/W	R/W	R/W	R/W	R/W	R/W	R/W

MC8[3]

Bit	7	6	5	4	3	2	1	0
	—	—	—	—	—	—	—	—
Initial value	Undefined	Undefined	Undefined	Undefined	Undefined	Undefined	Undefined	Undefined
Read/Write	R/W	R/W	R/W	R/W	R/W	R/W	R/W	R/W

MC8[4]

Bit	7	6	5	4	3	2	1	0
	—	—	—	—	—	—	—	—
Initial value	Undefined	Undefined	Undefined	Undefined	Undefined	Undefined	Undefined	Undefined
Read/Write	R/W	R/W	R/W	R/W	R/W	R/W	R/W	R/W

MC8[5]

Bit	7	6	5	4	3	2	1	0
	STD_ID2	STD_ID1	STD_ID0	RTR	IDE	—	EXD_ID17	EXD_ID16
Initial value	Undefined	Undefined	Undefined	Undefined	Undefined	Undefined	Undefined	Undefined
Read/Write	R/W	R/W	R/W	R/W	R/W	R/W	R/W	R/W

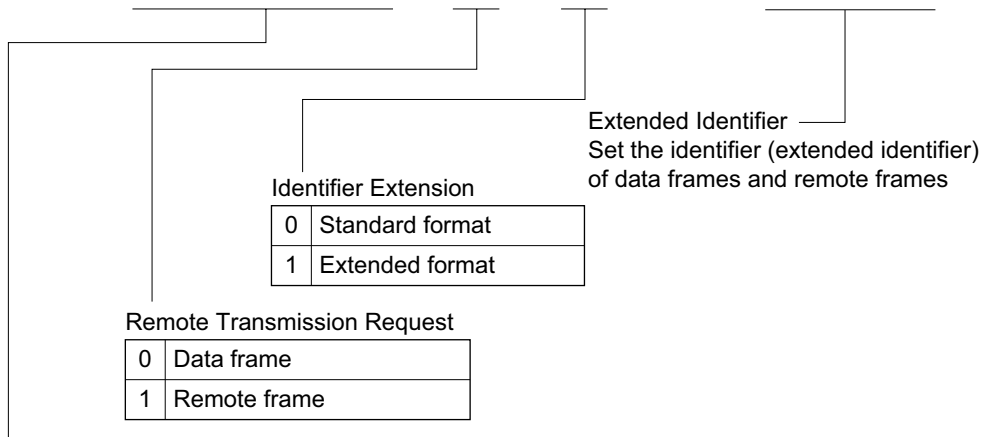

Identifier Extension

0	Standard format
1	Extended format

Remote Transmission Request

0	Data frame
1	Remote frame

Extended Identifier
Set the identifier (extended identifier) of data frames and remote frames

Standard Identifier

Set the identifier (standard identifier) of data frames and remote frames

MC8[6]

Bit	7	6	5	4	3	2	1	0
	STD_ID10	STD_ID9	STD_ID8	STD_ID7	STD_ID6	STD_ID5	STD_ID4	STD_ID3
Initial value	Undefined	Undefined	Undefined	Undefined	Undefined	Undefined	Undefined	Undefined
Read/Write	R/W	R/W	R/W	R/W	R/W	R/W	R/W	R/W

Standard Identifier
Set the identifier (standard identifier) of data frames and remote frames

MC8[7]

Bit	7	6	5	4	3	2	1	0
	EXD_ID7	EXD_ID6	EXD_ID5	EXD_ID4	EXD_ID3	EXD_ID2	EXD_ID1	EXD_ID0
Initial value	Undefined	Undefined	Undefined	Undefined	Undefined	Undefined	Undefined	Undefined
Read/Write	R/W	R/W	R/W	R/W	R/W	R/W	R/W	R/W

Extended Identifier

Set the identifier (extended identifier) of data frames and remote frames

MC8[8]

Bit	7	6	5	4	3	2	1	0
	EXD_ID15	EXD_ID14	EXD_ID13	EXD_ID12	EXD_ID11	EXD_ID10	EXD_ID9	EXD_ID8
Initial value	Undefined	Undefined	Undefined	Undefined	Undefined	Undefined	Undefined	Undefined
Read/Write	R/W	R/W	R/W	R/W	R/W	R/W	R/W	R/W

Extended Identifier

Set the identifier (extended identifier) of data frames and remote frames

MC9[1]—Message Control 9[1]	H'F868	HCAN0
MC9[2]—Message Control 9[2]	H'F869	HCAN0
MC9[3]—Message Control 9[3]	H'F86A	HCAN0
MC9[4]—Message Control 9[4]	H'F86B	HCAN0
MC9[5]—Message Control 9[5]	H'F86C	HCAN0
MC9[6]—Message Control 9[6]	H'F86D	HCAN0
MC9[7]—Message Control 9[7]	H'F86E	HCAN0
MC9[8]—Message Control 9[8]	H'F86F	HCAN0

MC9[1]

Bit	7	6	5	4	3	2	1	0
	—	—	—	—	DLC3	DLC2	DLC1	DLC0
Initial value	Undefined	Undefined	Undefined	Undefined	Undefined	Undefined	Undefined	Undefined
Read/Write	R/W	R/W	R/W	R/W	R/W	R/W	R/W	R/W

Data Length Code

0	0	0	0	Data length = 0 bytes
		1		Data length = 1 byte
		1	0	Data length = 2 bytes
			1	Data length = 3 bytes
	1	0	0	Data length = 4 bytes
			1	Data length = 5 bytes
		1	0	Data length = 6 bytes
			1	Data length = 7 bytes
1	0/1	0/1	0/1	Data length = 8 bytes

MC9[2]

Bit	7	6	5	4	3	2	1	0
	—	—	—	—	—	—	—	—
Initial value	Undefined	Undefined	Undefined	Undefined	Undefined	Undefined	Undefined	Undefined
Read/Write	R/W	R/W	R/W	R/W	R/W	R/W	R/W	R/W

MC9[3]

Bit	7	6	5	4	3	2	1	0
	—	—	—	—	—	—	—	—
Initial value	Undefined	Undefined	Undefined	Undefined	Undefined	Undefined	Undefined	Undefined
Read/Write	R/W	R/W	R/W	R/W	R/W	R/W	R/W	R/W

MC9[4]

Bit	7	6	5	4	3	2	1	0
	—	—	—	—	—	—	—	—
Initial value	Undefined	Undefined	Undefined	Undefined	Undefined	Undefined	Undefined	Undefined
Read/Write	R/W	R/W	R/W	R/W	R/W	R/W	R/W	R/W

MC9[5]

Bit	7	6	5	4	3	2	1	0
	STD_ID2	STD_ID1	STD_ID0	RTR	IDE	—	EXD_ID17	EXD_ID16
Initial value	Undefined	Undefined	Undefined	Undefined	Undefined	Undefined	Undefined	Undefined
Read/Write	R/W	R/W	R/W	R/W	R/W	R/W	R/W	R/W

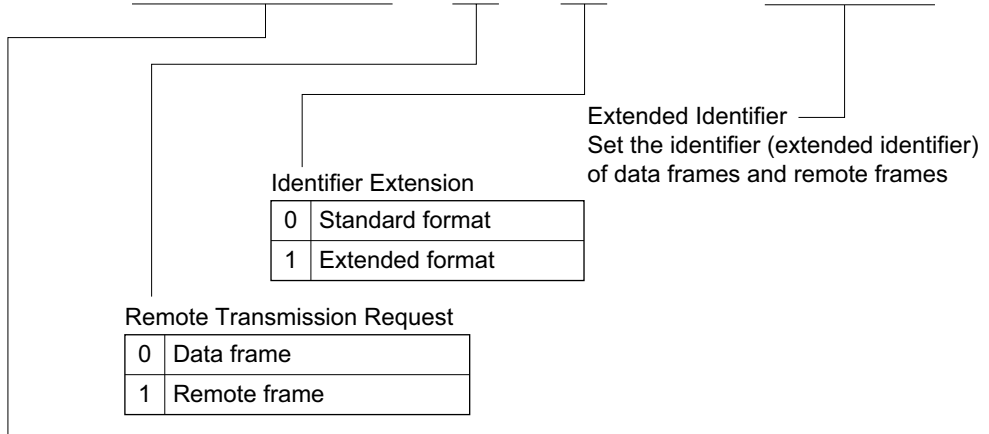

Standard Identifier

Set the identifier (standard identifier) of data frames and remote frames

MC9[6]

Bit	7	6	5	4	3	2	1	0
	STD_ID10	STD_ID9	STD_ID8	STD_ID7	STD_ID6	STD_ID5	STD_ID4	STD_ID3
Initial value	Undefined	Undefined	Undefined	Undefined	Undefined	Undefined	Undefined	Undefined
Read/Write	R/W	R/W	R/W	R/W	R/W	R/W	R/W	R/W

Standard Identifier
Set the identifier (standard identifier) of data frames and remote frames

MC9[7]

Bit	7	6	5	4	3	2	1	0
	EXD_ID7	EXD_ID6	EXD_ID5	EXD_ID4	EXD_ID3	EXD_ID2	EXD_ID1	EXD_ID0
Initial value	Undefined	Undefined	Undefined	Undefined	Undefined	Undefined	Undefined	Undefined
Read/Write	R/W	R/W	R/W	R/W	R/W	R/W	R/W	R/W

Extended Identifier

Set the identifier (extended identifier) of data frames and remote frames

MC9[8]

Bit	7	6	5	4	3	2	1	0
	EXD_ID15	EXD_ID14	EXD_ID13	EXD_ID12	EXD_ID11	EXD_ID10	EXD_ID9	EXD_ID8
Initial value	Undefined	Undefined	Undefined	Undefined	Undefined	Undefined	Undefined	Undefined
Read/Write	R/W	R/W	R/W	R/W	R/W	R/W	R/W	R/W

Extended Identifier

Set the identifier (extended identifier) of data frames and remote frames

MC10[1]—Message Control 10[1]	H'F870	HCAN0
MC10[2]—Message Control 10[2]	H'F871	HCAN0
MC10[3]—Message Control 10[3]	H'F872	HCAN0
MC10[4]—Message Control 10[4]	H'F873	HCAN0
MC10[5]—Message Control 10[5]	H'F874	HCAN0
MC10[6]—Message Control 10[6]	H'F875	HCAN0
MC10[7]—Message Control 10[7]	H'F876	HCAN0
MC10[8]—Message Control 10[8]	H'F877	HCAN0

MC10[1]

Bit	7	6	5	4	3	2	1	0
	—	—	—	—	DLC3	DLC2	DLC1	DLC0
Initial value	Undefined	Undefined	Undefined	Undefined	Undefined	Undefined	Undefined	Undefined
Read/Write	R/W	R/W	R/W	R/W	R/W	R/W	R/W	R/W

Data Length Code

0	0	0	0	Data length = 0 bytes
		1		Data length = 1 byte
		1	0	Data length = 2 bytes
			1	Data length = 3 bytes
	1	0	0	Data length = 4 bytes
			1	Data length = 5 bytes
		1	0	Data length = 6 bytes
			1	Data length = 7 bytes
1	0/1	0/1	0/1	Data length = 8 bytes

MC10[2]

Bit	7	6	5	4	3	2	1	0
	—	—	—	—	—	—	—	—
Initial value	Undefined	Undefined	Undefined	Undefined	Undefined	Undefined	Undefined	Undefined
Read/Write	R/W	R/W	R/W	R/W	R/W	R/W	R/W	R/W

MC10[3]

Bit	7	6	5	4	3	2	1	0
	—	—	—	—	—	—	—	—
Initial value	Undefined	Undefined	Undefined	Undefined	Undefined	Undefined	Undefined	Undefined
Read/Write	R/W	R/W	R/W	R/W	R/W	R/W	R/W	R/W

MC10[4]

Bit	7	6	5	4	3	2	1	0
	—	—	—	—	—	—	—	—
Initial value	Undefined	Undefined	Undefined	Undefined	Undefined	Undefined	Undefined	Undefined
Read/Write	R/W	R/W	R/W	R/W	R/W	R/W	R/W	R/W

MC10[5]

Bit	7	6	5	4	3	2	1	0
	STD_ID2	STD_ID1	STD_ID0	RTR	IDE	—	EXD_ID17	EXD_ID16
Initial value	Undefined	Undefined	Undefined	Undefined	Undefined	Undefined	Undefined	Undefined
Read/Write	R/W	R/W	R/W	R/W	R/W	R/W	R/W	R/W

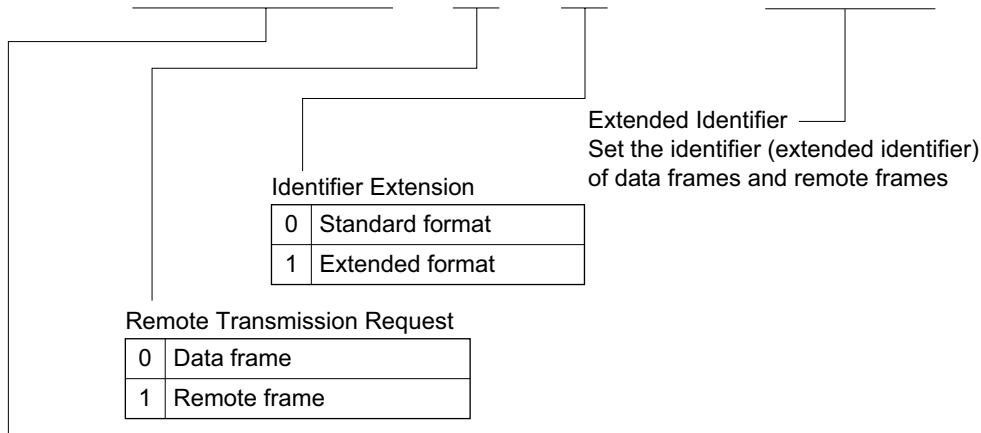

Identifier Extension

0	Standard format
1	Extended format

Remote Transmission Request

0	Data frame
1	Remote frame

Extended Identifier
Set the identifier (extended identifier) of data frames and remote frames

Standard Identifier
Set the identifier (standard identifier) of data frames and remote frames

MC10[6]

Bit	7	6	5	4	3	2	1	0
	STD_ID10	STD_ID9	STD_ID8	STD_ID7	STD_ID6	STD_ID5	STD_ID4	STD_ID3
Initial value	Undefined	Undefined	Undefined	Undefined	Undefined	Undefined	Undefined	Undefined
Read/Write	R/W	R/W	R/W	R/W	R/W	R/W	R/W	R/W

Standard Identifier
Set the identifier (standard identifier) of data frames and remote frames



MC10[7]

Bit	7	6	5	4	3	2	1	0
	EXD_ID7	EXD_ID6	EXD_ID5	EXD_ID4	EXD_ID3	EXD_ID2	EXD_ID1	EXD_ID0
Initial value	Undefined	Undefined	Undefined	Undefined	Undefined	Undefined	Undefined	Undefined
Read/Write	R/W	R/W	R/W	R/W	R/W	R/W	R/W	R/W

Extended Identifier

Set the identifier (extended identifier) of data frames and remote frames

MC10[8]

Bit	7	6	5	4	3	2	1	0
	EXD_ID15	EXD_ID14	EXD_ID13	EXD_ID12	EXD_ID11	EXD_ID10	EXD_ID9	EXD_ID8
Initial value	Undefined	Undefined	Undefined	Undefined	Undefined	Undefined	Undefined	Undefined
Read/Write	R/W	R/W	R/W	R/W	R/W	R/W	R/W	R/W

Extended Identifier

Set the identifier (extended identifier) of data frames and remote frames

MC11[1]—Message Control 11[1]	H'F878	HCAN0
MC11[2]—Message Control 11[2]	H'F879	HCAN0
MC11[3]—Message Control 11[3]	H'F87A	HCAN0
MC11[4]—Message Control 11[4]	H'F87B	HCAN0
MC11[5]—Message Control 11[5]	H'F87C	HCAN0
MC11[6]—Message Control 11[6]	H'F87D	HCAN0
MC11[7]—Message Control 11[7]	H'F87E	HCAN0
MC11[8]—Message Control 11[8]	H'F87F	HCAN0

MC11[1]

Bit	7	6	5	4	3	2	1	0
	—	—	—	—	DLC3	DLC2	DLC1	DLC0
Initial value	Undefined	Undefined	Undefined	Undefined	Undefined	Undefined	Undefined	Undefined
Read/Write	R/W	R/W	R/W	R/W	R/W	R/W	R/W	R/W

Data Length Code

0	0	0	0	Data length = 0 bytes
		1		Data length = 1 byte
		1	0	Data length = 2 bytes
			1	Data length = 3 bytes
1	0	0	Data length = 4 bytes	
		1	Data length = 5 bytes	
		1	0	Data length = 6 bytes
			1	Data length = 7 bytes
1	0/1	0/1	0/1	Data length = 8 bytes

MC11[2]

Bit	7	6	5	4	3	2	1	0
	—	—	—	—	—	—	—	—
Initial value	Undefined	Undefined	Undefined	Undefined	Undefined	Undefined	Undefined	Undefined
Read/Write	R/W	R/W	R/W	R/W	R/W	R/W	R/W	R/W

MC11[3]

Bit	7	6	5	4	3	2	1	0
	—	—	—	—	—	—	—	—
Initial value	Undefined	Undefined	Undefined	Undefined	Undefined	Undefined	Undefined	Undefined
Read/Write	R/W	R/W	R/W	R/W	R/W	R/W	R/W	R/W

MC11[4]

Bit	7	6	5	4	3	2	1	0
	—	—	—	—	—	—	—	—
Initial value	Undefined	Undefined	Undefined	Undefined	Undefined	Undefined	Undefined	Undefined
Read/Write	R/W	R/W	R/W	R/W	R/W	R/W	R/W	R/W

MC11[5]

Bit	7	6	5	4	3	2	1	0
	STD_ID2	STD_ID1	STD_ID0	RTR	IDE	—	EXD_ID17	EXD_ID16
Initial value	Undefined	Undefined	Undefined	Undefined	Undefined	Undefined	Undefined	Undefined
Read/Write	R/W	R/W	R/W	R/W	R/W	R/W	R/W	R/W

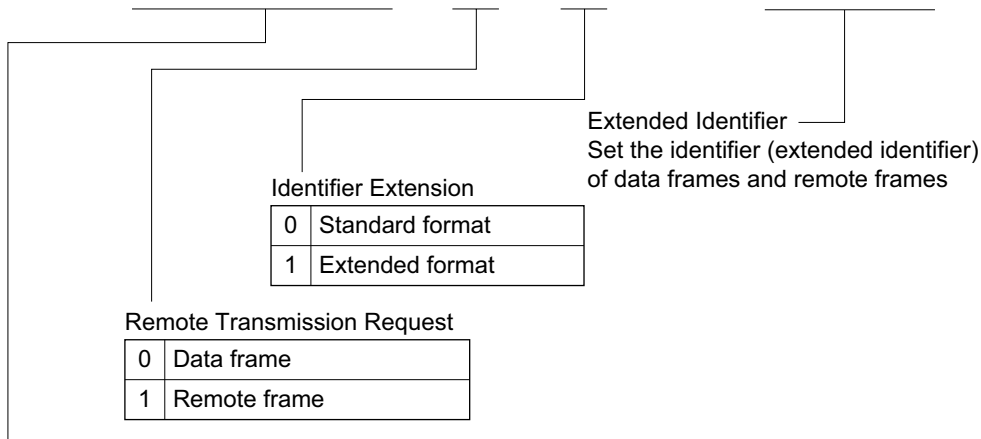

Standard Identifier

Set the identifier (standard identifier) of data frames and remote frames

MC11[6]

Bit	7	6	5	4	3	2	1	0
	STD_ID10	STD_ID9	STD_ID8	STD_ID7	STD_ID6	STD_ID5	STD_ID4	STD_ID3
Initial value	Undefined	Undefined	Undefined	Undefined	Undefined	Undefined	Undefined	Undefined
Read/Write	R/W	R/W	R/W	R/W	R/W	R/W	R/W	R/W

Standard Identifier
Set the identifier (standard identifier) of data frames and remote frames

MC11[7]

Bit	7	6	5	4	3	2	1	0
	EXD_ID7	EXD_ID6	EXD_ID5	EXD_ID4	EXD_ID3	EXD_ID2	EXD_ID1	EXD_ID0
Initial value	Undefined	Undefined	Undefined	Undefined	Undefined	Undefined	Undefined	Undefined
Read/Write	R/W	R/W	R/W	R/W	R/W	R/W	R/W	R/W

Extended Identifier _____

Set the identifier (extended identifier) of data frames and remote frames

MC11[8]

Bit	7	6	5	4	3	2	1	0
	EXD_ID15	EXD_ID14	EXD_ID13	EXD_ID12	EXD_ID11	EXD_ID10	EXD_ID9	EXD_ID8
Initial value	Undefined	Undefined	Undefined	Undefined	Undefined	Undefined	Undefined	Undefined
Read/Write	R/W	R/W	R/W	R/W	R/W	R/W	R/W	R/W

Extended Identifier _____

Set the identifier (extended identifier) of data frames and remote frames

MC12[1]—Message Control 12[1]	H'F880	HCAN0
MC12[2]—Message Control 12[2]	H'F881	HCAN0
MC12[3]—Message Control 12[3]	H'F882	HCAN0
MC12[4]—Message Control 12[4]	H'F883	HCAN0
MC12[5]—Message Control 12[5]	H'F884	HCAN0
MC12[6]—Message Control 12[6]	H'F885	HCAN0
MC12[7]—Message Control 12[7]	H'F886	HCAN0
MC12[8]—Message Control 12[8]	H'F887	HCAN0

MC12[1]

Bit	7	6	5	4	3	2	1	0
	—	—	—	—	DLC3	DLC2	DLC1	DLC0
Initial value	Undefined	Undefined	Undefined	Undefined	Undefined	Undefined	Undefined	Undefined
Read/Write	R/W	R/W	R/W	R/W	R/W	R/W	R/W	R/W

Data Length Code

0	0	0	0	Data length = 0 bytes
		1		Data length = 1 byte
		1	0	Data length = 2 bytes
			1	Data length = 3 bytes
	1	0	0	Data length = 4 bytes
			1	Data length = 5 bytes
		1	0	Data length = 6 bytes
			1	Data length = 7 bytes
1	0/1	0/1	0/1	Data length = 8 bytes

MC12[2]

Bit	7	6	5	4	3	2	1	0
	—	—	—	—	—	—	—	—
Initial value	Undefined	Undefined	Undefined	Undefined	Undefined	Undefined	Undefined	Undefined
Read/Write	R/W	R/W	R/W	R/W	R/W	R/W	R/W	R/W

MC12[3]

Bit	7	6	5	4	3	2	1	0
	—	—	—	—	—	—	—	—
Initial value	Undefined	Undefined	Undefined	Undefined	Undefined	Undefined	Undefined	Undefined
Read/Write	R/W	R/W	R/W	R/W	R/W	R/W	R/W	R/W

MC12[4]

Bit	7	6	5	4	3	2	1	0
	—	—	—	—	—	—	—	—
Initial value	Undefined	Undefined	Undefined	Undefined	Undefined	Undefined	Undefined	Undefined
Read/Write	R/W	R/W	R/W	R/W	R/W	R/W	R/W	R/W

MC12[5]

Bit	7	6	5	4	3	2	1	0
	STD_ID2	STD_ID1	STD_ID0	RTR	IDE	—	EXD_ID17	EXD_ID16
Initial value	Undefined	Undefined	Undefined	Undefined	Undefined	Undefined	Undefined	Undefined
Read/Write	R/W	R/W	R/W	R/W	R/W	R/W	R/W	R/W

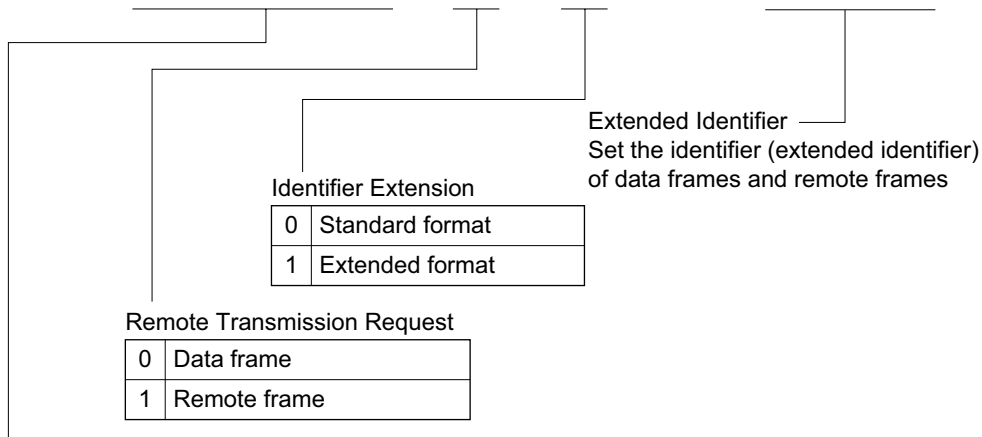

Identifier Extension

0	Standard format
1	Extended format

Remote Transmission Request

0	Data frame
1	Remote frame

Extended Identifier
Set the identifier (extended identifier) of data frames and remote frames

Standard Identifier

Set the identifier (standard identifier) of data frames and remote frames

MC12[6]

Bit	7	6	5	4	3	2	1	0
	STD_ID10	STD_ID9	STD_ID8	STD_ID7	STD_ID6	STD_ID5	STD_ID4	STD_ID3
Initial value	Undefined	Undefined	Undefined	Undefined	Undefined	Undefined	Undefined	Undefined
Read/Write	R/W	R/W	R/W	R/W	R/W	R/W	R/W	R/W

Standard Identifier
Set the identifier (standard identifier) of data frames and remote frames

MC12[7]

Bit	7	6	5	4	3	2	1	0
	EXD_ID7	EXD_ID6	EXD_ID5	EXD_ID4	EXD_ID3	EXD_ID2	EXD_ID1	EXD_ID0
Initial value	Undefined	Undefined	Undefined	Undefined	Undefined	Undefined	Undefined	Undefined
Read/Write	R/W	R/W	R/W	R/W	R/W	R/W	R/W	R/W

Extended Identifier

Set the identifier (extended identifier) of data frames and remote frames

MC12[8]

Bit	7	6	5	4	3	2	1	0
	EXD_ID15	EXD_ID14	EXD_ID13	EXD_ID12	EXD_ID11	EXD_ID10	EXD_ID9	EXD_ID8
Initial value	Undefined	Undefined	Undefined	Undefined	Undefined	Undefined	Undefined	Undefined
Read/Write	R/W	R/W	R/W	R/W	R/W	R/W	R/W	R/W

Extended Identifier

Set the identifier (extended identifier) of data frames and remote frames

MC13[1]—Message Control 13[1]	H'F888	HCAN0
MC13[2]—Message Control 13[2]	H'F889	HCAN0
MC13[3]—Message Control 13[3]	H'F88A	HCAN0
MC13[4]—Message Control 13[4]	H'F88B	HCAN0
MC13[5]—Message Control 13[5]	H'F88C	HCAN0
MC13[6]—Message Control 13[6]	H'F88D	HCAN0
MC13[7]—Message Control 13[7]	H'F88E	HCAN0
MC13[8]—Message Control 13[8]	H'F88F	HCAN0

MC13[1]

Bit	7	6	5	4	3	2	1	0
	—	—	—	—	DLC3	DLC2	DLC1	DLC0
Initial value	Undefined	Undefined	Undefined	Undefined	Undefined	Undefined	Undefined	Undefined
Read/Write	R/W	R/W	R/W	R/W	R/W	R/W	R/W	R/W

Data Length Code

0	0	0	0	Data length = 0 bytes
			1	Data length = 1 byte
		1	0	Data length = 2 bytes
			1	Data length = 3 bytes
1	0	0	0	Data length = 4 bytes
			1	Data length = 5 bytes
		1	0	Data length = 6 bytes
			1	Data length = 7 bytes
1	0/1	0/1	0/1	Data length = 8 bytes

MC13[2]

Bit	7	6	5	4	3	2	1	0
	—	—	—	—	—	—	—	—
Initial value	Undefined	Undefined	Undefined	Undefined	Undefined	Undefined	Undefined	Undefined
Read/Write	R/W	R/W	R/W	R/W	R/W	R/W	R/W	R/W

MC13[3]

Bit	7	6	5	4	3	2	1	0
	—	—	—	—	—	—	—	—
Initial value	Undefined	Undefined	Undefined	Undefined	Undefined	Undefined	Undefined	Undefined
Read/Write	R/W	R/W	R/W	R/W	R/W	R/W	R/W	R/W

MC13[4]

Bit	7	6	5	4	3	2	1	0
	—	—	—	—	—	—	—	—
Initial value	Undefined	Undefined	Undefined	Undefined	Undefined	Undefined	Undefined	Undefined
Read/Write	R/W	R/W	R/W	R/W	R/W	R/W	R/W	R/W

MC13[5]

Bit	7	6	5	4	3	2	1	0
	STD_ID2	STD_ID1	STD_ID0	RTR	IDE	—	EXD_ID17	EXD_ID16
Initial value	Undefined	Undefined	Undefined	Undefined	Undefined	Undefined	Undefined	Undefined
Read/Write	R/W	R/W	R/W	R/W	R/W	R/W	R/W	R/W

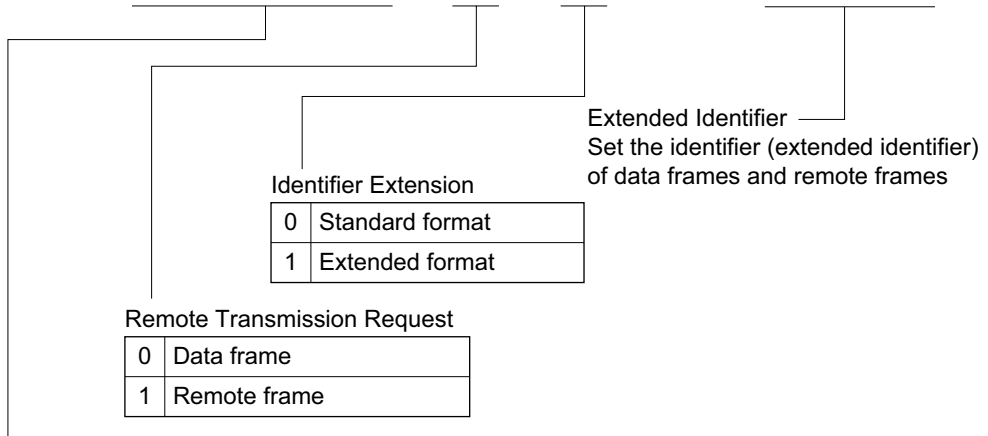

Identifier Extension

0	Standard format
1	Extended format

Remote Transmission Request

0	Data frame
1	Remote frame

Extended Identifier
Set the identifier (extended identifier) of data frames and remote frames

Standard Identifier

Set the identifier (standard identifier) of data frames and remote frames

MC13[6]

Bit	7	6	5	4	3	2	1	0
	STD_ID10	STD_ID9	STD_ID8	STD_ID7	STD_ID6	STD_ID5	STD_ID4	STD_ID3
Initial value	Undefined	Undefined	Undefined	Undefined	Undefined	Undefined	Undefined	Undefined
Read/Write	R/W	R/W	R/W	R/W	R/W	R/W	R/W	R/W

Standard Identifier
Set the identifier (standard identifier) of data frames and remote frames

MC13[7]

Bit	7	6	5	4	3	2	1	0
	EXD_ID7	EXD_ID6	EXD_ID5	EXD_ID4	EXD_ID3	EXD_ID2	EXD_ID1	EXD_ID0
Initial value	Undefined	Undefined	Undefined	Undefined	Undefined	Undefined	Undefined	Undefined
Read/Write	R/W	R/W	R/W	R/W	R/W	R/W	R/W	R/W

Extended Identifier _____

Set the identifier (extended identifier) of data frames and remote frames

MC13[8]

Bit	7	6	5	4	3	2	1	0
	EXD_ID15	EXD_ID14	EXD_ID13	EXD_ID12	EXD_ID11	EXD_ID10	EXD_ID9	EXD_ID8
Initial value	Undefined	Undefined	Undefined	Undefined	Undefined	Undefined	Undefined	Undefined
Read/Write	R/W	R/W	R/W	R/W	R/W	R/W	R/W	R/W

Extended Identifier _____

Set the identifier (extended identifier) of data frames and remote frames

MC14[1]—Message Control 14[1]	H'F890	HCAN0
MC14[2]—Message Control 14[2]	H'F891	HCAN0
MC14[3]—Message Control 14[3]	H'F892	HCAN0
MC14[4]—Message Control 14[4]	H'F893	HCAN0
MC14[5]—Message Control 14[5]	H'F894	HCAN0
MC14[6]—Message Control 14[6]	H'F895	HCAN0
MC14[7]—Message Control 14[7]	H'F896	HCAN0
MC14[8]—Message Control 14[8]	H'F897	HCAN0

MC14[1]

Bit	7	6	5	4	3	2	1	0
	—	—	—	—	DLC3	DLC2	DLC1	DLC0
Initial value	Undefined	Undefined	Undefined	Undefined	Undefined	Undefined	Undefined	Undefined
Read/Write	R/W	R/W	R/W	R/W	R/W	R/W	R/W	R/W

Data Length Code

0	0	0	0	Data length = 0 bytes
		1		Data length = 1 byte
		1	0	Data length = 2 bytes
			1	Data length = 3 bytes
	1	0	0	Data length = 4 bytes
			1	Data length = 5 bytes
		1	0	Data length = 6 bytes
			1	Data length = 7 bytes
1	0/1	0/1	0/1	Data length = 8 bytes

MC14[2]

Bit	7	6	5	4	3	2	1	0
	—	—	—	—	—	—	—	—
Initial value	Undefined	Undefined	Undefined	Undefined	Undefined	Undefined	Undefined	Undefined
Read/Write	R/W	R/W	R/W	R/W	R/W	R/W	R/W	R/W

MC14[3]

Bit	7	6	5	4	3	2	1	0
	—	—	—	—	—	—	—	—
Initial value	Undefined	Undefined	Undefined	Undefined	Undefined	Undefined	Undefined	Undefined
Read/Write	R/W	R/W	R/W	R/W	R/W	R/W	R/W	R/W

MC14[4]

Bit	7	6	5	4	3	2	1	0
	—	—	—	—	—	—	—	—
Initial value	Undefined	Undefined	Undefined	Undefined	Undefined	Undefined	Undefined	Undefined
Read/Write	R/W	R/W	R/W	R/W	R/W	R/W	R/W	R/W

MC14[5]

Bit	7	6	5	4	3	2	1	0
	STD_ID2	STD_ID1	STD_ID0	RTR	IDE	—	EXD_ID17	EXD_ID16
Initial value	Undefined	Undefined	Undefined	Undefined	Undefined	Undefined	Undefined	Undefined
Read/Write	R/W	R/W	R/W	R/W	R/W	R/W	R/W	R/W

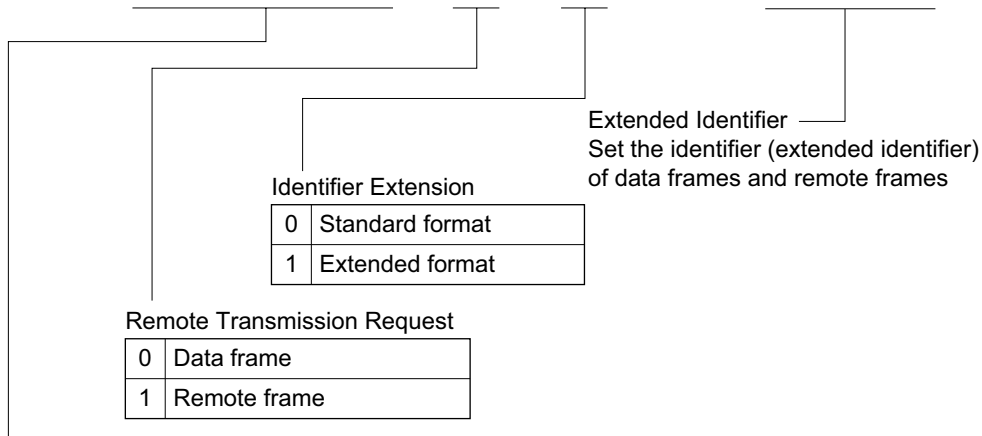

Identifier Extension

0	Standard format
1	Extended format

Remote Transmission Request

0	Data frame
1	Remote frame

Extended Identifier
Set the identifier (extended identifier)
of data frames and remote frames

Standard Identifier

Set the identifier (standard identifier) of data frames and remote frames

MC14[6]

Bit	7	6	5	4	3	2	1	0
	STD_ID10	STD_ID9	STD_ID8	STD_ID7	STD_ID6	STD_ID5	STD_ID4	STD_ID3
Initial value	Undefined	Undefined	Undefined	Undefined	Undefined	Undefined	Undefined	Undefined
Read/Write	R/W	R/W	R/W	R/W	R/W	R/W	R/W	R/W

Standard Identifier

Set the identifier (standard identifier) of data frames and remote frames

MC14[7]

Bit	7	6	5	4	3	2	1	0
	EXD_ID7	EXD_ID6	EXD_ID5	EXD_ID4	EXD_ID3	EXD_ID2	EXD_ID1	EXD_ID0
Initial value	Undefined	Undefined	Undefined	Undefined	Undefined	Undefined	Undefined	Undefined
Read/Write	R/W	R/W	R/W	R/W	R/W	R/W	R/W	R/W

Extended Identifier

Set the identifier (extended identifier) of data frames and remote frames

MC14[8]

Bit	7	6	5	4	3	2	1	0
	EXD_ID15	EXD_ID14	EXD_ID13	EXD_ID12	EXD_ID11	EXD_ID10	EXD_ID9	EXD_ID8
Initial value	Undefined	Undefined	Undefined	Undefined	Undefined	Undefined	Undefined	Undefined
Read/Write	R/W	R/W	R/W	R/W	R/W	R/W	R/W	R/W

Extended Identifier

Set the identifier (extended identifier) of data frames and remote frames

MC15[1]—Message Control 15[1]	H'F898	HCAN0
MC15[2]—Message Control 15[2]	H'F899	HCAN0
MC15[3]—Message Control 15[3]	H'F89A	HCAN0
MC15[4]—Message Control 15[4]	H'F89B	HCAN0
MC15[5]—Message Control 15[5]	H'F89C	HCAN0
MC15[6]—Message Control 15[6]	H'F89D	HCAN0
MC15[7]—Message Control 15[7]	H'F89E	HCAN0
MC15[8]—Message Control 15[8]	H'F89F	HCAN0

MC15[1]

Bit	7	6	5	4	3	2	1	0
	—	—	—	—	DLC3	DLC2	DLC1	DLC0
Initial value	Undefined	Undefined	Undefined	Undefined	Undefined	Undefined	Undefined	Undefined
Read/Write	R/W	R/W	R/W	R/W	R/W	R/W	R/W	R/W

Data Length Code

0	0	0	0	Data length = 0 bytes
		1		Data length = 1 byte
		1	0	Data length = 2 bytes
			1	Data length = 3 bytes
1	0	0	Data length = 4 bytes	
		1	Data length = 5 bytes	
		1	0	Data length = 6 bytes
			1	Data length = 7 bytes
1	0/1	0/1	0/1	Data length = 8 bytes

MC15[2]

Bit	7	6	5	4	3	2	1	0
	—	—	—	—	—	—	—	—
Initial value	Undefined	Undefined	Undefined	Undefined	Undefined	Undefined	Undefined	Undefined
Read/Write	R/W	R/W	R/W	R/W	R/W	R/W	R/W	R/W

MC15[3]

Bit	7	6	5	4	3	2	1	0
	—	—	—	—	—	—	—	—
Initial value	Undefined	Undefined	Undefined	Undefined	Undefined	Undefined	Undefined	Undefined
Read/Write	R/W	R/W	R/W	R/W	R/W	R/W	R/W	R/W

MC15[4]

Bit	7	6	5	4	3	2	1	0
	—	—	—	—	—	—	—	—
Initial value	Undefined	Undefined	Undefined	Undefined	Undefined	Undefined	Undefined	Undefined
Read/Write	R/W	R/W	R/W	R/W	R/W	R/W	R/W	R/W

MC15[5]

Bit	7	6	5	4	3	2	1	0
	STD_ID2	STD_ID1	STD_ID0	RTR	IDE	—	EXD_ID17	EXD_ID16
Initial value	Undefined	Undefined	Undefined	Undefined	Undefined	Undefined	Undefined	Undefined
Read/Write	R/W	R/W	R/W	R/W	R/W	R/W	R/W	R/W

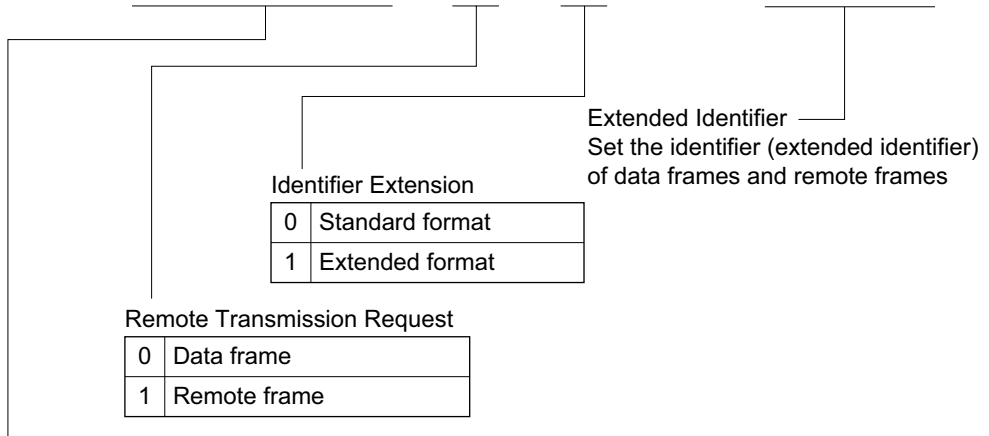

Standard Identifier

Set the identifier (standard identifier) of data frames and remote frames

MC15[6]

Bit	7	6	5	4	3	2	1	0
	STD_ID10	STD_ID9	STD_ID8	STD_ID7	STD_ID6	STD_ID5	STD_ID4	STD_ID3
Initial value	Undefined	Undefined	Undefined	Undefined	Undefined	Undefined	Undefined	Undefined
Read/Write	R/W	R/W	R/W	R/W	R/W	R/W	R/W	R/W

Standard Identifier
Set the identifier (standard identifier) of data frames and remote frames

MC15[7]

Bit	7	6	5	4	3	2	1	0
	EXD_ID7	EXD_ID6	EXD_ID5	EXD_ID4	EXD_ID3	EXD_ID2	EXD_ID1	EXD_ID0
Initial value	Undefined	Undefined	Undefined	Undefined	Undefined	Undefined	Undefined	Undefined
Read/Write	R/W	R/W	R/W	R/W	R/W	R/W	R/W	R/W

Extended Identifier _____

Set the identifier (extended identifier) of data frames and remote frames

MC15[8]

Bit	7	6	5	4	3	2	1	0
	EXD_ID15	EXD_ID14	EXD_ID13	EXD_ID12	EXD_ID11	EXD_ID10	EXD_ID9	EXD_ID8
Initial value	Undefined	Undefined	Undefined	Undefined	Undefined	Undefined	Undefined	Undefined
Read/Write	R/W	R/W	R/W	R/W	R/W	R/W	R/W	R/W

Extended Identifier _____

Set the identifier (extended identifier) of data frames and remote frames

MD0[1]—Message Data 0[1]	H'F8B0	HCAN0
MD0[2]—Message Data 0[2]	H'F8B1	HCAN0
MD0[3]—Message Data 0[3]	H'F8B2	HCAN0
MD0[4]—Message Data 0[4]	H'F8B3	HCAN0
MD0[5]—Message Data 0[5]	H'F8B4	HCAN0
MD0[6]—Message Data 0[6]	H'F8B5	HCAN0
MD0[7]—Message Data 0[7]	H'F8B6	HCAN0
MD0[8]—Message Data 0[8]	H'F8B7	HCAN0

MDx[1] Bit	7	6	5	4	3	2	1	0
	<input type="checkbox"/>	<input type="checkbox"/>	<input type="checkbox"/>	<input type="checkbox"/>	<input type="checkbox"/>	<input type="checkbox"/>	<input type="checkbox"/>	<input type="checkbox"/>
Initial value	*	*	*	*	*	*	*	*
Read/Write	R/W	R/W	R/W	R/W	R/W	R/W	R/W	R/W
MDx[2] Bit	7	6	5	4	3	2	1	0
	<input type="checkbox"/>	<input type="checkbox"/>	<input type="checkbox"/>	<input type="checkbox"/>	<input type="checkbox"/>	<input type="checkbox"/>	<input type="checkbox"/>	<input type="checkbox"/>
Initial value	*	*	*	*	*	*	*	*
Read/Write	R/W	R/W	R/W	R/W	R/W	R/W	R/W	R/W
MDx[3] Bit	7	6	5	4	3	2	1	0
	<input type="checkbox"/>	<input type="checkbox"/>	<input type="checkbox"/>	<input type="checkbox"/>	<input type="checkbox"/>	<input type="checkbox"/>	<input type="checkbox"/>	<input type="checkbox"/>
Initial value	*	*	*	*	*	*	*	*
Read/Write	R/W	R/W	R/W	R/W	R/W	R/W	R/W	R/W
MDx[4] Bit	7	6	5	4	3	2	1	0
	<input type="checkbox"/>	<input type="checkbox"/>	<input type="checkbox"/>	<input type="checkbox"/>	<input type="checkbox"/>	<input type="checkbox"/>	<input type="checkbox"/>	<input type="checkbox"/>
Initial value	*	*	*	*	*	*	*	*
Read/Write	R/W	R/W	R/W	R/W	R/W	R/W	R/W	R/W
MDx[5] Bit	7	6	5	4	3	2	1	0
	<input type="checkbox"/>	<input type="checkbox"/>	<input type="checkbox"/>	<input type="checkbox"/>	<input type="checkbox"/>	<input type="checkbox"/>	<input type="checkbox"/>	<input type="checkbox"/>
Initial value	*	*	*	*	*	*	*	*
Read/Write	R/W	R/W	R/W	R/W	R/W	R/W	R/W	R/W
MDx[6] Bit	7	6	5	4	3	2	1	0
	<input type="checkbox"/>	<input type="checkbox"/>	<input type="checkbox"/>	<input type="checkbox"/>	<input type="checkbox"/>	<input type="checkbox"/>	<input type="checkbox"/>	<input type="checkbox"/>
Initial value	*	*	*	*	*	*	*	*
Read/Write	R/W	R/W	R/W	R/W	R/W	R/W	R/W	R/W
MDx[7] Bit	7	6	5	4	3	2	1	0
	<input type="checkbox"/>	<input type="checkbox"/>	<input type="checkbox"/>	<input type="checkbox"/>	<input type="checkbox"/>	<input type="checkbox"/>	<input type="checkbox"/>	<input type="checkbox"/>
Initial value	*	*	*	*	*	*	*	*
Read/Write	R/W	R/W	R/W	R/W	R/W	R/W	R/W	R/W
MDx[8] Bit	7	6	5	4	3	2	1	0
	<input type="checkbox"/>	<input type="checkbox"/>	<input type="checkbox"/>	<input type="checkbox"/>	<input type="checkbox"/>	<input type="checkbox"/>	<input type="checkbox"/>	<input type="checkbox"/>
Initial value	*	*	*	*	*	*	*	*
Read/Write	R/W	R/W	R/W	R/W	R/W	R/W	R/W	R/W

*: Undefined
x = 0 to 15

MD1[1]—Message Data 1[1]	H'F8B8	HCAN0
MD1[2]—Message Data 1[2]	H'F8B9	HCAN0
MD1[3]—Message Data 1[3]	H'F8BA	HCAN0
MD1[4]—Message Data 1[4]	H'F8BB	HCAN0
MD1[5]—Message Data 1[5]	H'F8BC	HCAN0
MD1[6]—Message Data 1[6]	H'F8BD	HCAN0
MD1[7]—Message Data 1[7]	H'F8BE	HCAN0
MD1[8]—Message Data 1[8]	H'F8BF	HCAN0

MDx[1]	Bit	7	6	5	4	3	2	1	0										
		<table border="1"> <tr><td> </td><td> </td><td> </td><td> </td><td> </td><td> </td><td> </td><td> </td><td> </td><td> </td></tr> </table>																	
	Initial value	*	*	*	*	*	*	*	*										
	Read/Write	R/W	R/W	R/W	R/W	R/W	R/W	R/W	R/W										
MDx[2]	Bit	7	6	5	4	3	2	1	0										
		<table border="1"> <tr><td> </td><td> </td><td> </td><td> </td><td> </td><td> </td><td> </td><td> </td><td> </td><td> </td></tr> </table>																	
	Initial value	*	*	*	*	*	*	*	*										
	Read/Write	R/W	R/W	R/W	R/W	R/W	R/W	R/W	R/W										
MDx[3]	Bit	7	6	5	4	3	2	1	0										
		<table border="1"> <tr><td> </td><td> </td><td> </td><td> </td><td> </td><td> </td><td> </td><td> </td><td> </td><td> </td></tr> </table>																	
	Initial value	*	*	*	*	*	*	*	*										
	Read/Write	R/W	R/W	R/W	R/W	R/W	R/W	R/W	R/W										
MDx[4]	Bit	7	6	5	4	3	2	1	0										
		<table border="1"> <tr><td> </td><td> </td><td> </td><td> </td><td> </td><td> </td><td> </td><td> </td><td> </td><td> </td></tr> </table>																	
	Initial value	*	*	*	*	*	*	*	*										
	Read/Write	R/W	R/W	R/W	R/W	R/W	R/W	R/W	R/W										
MDx[5]	Bit	7	6	5	4	3	2	1	0										
		<table border="1"> <tr><td> </td><td> </td><td> </td><td> </td><td> </td><td> </td><td> </td><td> </td><td> </td><td> </td></tr> </table>																	
	Initial value	*	*	*	*	*	*	*	*										
	Read/Write	R/W	R/W	R/W	R/W	R/W	R/W	R/W	R/W										
MDx[6]	Bit	7	6	5	4	3	2	1	0										
		<table border="1"> <tr><td> </td><td> </td><td> </td><td> </td><td> </td><td> </td><td> </td><td> </td><td> </td><td> </td></tr> </table>																	
	Initial value	*	*	*	*	*	*	*	*										
	Read/Write	R/W	R/W	R/W	R/W	R/W	R/W	R/W	R/W										
MDx[7]	Bit	7	6	5	4	3	2	1	0										
		<table border="1"> <tr><td> </td><td> </td><td> </td><td> </td><td> </td><td> </td><td> </td><td> </td><td> </td><td> </td></tr> </table>																	
	Initial value	*	*	*	*	*	*	*	*										
	Read/Write	R/W	R/W	R/W	R/W	R/W	R/W	R/W	R/W										
MDx[8]	Bit	7	6	5	4	3	2	1	0										
		<table border="1"> <tr><td> </td><td> </td><td> </td><td> </td><td> </td><td> </td><td> </td><td> </td><td> </td><td> </td></tr> </table>																	
	Initial value	*	*	*	*	*	*	*	*										
	Read/Write	R/W	R/W	R/W	R/W	R/W	R/W	R/W	R/W										

*: Undefined
x = 0 to 15

MD2[1]—Message Data 2[1]	H'F8C0	HCAN0
MD2[2]—Message Data 2[2]	H'F8C1	HCAN0
MD2[3]—Message Data 2[3]	H'F8C2	HCAN0
MD2[4]—Message Data 2[4]	H'F8C3	HCAN0
MD2[5]—Message Data 2[5]	H'F8C4	HCAN0
MD2[6]—Message Data 2[6]	H'F8C5	HCAN0
MD2[7]—Message Data 2[7]	H'F8C6	HCAN0
MD2[8]—Message Data 2[8]	H'F8C7	HCAN0

MDx[1] Bit	7	6	5	4	3	2	1	0
	<input type="checkbox"/>	<input type="checkbox"/>	<input type="checkbox"/>	<input type="checkbox"/>	<input type="checkbox"/>	<input type="checkbox"/>	<input type="checkbox"/>	<input type="checkbox"/>
Initial value	*	*	*	*	*	*	*	*
Read/Write	R/W	R/W	R/W	R/W	R/W	R/W	R/W	R/W
MDx[2] Bit	7	6	5	4	3	2	1	0
	<input type="checkbox"/>	<input type="checkbox"/>	<input type="checkbox"/>	<input type="checkbox"/>	<input type="checkbox"/>	<input type="checkbox"/>	<input type="checkbox"/>	<input type="checkbox"/>
Initial value	*	*	*	*	*	*	*	*
Read/Write	R/W	R/W	R/W	R/W	R/W	R/W	R/W	R/W
MDx[3] Bit	7	6	5	4	3	2	1	0
	<input type="checkbox"/>	<input type="checkbox"/>	<input type="checkbox"/>	<input type="checkbox"/>	<input type="checkbox"/>	<input type="checkbox"/>	<input type="checkbox"/>	<input type="checkbox"/>
Initial value	*	*	*	*	*	*	*	*
Read/Write	R/W	R/W	R/W	R/W	R/W	R/W	R/W	R/W
MDx[4] Bit	7	6	5	4	3	2	1	0
	<input type="checkbox"/>	<input type="checkbox"/>	<input type="checkbox"/>	<input type="checkbox"/>	<input type="checkbox"/>	<input type="checkbox"/>	<input type="checkbox"/>	<input type="checkbox"/>
Initial value	*	*	*	*	*	*	*	*
Read/Write	R/W	R/W	R/W	R/W	R/W	R/W	R/W	R/W
MDx[5] Bit	7	6	5	4	3	2	1	0
	<input type="checkbox"/>	<input type="checkbox"/>	<input type="checkbox"/>	<input type="checkbox"/>	<input type="checkbox"/>	<input type="checkbox"/>	<input type="checkbox"/>	<input type="checkbox"/>
Initial value	*	*	*	*	*	*	*	*
Read/Write	R/W	R/W	R/W	R/W	R/W	R/W	R/W	R/W
MDx[6] Bit	7	6	5	4	3	2	1	0
	<input type="checkbox"/>	<input type="checkbox"/>	<input type="checkbox"/>	<input type="checkbox"/>	<input type="checkbox"/>	<input type="checkbox"/>	<input type="checkbox"/>	<input type="checkbox"/>
Initial value	*	*	*	*	*	*	*	*
Read/Write	R/W	R/W	R/W	R/W	R/W	R/W	R/W	R/W
MDx[7] Bit	7	6	5	4	3	2	1	0
	<input type="checkbox"/>	<input type="checkbox"/>	<input type="checkbox"/>	<input type="checkbox"/>	<input type="checkbox"/>	<input type="checkbox"/>	<input type="checkbox"/>	<input type="checkbox"/>
Initial value	*	*	*	*	*	*	*	*
Read/Write	R/W	R/W	R/W	R/W	R/W	R/W	R/W	R/W
MDx[8] Bit	7	6	5	4	3	2	1	0
	<input type="checkbox"/>	<input type="checkbox"/>	<input type="checkbox"/>	<input type="checkbox"/>	<input type="checkbox"/>	<input type="checkbox"/>	<input type="checkbox"/>	<input type="checkbox"/>
Initial value	*	*	*	*	*	*	*	*
Read/Write	R/W	R/W	R/W	R/W	R/W	R/W	R/W	R/W

*: Undefined
x = 0 to 15

MD3[1]—Message Data 3[1]	H'F8C8	HCAN0
MD3[2]—Message Data 3[2]	H'F8C9	HCAN0
MD3[3]—Message Data 3[3]	H'F8CA	HCAN0
MD3[4]—Message Data 3[4]	H'F8CB	HCAN0
MD3[5]—Message Data 3[5]	H'F8CC	HCAN0
MD3[6]—Message Data 3[6]	H'F8CD	HCAN0
MD3[7]—Message Data 3[7]	H'F8CE	HCAN0
MD3[8]—Message Data 3[8]	H'F8CF	HCAN0

MDx[1]	Bit	7	6	5	4	3	2	1	0
		<input type="checkbox"/>	<input type="checkbox"/>	<input type="checkbox"/>	<input type="checkbox"/>	<input type="checkbox"/>	<input type="checkbox"/>	<input type="checkbox"/>	<input type="checkbox"/>
	Initial value	*	*	*	*	*	*	*	*
	Read/Write	R/W	R/W	R/W	R/W	R/W	R/W	R/W	R/W
MDx[2]	Bit	7	6	5	4	3	2	1	0
		<input type="checkbox"/>	<input type="checkbox"/>	<input type="checkbox"/>	<input type="checkbox"/>	<input type="checkbox"/>	<input type="checkbox"/>	<input type="checkbox"/>	<input type="checkbox"/>
	Initial value	*	*	*	*	*	*	*	*
	Read/Write	R/W	R/W	R/W	R/W	R/W	R/W	R/W	R/W
MDx[3]	Bit	7	6	5	4	3	2	1	0
		<input type="checkbox"/>	<input type="checkbox"/>	<input type="checkbox"/>	<input type="checkbox"/>	<input type="checkbox"/>	<input type="checkbox"/>	<input type="checkbox"/>	<input type="checkbox"/>
	Initial value	*	*	*	*	*	*	*	*
	Read/Write	R/W	R/W	R/W	R/W	R/W	R/W	R/W	R/W
MDx[4]	Bit	7	6	5	4	3	2	1	0
		<input type="checkbox"/>	<input type="checkbox"/>	<input type="checkbox"/>	<input type="checkbox"/>	<input type="checkbox"/>	<input type="checkbox"/>	<input type="checkbox"/>	<input type="checkbox"/>
	Initial value	*	*	*	*	*	*	*	*
	Read/Write	R/W	R/W	R/W	R/W	R/W	R/W	R/W	R/W
MDx[5]	Bit	7	6	5	4	3	2	1	0
		<input type="checkbox"/>	<input type="checkbox"/>	<input type="checkbox"/>	<input type="checkbox"/>	<input type="checkbox"/>	<input type="checkbox"/>	<input type="checkbox"/>	<input type="checkbox"/>
	Initial value	*	*	*	*	*	*	*	*
	Read/Write	R/W	R/W	R/W	R/W	R/W	R/W	R/W	R/W
MDx[6]	Bit	7	6	5	4	3	2	1	0
		<input type="checkbox"/>	<input type="checkbox"/>	<input type="checkbox"/>	<input type="checkbox"/>	<input type="checkbox"/>	<input type="checkbox"/>	<input type="checkbox"/>	<input type="checkbox"/>
	Initial value	*	*	*	*	*	*	*	*
	Read/Write	R/W	R/W	R/W	R/W	R/W	R/W	R/W	R/W
MDx[7]	Bit	7	6	5	4	3	2	1	0
		<input type="checkbox"/>	<input type="checkbox"/>	<input type="checkbox"/>	<input type="checkbox"/>	<input type="checkbox"/>	<input type="checkbox"/>	<input type="checkbox"/>	<input type="checkbox"/>
	Initial value	*	*	*	*	*	*	*	*
	Read/Write	R/W	R/W	R/W	R/W	R/W	R/W	R/W	R/W
MDx[8]	Bit	7	6	5	4	3	2	1	0
		<input type="checkbox"/>	<input type="checkbox"/>	<input type="checkbox"/>	<input type="checkbox"/>	<input type="checkbox"/>	<input type="checkbox"/>	<input type="checkbox"/>	<input type="checkbox"/>
	Initial value	*	*	*	*	*	*	*	*
	Read/Write	R/W	R/W	R/W	R/W	R/W	R/W	R/W	R/W

*: Undefined
x = 0 to 15

MD4[1]—Message Data 4[1]	H'F8D0	HCAN0
MD4[2]—Message Data 4[2]	H'F8D1	HCAN0
MD4[3]—Message Data 4[3]	H'F8D2	HCAN0
MD4[4]—Message Data 4[4]	H'F8D3	HCAN0
MD4[5]—Message Data 4[5]	H'F8D4	HCAN0
MD4[6]—Message Data 4[6]	H'F8D5	HCAN0
MD4[7]—Message Data 4[7]	H'F8D6	HCAN0
MD4[8]—Message Data 4[8]	H'F8D7	HCAN0

MDx[1] Bit	7	6	5	4	3	2	1	0
	<input type="checkbox"/>	<input type="checkbox"/>	<input type="checkbox"/>	<input type="checkbox"/>	<input type="checkbox"/>	<input type="checkbox"/>	<input type="checkbox"/>	<input type="checkbox"/>
Initial value	*	*	*	*	*	*	*	*
Read/Write	R/W	R/W	R/W	R/W	R/W	R/W	R/W	R/W
MDx[2] Bit	7	6	5	4	3	2	1	0
	<input type="checkbox"/>	<input type="checkbox"/>	<input type="checkbox"/>	<input type="checkbox"/>	<input type="checkbox"/>	<input type="checkbox"/>	<input type="checkbox"/>	<input type="checkbox"/>
Initial value	*	*	*	*	*	*	*	*
Read/Write	R/W	R/W	R/W	R/W	R/W	R/W	R/W	R/W
MDx[3] Bit	7	6	5	4	3	2	1	0
	<input type="checkbox"/>	<input type="checkbox"/>	<input type="checkbox"/>	<input type="checkbox"/>	<input type="checkbox"/>	<input type="checkbox"/>	<input type="checkbox"/>	<input type="checkbox"/>
Initial value	*	*	*	*	*	*	*	*
Read/Write	R/W	R/W	R/W	R/W	R/W	R/W	R/W	R/W
MDx[4] Bit	7	6	5	4	3	2	1	0
	<input type="checkbox"/>	<input type="checkbox"/>	<input type="checkbox"/>	<input type="checkbox"/>	<input type="checkbox"/>	<input type="checkbox"/>	<input type="checkbox"/>	<input type="checkbox"/>
Initial value	*	*	*	*	*	*	*	*
Read/Write	R/W	R/W	R/W	R/W	R/W	R/W	R/W	R/W
MDx[5] Bit	7	6	5	4	3	2	1	0
	<input type="checkbox"/>	<input type="checkbox"/>	<input type="checkbox"/>	<input type="checkbox"/>	<input type="checkbox"/>	<input type="checkbox"/>	<input type="checkbox"/>	<input type="checkbox"/>
Initial value	*	*	*	*	*	*	*	*
Read/Write	R/W	R/W	R/W	R/W	R/W	R/W	R/W	R/W
MDx[6] Bit	7	6	5	4	3	2	1	0
	<input type="checkbox"/>	<input type="checkbox"/>	<input type="checkbox"/>	<input type="checkbox"/>	<input type="checkbox"/>	<input type="checkbox"/>	<input type="checkbox"/>	<input type="checkbox"/>
Initial value	*	*	*	*	*	*	*	*
Read/Write	R/W	R/W	R/W	R/W	R/W	R/W	R/W	R/W
MDx[7] Bit	7	6	5	4	3	2	1	0
	<input type="checkbox"/>	<input type="checkbox"/>	<input type="checkbox"/>	<input type="checkbox"/>	<input type="checkbox"/>	<input type="checkbox"/>	<input type="checkbox"/>	<input type="checkbox"/>
Initial value	*	*	*	*	*	*	*	*
Read/Write	R/W	R/W	R/W	R/W	R/W	R/W	R/W	R/W
MDx[8] Bit	7	6	5	4	3	2	1	0
	<input type="checkbox"/>	<input type="checkbox"/>	<input type="checkbox"/>	<input type="checkbox"/>	<input type="checkbox"/>	<input type="checkbox"/>	<input type="checkbox"/>	<input type="checkbox"/>
Initial value	*	*	*	*	*	*	*	*
Read/Write	R/W	R/W	R/W	R/W	R/W	R/W	R/W	R/W

*: Undefined
x = 0 to 15

MD5[1]—Message Data 5[1]	H'F8D8	HCAN0
MD5[2]—Message Data 5[2]	H'F8D9	HCAN0
MD5[3]—Message Data 5[3]	H'F8DA	HCAN0
MD5[4]—Message Data 5[4]	H'F8DB	HCAN0
MD5[5]—Message Data 5[5]	H'F8DC	HCAN0
MD5[6]—Message Data 5[6]	H'F8DD	HCAN0
MD5[7]—Message Data 5[7]	H'F8DE	HCAN0
MD5[8]—Message Data 5[8]	H'F8DF	HCAN0

MDx[1]	Bit	7	6	5	4	3	2	1	0										
		<table border="1"> <tr><td> </td><td> </td><td> </td><td> </td><td> </td><td> </td><td> </td><td> </td><td> </td><td> </td></tr> </table>																	
	Initial value	*	*	*	*	*	*	*	*										
	Read/Write	R/W	R/W	R/W	R/W	R/W	R/W	R/W	R/W										
MDx[2]	Bit	7	6	5	4	3	2	1	0										
		<table border="1"> <tr><td> </td><td> </td><td> </td><td> </td><td> </td><td> </td><td> </td><td> </td><td> </td><td> </td></tr> </table>																	
	Initial value	*	*	*	*	*	*	*	*										
	Read/Write	R/W	R/W	R/W	R/W	R/W	R/W	R/W	R/W										
MDx[3]	Bit	7	6	5	4	3	2	1	0										
		<table border="1"> <tr><td> </td><td> </td><td> </td><td> </td><td> </td><td> </td><td> </td><td> </td><td> </td><td> </td></tr> </table>																	
	Initial value	*	*	*	*	*	*	*	*										
	Read/Write	R/W	R/W	R/W	R/W	R/W	R/W	R/W	R/W										
MDx[4]	Bit	7	6	5	4	3	2	1	0										
		<table border="1"> <tr><td> </td><td> </td><td> </td><td> </td><td> </td><td> </td><td> </td><td> </td><td> </td><td> </td></tr> </table>																	
	Initial value	*	*	*	*	*	*	*	*										
	Read/Write	R/W	R/W	R/W	R/W	R/W	R/W	R/W	R/W										
MDx[5]	Bit	7	6	5	4	3	2	1	0										
		<table border="1"> <tr><td> </td><td> </td><td> </td><td> </td><td> </td><td> </td><td> </td><td> </td><td> </td><td> </td></tr> </table>																	
	Initial value	*	*	*	*	*	*	*	*										
	Read/Write	R/W	R/W	R/W	R/W	R/W	R/W	R/W	R/W										
MDx[6]	Bit	7	6	5	4	3	2	1	0										
		<table border="1"> <tr><td> </td><td> </td><td> </td><td> </td><td> </td><td> </td><td> </td><td> </td><td> </td><td> </td></tr> </table>																	
	Initial value	*	*	*	*	*	*	*	*										
	Read/Write	R/W	R/W	R/W	R/W	R/W	R/W	R/W	R/W										
MDx[7]	Bit	7	6	5	4	3	2	1	0										
		<table border="1"> <tr><td> </td><td> </td><td> </td><td> </td><td> </td><td> </td><td> </td><td> </td><td> </td><td> </td></tr> </table>																	
	Initial value	*	*	*	*	*	*	*	*										
	Read/Write	R/W	R/W	R/W	R/W	R/W	R/W	R/W	R/W										
MDx[8]	Bit	7	6	5	4	3	2	1	0										
		<table border="1"> <tr><td> </td><td> </td><td> </td><td> </td><td> </td><td> </td><td> </td><td> </td><td> </td><td> </td></tr> </table>																	
	Initial value	*	*	*	*	*	*	*	*										
	Read/Write	R/W	R/W	R/W	R/W	R/W	R/W	R/W	R/W										

*: Undefined
x = 0 to 15

MD6[1]—Message Data 6[1]	H'F8E0	HCAN0
MD6[2]—Message Data 6[2]	H'F8E1	HCAN0
MD6[3]—Message Data 6[3]	H'F8E2	HCAN0
MD6[4]—Message Data 6[4]	H'F8E3	HCAN0
MD6[5]—Message Data 6[5]	H'F8E4	HCAN0
MD6[6]—Message Data 6[6]	H'F8E5	HCAN0
MD6[7]—Message Data 6[7]	H'F8E6	HCAN0
MD6[8]—Message Data 6[8]	H'F8E7	HCAN0

MDx[1] Bit	7	6	5	4	3	2	1	0
	<input type="checkbox"/>	<input type="checkbox"/>	<input type="checkbox"/>	<input type="checkbox"/>	<input type="checkbox"/>	<input type="checkbox"/>	<input type="checkbox"/>	<input type="checkbox"/>
Initial value	*	*	*	*	*	*	*	*
Read/Write	R/W	R/W	R/W	R/W	R/W	R/W	R/W	R/W
MDx[2] Bit	7	6	5	4	3	2	1	0
	<input type="checkbox"/>	<input type="checkbox"/>	<input type="checkbox"/>	<input type="checkbox"/>	<input type="checkbox"/>	<input type="checkbox"/>	<input type="checkbox"/>	<input type="checkbox"/>
Initial value	*	*	*	*	*	*	*	*
Read/Write	R/W	R/W	R/W	R/W	R/W	R/W	R/W	R/W
MDx[3] Bit	7	6	5	4	3	2	1	0
	<input type="checkbox"/>	<input type="checkbox"/>	<input type="checkbox"/>	<input type="checkbox"/>	<input type="checkbox"/>	<input type="checkbox"/>	<input type="checkbox"/>	<input type="checkbox"/>
Initial value	*	*	*	*	*	*	*	*
Read/Write	R/W	R/W	R/W	R/W	R/W	R/W	R/W	R/W
MDx[4] Bit	7	6	5	4	3	2	1	0
	<input type="checkbox"/>	<input type="checkbox"/>	<input type="checkbox"/>	<input type="checkbox"/>	<input type="checkbox"/>	<input type="checkbox"/>	<input type="checkbox"/>	<input type="checkbox"/>
Initial value	*	*	*	*	*	*	*	*
Read/Write	R/W	R/W	R/W	R/W	R/W	R/W	R/W	R/W
MDx[5] Bit	7	6	5	4	3	2	1	0
	<input type="checkbox"/>	<input type="checkbox"/>	<input type="checkbox"/>	<input type="checkbox"/>	<input type="checkbox"/>	<input type="checkbox"/>	<input type="checkbox"/>	<input type="checkbox"/>
Initial value	*	*	*	*	*	*	*	*
Read/Write	R/W	R/W	R/W	R/W	R/W	R/W	R/W	R/W
MDx[6] Bit	7	6	5	4	3	2	1	0
	<input type="checkbox"/>	<input type="checkbox"/>	<input type="checkbox"/>	<input type="checkbox"/>	<input type="checkbox"/>	<input type="checkbox"/>	<input type="checkbox"/>	<input type="checkbox"/>
Initial value	*	*	*	*	*	*	*	*
Read/Write	R/W	R/W	R/W	R/W	R/W	R/W	R/W	R/W
MDx[7] Bit	7	6	5	4	3	2	1	0
	<input type="checkbox"/>	<input type="checkbox"/>	<input type="checkbox"/>	<input type="checkbox"/>	<input type="checkbox"/>	<input type="checkbox"/>	<input type="checkbox"/>	<input type="checkbox"/>
Initial value	*	*	*	*	*	*	*	*
Read/Write	R/W	R/W	R/W	R/W	R/W	R/W	R/W	R/W
MDx[8] Bit	7	6	5	4	3	2	1	0
	<input type="checkbox"/>	<input type="checkbox"/>	<input type="checkbox"/>	<input type="checkbox"/>	<input type="checkbox"/>	<input type="checkbox"/>	<input type="checkbox"/>	<input type="checkbox"/>
Initial value	*	*	*	*	*	*	*	*
Read/Write	R/W	R/W	R/W	R/W	R/W	R/W	R/W	R/W

*: Undefined
x = 0 to 15

MD7[1]—Message Data 7[1]	H'F8E8	HCAN0
MD7[2]—Message Data 7[2]	H'F8E9	HCAN0
MD7[3]—Message Data 7[3]	H'F8EA	HCAN0
MD7[4]—Message Data 7[4]	H'F8EB	HCAN0
MD7[5]—Message Data 7[5]	H'F8EC	HCAN0
MD7[6]—Message Data 7[6]	H'F8ED	HCAN0
MD7[7]—Message Data 7[7]	H'F8EE	HCAN0
MD7[8]—Message Data 7[8]	H'F8EF	HCAN0

MDx[1]	Bit	7	6	5	4	3	2	1	0										
		<table border="1"> <tr><td> </td><td> </td><td> </td><td> </td><td> </td><td> </td><td> </td><td> </td><td> </td><td> </td></tr> </table>																	
	Initial value	*	*	*	*	*	*	*	*										
	Read/Write	R/W	R/W	R/W	R/W	R/W	R/W	R/W	R/W										
MDx[2]	Bit	7	6	5	4	3	2	1	0										
		<table border="1"> <tr><td> </td><td> </td><td> </td><td> </td><td> </td><td> </td><td> </td><td> </td><td> </td><td> </td></tr> </table>																	
	Initial value	*	*	*	*	*	*	*	*										
	Read/Write	R/W	R/W	R/W	R/W	R/W	R/W	R/W	R/W										
MDx[3]	Bit	7	6	5	4	3	2	1	0										
		<table border="1"> <tr><td> </td><td> </td><td> </td><td> </td><td> </td><td> </td><td> </td><td> </td><td> </td><td> </td></tr> </table>																	
	Initial value	*	*	*	*	*	*	*	*										
	Read/Write	R/W	R/W	R/W	R/W	R/W	R/W	R/W	R/W										
MDx[4]	Bit	7	6	5	4	3	2	1	0										
		<table border="1"> <tr><td> </td><td> </td><td> </td><td> </td><td> </td><td> </td><td> </td><td> </td><td> </td><td> </td></tr> </table>																	
	Initial value	*	*	*	*	*	*	*	*										
	Read/Write	R/W	R/W	R/W	R/W	R/W	R/W	R/W	R/W										
MDx[5]	Bit	7	6	5	4	3	2	1	0										
		<table border="1"> <tr><td> </td><td> </td><td> </td><td> </td><td> </td><td> </td><td> </td><td> </td><td> </td><td> </td></tr> </table>																	
	Initial value	*	*	*	*	*	*	*	*										
	Read/Write	R/W	R/W	R/W	R/W	R/W	R/W	R/W	R/W										
MDx[6]	Bit	7	6	5	4	3	2	1	0										
		<table border="1"> <tr><td> </td><td> </td><td> </td><td> </td><td> </td><td> </td><td> </td><td> </td><td> </td><td> </td></tr> </table>																	
	Initial value	*	*	*	*	*	*	*	*										
	Read/Write	R/W	R/W	R/W	R/W	R/W	R/W	R/W	R/W										
MDx[7]	Bit	7	6	5	4	3	2	1	0										
		<table border="1"> <tr><td> </td><td> </td><td> </td><td> </td><td> </td><td> </td><td> </td><td> </td><td> </td><td> </td></tr> </table>																	
	Initial value	*	*	*	*	*	*	*	*										
	Read/Write	R/W	R/W	R/W	R/W	R/W	R/W	R/W	R/W										
MDx[8]	Bit	7	6	5	4	3	2	1	0										
		<table border="1"> <tr><td> </td><td> </td><td> </td><td> </td><td> </td><td> </td><td> </td><td> </td><td> </td><td> </td></tr> </table>																	
	Initial value	*	*	*	*	*	*	*	*										
	Read/Write	R/W	R/W	R/W	R/W	R/W	R/W	R/W	R/W										

*: Undefined
x = 0 to 15

MD8[1]—Message Data 8[1]	H'F8F0	HCAN0
MD8[2]—Message Data 8[2]	H'F8F1	HCAN0
MD8[3]—Message Data 8[3]	H'F8F2	HCAN0
MD8[4]—Message Data 8[4]	H'F8F3	HCAN0
MD8[5]—Message Data 8[5]	H'F8F4	HCAN0
MD8[6]—Message Data 8[6]	H'F8F5	HCAN0
MD8[7]—Message Data 8[7]	H'F8F6	HCAN0
MD8[8]—Message Data 8[8]	H'F8F7	HCAN0

MDx[1] Bit	7	6	5	4	3	2	1	0
	<input type="checkbox"/>	<input type="checkbox"/>	<input type="checkbox"/>	<input type="checkbox"/>	<input type="checkbox"/>	<input type="checkbox"/>	<input type="checkbox"/>	<input type="checkbox"/>
Initial value	*	*	*	*	*	*	*	*
Read/Write	R/W	R/W	R/W	R/W	R/W	R/W	R/W	R/W
MDx[2] Bit	7	6	5	4	3	2	1	0
	<input type="checkbox"/>	<input type="checkbox"/>	<input type="checkbox"/>	<input type="checkbox"/>	<input type="checkbox"/>	<input type="checkbox"/>	<input type="checkbox"/>	<input type="checkbox"/>
Initial value	*	*	*	*	*	*	*	*
Read/Write	R/W	R/W	R/W	R/W	R/W	R/W	R/W	R/W
MDx[3] Bit	7	6	5	4	3	2	1	0
	<input type="checkbox"/>	<input type="checkbox"/>	<input type="checkbox"/>	<input type="checkbox"/>	<input type="checkbox"/>	<input type="checkbox"/>	<input type="checkbox"/>	<input type="checkbox"/>
Initial value	*	*	*	*	*	*	*	*
Read/Write	R/W	R/W	R/W	R/W	R/W	R/W	R/W	R/W
MDx[4] Bit	7	6	5	4	3	2	1	0
	<input type="checkbox"/>	<input type="checkbox"/>	<input type="checkbox"/>	<input type="checkbox"/>	<input type="checkbox"/>	<input type="checkbox"/>	<input type="checkbox"/>	<input type="checkbox"/>
Initial value	*	*	*	*	*	*	*	*
Read/Write	R/W	R/W	R/W	R/W	R/W	R/W	R/W	R/W
MDx[5] Bit	7	6	5	4	3	2	1	0
	<input type="checkbox"/>	<input type="checkbox"/>	<input type="checkbox"/>	<input type="checkbox"/>	<input type="checkbox"/>	<input type="checkbox"/>	<input type="checkbox"/>	<input type="checkbox"/>
Initial value	*	*	*	*	*	*	*	*
Read/Write	R/W	R/W	R/W	R/W	R/W	R/W	R/W	R/W
MDx[6] Bit	7	6	5	4	3	2	1	0
	<input type="checkbox"/>	<input type="checkbox"/>	<input type="checkbox"/>	<input type="checkbox"/>	<input type="checkbox"/>	<input type="checkbox"/>	<input type="checkbox"/>	<input type="checkbox"/>
Initial value	*	*	*	*	*	*	*	*
Read/Write	R/W	R/W	R/W	R/W	R/W	R/W	R/W	R/W
MDx[7] Bit	7	6	5	4	3	2	1	0
	<input type="checkbox"/>	<input type="checkbox"/>	<input type="checkbox"/>	<input type="checkbox"/>	<input type="checkbox"/>	<input type="checkbox"/>	<input type="checkbox"/>	<input type="checkbox"/>
Initial value	*	*	*	*	*	*	*	*
Read/Write	R/W	R/W	R/W	R/W	R/W	R/W	R/W	R/W
MDx[8] Bit	7	6	5	4	3	2	1	0
	<input type="checkbox"/>	<input type="checkbox"/>	<input type="checkbox"/>	<input type="checkbox"/>	<input type="checkbox"/>	<input type="checkbox"/>	<input type="checkbox"/>	<input type="checkbox"/>
Initial value	*	*	*	*	*	*	*	*
Read/Write	R/W	R/W	R/W	R/W	R/W	R/W	R/W	R/W

*: Undefined
x = 0 to 15

MD9[1]—Message Data 9[1]	H'F8F8	HCAN0
MD9[2]—Message Data 9[2]	H'F8F9	HCAN0
MD9[3]—Message Data 9[3]	H'F8FA	HCAN0
MD9[4]—Message Data 9[4]	H'F8FB	HCAN0
MD9[5]—Message Data 9[5]	H'F8FC	HCAN0
MD9[6]—Message Data 9[6]	H'F8FD	HCAN0
MD9[7]—Message Data 9[7]	H'F8FE	HCAN0
MD9[8]—Message Data 9[8]	H'F8FF	HCAN0

MDx[1]	Bit	7	6	5	4	3	2	1	0
		<input type="checkbox"/>	<input type="checkbox"/>	<input type="checkbox"/>	<input type="checkbox"/>	<input type="checkbox"/>	<input type="checkbox"/>	<input type="checkbox"/>	<input type="checkbox"/>
	Initial value	*	*	*	*	*	*	*	*
	Read/Write	R/W	R/W	R/W	R/W	R/W	R/W	R/W	R/W
MDx[2]	Bit	7	6	5	4	3	2	1	0
		<input type="checkbox"/>	<input type="checkbox"/>	<input type="checkbox"/>	<input type="checkbox"/>	<input type="checkbox"/>	<input type="checkbox"/>	<input type="checkbox"/>	<input type="checkbox"/>
	Initial value	*	*	*	*	*	*	*	*
	Read/Write	R/W	R/W	R/W	R/W	R/W	R/W	R/W	R/W
MDx[3]	Bit	7	6	5	4	3	2	1	0
		<input type="checkbox"/>	<input type="checkbox"/>	<input type="checkbox"/>	<input type="checkbox"/>	<input type="checkbox"/>	<input type="checkbox"/>	<input type="checkbox"/>	<input type="checkbox"/>
	Initial value	*	*	*	*	*	*	*	*
	Read/Write	R/W	R/W	R/W	R/W	R/W	R/W	R/W	R/W
MDx[4]	Bit	7	6	5	4	3	2	1	0
		<input type="checkbox"/>	<input type="checkbox"/>	<input type="checkbox"/>	<input type="checkbox"/>	<input type="checkbox"/>	<input type="checkbox"/>	<input type="checkbox"/>	<input type="checkbox"/>
	Initial value	*	*	*	*	*	*	*	*
	Read/Write	R/W	R/W	R/W	R/W	R/W	R/W	R/W	R/W
MDx[5]	Bit	7	6	5	4	3	2	1	0
		<input type="checkbox"/>	<input type="checkbox"/>	<input type="checkbox"/>	<input type="checkbox"/>	<input type="checkbox"/>	<input type="checkbox"/>	<input type="checkbox"/>	<input type="checkbox"/>
	Initial value	*	*	*	*	*	*	*	*
	Read/Write	R/W	R/W	R/W	R/W	R/W	R/W	R/W	R/W
MDx[6]	Bit	7	6	5	4	3	2	1	0
		<input type="checkbox"/>	<input type="checkbox"/>	<input type="checkbox"/>	<input type="checkbox"/>	<input type="checkbox"/>	<input type="checkbox"/>	<input type="checkbox"/>	<input type="checkbox"/>
	Initial value	*	*	*	*	*	*	*	*
	Read/Write	R/W	R/W	R/W	R/W	R/W	R/W	R/W	R/W
MDx[7]	Bit	7	6	5	4	3	2	1	0
		<input type="checkbox"/>	<input type="checkbox"/>	<input type="checkbox"/>	<input type="checkbox"/>	<input type="checkbox"/>	<input type="checkbox"/>	<input type="checkbox"/>	<input type="checkbox"/>
	Initial value	*	*	*	*	*	*	*	*
	Read/Write	R/W	R/W	R/W	R/W	R/W	R/W	R/W	R/W
MDx[8]	Bit	7	6	5	4	3	2	1	0
		<input type="checkbox"/>	<input type="checkbox"/>	<input type="checkbox"/>	<input type="checkbox"/>	<input type="checkbox"/>	<input type="checkbox"/>	<input type="checkbox"/>	<input type="checkbox"/>
	Initial value	*	*	*	*	*	*	*	*
	Read/Write	R/W	R/W	R/W	R/W	R/W	R/W	R/W	R/W

*: Undefined
x = 0 to 15

MD10[1]—Message Data 10[1]	H'F900	HCAN0
MD10[2]—Message Data 10[2]	H'F901	HCAN0
MD10[3]—Message Data 10[3]	H'F902	HCAN0
MD10[4]—Message Data 10[4]	H'F903	HCAN0
MD10[5]—Message Data 10[5]	H'F904	HCAN0
MD10[6]—Message Data 10[6]	H'F905	HCAN0
MD10[7]—Message Data 10[7]	H'F906	HCAN0
MD10[8]—Message Data 10[8]	H'F907	HCAN0

MDx[1]	Bit	7	6	5	4	3	2	1	0
		<input type="checkbox"/>	<input type="checkbox"/>	<input type="checkbox"/>	<input type="checkbox"/>	<input type="checkbox"/>	<input type="checkbox"/>	<input type="checkbox"/>	<input type="checkbox"/>
	Initial value	*	*	*	*	*	*	*	*
	Read/Write	R/W	R/W	R/W	R/W	R/W	R/W	R/W	R/W
MDx[2]	Bit	7	6	5	4	3	2	1	0
		<input type="checkbox"/>	<input type="checkbox"/>	<input type="checkbox"/>	<input type="checkbox"/>	<input type="checkbox"/>	<input type="checkbox"/>	<input type="checkbox"/>	<input type="checkbox"/>
	Initial value	*	*	*	*	*	*	*	*
	Read/Write	R/W	R/W	R/W	R/W	R/W	R/W	R/W	R/W
MDx[3]	Bit	7	6	5	4	3	2	1	0
		<input type="checkbox"/>	<input type="checkbox"/>	<input type="checkbox"/>	<input type="checkbox"/>	<input type="checkbox"/>	<input type="checkbox"/>	<input type="checkbox"/>	<input type="checkbox"/>
	Initial value	*	*	*	*	*	*	*	*
	Read/Write	R/W	R/W	R/W	R/W	R/W	R/W	R/W	R/W
MDx[4]	Bit	7	6	5	4	3	2	1	0
		<input type="checkbox"/>	<input type="checkbox"/>	<input type="checkbox"/>	<input type="checkbox"/>	<input type="checkbox"/>	<input type="checkbox"/>	<input type="checkbox"/>	<input type="checkbox"/>
	Initial value	*	*	*	*	*	*	*	*
	Read/Write	R/W	R/W	R/W	R/W	R/W	R/W	R/W	R/W
MDx[5]	Bit	7	6	5	4	3	2	1	0
		<input type="checkbox"/>	<input type="checkbox"/>	<input type="checkbox"/>	<input type="checkbox"/>	<input type="checkbox"/>	<input type="checkbox"/>	<input type="checkbox"/>	<input type="checkbox"/>
	Initial value	*	*	*	*	*	*	*	*
	Read/Write	R/W	R/W	R/W	R/W	R/W	R/W	R/W	R/W
MDx[6]	Bit	7	6	5	4	3	2	1	0
		<input type="checkbox"/>	<input type="checkbox"/>	<input type="checkbox"/>	<input type="checkbox"/>	<input type="checkbox"/>	<input type="checkbox"/>	<input type="checkbox"/>	<input type="checkbox"/>
	Initial value	*	*	*	*	*	*	*	*
	Read/Write	R/W	R/W	R/W	R/W	R/W	R/W	R/W	R/W
MDx[7]	Bit	7	6	5	4	3	2	1	0
		<input type="checkbox"/>	<input type="checkbox"/>	<input type="checkbox"/>	<input type="checkbox"/>	<input type="checkbox"/>	<input type="checkbox"/>	<input type="checkbox"/>	<input type="checkbox"/>
	Initial value	*	*	*	*	*	*	*	*
	Read/Write	R/W	R/W	R/W	R/W	R/W	R/W	R/W	R/W
MDx[8]	Bit	7	6	5	4	3	2	1	0
		<input type="checkbox"/>	<input type="checkbox"/>	<input type="checkbox"/>	<input type="checkbox"/>	<input type="checkbox"/>	<input type="checkbox"/>	<input type="checkbox"/>	<input type="checkbox"/>
	Initial value	*	*	*	*	*	*	*	*
	Read/Write	R/W	R/W	R/W	R/W	R/W	R/W	R/W	R/W

*: Undefined
x = 0 to 15

MD11[1]—Message Data 11[1]	H'F908	HCAN0
MD11[2]—Message Data 11[2]	H'F909	HCAN0
MD11[3]—Message Data 11[3]	H'F90A	HCAN0
MD11[4]—Message Data 11[4]	H'F90B	HCAN0
MD11[5]—Message Data 11[5]	H'F90C	HCAN0
MD11[6]—Message Data 11[6]	H'F90D	HCAN0
MD11[7]—Message Data 11[7]	H'F90E	HCAN0
MD11[8]—Message Data 11[8]	H'F90F	HCAN0

MDx[1]	Bit	7	6	5	4	3	2	1	0
		<input type="checkbox"/>	<input type="checkbox"/>	<input type="checkbox"/>	<input type="checkbox"/>	<input type="checkbox"/>	<input type="checkbox"/>	<input type="checkbox"/>	<input type="checkbox"/>
	Initial value	*	*	*	*	*	*	*	*
	Read/Write	R/W	R/W	R/W	R/W	R/W	R/W	R/W	R/W
MDx[2]	Bit	7	6	5	4	3	2	1	0
		<input type="checkbox"/>	<input type="checkbox"/>	<input type="checkbox"/>	<input type="checkbox"/>	<input type="checkbox"/>	<input type="checkbox"/>	<input type="checkbox"/>	<input type="checkbox"/>
	Initial value	*	*	*	*	*	*	*	*
	Read/Write	R/W	R/W	R/W	R/W	R/W	R/W	R/W	R/W
MDx[3]	Bit	7	6	5	4	3	2	1	0
		<input type="checkbox"/>	<input type="checkbox"/>	<input type="checkbox"/>	<input type="checkbox"/>	<input type="checkbox"/>	<input type="checkbox"/>	<input type="checkbox"/>	<input type="checkbox"/>
	Initial value	*	*	*	*	*	*	*	*
	Read/Write	R/W	R/W	R/W	R/W	R/W	R/W	R/W	R/W
MDx[4]	Bit	7	6	5	4	3	2	1	0
		<input type="checkbox"/>	<input type="checkbox"/>	<input type="checkbox"/>	<input type="checkbox"/>	<input type="checkbox"/>	<input type="checkbox"/>	<input type="checkbox"/>	<input type="checkbox"/>
	Initial value	*	*	*	*	*	*	*	*
	Read/Write	R/W	R/W	R/W	R/W	R/W	R/W	R/W	R/W
MDx[5]	Bit	7	6	5	4	3	2	1	0
		<input type="checkbox"/>	<input type="checkbox"/>	<input type="checkbox"/>	<input type="checkbox"/>	<input type="checkbox"/>	<input type="checkbox"/>	<input type="checkbox"/>	<input type="checkbox"/>
	Initial value	*	*	*	*	*	*	*	*
	Read/Write	R/W	R/W	R/W	R/W	R/W	R/W	R/W	R/W
MDx[6]	Bit	7	6	5	4	3	2	1	0
		<input type="checkbox"/>	<input type="checkbox"/>	<input type="checkbox"/>	<input type="checkbox"/>	<input type="checkbox"/>	<input type="checkbox"/>	<input type="checkbox"/>	<input type="checkbox"/>
	Initial value	*	*	*	*	*	*	*	*
	Read/Write	R/W	R/W	R/W	R/W	R/W	R/W	R/W	R/W
MDx[7]	Bit	7	6	5	4	3	2	1	0
		<input type="checkbox"/>	<input type="checkbox"/>	<input type="checkbox"/>	<input type="checkbox"/>	<input type="checkbox"/>	<input type="checkbox"/>	<input type="checkbox"/>	<input type="checkbox"/>
	Initial value	*	*	*	*	*	*	*	*
	Read/Write	R/W	R/W	R/W	R/W	R/W	R/W	R/W	R/W
MDx[8]	Bit	7	6	5	4	3	2	1	0
		<input type="checkbox"/>	<input type="checkbox"/>	<input type="checkbox"/>	<input type="checkbox"/>	<input type="checkbox"/>	<input type="checkbox"/>	<input type="checkbox"/>	<input type="checkbox"/>
	Initial value	*	*	*	*	*	*	*	*
	Read/Write	R/W	R/W	R/W	R/W	R/W	R/W	R/W	R/W

*: Undefined
x = 0 to 15

MD12[1]—Message Data 12[1]	H'F910	HCAN0
MD12[2]—Message Data 12[2]	H'F911	HCAN0
MD12[3]—Message Data 12[3]	H'F912	HCAN0
MD12[4]—Message Data 12[4]	H'F913	HCAN0
MD12[5]—Message Data 12[5]	H'F914	HCAN0
MD12[6]—Message Data 12[6]	H'F915	HCAN0
MD12[7]—Message Data 12[7]	H'F916	HCAN0
MD12[8]—Message Data 12[8]	H'F917	HCAN0

MDx[1]	Bit	7	6	5	4	3	2	1	0
		<input type="checkbox"/>	<input type="checkbox"/>	<input type="checkbox"/>	<input type="checkbox"/>	<input type="checkbox"/>	<input type="checkbox"/>	<input type="checkbox"/>	<input type="checkbox"/>
	Initial value	*	*	*	*	*	*	*	*
	Read/Write	R/W	R/W	R/W	R/W	R/W	R/W	R/W	R/W
MDx[2]	Bit	7	6	5	4	3	2	1	0
		<input type="checkbox"/>	<input type="checkbox"/>	<input type="checkbox"/>	<input type="checkbox"/>	<input type="checkbox"/>	<input type="checkbox"/>	<input type="checkbox"/>	<input type="checkbox"/>
	Initial value	*	*	*	*	*	*	*	*
	Read/Write	R/W	R/W	R/W	R/W	R/W	R/W	R/W	R/W
MDx[3]	Bit	7	6	5	4	3	2	1	0
		<input type="checkbox"/>	<input type="checkbox"/>	<input type="checkbox"/>	<input type="checkbox"/>	<input type="checkbox"/>	<input type="checkbox"/>	<input type="checkbox"/>	<input type="checkbox"/>
	Initial value	*	*	*	*	*	*	*	*
	Read/Write	R/W	R/W	R/W	R/W	R/W	R/W	R/W	R/W
MDx[4]	Bit	7	6	5	4	3	2	1	0
		<input type="checkbox"/>	<input type="checkbox"/>	<input type="checkbox"/>	<input type="checkbox"/>	<input type="checkbox"/>	<input type="checkbox"/>	<input type="checkbox"/>	<input type="checkbox"/>
	Initial value	*	*	*	*	*	*	*	*
	Read/Write	R/W	R/W	R/W	R/W	R/W	R/W	R/W	R/W
MDx[5]	Bit	7	6	5	4	3	2	1	0
		<input type="checkbox"/>	<input type="checkbox"/>	<input type="checkbox"/>	<input type="checkbox"/>	<input type="checkbox"/>	<input type="checkbox"/>	<input type="checkbox"/>	<input type="checkbox"/>
	Initial value	*	*	*	*	*	*	*	*
	Read/Write	R/W	R/W	R/W	R/W	R/W	R/W	R/W	R/W
MDx[6]	Bit	7	6	5	4	3	2	1	0
		<input type="checkbox"/>	<input type="checkbox"/>	<input type="checkbox"/>	<input type="checkbox"/>	<input type="checkbox"/>	<input type="checkbox"/>	<input type="checkbox"/>	<input type="checkbox"/>
	Initial value	*	*	*	*	*	*	*	*
	Read/Write	R/W	R/W	R/W	R/W	R/W	R/W	R/W	R/W
MDx[7]	Bit	7	6	5	4	3	2	1	0
		<input type="checkbox"/>	<input type="checkbox"/>	<input type="checkbox"/>	<input type="checkbox"/>	<input type="checkbox"/>	<input type="checkbox"/>	<input type="checkbox"/>	<input type="checkbox"/>
	Initial value	*	*	*	*	*	*	*	*
	Read/Write	R/W	R/W	R/W	R/W	R/W	R/W	R/W	R/W
MDx[8]	Bit	7	6	5	4	3	2	1	0
		<input type="checkbox"/>	<input type="checkbox"/>	<input type="checkbox"/>	<input type="checkbox"/>	<input type="checkbox"/>	<input type="checkbox"/>	<input type="checkbox"/>	<input type="checkbox"/>
	Initial value	*	*	*	*	*	*	*	*
	Read/Write	R/W	R/W	R/W	R/W	R/W	R/W	R/W	R/W

*: Undefined
x = 0 to 15

MD13[1]—Message Data 13[1]	H'F918	HCAN0
MD13[2]—Message Data 13[2]	H'F919	HCAN0
MD13[3]—Message Data 13[3]	H'F91A	HCAN0
MD13[4]—Message Data 13[4]	H'F91B	HCAN0
MD13[5]—Message Data 13[5]	H'F91C	HCAN0
MD13[6]—Message Data 13[6]	H'F91D	HCAN0
MD13[7]—Message Data 13[7]	H'F91E	HCAN0
MD13[8]—Message Data 13[8]	H'F91F	HCAN0

MDx[1]	Bit	7	6	5	4	3	2	1	0
		<input type="checkbox"/>	<input type="checkbox"/>	<input type="checkbox"/>	<input type="checkbox"/>	<input type="checkbox"/>	<input type="checkbox"/>	<input type="checkbox"/>	<input type="checkbox"/>
	Initial value	*	*	*	*	*	*	*	*
	Read/Write	R/W	R/W	R/W	R/W	R/W	R/W	R/W	R/W
MDx[2]	Bit	7	6	5	4	3	2	1	0
		<input type="checkbox"/>	<input type="checkbox"/>	<input type="checkbox"/>	<input type="checkbox"/>	<input type="checkbox"/>	<input type="checkbox"/>	<input type="checkbox"/>	<input type="checkbox"/>
	Initial value	*	*	*	*	*	*	*	*
	Read/Write	R/W	R/W	R/W	R/W	R/W	R/W	R/W	R/W
MDx[3]	Bit	7	6	5	4	3	2	1	0
		<input type="checkbox"/>	<input type="checkbox"/>	<input type="checkbox"/>	<input type="checkbox"/>	<input type="checkbox"/>	<input type="checkbox"/>	<input type="checkbox"/>	<input type="checkbox"/>
	Initial value	*	*	*	*	*	*	*	*
	Read/Write	R/W	R/W	R/W	R/W	R/W	R/W	R/W	R/W
MDx[4]	Bit	7	6	5	4	3	2	1	0
		<input type="checkbox"/>	<input type="checkbox"/>	<input type="checkbox"/>	<input type="checkbox"/>	<input type="checkbox"/>	<input type="checkbox"/>	<input type="checkbox"/>	<input type="checkbox"/>
	Initial value	*	*	*	*	*	*	*	*
	Read/Write	R/W	R/W	R/W	R/W	R/W	R/W	R/W	R/W
MDx[5]	Bit	7	6	5	4	3	2	1	0
		<input type="checkbox"/>	<input type="checkbox"/>	<input type="checkbox"/>	<input type="checkbox"/>	<input type="checkbox"/>	<input type="checkbox"/>	<input type="checkbox"/>	<input type="checkbox"/>
	Initial value	*	*	*	*	*	*	*	*
	Read/Write	R/W	R/W	R/W	R/W	R/W	R/W	R/W	R/W
MDx[6]	Bit	7	6	5	4	3	2	1	0
		<input type="checkbox"/>	<input type="checkbox"/>	<input type="checkbox"/>	<input type="checkbox"/>	<input type="checkbox"/>	<input type="checkbox"/>	<input type="checkbox"/>	<input type="checkbox"/>
	Initial value	*	*	*	*	*	*	*	*
	Read/Write	R/W	R/W	R/W	R/W	R/W	R/W	R/W	R/W
MDx[7]	Bit	7	6	5	4	3	2	1	0
		<input type="checkbox"/>	<input type="checkbox"/>	<input type="checkbox"/>	<input type="checkbox"/>	<input type="checkbox"/>	<input type="checkbox"/>	<input type="checkbox"/>	<input type="checkbox"/>
	Initial value	*	*	*	*	*	*	*	*
	Read/Write	R/W	R/W	R/W	R/W	R/W	R/W	R/W	R/W
MDx[8]	Bit	7	6	5	4	3	2	1	0
		<input type="checkbox"/>	<input type="checkbox"/>	<input type="checkbox"/>	<input type="checkbox"/>	<input type="checkbox"/>	<input type="checkbox"/>	<input type="checkbox"/>	<input type="checkbox"/>
	Initial value	*	*	*	*	*	*	*	*
	Read/Write	R/W	R/W	R/W	R/W	R/W	R/W	R/W	R/W

*: Undefined
x = 0 to 15

MD14[1]—Message Data 14[1]	H'F920	HCAN0
MD14[2]—Message Data 14[2]	H'F921	HCAN0
MD14[3]—Message Data 14[3]	H'F922	HCAN0
MD14[4]—Message Data 14[4]	H'F923	HCAN0
MD14[5]—Message Data 14[5]	H'F924	HCAN0
MD14[6]—Message Data 14[6]	H'F925	HCAN0
MD14[7]—Message Data 14[7]	H'F926	HCAN0
MD14[8]—Message Data 14[8]	H'F927	HCAN0

MDx[1]	Bit	7	6	5	4	3	2	1	0
		<input type="checkbox"/>	<input type="checkbox"/>	<input type="checkbox"/>	<input type="checkbox"/>	<input type="checkbox"/>	<input type="checkbox"/>	<input type="checkbox"/>	<input type="checkbox"/>
	Initial value	*	*	*	*	*	*	*	*
	Read/Write	R/W	R/W	R/W	R/W	R/W	R/W	R/W	R/W
MDx[2]	Bit	7	6	5	4	3	2	1	0
		<input type="checkbox"/>	<input type="checkbox"/>	<input type="checkbox"/>	<input type="checkbox"/>	<input type="checkbox"/>	<input type="checkbox"/>	<input type="checkbox"/>	<input type="checkbox"/>
	Initial value	*	*	*	*	*	*	*	*
	Read/Write	R/W	R/W	R/W	R/W	R/W	R/W	R/W	R/W
MDx[3]	Bit	7	6	5	4	3	2	1	0
		<input type="checkbox"/>	<input type="checkbox"/>	<input type="checkbox"/>	<input type="checkbox"/>	<input type="checkbox"/>	<input type="checkbox"/>	<input type="checkbox"/>	<input type="checkbox"/>
	Initial value	*	*	*	*	*	*	*	*
	Read/Write	R/W	R/W	R/W	R/W	R/W	R/W	R/W	R/W
MDx[4]	Bit	7	6	5	4	3	2	1	0
		<input type="checkbox"/>	<input type="checkbox"/>	<input type="checkbox"/>	<input type="checkbox"/>	<input type="checkbox"/>	<input type="checkbox"/>	<input type="checkbox"/>	<input type="checkbox"/>
	Initial value	*	*	*	*	*	*	*	*
	Read/Write	R/W	R/W	R/W	R/W	R/W	R/W	R/W	R/W
MDx[5]	Bit	7	6	5	4	3	2	1	0
		<input type="checkbox"/>	<input type="checkbox"/>	<input type="checkbox"/>	<input type="checkbox"/>	<input type="checkbox"/>	<input type="checkbox"/>	<input type="checkbox"/>	<input type="checkbox"/>
	Initial value	*	*	*	*	*	*	*	*
	Read/Write	R/W	R/W	R/W	R/W	R/W	R/W	R/W	R/W
MDx[6]	Bit	7	6	5	4	3	2	1	0
		<input type="checkbox"/>	<input type="checkbox"/>	<input type="checkbox"/>	<input type="checkbox"/>	<input type="checkbox"/>	<input type="checkbox"/>	<input type="checkbox"/>	<input type="checkbox"/>
	Initial value	*	*	*	*	*	*	*	*
	Read/Write	R/W	R/W	R/W	R/W	R/W	R/W	R/W	R/W
MDx[7]	Bit	7	6	5	4	3	2	1	0
		<input type="checkbox"/>	<input type="checkbox"/>	<input type="checkbox"/>	<input type="checkbox"/>	<input type="checkbox"/>	<input type="checkbox"/>	<input type="checkbox"/>	<input type="checkbox"/>
	Initial value	*	*	*	*	*	*	*	*
	Read/Write	R/W	R/W	R/W	R/W	R/W	R/W	R/W	R/W
MDx[8]	Bit	7	6	5	4	3	2	1	0
		<input type="checkbox"/>	<input type="checkbox"/>	<input type="checkbox"/>	<input type="checkbox"/>	<input type="checkbox"/>	<input type="checkbox"/>	<input type="checkbox"/>	<input type="checkbox"/>
	Initial value	*	*	*	*	*	*	*	*
	Read/Write	R/W	R/W	R/W	R/W	R/W	R/W	R/W	R/W

*: Undefined
x = 0 to 15

MD15[1]—Message Data 15[1]	H'F928	HCAN0
MD15[2]—Message Data 15[2]	H'F929	HCAN0
MD15[3]—Message Data 15[3]	H'F92A	HCAN0
MD15[4]—Message Data 15[4]	H'F92B	HCAN0
MD15[5]—Message Data 15[5]	H'F92C	HCAN0
MD15[6]—Message Data 15[6]	H'F92D	HCAN0
MD15[7]—Message Data 15[7]	H'F92E	HCAN0
MD15[8]—Message Data 15[8]	H'F92F	HCAN0

MDx[1]	Bit	7	6	5	4	3	2	1	0
		<input type="checkbox"/>	<input type="checkbox"/>	<input type="checkbox"/>	<input type="checkbox"/>	<input type="checkbox"/>	<input type="checkbox"/>	<input type="checkbox"/>	<input type="checkbox"/>
	Initial value	*	*	*	*	*	*	*	*
	Read/Write	R/W	R/W	R/W	R/W	R/W	R/W	R/W	R/W
MDx[2]	Bit	7	6	5	4	3	2	1	0
		<input type="checkbox"/>	<input type="checkbox"/>	<input type="checkbox"/>	<input type="checkbox"/>	<input type="checkbox"/>	<input type="checkbox"/>	<input type="checkbox"/>	<input type="checkbox"/>
	Initial value	*	*	*	*	*	*	*	*
	Read/Write	R/W	R/W	R/W	R/W	R/W	R/W	R/W	R/W
MDx[3]	Bit	7	6	5	4	3	2	1	0
		<input type="checkbox"/>	<input type="checkbox"/>	<input type="checkbox"/>	<input type="checkbox"/>	<input type="checkbox"/>	<input type="checkbox"/>	<input type="checkbox"/>	<input type="checkbox"/>
	Initial value	*	*	*	*	*	*	*	*
	Read/Write	R/W	R/W	R/W	R/W	R/W	R/W	R/W	R/W
MDx[4]	Bit	7	6	5	4	3	2	1	0
		<input type="checkbox"/>	<input type="checkbox"/>	<input type="checkbox"/>	<input type="checkbox"/>	<input type="checkbox"/>	<input type="checkbox"/>	<input type="checkbox"/>	<input type="checkbox"/>
	Initial value	*	*	*	*	*	*	*	*
	Read/Write	R/W	R/W	R/W	R/W	R/W	R/W	R/W	R/W
MDx[5]	Bit	7	6	5	4	3	2	1	0
		<input type="checkbox"/>	<input type="checkbox"/>	<input type="checkbox"/>	<input type="checkbox"/>	<input type="checkbox"/>	<input type="checkbox"/>	<input type="checkbox"/>	<input type="checkbox"/>
	Initial value	*	*	*	*	*	*	*	*
	Read/Write	R/W	R/W	R/W	R/W	R/W	R/W	R/W	R/W
MDx[6]	Bit	7	6	5	4	3	2	1	0
		<input type="checkbox"/>	<input type="checkbox"/>	<input type="checkbox"/>	<input type="checkbox"/>	<input type="checkbox"/>	<input type="checkbox"/>	<input type="checkbox"/>	<input type="checkbox"/>
	Initial value	*	*	*	*	*	*	*	*
	Read/Write	R/W	R/W	R/W	R/W	R/W	R/W	R/W	R/W
MDx[7]	Bit	7	6	5	4	3	2	1	0
		<input type="checkbox"/>	<input type="checkbox"/>	<input type="checkbox"/>	<input type="checkbox"/>	<input type="checkbox"/>	<input type="checkbox"/>	<input type="checkbox"/>	<input type="checkbox"/>
	Initial value	*	*	*	*	*	*	*	*
	Read/Write	R/W	R/W	R/W	R/W	R/W	R/W	R/W	R/W
MDx[8]	Bit	7	6	5	4	3	2	1	0
		<input type="checkbox"/>	<input type="checkbox"/>	<input type="checkbox"/>	<input type="checkbox"/>	<input type="checkbox"/>	<input type="checkbox"/>	<input type="checkbox"/>	<input type="checkbox"/>
	Initial value	*	*	*	*	*	*	*	*
	Read/Write	R/W	R/W	R/W	R/W	R/W	R/W	R/W	R/W

*: Undefined
x = 0 to 15

MC0[1]—Message Control 0[1]	H'FA20	HCAN1
MC0[2]—Message Control 0[2]	H'FA21	HCAN1
MC0[3]—Message Control 0[3]	H'FA22	HCAN1
MC0[4]—Message Control 0[4]	H'FA23	HCAN1
MC0[5]—Message Control 0[5]	H'FA24	HCAN1
MC0[6]—Message Control 0[6]	H'FA25	HCAN1
MC0[7]—Message Control 0[7]	H'FA26	HCAN1
MC0[8]—Message Control 0[8]	H'FA27	HCAN1

Note: These registers are not available in the H8S/2635 and H8S/2634.

MC0[1]

Bit	7	6	5	4	3	2	1	0
	—	—	—	—	DLC3	DLC2	DLC1	DLC0
Initial value	Undefined	Undefined	Undefined	Undefined	Undefined	Undefined	Undefined	Undefined
Read/Write	R/W	R/W	R/W	R/W	R/W	R/W	R/W	R/W

Data Length Code

0	0	0	0	Data length = 0 bytes
		1		Data length = 1 byte
		1	0	Data length = 2 bytes
			1	Data length = 3 bytes
	1	0	0	Data length = 4 bytes
			1	Data length = 5 bytes
		1	0	Data length = 6 bytes
			1	Data length = 7 bytes
1	0/1	0/1	0/1	Data length = 8 bytes

MC0[2]

Bit	7	6	5	4	3	2	1	0
	—	—	—	—	—	—	—	—
Initial value	Undefined	Undefined	Undefined	Undefined	Undefined	Undefined	Undefined	Undefined
Read/Write	R/W	R/W	R/W	R/W	R/W	R/W	R/W	R/W

MC0[3]

Bit	7	6	5	4	3	2	1	0
	—	—	—	—	—	—	—	—
Initial value	Undefined	Undefined	Undefined	Undefined	Undefined	Undefined	Undefined	Undefined
Read/Write	R/W	R/W	R/W	R/W	R/W	R/W	R/W	R/W

MC0[4]

Bit	7	6	5	4	3	2	1	0
	—	—	—	—	—	—	—	—
Initial value	Undefined	Undefined	Undefined	Undefined	Undefined	Undefined	Undefined	Undefined
Read/Write	R/W	R/W	R/W	R/W	R/W	R/W	R/W	R/W

MC0[5]

Bit	7	6	5	4	3	2	1	0
	STD_ID2	STD_ID1	STD_ID0	RTR	IDE	—	EXD_ID17	EXD_ID16
Initial value	Undefined	Undefined	Undefined	Undefined	Undefined	Undefined	Undefined	Undefined
Read/Write	R/W	R/W	R/W	R/W	R/W	R/W	R/W	R/W

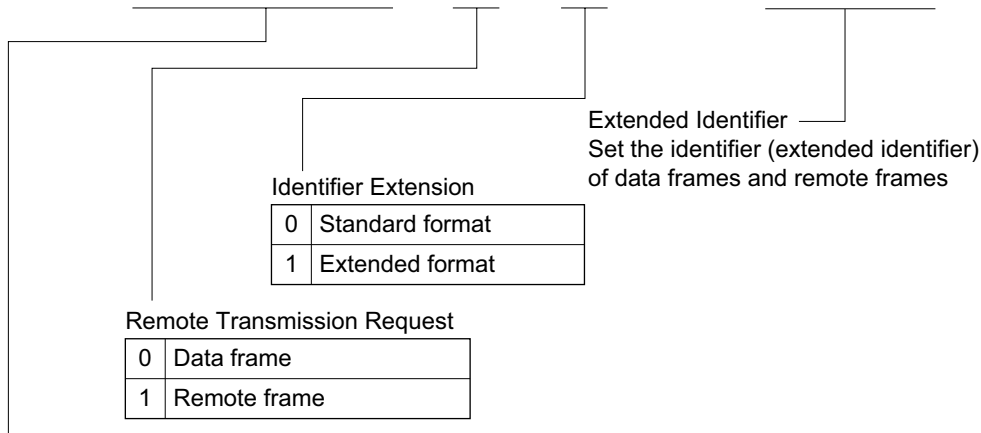

Identifier Extension

0	Standard format
1	Extended format

Remote Transmission Request

0	Data frame
1	Remote frame

Extended Identifier
Set the identifier (extended identifier) of data frames and remote frames

Standard Identifier
Set the identifier (standard identifier) of data frames and remote frames

MC0[6]

Bit	7	6	5	4	3	2	1	0
	STD_ID10	STD_ID9	STD_ID8	STD_ID7	STD_ID6	STD_ID5	STD_ID4	STD_ID3
Initial value	Undefined	Undefined	Undefined	Undefined	Undefined	Undefined	Undefined	Undefined
Read/Write	R/W	R/W	R/W	R/W	R/W	R/W	R/W	R/W

Standard Identifier
Set the identifier (standard identifier) of data frames and remote frames



MC0[7]

Bit	7	6	5	4	3	2	1	0
	EXD_ID7	EXD_ID6	EXD_ID5	EXD_ID4	EXD_ID3	EXD_ID2	EXD_ID1	EXD_ID0
Initial value	Undefined	Undefined	Undefined	Undefined	Undefined	Undefined	Undefined	Undefined
Read/Write	R/W	R/W	R/W	R/W	R/W	R/W	R/W	R/W

Extended Identifier 
 Set the identifier (extended identifier) of data frames and remote frames

MC0[8]

Bit	7	6	5	4	3	2	1	0
	EXD_ID15	EXD_ID14	EXD_ID13	EXD_ID12	EXD_ID11	EXD_ID10	EXD_ID9	EXD_ID8
Initial value	Undefined	Undefined	Undefined	Undefined	Undefined	Undefined	Undefined	Undefined
Read/Write	R/W	R/W	R/W	R/W	R/W	R/W	R/W	R/W

Extended Identifier 
 Set the identifier (extended identifier) of data frames and remote frames

MC1[1]—Message Control 1[1]	H'FA28	HCAN1
MC1[2]—Message Control 1[2]	H'FA29	HCAN1
MC1[3]—Message Control 1[3]	H'FA2A	HCAN1
MC1[4]—Message Control 1[4]	H'FA2B	HCAN1
MC1[5]—Message Control 1[5]	H'FA2C	HCAN1
MC1[6]—Message Control 1[6]	H'FA2D	HCAN1
MC1[7]—Message Control 1[7]	H'FA2E	HCAN1
MC1[8]—Message Control 1[8]	H'FA2F	HCAN1

Note: These registers are not available in the H8S/2635 and H8S/2634.

MC1[1]

Bit	7	6	5	4	3	2	1	0
	—	—	—	—	DLC3	DLC2	DLC1	DLC0
Initial value	Undefined	Undefined	Undefined	Undefined	Undefined	Undefined	Undefined	Undefined
Read/Write	R/W	R/W	R/W	R/W	R/W	R/W	R/W	R/W

Data Length Code

0	0	0	0	Data length = 0 bytes
		1		Data length = 1 byte
		1	0	Data length = 2 bytes
			1	Data length = 3 bytes
	1	0	0	Data length = 4 bytes
			1	Data length = 5 bytes
		1	0	Data length = 6 bytes
			1	Data length = 7 bytes
1	0/1	0/1	0/1	Data length = 8 bytes

MC1[2]

Bit	7	6	5	4	3	2	1	0
	—	—	—	—	—	—	—	—
Initial value	Undefined	Undefined	Undefined	Undefined	Undefined	Undefined	Undefined	Undefined
Read/Write	R/W	R/W	R/W	R/W	R/W	R/W	R/W	R/W

MC1[3]

Bit	7	6	5	4	3	2	1	0
	—	—	—	—	—	—	—	—
Initial value	Undefined	Undefined	Undefined	Undefined	Undefined	Undefined	Undefined	Undefined
Read/Write	R/W	R/W	R/W	R/W	R/W	R/W	R/W	R/W

MC1[4]

Bit	7	6	5	4	3	2	1	0
	—	—	—	—	—	—	—	—
Initial value	Undefined	Undefined	Undefined	Undefined	Undefined	Undefined	Undefined	Undefined
Read/Write	R/W	R/W	R/W	R/W	R/W	R/W	R/W	R/W

MC1[5]

Bit	7	6	5	4	3	2	1	0
	STD_ID2	STD_ID1	STD_ID0	RTR	IDE	—	EXD_ID17	EXD_ID16
Initial value	Undefined	Undefined	Undefined	Undefined	Undefined	Undefined	Undefined	Undefined
Read/Write	R/W	R/W	R/W	R/W	R/W	R/W	R/W	R/W

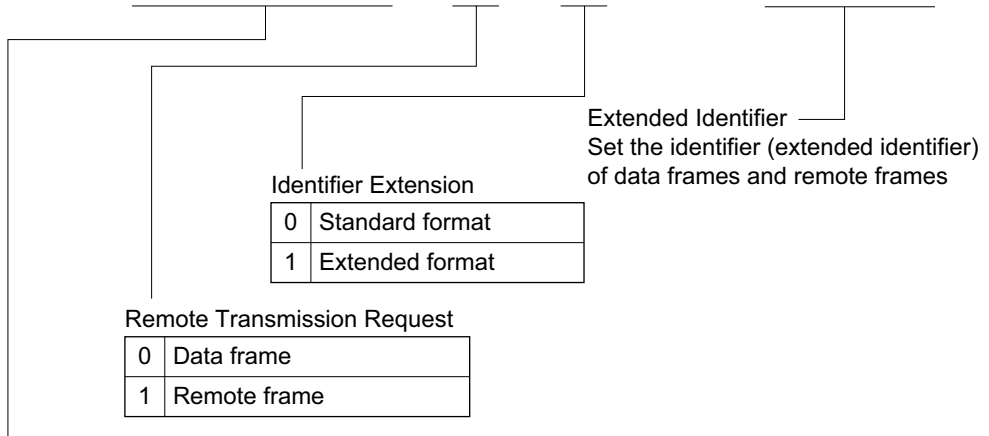

Identifier Extension

0	Standard format
1	Extended format

Remote Transmission Request

0	Data frame
1	Remote frame

Extended Identifier
Set the identifier (extended identifier) of data frames and remote frames

Standard Identifier

Set the identifier (standard identifier) of data frames and remote frames

MC1[6]

Bit	7	6	5	4	3	2	1	0
	STD_ID10	STD_ID9	STD_ID8	STD_ID7	STD_ID6	STD_ID5	STD_ID4	STD_ID3
Initial value	Undefined	Undefined	Undefined	Undefined	Undefined	Undefined	Undefined	Undefined
Read/Write	R/W	R/W	R/W	R/W	R/W	R/W	R/W	R/W

Standard Identifier
Set the identifier (standard identifier) of data frames and remote frames

MC1[7]

Bit	7	6	5	4	3	2	1	0
	EXD_ID7	EXD_ID6	EXD_ID5	EXD_ID4	EXD_ID3	EXD_ID2	EXD_ID1	EXD_ID0
Initial value	Undefined	Undefined	Undefined	Undefined	Undefined	Undefined	Undefined	Undefined
Read/Write	R/W	R/W	R/W	R/W	R/W	R/W	R/W	R/W

Extended Identifier _____

Set the identifier (extended identifier) of data frames and remote frames

MC1[8]

Bit	7	6	5	4	3	2	1	0
	EXD_ID15	EXD_ID14	EXD_ID13	EXD_ID12	EXD_ID11	EXD_ID10	EXD_ID9	EXD_ID8
Initial value	Undefined	Undefined	Undefined	Undefined	Undefined	Undefined	Undefined	Undefined
Read/Write	R/W	R/W	R/W	R/W	R/W	R/W	R/W	R/W

Extended Identifier _____

Set the identifier (extended identifier) of data frames and remote frames

MC2[1]—Message Control 2[1]	H'FA30	HCAN1
MC2[2]—Message Control 2[2]	H'FA31	HCAN1
MC2[3]—Message Control 2[3]	H'FA32	HCAN1
MC2[4]—Message Control 2[4]	H'FA33	HCAN1
MC2[5]—Message Control 2[5]	H'FA34	HCAN1
MC2[6]—Message Control 2[6]	H'FA35	HCAN1
MC2[7]—Message Control 2[7]	H'FA36	HCAN1
MC2[8]—Message Control 2[8]	H'FA37	HCAN1

Note: These registers are not available in the H8S/2635 and H8S/2634.

MC2[1]

Bit	7	6	5	4	3	2	1	0
	—	—	—	—	DLC3	DLC2	DLC1	DLC0
Initial value	Undefined	Undefined	Undefined	Undefined	Undefined	Undefined	Undefined	Undefined
Read/Write	R/W	R/W	R/W	R/W	R/W	R/W	R/W	R/W

Data Length Code

0	0	0	0	Data length = 0 bytes
		1	0	Data length = 1 byte
		1	0	Data length = 2 bytes
			1	Data length = 3 bytes
	1	0	0	Data length = 4 bytes
			1	Data length = 5 bytes
		1	0	Data length = 6 bytes
			1	Data length = 7 bytes
1	0/1	0/1	0/1	Data length = 8 bytes

MC2[2]

Bit	7	6	5	4	3	2	1	0
	—	—	—	—	—	—	—	—
Initial value	Undefined	Undefined	Undefined	Undefined	Undefined	Undefined	Undefined	Undefined
Read/Write	R/W	R/W	R/W	R/W	R/W	R/W	R/W	R/W

MC2[3]

Bit	7	6	5	4	3	2	1	0
	—	—	—	—	—	—	—	—
Initial value	Undefined	Undefined	Undefined	Undefined	Undefined	Undefined	Undefined	Undefined
Read/Write	R/W	R/W	R/W	R/W	R/W	R/W	R/W	R/W

MC2[4]

Bit	7	6	5	4	3	2	1	0
	—	—	—	—	—	—	—	—
Initial value	Undefined	Undefined	Undefined	Undefined	Undefined	Undefined	Undefined	Undefined
Read/Write	R/W	R/W	R/W	R/W	R/W	R/W	R/W	R/W

MC2[5]

Bit	7	6	5	4	3	2	1	0
	STD_ID2	STD_ID1	STD_ID0	RTR	IDE	—	EXD_ID17	EXD_ID16
Initial value	Undefined	Undefined	Undefined	Undefined	Undefined	Undefined	Undefined	Undefined
Read/Write	R/W	R/W	R/W	R/W	R/W	R/W	R/W	R/W

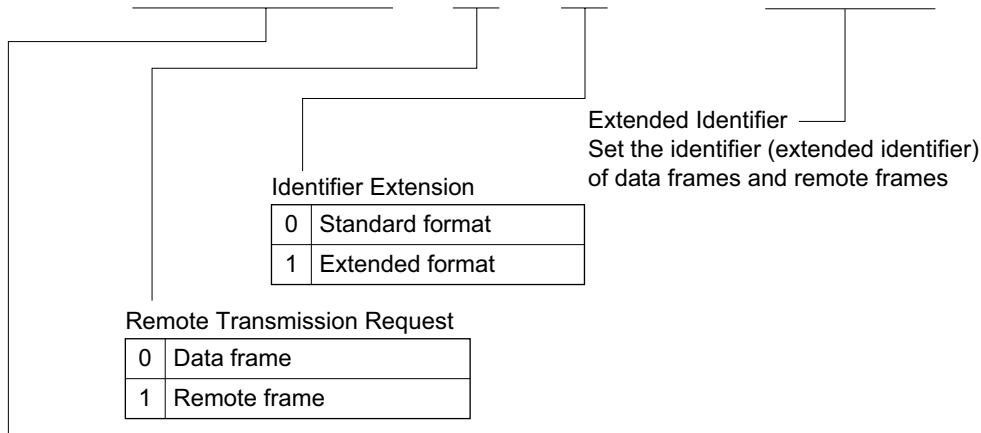

Identifier Extension

0	Standard format
1	Extended format

Remote Transmission Request

0	Data frame
1	Remote frame

Standard Identifier
Set the identifier (standard identifier) of data frames and remote frames

MC2[6]

Bit	7	6	5	4	3	2	1	0
	STD_ID10	STD_ID9	STD_ID8	STD_ID7	STD_ID6	STD_ID5	STD_ID4	STD_ID3
Initial value	Undefined	Undefined	Undefined	Undefined	Undefined	Undefined	Undefined	Undefined
Read/Write	R/W	R/W	R/W	R/W	R/W	R/W	R/W	R/W

Standard Identifier
Set the identifier (standard identifier) of data frames and remote frames



MC2[7]

Bit	7	6	5	4	3	2	1	0
	EXD_ID7	EXD_ID6	EXD_ID5	EXD_ID4	EXD_ID3	EXD_ID2	EXD_ID1	EXD_ID0
Initial value	Undefined	Undefined	Undefined	Undefined	Undefined	Undefined	Undefined	Undefined
Read/Write	R/W	R/W	R/W	R/W	R/W	R/W	R/W	R/W

Extended Identifier

Set the identifier (extended identifier) of data frames and remote frames

MC2[8]

Bit	7	6	5	4	3	2	1	0
	EXD_ID15	EXD_ID14	EXD_ID13	EXD_ID12	EXD_ID11	EXD_ID10	EXD_ID9	EXD_ID8
Initial value	Undefined	Undefined	Undefined	Undefined	Undefined	Undefined	Undefined	Undefined
Read/Write	R/W	R/W	R/W	R/W	R/W	R/W	R/W	R/W

Extended Identifier

Set the identifier (extended identifier) of data frames and remote frames

MC3[1]—Message Control 3[1]	H'FA38	HCAN1
MC3[2]—Message Control 3[2]	H'FA39	HCAN1
MC3[3]—Message Control 3[3]	H'FA3A	HCAN1
MC3[4]—Message Control 3[4]	H'FA3B	HCAN1
MC3[5]—Message Control 3[5]	H'FA3C	HCAN1
MC3[6]—Message Control 3[6]	H'FA3D	HCAN1
MC3[7]—Message Control 3[7]	H'FA3E	HCAN1
MC3[8]—Message Control 3[8]	H'FA3F	HCAN1

Note: These registers are not available in the H8S/2635 and H8S/2634.

MC3[1]

Bit	7	6	5	4	3	2	1	0
	—	—	—	—	DLC3	DLC2	DLC1	DLC0
Initial value	Undefined	Undefined	Undefined	Undefined	Undefined	Undefined	Undefined	Undefined
Read/Write	R/W	R/W	R/W	R/W	R/W	R/W	R/W	R/W

Data Length Code

0	0	0	0	Data length = 0 bytes
		1		Data length = 1 byte
		1	0	Data length = 2 bytes
			1	Data length = 3 bytes
	1	0	0	Data length = 4 bytes
			1	Data length = 5 bytes
		1	0	Data length = 6 bytes
			1	Data length = 7 bytes
1	0/1	0/1	0/1	Data length = 8 bytes

MC3[2]

Bit	7	6	5	4	3	2	1	0
	—	—	—	—	—	—	—	—
Initial value	Undefined	Undefined	Undefined	Undefined	Undefined	Undefined	Undefined	Undefined
Read/Write	R/W	R/W	R/W	R/W	R/W	R/W	R/W	R/W

MC3[3]

Bit	7	6	5	4	3	2	1	0
	—	—	—	—	—	—	—	—
Initial value	Undefined	Undefined	Undefined	Undefined	Undefined	Undefined	Undefined	Undefined
Read/Write	R/W	R/W	R/W	R/W	R/W	R/W	R/W	R/W

MC3[4]

Bit	7	6	5	4	3	2	1	0
	—	—	—	—	—	—	—	—
Initial value	Undefined	Undefined	Undefined	Undefined	Undefined	Undefined	Undefined	Undefined
Read/Write	R/W	R/W	R/W	R/W	R/W	R/W	R/W	R/W

MC3[5]

Bit	7	6	5	4	3	2	1	0
	STD_ID2	STD_ID1	STD_ID0	RTR	IDE	—	EXD_ID17	EXD_ID16
Initial value	Undefined	Undefined	Undefined	Undefined	Undefined	Undefined	Undefined	Undefined
Read/Write	R/W	R/W	R/W	R/W	R/W	R/W	R/W	R/W

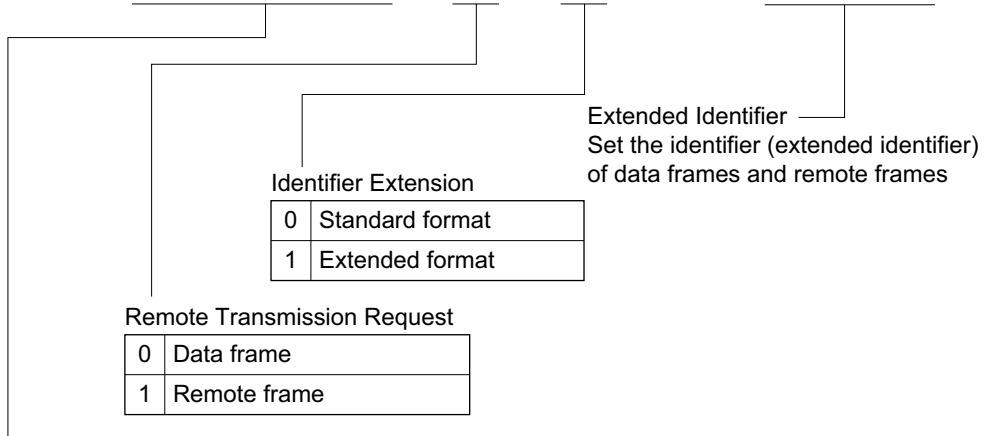

Identifier Extension

0	Standard format
1	Extended format

Remote Transmission Request

0	Data frame
1	Remote frame

Extended Identifier
Set the identifier (extended identifier) of data frames and remote frames

Standard Identifier

Set the identifier (standard identifier) of data frames and remote frames

MC3[6]

Bit	7	6	5	4	3	2	1	0
	STD_ID10	STD_ID9	STD_ID8	STD_ID7	STD_ID6	STD_ID5	STD_ID4	STD_ID3
Initial value	Undefined	Undefined	Undefined	Undefined	Undefined	Undefined	Undefined	Undefined
Read/Write	R/W	R/W	R/W	R/W	R/W	R/W	R/W	R/W

Standard Identifier
Set the identifier (standard identifier) of data frames and remote frames

MC3[7]

Bit	7	6	5	4	3	2	1	0
	EXD_ID7	EXD_ID6	EXD_ID5	EXD_ID4	EXD_ID3	EXD_ID2	EXD_ID1	EXD_ID0
Initial value	Undefined	Undefined	Undefined	Undefined	Undefined	Undefined	Undefined	Undefined
Read/Write	R/W	R/W	R/W	R/W	R/W	R/W	R/W	R/W

Extended Identifier _____

Set the identifier (extended identifier) of data frames and remote frames

MC3[8]

Bit	7	6	5	4	3	2	1	0
	EXD_ID15	EXD_ID14	EXD_ID13	EXD_ID12	EXD_ID11	EXD_ID10	EXD_ID9	EXD_ID8
Initial value	Undefined	Undefined	Undefined	Undefined	Undefined	Undefined	Undefined	Undefined
Read/Write	R/W	R/W	R/W	R/W	R/W	R/W	R/W	R/W

Extended Identifier _____

Set the identifier (extended identifier) of data frames and remote frames

MC4[1]—Message Control 4[1]	H'FA40	HCAN1
MC4[2]—Message Control 4[2]	H'FA41	HCAN1
MC4[3]—Message Control 4[3]	H'FA42	HCAN1
MC4[4]—Message Control 4[4]	H'FA43	HCAN1
MC4[5]—Message Control 4[5]	H'FA44	HCAN1
MC4[6]—Message Control 4[6]	H'FA45	HCAN1
MC4[7]—Message Control 4[7]	H'FA46	HCAN1
MC4[8]—Message Control 4[8]	H'FA47	HCAN1

Note: These registers are not available in the H8S/2635 and H8S/2634.

MC4[1]

Bit	7	6	5	4	3	2	1	0
	—	—	—	—	DLC3	DLC2	DLC1	DLC0
Initial value	Undefined	Undefined	Undefined	Undefined	Undefined	Undefined	Undefined	Undefined
Read/Write	R/W	R/W	R/W	R/W	R/W	R/W	R/W	R/W

Data Length Code

0	0	0	0	Data length = 0 bytes
		1	0	Data length = 1 byte
		1	0	Data length = 2 bytes
			1	Data length = 3 bytes
	1	0	0	Data length = 4 bytes
			1	Data length = 5 bytes
		1	0	Data length = 6 bytes
			1	Data length = 7 bytes
1	0/1	0/1	0/1	Data length = 8 bytes

MC4[2]

Bit	7	6	5	4	3	2	1	0
	—	—	—	—	—	—	—	—
Initial value	Undefined	Undefined	Undefined	Undefined	Undefined	Undefined	Undefined	Undefined
Read/Write	R/W	R/W	R/W	R/W	R/W	R/W	R/W	R/W

MC4[3]

Bit	7	6	5	4	3	2	1	0
	—	—	—	—	—	—	—	—
Initial value	Undefined	Undefined	Undefined	Undefined	Undefined	Undefined	Undefined	Undefined
Read/Write	R/W	R/W	R/W	R/W	R/W	R/W	R/W	R/W

MC4[4]

Bit	7	6	5	4	3	2	1	0
	—	—	—	—	—	—	—	—
Initial value	Undefined	Undefined	Undefined	Undefined	Undefined	Undefined	Undefined	Undefined
Read/Write	R/W	R/W	R/W	R/W	R/W	R/W	R/W	R/W

MC4[5]

Bit	7	6	5	4	3	2	1	0
	STD_ID2	STD_ID1	STD_ID0	RTR	IDE	—	EXD_ID17	EXD_ID16
Initial value	Undefined	Undefined	Undefined	Undefined	Undefined	Undefined	Undefined	Undefined
Read/Write	R/W	R/W	R/W	R/W	R/W	R/W	R/W	R/W

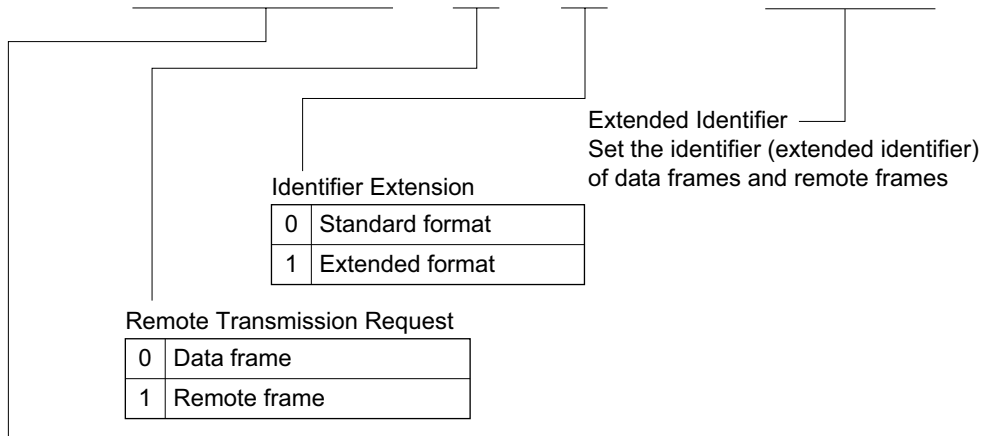

Standard Identifier

Set the identifier (standard identifier) of data frames and remote frames

MC4[6]

Bit	7	6	5	4	3	2	1	0
	STD_ID10	STD_ID9	STD_ID8	STD_ID7	STD_ID6	STD_ID5	STD_ID4	STD_ID3
Initial value	Undefined	Undefined	Undefined	Undefined	Undefined	Undefined	Undefined	Undefined
Read/Write	R/W	R/W	R/W	R/W	R/W	R/W	R/W	R/W

Standard Identifier —
Set the identifier (standard identifier) of data frames and remote frames

MC4[7]

Bit	7	6	5	4	3	2	1	0
	EXD_ID7	EXD_ID6	EXD_ID5	EXD_ID4	EXD_ID3	EXD_ID2	EXD_ID1	EXD_ID0
Initial value	Undefined	Undefined	Undefined	Undefined	Undefined	Undefined	Undefined	Undefined
Read/Write	R/W	R/W	R/W	R/W	R/W	R/W	R/W	R/W

Extended Identifier

Set the identifier (extended identifier) of data frames and remote frames

MC4[8]

Bit	7	6	5	4	3	2	1	0
	EXD_ID15	EXD_ID14	EXD_ID13	EXD_ID12	EXD_ID11	EXD_ID10	EXD_ID9	EXD_ID8
Initial value	Undefined	Undefined	Undefined	Undefined	Undefined	Undefined	Undefined	Undefined
Read/Write	R/W	R/W	R/W	R/W	R/W	R/W	R/W	R/W

Extended Identifier

Set the identifier (extended identifier) of data frames and remote frames

MC5[1]—Message Control 5[1]	H'FA48	HCAN1
MC5[2]—Message Control 5[2]	H'FA49	HCAN1
MC5[3]—Message Control 5[3]	H'FA4A	HCAN1
MC5[4]—Message Control 5[4]	H'FA4B	HCAN1
MC5[5]—Message Control 5[5]	H'FA4C	HCAN1
MC5[6]—Message Control 5[6]	H'FA4D	HCAN1
MC5[7]—Message Control 5[7]	H'FA4E	HCAN1
MC5[8]—Message Control 5[8]	H'FA4F	HCAN1

Note: These registers are not available in the H8S/2635 and H8S/2634.

MC5[1]

Bit	7	6	5	4	3	2	1	0
	—	—	—	—	DLC3	DLC2	DLC1	DLC0
Initial value	Undefined	Undefined	Undefined	Undefined	Undefined	Undefined	Undefined	Undefined
Read/Write	R/W	R/W	R/W	R/W	R/W	R/W	R/W	R/W

Data Length Code

0	0	0	0	Data length = 0 bytes
		1		Data length = 1 byte
		1	0	Data length = 2 bytes
			1	Data length = 3 bytes
	1	0	0	Data length = 4 bytes
			1	Data length = 5 bytes
		1	0	Data length = 6 bytes
			1	Data length = 7 bytes
1	0/1	0/1	0/1	Data length = 8 bytes

MC5[2]

Bit	7	6	5	4	3	2	1	0
	—	—	—	—	—	—	—	—
Initial value	Undefined	Undefined	Undefined	Undefined	Undefined	Undefined	Undefined	Undefined
Read/Write	R/W	R/W	R/W	R/W	R/W	R/W	R/W	R/W

MC5[3]

Bit	7	6	5	4	3	2	1	0
	—	—	—	—	—	—	—	—
Initial value	Undefined	Undefined	Undefined	Undefined	Undefined	Undefined	Undefined	Undefined
Read/Write	R/W	R/W	R/W	R/W	R/W	R/W	R/W	R/W

MC5[4]

Bit	7	6	5	4	3	2	1	0
	—	—	—	—	—	—	—	—
Initial value	Undefined	Undefined	Undefined	Undefined	Undefined	Undefined	Undefined	Undefined
Read/Write	R/W	R/W	R/W	R/W	R/W	R/W	R/W	R/W

MC5[5]

Bit	7	6	5	4	3	2	1	0
	STD_ID2	STD_ID1	STD_ID0	RTR	IDE	—	EXD_ID17	EXD_ID16
Initial value	Undefined	Undefined	Undefined	Undefined	Undefined	Undefined	Undefined	Undefined
Read/Write	R/W	R/W	R/W	R/W	R/W	R/W	R/W	R/W

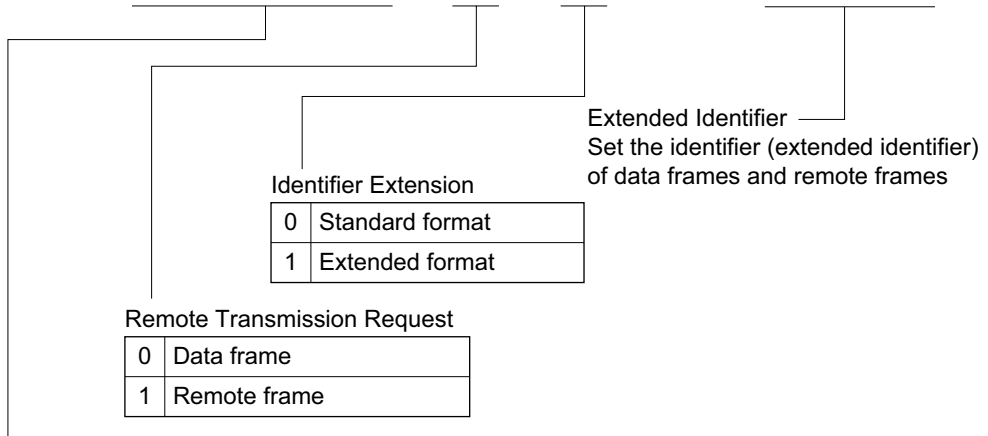

Standard Identifier

Set the identifier (standard identifier) of data frames and remote frames

MC5[6]

Bit	7	6	5	4	3	2	1	0
	STD_ID10	STD_ID9	STD_ID8	STD_ID7	STD_ID6	STD_ID5	STD_ID4	STD_ID3
Initial value	Undefined	Undefined	Undefined	Undefined	Undefined	Undefined	Undefined	Undefined
Read/Write	R/W	R/W	R/W	R/W	R/W	R/W	R/W	R/W

Standard Identifier
Set the identifier (standard identifier) of data frames and remote frames

MC5[7]

Bit	7	6	5	4	3	2	1	0
	EXD_ID7	EXD_ID6	EXD_ID5	EXD_ID4	EXD_ID3	EXD_ID2	EXD_ID1	EXD_ID0
Initial value	Undefined	Undefined	Undefined	Undefined	Undefined	Undefined	Undefined	Undefined
Read/Write	R/W	R/W	R/W	R/W	R/W	R/W	R/W	R/W

Extended Identifier _____

Set the identifier (extended identifier) of data frames and remote frames

MC5[8]

Bit	7	6	5	4	3	2	1	0
	EXD_ID15	EXD_ID14	EXD_ID13	EXD_ID12	EXD_ID11	EXD_ID10	EXD_ID9	EXD_ID8
Initial value	Undefined	Undefined	Undefined	Undefined	Undefined	Undefined	Undefined	Undefined
Read/Write	R/W	R/W	R/W	R/W	R/W	R/W	R/W	R/W

Extended Identifier _____

Set the identifier (extended identifier) of data frames and remote frames

MC6[1]—Message Control 6[1]	H'FA50	HCAN1
MC6[2]—Message Control 6[2]	H'FA51	HCAN1
MC6[3]—Message Control 6[3]	H'FA52	HCAN1
MC6[4]—Message Control 6[4]	H'FA53	HCAN1
MC6[5]—Message Control 6[5]	H'FA54	HCAN1
MC6[6]—Message Control 6[6]	H'FA55	HCAN1
MC6[7]—Message Control 6[7]	H'FA56	HCAN1
MC6[8]—Message Control 6[8]	H'FA57	HCAN1

Note: These registers are not available in the H8S/2635 and H8S/2634.

MC6[1]

Bit	7	6	5	4	3	2	1	0
	—	—	—	—	DLC3	DLC2	DLC1	DLC0
Initial value	Undefined	Undefined	Undefined	Undefined	Undefined	Undefined	Undefined	Undefined
Read/Write	R/W	R/W	R/W	R/W	R/W	R/W	R/W	R/W

Data Length Code

0	0	0	0	Data length = 0 bytes
		1	0	Data length = 1 byte
		1	0	Data length = 2 bytes
			1	Data length = 3 bytes
	1	0	0	Data length = 4 bytes
			1	Data length = 5 bytes
		1	0	Data length = 6 bytes
			1	Data length = 7 bytes
1	0/1	0/1	0/1	Data length = 8 bytes

MC6[2]

Bit	7	6	5	4	3	2	1	0
	—	—	—	—	—	—	—	—
Initial value	Undefined	Undefined	Undefined	Undefined	Undefined	Undefined	Undefined	Undefined
Read/Write	R/W	R/W	R/W	R/W	R/W	R/W	R/W	R/W

MC6[3]

Bit	7	6	5	4	3	2	1	0
	—	—	—	—	—	—	—	—
Initial value	Undefined	Undefined	Undefined	Undefined	Undefined	Undefined	Undefined	Undefined
Read/Write	R/W	R/W	R/W	R/W	R/W	R/W	R/W	R/W

MC6[4]

Bit	7	6	5	4	3	2	1	0
	—	—	—	—	—	—	—	—
Initial value	Undefined	Undefined	Undefined	Undefined	Undefined	Undefined	Undefined	Undefined
Read/Write	R/W	R/W	R/W	R/W	R/W	R/W	R/W	R/W

MC6[5]

Bit	7	6	5	4	3	2	1	0
	STD_ID2	STD_ID1	STD_ID0	RTR	IDE	—	EXD_ID17	EXD_ID16
Initial value	Undefined	Undefined	Undefined	Undefined	Undefined	Undefined	Undefined	Undefined
Read/Write	R/W	R/W	R/W	R/W	R/W	R/W	R/W	R/W

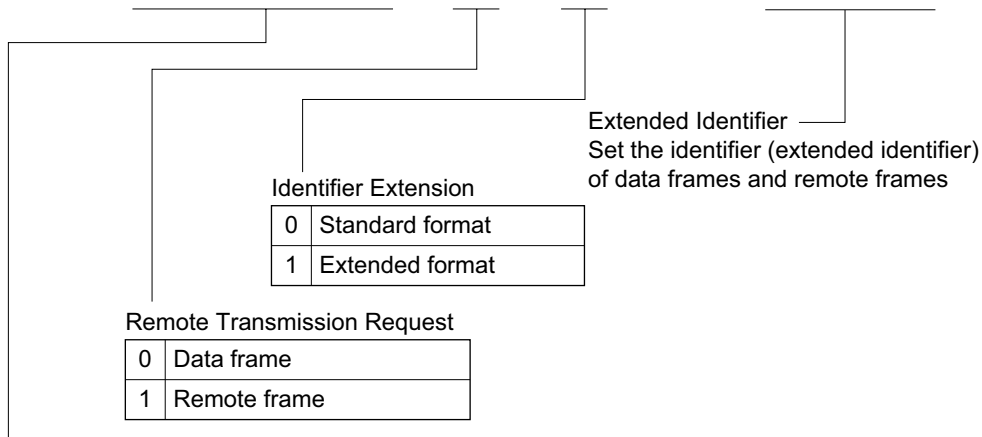

Identifier Extension

0	Standard format
1	Extended format

Remote Transmission Request

0	Data frame
1	Remote frame

Extended Identifier
Set the identifier (extended identifier) of data frames and remote frames

Standard Identifier
Set the identifier (standard identifier) of data frames and remote frames

MC6[6]

Bit	7	6	5	4	3	2	1	0
	STD_ID10	STD_ID9	STD_ID8	STD_ID7	STD_ID6	STD_ID5	STD_ID4	STD_ID3
Initial value	Undefined	Undefined	Undefined	Undefined	Undefined	Undefined	Undefined	Undefined
Read/Write	R/W	R/W	R/W	R/W	R/W	R/W	R/W	R/W

Standard Identifier
Set the identifier (standard identifier) of data frames and remote frames

MC6[7]

Bit	7	6	5	4	3	2	1	0
	EXD_ID7	EXD_ID6	EXD_ID5	EXD_ID4	EXD_ID3	EXD_ID2	EXD_ID1	EXD_ID0
Initial value	Undefined	Undefined	Undefined	Undefined	Undefined	Undefined	Undefined	Undefined
Read/Write	R/W	R/W	R/W	R/W	R/W	R/W	R/W	R/W

Extended Identifier

Set the identifier (extended identifier) of data frames and remote frames

MC6[8]

Bit	7	6	5	4	3	2	1	0
	EXD_ID15	EXD_ID14	EXD_ID13	EXD_ID12	EXD_ID11	EXD_ID10	EXD_ID9	EXD_ID8
Initial value	Undefined	Undefined	Undefined	Undefined	Undefined	Undefined	Undefined	Undefined
Read/Write	R/W	R/W	R/W	R/W	R/W	R/W	R/W	R/W

Extended Identifier

Set the identifier (extended identifier) of data frames and remote frames

MC7[1]—Message Control 7[1]	H'FA58	HCAN1
MC7[2]—Message Control 7[2]	H'FA59	HCAN1
MC7[3]—Message Control 7[3]	H'FA5A	HCAN1
MC7[4]—Message Control 7[4]	H'FA5B	HCAN1
MC7[5]—Message Control 7[5]	H'FA5C	HCAN1
MC7[6]—Message Control 7[6]	H'FA5D	HCAN1
MC7[7]—Message Control 7[7]	H'FA5E	HCAN1
MC7[8]—Message Control 7[8]	H'FA5F	HCAN1

Note: These registers are not available in the H8S/2635 and H8S/2634.

MC7[1]

Bit	7	6	5	4	3	2	1	0
	—	—	—	—	DLC3	DLC2	DLC1	DLC0
Initial value	Undefined	Undefined	Undefined	Undefined	Undefined	Undefined	Undefined	Undefined
Read/Write	R/W	R/W	R/W	R/W	R/W	R/W	R/W	R/W

Data Length Code

0	0	0	0	Data length = 0 bytes
		1		Data length = 1 byte
		1	0	Data length = 2 bytes
			1	Data length = 3 bytes
	1	0	0	Data length = 4 bytes
			1	Data length = 5 bytes
		1	0	Data length = 6 bytes
			1	Data length = 7 bytes
1	0/1	0/1	0/1	Data length = 8 bytes

MC7[2]

Bit	7	6	5	4	3	2	1	0
	—	—	—	—	—	—	—	—
Initial value	Undefined	Undefined	Undefined	Undefined	Undefined	Undefined	Undefined	Undefined
Read/Write	R/W	R/W	R/W	R/W	R/W	R/W	R/W	R/W

MC7[3]

Bit	7	6	5	4	3	2	1	0
	—	—	—	—	—	—	—	—
Initial value	Undefined	Undefined	Undefined	Undefined	Undefined	Undefined	Undefined	Undefined
Read/Write	R/W	R/W	R/W	R/W	R/W	R/W	R/W	R/W

MC7[4]

Bit	7	6	5	4	3	2	1	0
	—	—	—	—	—	—	—	—
Initial value	Undefined	Undefined	Undefined	Undefined	Undefined	Undefined	Undefined	Undefined
Read/Write	R/W	R/W	R/W	R/W	R/W	R/W	R/W	R/W

MC7[5]

Bit	7	6	5	4	3	2	1	0
	STD_ID2	STD_ID1	STD_ID0	RTR	IDE	—	EXD_ID17	EXD_ID16
Initial value	Undefined	Undefined	Undefined	Undefined	Undefined	Undefined	Undefined	Undefined
Read/Write	R/W	R/W	R/W	R/W	R/W	R/W	R/W	R/W

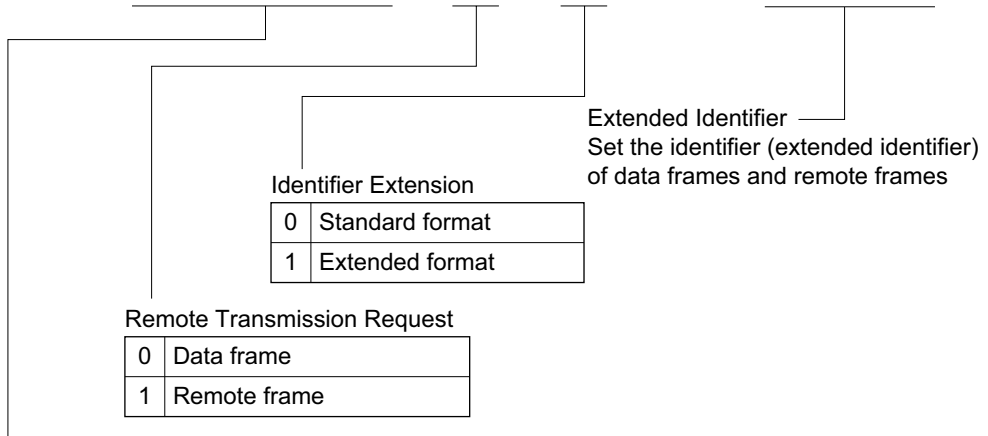

Standard Identifier

Set the identifier (standard identifier) of data frames and remote frames

MC7[6]

Bit	7	6	5	4	3	2	1	0
	STD_ID10	STD_ID9	STD_ID8	STD_ID7	STD_ID6	STD_ID5	STD_ID4	STD_ID3
Initial value	Undefined	Undefined	Undefined	Undefined	Undefined	Undefined	Undefined	Undefined
Read/Write	R/W	R/W	R/W	R/W	R/W	R/W	R/W	R/W

Standard Identifier
Set the identifier (standard identifier) of data frames and remote frames

MC7[7]

Bit	7	6	5	4	3	2	1	0
	EXD_ID7	EXD_ID6	EXD_ID5	EXD_ID4	EXD_ID3	EXD_ID2	EXD_ID1	EXD_ID0
Initial value	Undefined	Undefined	Undefined	Undefined	Undefined	Undefined	Undefined	Undefined
Read/Write	R/W	R/W	R/W	R/W	R/W	R/W	R/W	R/W

Extended Identifier

Set the identifier (extended identifier) of data frames and remote frames

MC7[8]

Bit	7	6	5	4	3	2	1	0
	EXD_ID15	EXD_ID14	EXD_ID13	EXD_ID12	EXD_ID11	EXD_ID10	EXD_ID9	EXD_ID8
Initial value	Undefined	Undefined	Undefined	Undefined	Undefined	Undefined	Undefined	Undefined
Read/Write	R/W	R/W	R/W	R/W	R/W	R/W	R/W	R/W

Extended Identifier

Set the identifier (extended identifier) of data frames and remote frames

MC8[1]—Message Control 8[1]	H'FA60	HCAN1
MC8[2]—Message Control 8[2]	H'FA61	HCAN1
MC8[3]—Message Control 8[3]	H'FA62	HCAN1
MC8[4]—Message Control 8[4]	H'FA63	HCAN1
MC8[5]—Message Control 8[5]	H'FA64	HCAN1
MC8[6]—Message Control 8[6]	H'FA65	HCAN1
MC8[7]—Message Control 8[7]	H'FA66	HCAN1
MC8[8]—Message Control 8[8]	H'FA67	HCAN1

Note: These registers are not available in the H8S/2635 and H8S/2634.

MC8[1]

Bit	7	6	5	4	3	2	1	0
	—	—	—	—	DLC3	DLC2	DLC1	DLC0
Initial value	Undefined	Undefined	Undefined	Undefined	Undefined	Undefined	Undefined	Undefined
Read/Write	R/W	R/W	R/W	R/W	R/W	R/W	R/W	R/W

Data Length Code

0	0	0	0	Data length = 0 bytes	
		1	0	Data length = 1 byte	
		1	0	0	Data length = 2 bytes
			1	0	Data length = 3 bytes
	1	0	0	0	Data length = 4 bytes
			1	0	Data length = 5 bytes
		1	0	0	Data length = 6 bytes
			1	0	Data length = 7 bytes
1	0/1	0/1	0/1	Data length = 8 bytes	

MC8[2]

Bit	7	6	5	4	3	2	1	0
	—	—	—	—	—	—	—	—
Initial value	Undefined	Undefined	Undefined	Undefined	Undefined	Undefined	Undefined	Undefined
Read/Write	R/W	R/W	R/W	R/W	R/W	R/W	R/W	R/W

MC8[3]

Bit	7	6	5	4	3	2	1	0
	—	—	—	—	—	—	—	—
Initial value	Undefined	Undefined	Undefined	Undefined	Undefined	Undefined	Undefined	Undefined
Read/Write	R/W	R/W	R/W	R/W	R/W	R/W	R/W	R/W

MC8[4]

Bit	7	6	5	4	3	2	1	0
	—	—	—	—	—	—	—	—
Initial value	Undefined	Undefined	Undefined	Undefined	Undefined	Undefined	Undefined	Undefined
Read/Write	R/W	R/W	R/W	R/W	R/W	R/W	R/W	R/W

MC8[5]

Bit	7	6	5	4	3	2	1	0
	STD_ID2	STD_ID1	STD_ID0	RTR	IDE	—	EXD_ID17	EXD_ID16
Initial value	Undefined	Undefined	Undefined	Undefined	Undefined	Undefined	Undefined	Undefined
Read/Write	R/W	R/W	R/W	R/W	R/W	R/W	R/W	R/W

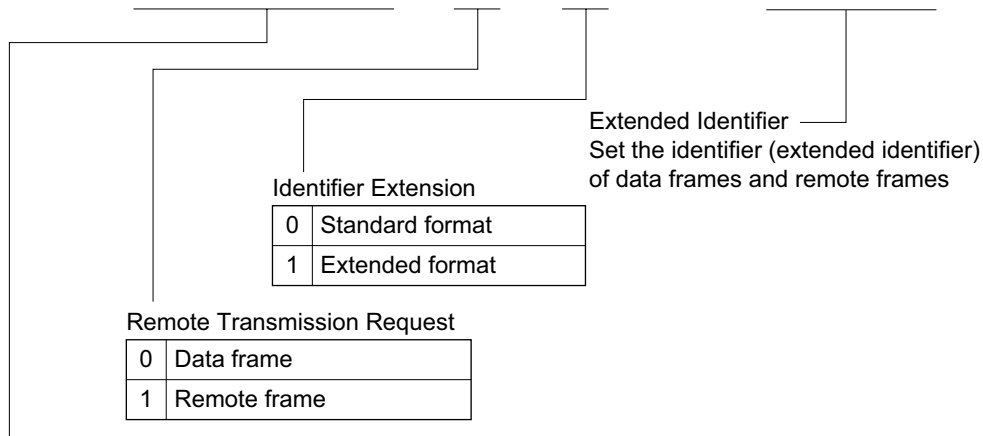

Identifier Extension

0	Standard format
1	Extended format

Remote Transmission Request

0	Data frame
1	Remote frame

Extended Identifier
Set the identifier (extended identifier) of data frames and remote frames

Standard Identifier
Set the identifier (standard identifier) of data frames and remote frames

MC8[6]

Bit	7	6	5	4	3	2	1	0
	STD_ID10	STD_ID9	STD_ID8	STD_ID7	STD_ID6	STD_ID5	STD_ID4	STD_ID3
Initial value	Undefined	Undefined	Undefined	Undefined	Undefined	Undefined	Undefined	Undefined
Read/Write	R/W	R/W	R/W	R/W	R/W	R/W	R/W	R/W

Standard Identifier
Set the identifier (standard identifier) of data frames and remote frames

MC8[7]

Bit	7	6	5	4	3	2	1	0
	EXD_ID7	EXD_ID6	EXD_ID5	EXD_ID4	EXD_ID3	EXD_ID2	EXD_ID1	EXD_ID0
Initial value	Undefined	Undefined	Undefined	Undefined	Undefined	Undefined	Undefined	Undefined
Read/Write	R/W	R/W	R/W	R/W	R/W	R/W	R/W	R/W

Extended Identifier _____

Set the identifier (extended identifier) of data frames and remote frames

MC8[8]

Bit	7	6	5	4	3	2	1	0
	EXD_ID15	EXD_ID14	EXD_ID13	EXD_ID12	EXD_ID11	EXD_ID10	EXD_ID9	EXD_ID8
Initial value	Undefined	Undefined	Undefined	Undefined	Undefined	Undefined	Undefined	Undefined
Read/Write	R/W	R/W	R/W	R/W	R/W	R/W	R/W	R/W

Extended Identifier _____

Set the identifier (extended identifier) of data frames and remote frames

MC9[1]—Message Control 9[1]	H'FA68	HCAN1
MC9[2]—Message Control 9[2]	H'FA69	HCAN1
MC9[3]—Message Control 9[3]	H'FA6A	HCAN1
MC9[4]—Message Control 9[4]	H'FA6B	HCAN1
MC9[5]—Message Control 9[5]	H'FA6C	HCAN1
MC9[6]—Message Control 9[6]	H'FA6D	HCAN1
MC9[7]—Message Control 9[7]	H'FA6E	HCAN1
MC9[8]—Message Control 9[8]	H'FA6F	HCAN1

Note: These registers are not available in the H8S/2635 and H8S/2634.

MC9[1]

Bit	7	6	5	4	3	2	1	0
	—	—	—	—	DLC3	DLC2	DLC1	DLC0
Initial value	Undefined	Undefined	Undefined	Undefined	Undefined	Undefined	Undefined	Undefined
Read/Write	R/W	R/W	R/W	R/W	R/W	R/W	R/W	R/W

Data Length Code

0	0	0	0	Data length = 0 bytes
		1		Data length = 1 byte
		1	0	Data length = 2 bytes
			1	Data length = 3 bytes
	1	0	0	Data length = 4 bytes
			1	Data length = 5 bytes
		1	0	Data length = 6 bytes
			1	Data length = 7 bytes
1	0/1	0/1	0/1	Data length = 8 bytes

MC9[2]

Bit	7	6	5	4	3	2	1	0
	—	—	—	—	—	—	—	—
Initial value	Undefined	Undefined	Undefined	Undefined	Undefined	Undefined	Undefined	Undefined
Read/Write	R/W	R/W	R/W	R/W	R/W	R/W	R/W	R/W

MC9[3]

Bit	7	6	5	4	3	2	1	0
	—	—	—	—	—	—	—	—
Initial value	Undefined	Undefined	Undefined	Undefined	Undefined	Undefined	Undefined	Undefined
Read/Write	R/W	R/W	R/W	R/W	R/W	R/W	R/W	R/W

MC9[4]

Bit	7	6	5	4	3	2	1	0
	—	—	—	—	—	—	—	—
Initial value	Undefined	Undefined	Undefined	Undefined	Undefined	Undefined	Undefined	Undefined
Read/Write	R/W	R/W	R/W	R/W	R/W	R/W	R/W	R/W

MC9[5]

Bit	7	6	5	4	3	2	1	0
	STD_ID2	STD_ID1	STD_ID0	RTR	IDE	—	EXD_ID17	EXD_ID16
Initial value	Undefined	Undefined	Undefined	Undefined	Undefined	Undefined	Undefined	Undefined
Read/Write	R/W	R/W	R/W	R/W	R/W	R/W	R/W	R/W

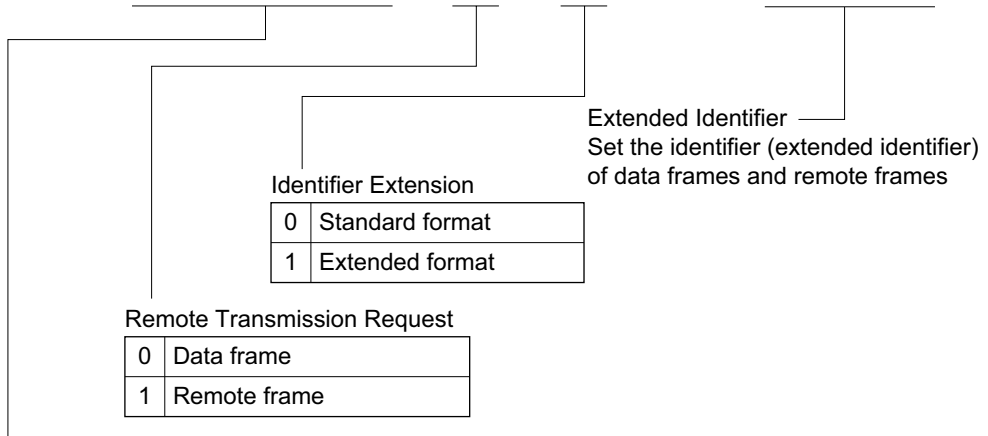

Standard Identifier

Set the identifier (standard identifier) of data frames and remote frames

MC9[6]

Bit	7	6	5	4	3	2	1	0
	STD_ID10	STD_ID9	STD_ID8	STD_ID7	STD_ID6	STD_ID5	STD_ID4	STD_ID3
Initial value	Undefined	Undefined	Undefined	Undefined	Undefined	Undefined	Undefined	Undefined
Read/Write	R/W	R/W	R/W	R/W	R/W	R/W	R/W	R/W

Standard Identifier
Set the identifier (standard identifier) of data frames and remote frames

MC9[7]

Bit	7	6	5	4	3	2	1	0
	EXD_ID7	EXD_ID6	EXD_ID5	EXD_ID4	EXD_ID3	EXD_ID2	EXD_ID1	EXD_ID0
Initial value	Undefined	Undefined	Undefined	Undefined	Undefined	Undefined	Undefined	Undefined
Read/Write	R/W	R/W	R/W	R/W	R/W	R/W	R/W	R/W

Extended Identifier

Set the identifier (extended identifier) of data frames and remote frames

MC9[8]

Bit	7	6	5	4	3	2	1	0
	EXD_ID15	EXD_ID14	EXD_ID13	EXD_ID12	EXD_ID11	EXD_ID10	EXD_ID9	EXD_ID8
Initial value	Undefined	Undefined	Undefined	Undefined	Undefined	Undefined	Undefined	Undefined
Read/Write	R/W	R/W	R/W	R/W	R/W	R/W	R/W	R/W

Extended Identifier

Set the identifier (extended identifier) of data frames and remote frames

MC10[1]—Message Control 10[1]	H'FA70	HCAN1
MC10[2]—Message Control 10[2]	H'FA71	HCAN1
MC10[3]—Message Control 10[3]	H'FA72	HCAN1
MC10[4]—Message Control 10[4]	H'FA73	HCAN1
MC10[5]—Message Control 10[5]	H'FA74	HCAN1
MC10[6]—Message Control 10[6]	H'FA75	HCAN1
MC10[7]—Message Control 10[7]	H'FA76	HCAN1
MC10[8]—Message Control 10[8]	H'FA77	HCAN1

Note: These registers are not available in the H8S/2635 and H8S/2634.

MC10[1]

Bit	7	6	5	4	3	2	1	0
	—	—	—	—	DLC3	DLC2	DLC1	DLC0
Initial value	Undefined	Undefined	Undefined	Undefined	Undefined	Undefined	Undefined	Undefined
Read/Write	R/W	R/W	R/W	R/W	R/W	R/W	R/W	R/W

Data Length Code

0	0	0	Data length = 0 bytes
		1	Data length = 1 byte
	1	0	Data length = 2 bytes
		1	Data length = 3 bytes
1	0	0	Data length = 4 bytes
		1	Data length = 5 bytes
	1	0	Data length = 6 bytes
		1	Data length = 7 bytes
1	0/1	0/1	Data length = 8 bytes

MC10[2]

Bit	7	6	5	4	3	2	1	0
	—	—	—	—	—	—	—	—
Initial value	Undefined	Undefined	Undefined	Undefined	Undefined	Undefined	Undefined	Undefined
Read/Write	R/W	R/W	R/W	R/W	R/W	R/W	R/W	R/W

MC10[3]

Bit	7	6	5	4	3	2	1	0
	—	—	—	—	—	—	—	—
Initial value	Undefined	Undefined	Undefined	Undefined	Undefined	Undefined	Undefined	Undefined
Read/Write	R/W	R/W	R/W	R/W	R/W	R/W	R/W	R/W

MC10[4]

Bit	7	6	5	4	3	2	1	0
	—	—	—	—	—	—	—	—
Initial value	Undefined	Undefined	Undefined	Undefined	Undefined	Undefined	Undefined	Undefined
Read/Write	R/W	R/W	R/W	R/W	R/W	R/W	R/W	R/W

MC10[5]

Bit	7	6	5	4	3	2	1	0
	STD_ID2	STD_ID1	STD_ID0	RTR	IDE	—	EXD_ID17	EXD_ID16
Initial value	Undefined	Undefined	Undefined	Undefined	Undefined	Undefined	Undefined	Undefined
Read/Write	R/W	R/W	R/W	R/W	R/W	R/W	R/W	R/W

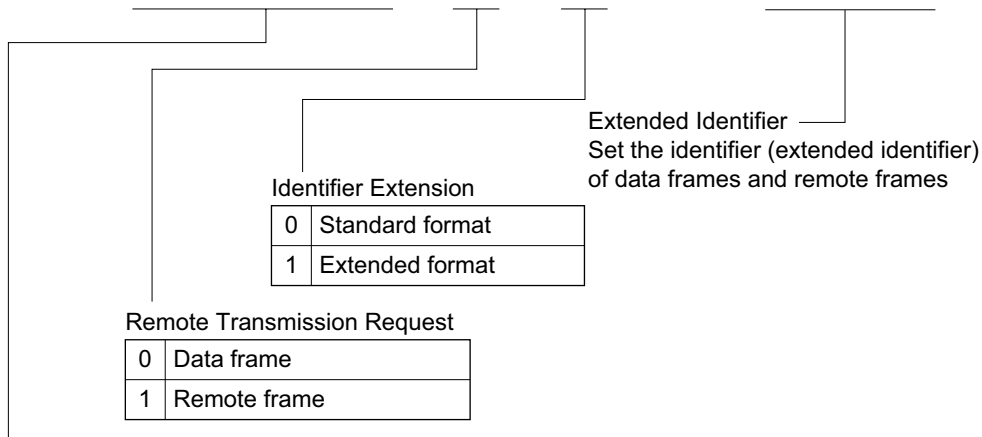

Identifier Extension

0	Standard format
1	Extended format

Remote Transmission Request

0	Data frame
1	Remote frame

Extended Identifier
Set the identifier (extended identifier) of data frames and remote frames

Standard Identifier
Set the identifier (standard identifier) of data frames and remote frames

MC10[6]

Bit	7	6	5	4	3	2	1	0
	STD_ID10	STD_ID9	STD_ID8	STD_ID7	STD_ID6	STD_ID5	STD_ID4	STD_ID3
Initial value	Undefined	Undefined	Undefined	Undefined	Undefined	Undefined	Undefined	Undefined
Read/Write	R/W	R/W	R/W	R/W	R/W	R/W	R/W	R/W

Standard Identifier
Set the identifier (standard identifier) of data frames and remote frames

MC10[7]

Bit	7	6	5	4	3	2	1	0
	EXD_ID7	EXD_ID6	EXD_ID5	EXD_ID4	EXD_ID3	EXD_ID2	EXD_ID1	EXD_ID0
Initial value	Undefined	Undefined	Undefined	Undefined	Undefined	Undefined	Undefined	Undefined
Read/Write	R/W	R/W	R/W	R/W	R/W	R/W	R/W	R/W

Extended Identifier _____

Set the identifier (extended identifier) of data frames and remote frames

MC10[8]

Bit	7	6	5	4	3	2	1	0
	EXD_ID15	EXD_ID14	EXD_ID13	EXD_ID12	EXD_ID11	EXD_ID10	EXD_ID9	EXD_ID8
Initial value	Undefined	Undefined	Undefined	Undefined	Undefined	Undefined	Undefined	Undefined
Read/Write	R/W	R/W	R/W	R/W	R/W	R/W	R/W	R/W

Extended Identifier _____

Set the identifier (extended identifier) of data frames and remote frames

MC11[1]—Message Control 11[1]	H'FA78	HCAN1
MC11[2]—Message Control 11[2]	H'FA79	HCAN1
MC11[3]—Message Control 11[3]	H'FA7A	HCAN1
MC11[4]—Message Control 11[4]	H'FA7B	HCAN1
MC11[5]—Message Control 11[5]	H'FA7C	HCAN1
MC11[6]—Message Control 11[6]	H'FA7D	HCAN1
MC11[7]—Message Control 11[7]	H'FA7E	HCAN1
MC11[8]—Message Control 11[8]	H'FA7F	HCAN1

Note: These registers are not available in the H8S/2635 and H8S/2634.

MC11[1]

Bit	7	6	5	4	3	2	1	0
	—	—	—	—	DLC3	DLC2	DLC1	DLC0
Initial value	Undefined	Undefined	Undefined	Undefined	Undefined	Undefined	Undefined	Undefined
Read/Write	R/W	R/W	R/W	R/W	R/W	R/W	R/W	R/W

Data Length Code

0	0	0	0	Data length = 0 bytes
		1		Data length = 1 byte
		1	0	Data length = 2 bytes
			1	Data length = 3 bytes
	1	0	0	Data length = 4 bytes
			1	Data length = 5 bytes
		1	0	Data length = 6 bytes
			1	Data length = 7 bytes
1	0/1	0/1	0/1	Data length = 8 bytes

MC11[2]

Bit	7	6	5	4	3	2	1	0
	—	—	—	—	—	—	—	—
Initial value	Undefined	Undefined	Undefined	Undefined	Undefined	Undefined	Undefined	Undefined
Read/Write	R/W	R/W	R/W	R/W	R/W	R/W	R/W	R/W

MC11[3]

Bit	7	6	5	4	3	2	1	0
	—	—	—	—	—	—	—	—
Initial value	Undefined	Undefined	Undefined	Undefined	Undefined	Undefined	Undefined	Undefined
Read/Write	R/W	R/W	R/W	R/W	R/W	R/W	R/W	R/W

MC11[4]

Bit	7	6	5	4	3	2	1	0
	—	—	—	—	—	—	—	—
Initial value	Undefined	Undefined	Undefined	Undefined	Undefined	Undefined	Undefined	Undefined
Read/Write	R/W	R/W	R/W	R/W	R/W	R/W	R/W	R/W

MC11[5]

Bit	7	6	5	4	3	2	1	0
	STD_ID2	STD_ID1	STD_ID0	RTR	IDE	—	EXD_ID17	EXD_ID16
Initial value	Undefined	Undefined	Undefined	Undefined	Undefined	Undefined	Undefined	Undefined
Read/Write	R/W	R/W	R/W	R/W	R/W	R/W	R/W	R/W

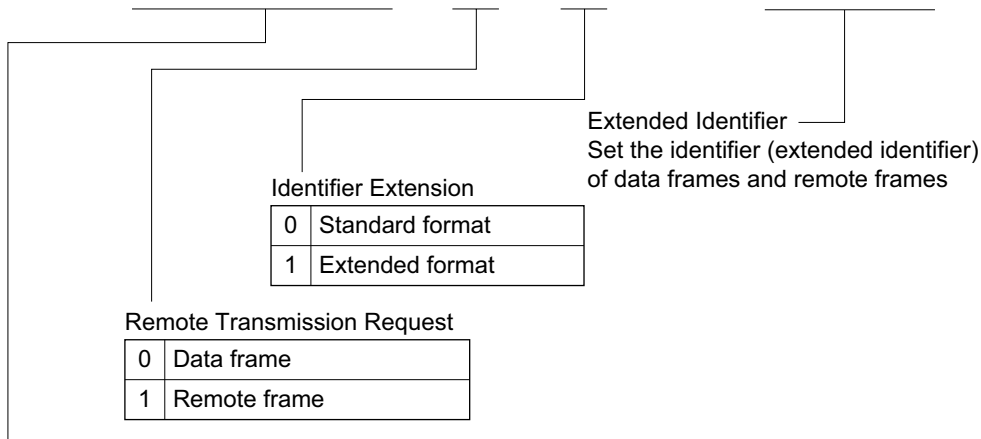

Standard Identifier

Set the identifier (standard identifier) of data frames and remote frames

MC11[6]

Bit	7	6	5	4	3	2	1	0
	STD_ID10	STD_ID9	STD_ID8	STD_ID7	STD_ID6	STD_ID5	STD_ID4	STD_ID3
Initial value	Undefined	Undefined	Undefined	Undefined	Undefined	Undefined	Undefined	Undefined
Read/Write	R/W	R/W	R/W	R/W	R/W	R/W	R/W	R/W

Standard Identifier
Set the identifier (standard identifier) of data frames and remote frames

MC11[7]

Bit	7	6	5	4	3	2	1	0
	EXD_ID7	EXD_ID6	EXD_ID5	EXD_ID4	EXD_ID3	EXD_ID2	EXD_ID1	EXD_ID0
Initial value	Undefined	Undefined	Undefined	Undefined	Undefined	Undefined	Undefined	Undefined
Read/Write	R/W	R/W	R/W	R/W	R/W	R/W	R/W	R/W

Extended Identifier _____

Set the identifier (extended identifier) of data frames and remote frames

MC11[8]

Bit	7	6	5	4	3	2	1	0
	EXD_ID15	EXD_ID14	EXD_ID13	EXD_ID12	EXD_ID11	EXD_ID10	EXD_ID9	EXD_ID8
Initial value	Undefined	Undefined	Undefined	Undefined	Undefined	Undefined	Undefined	Undefined
Read/Write	R/W	R/W	R/W	R/W	R/W	R/W	R/W	R/W

Extended Identifier _____

Set the identifier (extended identifier) of data frames and remote frames

MC12[1]—Message Control 12[1]	H'FA80	HCAN1
MC12[2]—Message Control 12[2]	H'FA81	HCAN1
MC12[3]—Message Control 12[3]	H'FA82	HCAN1
MC12[4]—Message Control 12[4]	H'FA83	HCAN1
MC12[5]—Message Control 12[5]	H'FA84	HCAN1
MC12[6]—Message Control 12[6]	H'FA85	HCAN1
MC12[7]—Message Control 12[7]	H'FA86	HCAN1
MC12[8]—Message Control 12[8]	H'FA87	HCAN1

Note: These registers are not available in the H8S/2635 and H8S/2634.

MC12[1]

Bit	7	6	5	4	3	2	1	0
	—	—	—	—	DLC3	DLC2	DLC1	DLC0
Initial value	Undefined	Undefined	Undefined	Undefined	Undefined	Undefined	Undefined	Undefined
Read/Write	R/W	R/W	R/W	R/W	R/W	R/W	R/W	R/W

Data Length Code

0	0	0	Data length = 0 bytes
		1	Data length = 1 byte
	1	0	Data length = 2 bytes
		1	Data length = 3 bytes
1	0	0	Data length = 4 bytes
		1	Data length = 5 bytes
	1	0	Data length = 6 bytes
		1	Data length = 7 bytes
1	0/1	0/1	Data length = 8 bytes

MC12[2]

Bit	7	6	5	4	3	2	1	0
	—	—	—	—	—	—	—	—
Initial value	Undefined	Undefined	Undefined	Undefined	Undefined	Undefined	Undefined	Undefined
Read/Write	R/W	R/W	R/W	R/W	R/W	R/W	R/W	R/W

MC12[3]

Bit	7	6	5	4	3	2	1	0
	—	—	—	—	—	—	—	—
Initial value	Undefined	Undefined	Undefined	Undefined	Undefined	Undefined	Undefined	Undefined
Read/Write	R/W	R/W	R/W	R/W	R/W	R/W	R/W	R/W

MC12[4]

Bit	7	6	5	4	3	2	1	0
	—	—	—	—	—	—	—	—
Initial value	Undefined	Undefined	Undefined	Undefined	Undefined	Undefined	Undefined	Undefined
Read/Write	R/W	R/W	R/W	R/W	R/W	R/W	R/W	R/W

MC12[5]

Bit	7	6	5	4	3	2	1	0
	STD_ID2	STD_ID1	STD_ID0	RTR	IDE	—	EXD_ID17	EXD_ID16
Initial value	Undefined	Undefined	Undefined	Undefined	Undefined	Undefined	Undefined	Undefined
Read/Write	R/W	R/W	R/W	R/W	R/W	R/W	R/W	R/W

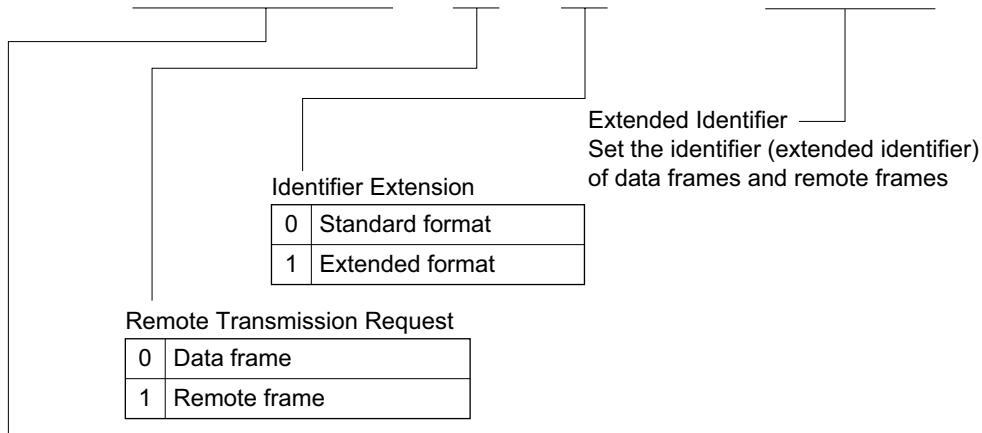

Identifier Extension

0	Standard format
1	Extended format

Remote Transmission Request

0	Data frame
1	Remote frame

Standard Identifier

Set the identifier (standard identifier) of data frames and remote frames

MC12[6]

Bit	7	6	5	4	3	2	1	0
	STD_ID10	STD_ID9	STD_ID8	STD_ID7	STD_ID6	STD_ID5	STD_ID4	STD_ID3
Initial value	Undefined	Undefined	Undefined	Undefined	Undefined	Undefined	Undefined	Undefined
Read/Write	R/W	R/W	R/W	R/W	R/W	R/W	R/W	R/W

Standard Identifier
Set the identifier (standard identifier) of data frames and remote frames

MC12[7]

Bit	7	6	5	4	3	2	1	0
	EXD_ID7	EXD_ID6	EXD_ID5	EXD_ID4	EXD_ID3	EXD_ID2	EXD_ID1	EXD_ID0
Initial value	Undefined	Undefined	Undefined	Undefined	Undefined	Undefined	Undefined	Undefined
Read/Write	R/W	R/W	R/W	R/W	R/W	R/W	R/W	R/W

Extended Identifier _____

Set the identifier (extended identifier) of data frames and remote frames

MC12[8]

Bit	7	6	5	4	3	2	1	0
	EXD_ID15	EXD_ID14	EXD_ID13	EXD_ID12	EXD_ID11	EXD_ID10	EXD_ID9	EXD_ID8
Initial value	Undefined	Undefined	Undefined	Undefined	Undefined	Undefined	Undefined	Undefined
Read/Write	R/W	R/W	R/W	R/W	R/W	R/W	R/W	R/W

Extended Identifier _____

Set the identifier (extended identifier) of data frames and remote frames

MC13[1]—Message Control 13[1]	H'FA88	HCAN1
MC13[2]—Message Control 13[2]	H'FA89	HCAN1
MC13[3]—Message Control 13[3]	H'FA8A	HCAN1
MC13[4]—Message Control 13[4]	H'FA8B	HCAN1
MC13[5]—Message Control 13[5]	H'FA8C	HCAN1
MC13[6]—Message Control 13[6]	H'FA8D	HCAN1
MC13[7]—Message Control 13[7]	H'FA8E	HCAN1
MC13[8]—Message Control 13[8]	H'FA8F	HCAN1

Note: These registers are not available in the H8S/2635 and H8S/2634.

MC13[1]

Bit	7	6	5	4	3	2	1	0
	—	—	—	—	DLC3	DLC2	DLC1	DLC0
Initial value	Undefined	Undefined	Undefined	Undefined	Undefined	Undefined	Undefined	Undefined
Read/Write	R/W	R/W	R/W	R/W	R/W	R/W	R/W	R/W

Data Length Code

0	0	0	0	Data length = 0 bytes
		1		Data length = 1 byte
		1	0	Data length = 2 bytes
			1	Data length = 3 bytes
	1	0	0	Data length = 4 bytes
			1	Data length = 5 bytes
		1	0	Data length = 6 bytes
			1	Data length = 7 bytes
1	0/1	0/1	0/1	Data length = 8 bytes

MC13[2]

Bit	7	6	5	4	3	2	1	0
	—	—	—	—	—	—	—	—
Initial value	Undefined	Undefined	Undefined	Undefined	Undefined	Undefined	Undefined	Undefined
Read/Write	R/W	R/W	R/W	R/W	R/W	R/W	R/W	R/W

MC13[3]

Bit	7	6	5	4	3	2	1	0
	—	—	—	—	—	—	—	—
Initial value	Undefined	Undefined	Undefined	Undefined	Undefined	Undefined	Undefined	Undefined
Read/Write	R/W	R/W	R/W	R/W	R/W	R/W	R/W	R/W

MC13[4]

Bit	7	6	5	4	3	2	1	0
	—	—	—	—	—	—	—	—
Initial value	Undefined	Undefined	Undefined	Undefined	Undefined	Undefined	Undefined	Undefined
Read/Write	R/W	R/W	R/W	R/W	R/W	R/W	R/W	R/W

MC13[5]

Bit	7	6	5	4	3	2	1	0
	STD_ID2	STD_ID1	STD_ID0	RTR	IDE	—	EXD_ID17	EXD_ID16
Initial value	Undefined	Undefined	Undefined	Undefined	Undefined	Undefined	Undefined	Undefined
Read/Write	R/W	R/W	R/W	R/W	R/W	R/W	R/W	R/W

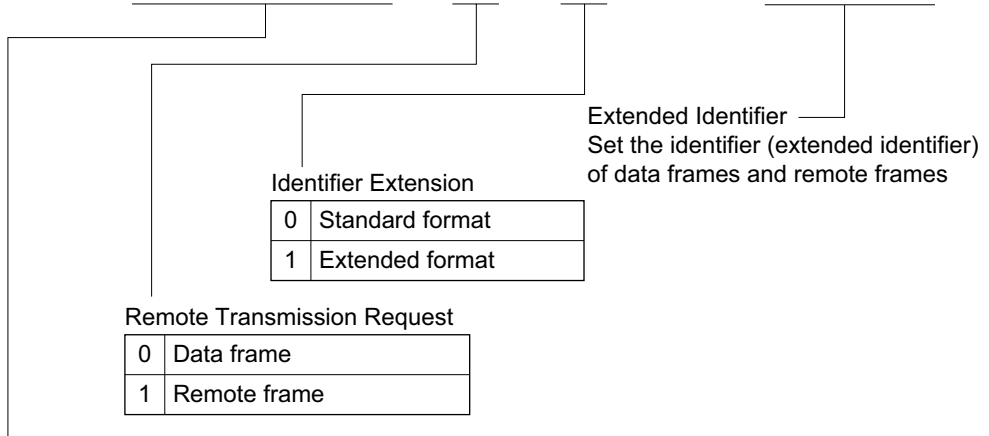

Standard Identifier

Set the identifier (standard identifier) of data frames and remote frames

MC13[6]

Bit	7	6	5	4	3	2	1	0
	STD_ID10	STD_ID9	STD_ID8	STD_ID7	STD_ID6	STD_ID5	STD_ID4	STD_ID3
Initial value	Undefined	Undefined	Undefined	Undefined	Undefined	Undefined	Undefined	Undefined
Read/Write	R/W	R/W	R/W	R/W	R/W	R/W	R/W	R/W

Standard Identifier
Set the identifier (standard identifier) of data frames and remote frames

MC13[7]

Bit	7	6	5	4	3	2	1	0
	EXD_ID7	EXD_ID6	EXD_ID5	EXD_ID4	EXD_ID3	EXD_ID2	EXD_ID1	EXD_ID0
Initial value	Undefined	Undefined	Undefined	Undefined	Undefined	Undefined	Undefined	Undefined
Read/Write	R/W	R/W	R/W	R/W	R/W	R/W	R/W	R/W

Extended Identifier _____

Set the identifier (extended identifier) of data frames and remote frames

MC13[8]

Bit	7	6	5	4	3	2	1	0
	EXD_ID15	EXD_ID14	EXD_ID13	EXD_ID12	EXD_ID11	EXD_ID10	EXD_ID9	EXD_ID8
Initial value	Undefined	Undefined	Undefined	Undefined	Undefined	Undefined	Undefined	Undefined
Read/Write	R/W	R/W	R/W	R/W	R/W	R/W	R/W	R/W

Extended Identifier _____

Set the identifier (extended identifier) of data frames and remote frames

MC14[1]—Message Control 14[1]	H'FA90	HCAN1
MC14[2]—Message Control 14[2]	H'FA91	HCAN1
MC14[3]—Message Control 14[3]	H'FA92	HCAN1
MC14[4]—Message Control 14[4]	H'FA93	HCAN1
MC14[5]—Message Control 14[5]	H'FA94	HCAN1
MC14[6]—Message Control 14[6]	H'FA95	HCAN1
MC14[7]—Message Control 14[7]	H'FA96	HCAN1
MC14[8]—Message Control 14[8]	H'FA97	HCAN1

Note: These registers are not available in the H8S/2635 and H8S/2634.

MC14[1]

Bit	7	6	5	4	3	2	1	0
	—	—	—	—	DLC3	DLC2	DLC1	DLC0
Initial value	Undefined	Undefined	Undefined	Undefined	Undefined	Undefined	Undefined	Undefined
Read/Write	R/W	R/W	R/W	R/W	R/W	R/W	R/W	R/W

Data Length Code

0	0	0	0	Data length = 0 bytes	
		1	0	Data length = 1 byte	
		1	0	0	Data length = 2 bytes
			1	0	Data length = 3 bytes
	1	0	0	0	Data length = 4 bytes
			1	0	Data length = 5 bytes
		1	0	0	Data length = 6 bytes
			1	0	Data length = 7 bytes
1	0/1	0/1	0/1	Data length = 8 bytes	

MC14[2]

Bit	7	6	5	4	3	2	1	0
	—	—	—	—	—	—	—	—
Initial value	Undefined	Undefined	Undefined	Undefined	Undefined	Undefined	Undefined	Undefined
Read/Write	R/W	R/W	R/W	R/W	R/W	R/W	R/W	R/W

MC14[3]

Bit	7	6	5	4	3	2	1	0
	—	—	—	—	—	—	—	—
Initial value	Undefined	Undefined	Undefined	Undefined	Undefined	Undefined	Undefined	Undefined
Read/Write	R/W	R/W	R/W	R/W	R/W	R/W	R/W	R/W

MC14[4]

Bit	7	6	5	4	3	2	1	0
	—	—	—	—	—	—	—	—
Initial value	Undefined	Undefined	Undefined	Undefined	Undefined	Undefined	Undefined	Undefined
Read/Write	R/W	R/W	R/W	R/W	R/W	R/W	R/W	R/W

MC14[5]

Bit	7	6	5	4	3	2	1	0
	STD_ID2	STD_ID1	STD_ID0	RTR	IDE	—	EXD_ID17	EXD_ID16
Initial value	Undefined	Undefined	Undefined	Undefined	Undefined	Undefined	Undefined	Undefined
Read/Write	R/W	R/W	R/W	R/W	R/W	R/W	R/W	R/W

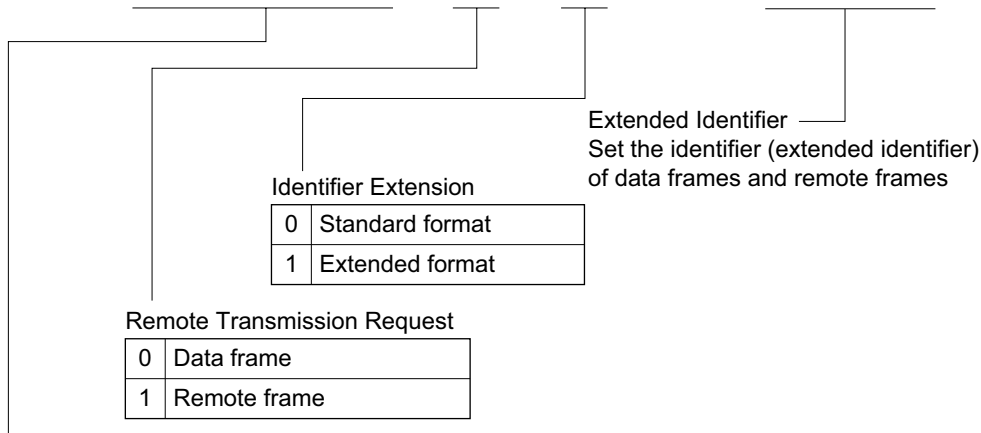

Identifier Extension

0	Standard format
1	Extended format

Remote Transmission Request

0	Data frame
1	Remote frame

Extended Identifier
Set the identifier (extended identifier) of data frames and remote frames

Standard Identifier
Set the identifier (standard identifier) of data frames and remote frames

MC14[6]

Bit	7	6	5	4	3	2	1	0
	STD_ID10	STD_ID9	STD_ID8	STD_ID7	STD_ID6	STD_ID5	STD_ID4	STD_ID3
Initial value	Undefined	Undefined	Undefined	Undefined	Undefined	Undefined	Undefined	Undefined
Read/Write	R/W	R/W	R/W	R/W	R/W	R/W	R/W	R/W

Standard Identifier
Set the identifier (standard identifier) of data frames and remote frames



MC14[7]

Bit	7	6	5	4	3	2	1	0
	EXD_ID7	EXD_ID6	EXD_ID5	EXD_ID4	EXD_ID3	EXD_ID2	EXD_ID1	EXD_ID0
Initial value	Undefined	Undefined	Undefined	Undefined	Undefined	Undefined	Undefined	Undefined
Read/Write	R/W	R/W	R/W	R/W	R/W	R/W	R/W	R/W

Extended Identifier _____

Set the identifier (extended identifier) of data frames and remote frames

MC14[8]

Bit	7	6	5	4	3	2	1	0
	EXD_ID15	EXD_ID14	EXD_ID13	EXD_ID12	EXD_ID11	EXD_ID10	EXD_ID9	EXD_ID8
Initial value	Undefined	Undefined	Undefined	Undefined	Undefined	Undefined	Undefined	Undefined
Read/Write	R/W	R/W	R/W	R/W	R/W	R/W	R/W	R/W

Extended Identifier _____

Set the identifier (extended identifier) of data frames and remote frames

MC15[1]—Message Control 15[1]	H'FA98	HCAN1
MC15[2]—Message Control 15[2]	H'FA99	HCAN1
MC15[3]—Message Control 15[3]	H'FA9A	HCAN1
MC15[4]—Message Control 15[4]	H'FA9B	HCAN1
MC15[5]—Message Control 15[5]	H'FA9C	HCAN1
MC15[6]—Message Control 15[6]	H'FA9D	HCAN1
MC15[7]—Message Control 15[7]	H'FA9E	HCAN1
MC15[8]—Message Control 15[8]	H'FA9F	HCAN1

Note: These registers are not available in the H8S/2635 and H8S/2634.

MC15[1]

Bit	7	6	5	4	3	2	1	0
	—	—	—	—	DLC3	DLC2	DLC1	DLC0
Initial value	Undefined	Undefined	Undefined	Undefined	Undefined	Undefined	Undefined	Undefined
Read/Write	R/W	R/W	R/W	R/W	R/W	R/W	R/W	R/W

Data Length Code

0	0	0	0	Data length = 0 bytes
		1		Data length = 1 byte
		1	0	Data length = 2 bytes
			1	Data length = 3 bytes
	1	0	0	Data length = 4 bytes
			1	Data length = 5 bytes
		1	0	Data length = 6 bytes
			1	Data length = 7 bytes
1	0/1	0/1	0/1	Data length = 8 bytes

MC15[2]

Bit	7	6	5	4	3	2	1	0
	—	—	—	—	—	—	—	—
Initial value	Undefined	Undefined	Undefined	Undefined	Undefined	Undefined	Undefined	Undefined
Read/Write	R/W	R/W	R/W	R/W	R/W	R/W	R/W	R/W

MC15[3]

Bit	7	6	5	4	3	2	1	0
	—	—	—	—	—	—	—	—
Initial value	Undefined	Undefined	Undefined	Undefined	Undefined	Undefined	Undefined	Undefined
Read/Write	R/W	R/W	R/W	R/W	R/W	R/W	R/W	R/W

MC15[4]

Bit	7	6	5	4	3	2	1	0
	—	—	—	—	—	—	—	—
Initial value	Undefined	Undefined	Undefined	Undefined	Undefined	Undefined	Undefined	Undefined
Read/Write	R/W	R/W	R/W	R/W	R/W	R/W	R/W	R/W

MC15[5]

Bit	7	6	5	4	3	2	1	0
	STD_ID2	STD_ID1	STD_ID0	RTR	IDE	—	EXD_ID17	EXD_ID16
Initial value	Undefined	Undefined	Undefined	Undefined	Undefined	Undefined	Undefined	Undefined
Read/Write	R/W	R/W	R/W	R/W	R/W	R/W	R/W	R/W

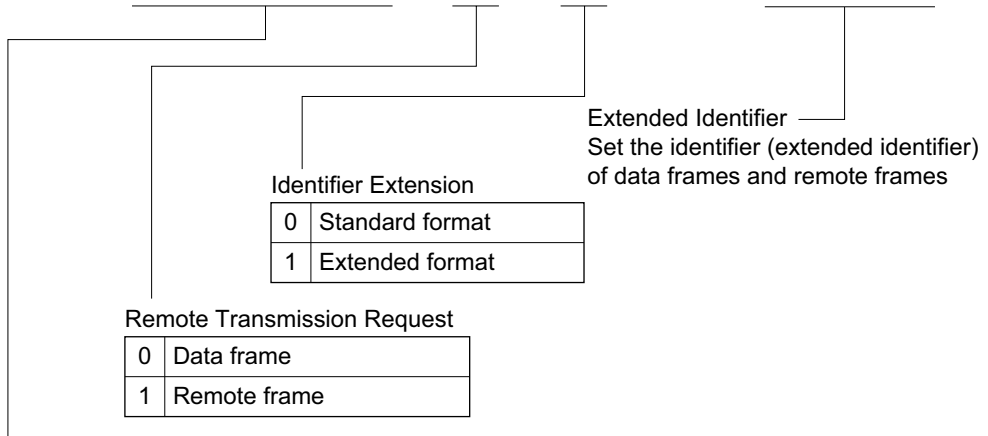

Standard Identifier

Set the identifier (standard identifier) of data frames and remote frames

MC15[6]

Bit	7	6	5	4	3	2	1	0
	STD_ID10	STD_ID9	STD_ID8	STD_ID7	STD_ID6	STD_ID5	STD_ID4	STD_ID3
Initial value	Undefined	Undefined	Undefined	Undefined	Undefined	Undefined	Undefined	Undefined
Read/Write	R/W	R/W	R/W	R/W	R/W	R/W	R/W	R/W

Standard Identifier
Set the identifier (standard identifier) of data frames and remote frames

MC15[7]

Bit	7	6	5	4	3	2	1	0
	EXD_ID7	EXD_ID6	EXD_ID5	EXD_ID4	EXD_ID3	EXD_ID2	EXD_ID1	EXD_ID0
Initial value	Undefined	Undefined	Undefined	Undefined	Undefined	Undefined	Undefined	Undefined
Read/Write	R/W	R/W	R/W	R/W	R/W	R/W	R/W	R/W

Extended Identifier _____

Set the identifier (extended identifier) of data frames and remote frames

MC15[8]

Bit	7	6	5	4	3	2	1	0
	EXD_ID15	EXD_ID14	EXD_ID13	EXD_ID12	EXD_ID11	EXD_ID10	EXD_ID9	EXD_ID8
Initial value	Undefined	Undefined	Undefined	Undefined	Undefined	Undefined	Undefined	Undefined
Read/Write	R/W	R/W	R/W	R/W	R/W	R/W	R/W	R/W

Extended Identifier _____

Set the identifier (extended identifier) of data frames and remote frames

MD0[1]—Message Data 0[1]	H'FAB0	HCAN1
MD0[2]—Message Data 0[2]	H'FAB1	HCAN1
MD0[3]—Message Data 0[3]	H'FAB2	HCAN1
MD0[4]—Message Data 0[4]	H'FAB3	HCAN1
MD0[5]—Message Data 0[5]	H'FAB4	HCAN1
MD0[6]—Message Data 0[6]	H'FAB5	HCAN1
MD0[7]—Message Data 0[7]	H'FAB6	HCAN1
MD0[8]—Message Data 0[8]	H'FAB7	HCAN1

Note: These registers are not available in the H8S/2635 and H8S/2634.

MDx[1]	Bit	7	6	5	4	3	2	1	0
		[] [] [] [] [] [] [] [] [] []							
	Initial value	*	*	*	*	*	*	*	*
	Read/Write	R/W	R/W	R/W	R/W	R/W	R/W	R/W	R/W
MDx[2]	Bit	7	6	5	4	3	2	1	0
		[] [] [] [] [] [] [] [] [] []							
	Initial value	*	*	*	*	*	*	*	*
	Read/Write	R/W	R/W	R/W	R/W	R/W	R/W	R/W	R/W
MDx[3]	Bit	7	6	5	4	3	2	1	0
		[] [] [] [] [] [] [] [] [] []							
	Initial value	*	*	*	*	*	*	*	*
	Read/Write	R/W	R/W	R/W	R/W	R/W	R/W	R/W	R/W
MDx[4]	Bit	7	6	5	4	3	2	1	0
		[] [] [] [] [] [] [] [] [] []							
	Initial value	*	*	*	*	*	*	*	*
	Read/Write	R/W	R/W	R/W	R/W	R/W	R/W	R/W	R/W
MDx[5]	Bit	7	6	5	4	3	2	1	0
		[] [] [] [] [] [] [] [] [] []							
	Initial value	*	*	*	*	*	*	*	*
	Read/Write	R/W	R/W	R/W	R/W	R/W	R/W	R/W	R/W
MDx[6]	Bit	7	6	5	4	3	2	1	0
		[] [] [] [] [] [] [] [] [] []							
	Initial value	*	*	*	*	*	*	*	*
	Read/Write	R/W	R/W	R/W	R/W	R/W	R/W	R/W	R/W
MDx[7]	Bit	7	6	5	4	3	2	1	0
		[] [] [] [] [] [] [] [] [] []							
	Initial value	*	*	*	*	*	*	*	*
	Read/Write	R/W	R/W	R/W	R/W	R/W	R/W	R/W	R/W
MDx[8]	Bit	7	6	5	4	3	2	1	0
		[] [] [] [] [] [] [] [] [] []							
	Initial value	*	*	*	*	*	*	*	*
	Read/Write	R/W	R/W	R/W	R/W	R/W	R/W	R/W	R/W

*: Undefined
x = 0 to 15

MD1[1]—Message Data 1[1]	H'FAB8	HCAN1
MD1[2]—Message Data 1[2]	H'FAB9	HCAN1
MD1[3]—Message Data 1[3]	H'FABA	HCAN1
MD1[4]—Message Data 1[4]	H'FABB	HCAN1
MD1[5]—Message Data 1[5]	H'FABC	HCAN1
MD1[6]—Message Data 1[6]	H'FABD	HCAN1
MD1[7]—Message Data 1[7]	H'FABE	HCAN1
MD1[8]—Message Data 1[8]	H'FABF	HCAN1

Note: These registers are not available in the H8S/2635 and H8S/2634.

MDx[1]	Bit	7	6	5	4	3	2	1	0
		[] [] [] [] [] [] [] [] [] []							
	Initial value	*	*	*	*	*	*	*	*
	Read/Write	R/W	R/W	R/W	R/W	R/W	R/W	R/W	R/W
MDx[2]	Bit	7	6	5	4	3	2	1	0
		[] [] [] [] [] [] [] [] [] []							
	Initial value	*	*	*	*	*	*	*	*
	Read/Write	R/W	R/W	R/W	R/W	R/W	R/W	R/W	R/W
MDx[3]	Bit	7	6	5	4	3	2	1	0
		[] [] [] [] [] [] [] [] [] []							
	Initial value	*	*	*	*	*	*	*	*
	Read/Write	R/W	R/W	R/W	R/W	R/W	R/W	R/W	R/W
MDx[4]	Bit	7	6	5	4	3	2	1	0
		[] [] [] [] [] [] [] [] [] []							
	Initial value	*	*	*	*	*	*	*	*
	Read/Write	R/W	R/W	R/W	R/W	R/W	R/W	R/W	R/W
MDx[5]	Bit	7	6	5	4	3	2	1	0
		[] [] [] [] [] [] [] [] [] []							
	Initial value	*	*	*	*	*	*	*	*
	Read/Write	R/W	R/W	R/W	R/W	R/W	R/W	R/W	R/W
MDx[6]	Bit	7	6	5	4	3	2	1	0
		[] [] [] [] [] [] [] [] [] []							
	Initial value	*	*	*	*	*	*	*	*
	Read/Write	R/W	R/W	R/W	R/W	R/W	R/W	R/W	R/W
MDx[7]	Bit	7	6	5	4	3	2	1	0
		[] [] [] [] [] [] [] [] [] []							
	Initial value	*	*	*	*	*	*	*	*
	Read/Write	R/W	R/W	R/W	R/W	R/W	R/W	R/W	R/W
MDx[8]	Bit	7	6	5	4	3	2	1	0
		[] [] [] [] [] [] [] [] [] []							
	Initial value	*	*	*	*	*	*	*	*
	Read/Write	R/W	R/W	R/W	R/W	R/W	R/W	R/W	R/W

*: Undefined
x = 0 to 15

MD2[1]—Message Data 2[1]	H'FAC0	HCAN1
MD2[2]—Message Data 2[2]	H'FAC1	HCAN1
MD2[3]—Message Data 2[3]	H'FAC2	HCAN1
MD2[4]—Message Data 2[4]	H'FAC3	HCAN1
MD2[5]—Message Data 2[5]	H'FAC4	HCAN1
MD2[6]—Message Data 2[6]	H'FAC5	HCAN1
MD2[7]—Message Data 2[7]	H'FAC6	HCAN1
MD2[8]—Message Data 2[8]	H'FAC7	HCAN1

Note: These registers are not available in the H8S/2635 and H8S/2634.

MDx[1]	Bit	7	6	5	4	3	2	1	0
		[] [] [] [] [] [] [] [] [] []							
	Initial value	*	*	*	*	*	*	*	*
	Read/Write	R/W	R/W	R/W	R/W	R/W	R/W	R/W	R/W
MDx[2]	Bit	7	6	5	4	3	2	1	0
		[] [] [] [] [] [] [] [] [] []							
	Initial value	*	*	*	*	*	*	*	*
	Read/Write	R/W	R/W	R/W	R/W	R/W	R/W	R/W	R/W
MDx[3]	Bit	7	6	5	4	3	2	1	0
		[] [] [] [] [] [] [] [] [] []							
	Initial value	*	*	*	*	*	*	*	*
	Read/Write	R/W	R/W	R/W	R/W	R/W	R/W	R/W	R/W
MDx[4]	Bit	7	6	5	4	3	2	1	0
		[] [] [] [] [] [] [] [] [] []							
	Initial value	*	*	*	*	*	*	*	*
	Read/Write	R/W	R/W	R/W	R/W	R/W	R/W	R/W	R/W
MDx[5]	Bit	7	6	5	4	3	2	1	0
		[] [] [] [] [] [] [] [] [] []							
	Initial value	*	*	*	*	*	*	*	*
	Read/Write	R/W	R/W	R/W	R/W	R/W	R/W	R/W	R/W
MDx[6]	Bit	7	6	5	4	3	2	1	0
		[] [] [] [] [] [] [] [] [] []							
	Initial value	*	*	*	*	*	*	*	*
	Read/Write	R/W	R/W	R/W	R/W	R/W	R/W	R/W	R/W
MDx[7]	Bit	7	6	5	4	3	2	1	0
		[] [] [] [] [] [] [] [] [] []							
	Initial value	*	*	*	*	*	*	*	*
	Read/Write	R/W	R/W	R/W	R/W	R/W	R/W	R/W	R/W
MDx[8]	Bit	7	6	5	4	3	2	1	0
		[] [] [] [] [] [] [] [] [] []							
	Initial value	*	*	*	*	*	*	*	*
	Read/Write	R/W	R/W	R/W	R/W	R/W	R/W	R/W	R/W

*: Undefined
x = 0 to 15

MD3[1]—Message Data 3[1]	H'FAC8	HCAN1
MD3[2]—Message Data 3[2]	H'FAC9	HCAN1
MD3[3]—Message Data 3[3]	H'FACA	HCAN1
MD3[4]—Message Data 3[4]	H'FACB	HCAN1
MD3[5]—Message Data 3[5]	H'FACC	HCAN1
MD3[6]—Message Data 3[6]	H'FACD	HCAN1
MD3[7]—Message Data 3[7]	H'FACE	HCAN1
MD3[8]—Message Data 3[8]	H'FACF	HCAN1

Note: These registers are not available in the H8S/2635 and H8S/2634.

MDx[1]	Bit	7	6	5	4	3	2	1	0
		[] [] [] [] [] [] [] [] [] []							
	Initial value	*	*	*	*	*	*	*	*
	Read/Write	R/W	R/W	R/W	R/W	R/W	R/W	R/W	R/W
MDx[2]	Bit	7	6	5	4	3	2	1	0
		[] [] [] [] [] [] [] [] [] []							
	Initial value	*	*	*	*	*	*	*	*
	Read/Write	R/W	R/W	R/W	R/W	R/W	R/W	R/W	R/W
MDx[3]	Bit	7	6	5	4	3	2	1	0
		[] [] [] [] [] [] [] [] [] []							
	Initial value	*	*	*	*	*	*	*	*
	Read/Write	R/W	R/W	R/W	R/W	R/W	R/W	R/W	R/W
MDx[4]	Bit	7	6	5	4	3	2	1	0
		[] [] [] [] [] [] [] [] [] []							
	Initial value	*	*	*	*	*	*	*	*
	Read/Write	R/W	R/W	R/W	R/W	R/W	R/W	R/W	R/W
MDx[5]	Bit	7	6	5	4	3	2	1	0
		[] [] [] [] [] [] [] [] [] []							
	Initial value	*	*	*	*	*	*	*	*
	Read/Write	R/W	R/W	R/W	R/W	R/W	R/W	R/W	R/W
MDx[6]	Bit	7	6	5	4	3	2	1	0
		[] [] [] [] [] [] [] [] [] []							
	Initial value	*	*	*	*	*	*	*	*
	Read/Write	R/W	R/W	R/W	R/W	R/W	R/W	R/W	R/W
MDx[7]	Bit	7	6	5	4	3	2	1	0
		[] [] [] [] [] [] [] [] [] []							
	Initial value	*	*	*	*	*	*	*	*
	Read/Write	R/W	R/W	R/W	R/W	R/W	R/W	R/W	R/W
MDx[8]	Bit	7	6	5	4	3	2	1	0
		[] [] [] [] [] [] [] [] [] []							
	Initial value	*	*	*	*	*	*	*	*
	Read/Write	R/W	R/W	R/W	R/W	R/W	R/W	R/W	R/W

*: Undefined
x = 0 to 15

MD4[1]—Message Data 4[1]	H'FAD0	HCAN1
MD4[2]—Message Data 4[2]	H'FAD1	HCAN1
MD4[3]—Message Data 4[3]	H'FAD2	HCAN1
MD4[4]—Message Data 4[4]	H'FAD3	HCAN1
MD4[5]—Message Data 4[5]	H'FAD4	HCAN1
MD4[6]—Message Data 4[6]	H'FAD5	HCAN1
MD4[7]—Message Data 4[7]	H'FAD6	HCAN1
MD4[8]—Message Data 4[8]	H'FAD7	HCAN1

Note: These registers are not available in the H8S/2635 and H8S/2634.

MDx[1]	Bit	7	6	5	4	3	2	1	0
		[] [] [] [] [] [] [] [] [] []							
	Initial value	*	*	*	*	*	*	*	*
	Read/Write	R/W	R/W	R/W	R/W	R/W	R/W	R/W	R/W
MDx[2]	Bit	7	6	5	4	3	2	1	0
		[] [] [] [] [] [] [] [] [] []							
	Initial value	*	*	*	*	*	*	*	*
	Read/Write	R/W	R/W	R/W	R/W	R/W	R/W	R/W	R/W
MDx[3]	Bit	7	6	5	4	3	2	1	0
		[] [] [] [] [] [] [] [] [] []							
	Initial value	*	*	*	*	*	*	*	*
	Read/Write	R/W	R/W	R/W	R/W	R/W	R/W	R/W	R/W
MDx[4]	Bit	7	6	5	4	3	2	1	0
		[] [] [] [] [] [] [] [] [] []							
	Initial value	*	*	*	*	*	*	*	*
	Read/Write	R/W	R/W	R/W	R/W	R/W	R/W	R/W	R/W
MDx[5]	Bit	7	6	5	4	3	2	1	0
		[] [] [] [] [] [] [] [] [] []							
	Initial value	*	*	*	*	*	*	*	*
	Read/Write	R/W	R/W	R/W	R/W	R/W	R/W	R/W	R/W
MDx[6]	Bit	7	6	5	4	3	2	1	0
		[] [] [] [] [] [] [] [] [] []							
	Initial value	*	*	*	*	*	*	*	*
	Read/Write	R/W	R/W	R/W	R/W	R/W	R/W	R/W	R/W
MDx[7]	Bit	7	6	5	4	3	2	1	0
		[] [] [] [] [] [] [] [] [] []							
	Initial value	*	*	*	*	*	*	*	*
	Read/Write	R/W	R/W	R/W	R/W	R/W	R/W	R/W	R/W
MDx[8]	Bit	7	6	5	4	3	2	1	0
		[] [] [] [] [] [] [] [] [] []							
	Initial value	*	*	*	*	*	*	*	*
	Read/Write	R/W	R/W	R/W	R/W	R/W	R/W	R/W	R/W

*: Undefined
x = 0 to 15

MD5[1]—Message Data 5[1]	H'FAD8	HCAN1
MD5[2]—Message Data 5[2]	H'FAD9	HCAN1
MD5[3]—Message Data 5[3]	H'FADA	HCAN1
MD5[4]—Message Data 5[4]	H'FADB	HCAN1
MD5[5]—Message Data 5[5]	H'FADC	HCAN1
MD5[6]—Message Data 5[6]	H'FADD	HCAN1
MD5[7]—Message Data 5[7]	H'FADE	HCAN1
MD5[8]—Message Data 5[8]	H'FADF	HCAN1

Note: These registers are not available in the H8S/2635 and H8S/2634.

MDx[1]	Bit	7	6	5	4	3	2	1	0
		[][][][][][][][][]							
	Initial value	*	*	*	*	*	*	*	*
	Read/Write	R/W	R/W	R/W	R/W	R/W	R/W	R/W	R/W
MDx[2]	Bit	7	6	5	4	3	2	1	0
		[][][][][][][][][]							
	Initial value	*	*	*	*	*	*	*	*
	Read/Write	R/W	R/W	R/W	R/W	R/W	R/W	R/W	R/W
MDx[3]	Bit	7	6	5	4	3	2	1	0
		[][][][][][][][][]							
	Initial value	*	*	*	*	*	*	*	*
	Read/Write	R/W	R/W	R/W	R/W	R/W	R/W	R/W	R/W
MDx[4]	Bit	7	6	5	4	3	2	1	0
		[][][][][][][][][]							
	Initial value	*	*	*	*	*	*	*	*
	Read/Write	R/W	R/W	R/W	R/W	R/W	R/W	R/W	R/W
MDx[5]	Bit	7	6	5	4	3	2	1	0
		[][][][][][][][][]							
	Initial value	*	*	*	*	*	*	*	*
	Read/Write	R/W	R/W	R/W	R/W	R/W	R/W	R/W	R/W
MDx[6]	Bit	7	6	5	4	3	2	1	0
		[][][][][][][][][]							
	Initial value	*	*	*	*	*	*	*	*
	Read/Write	R/W	R/W	R/W	R/W	R/W	R/W	R/W	R/W
MDx[7]	Bit	7	6	5	4	3	2	1	0
		[][][][][][][][][]							
	Initial value	*	*	*	*	*	*	*	*
	Read/Write	R/W	R/W	R/W	R/W	R/W	R/W	R/W	R/W
MDx[8]	Bit	7	6	5	4	3	2	1	0
		[][][][][][][][][]							
	Initial value	*	*	*	*	*	*	*	*
	Read/Write	R/W	R/W	R/W	R/W	R/W	R/W	R/W	R/W

*: Undefined
x = 0 to 15

MD6[1]—Message Data 6[1]	H'FAE0	HCAN1
MD6[2]—Message Data 6[2]	H'FAE1	HCAN1
MD6[3]—Message Data 6[3]	H'FAE2	HCAN1
MD6[4]—Message Data 6[4]	H'FAE3	HCAN1
MD6[5]—Message Data 6[5]	H'FAE4	HCAN1
MD6[6]—Message Data 6[6]	H'FAE5	HCAN1
MD6[7]—Message Data 6[7]	H'FAE6	HCAN1
MD6[8]—Message Data 6[8]	H'FAE7	HCAN1

Note: These registers are not available in the H8S/2635 and H8S/2634.

MDx[1]	Bit	7	6	5	4	3	2	1	0
		[] [] [] [] [] [] [] [] [] []							
	Initial value	*	*	*	*	*	*	*	*
	Read/Write	R/W	R/W	R/W	R/W	R/W	R/W	R/W	R/W
MDx[2]	Bit	7	6	5	4	3	2	1	0
		[] [] [] [] [] [] [] [] [] []							
	Initial value	*	*	*	*	*	*	*	*
	Read/Write	R/W	R/W	R/W	R/W	R/W	R/W	R/W	R/W
MDx[3]	Bit	7	6	5	4	3	2	1	0
		[] [] [] [] [] [] [] [] [] []							
	Initial value	*	*	*	*	*	*	*	*
	Read/Write	R/W	R/W	R/W	R/W	R/W	R/W	R/W	R/W
MDx[4]	Bit	7	6	5	4	3	2	1	0
		[] [] [] [] [] [] [] [] [] []							
	Initial value	*	*	*	*	*	*	*	*
	Read/Write	R/W	R/W	R/W	R/W	R/W	R/W	R/W	R/W
MDx[5]	Bit	7	6	5	4	3	2	1	0
		[] [] [] [] [] [] [] [] [] []							
	Initial value	*	*	*	*	*	*	*	*
	Read/Write	R/W	R/W	R/W	R/W	R/W	R/W	R/W	R/W
MDx[6]	Bit	7	6	5	4	3	2	1	0
		[] [] [] [] [] [] [] [] [] []							
	Initial value	*	*	*	*	*	*	*	*
	Read/Write	R/W	R/W	R/W	R/W	R/W	R/W	R/W	R/W
MDx[7]	Bit	7	6	5	4	3	2	1	0
		[] [] [] [] [] [] [] [] [] []							
	Initial value	*	*	*	*	*	*	*	*
	Read/Write	R/W	R/W	R/W	R/W	R/W	R/W	R/W	R/W
MDx[8]	Bit	7	6	5	4	3	2	1	0
		[] [] [] [] [] [] [] [] [] []							
	Initial value	*	*	*	*	*	*	*	*
	Read/Write	R/W	R/W	R/W	R/W	R/W	R/W	R/W	R/W

*: Undefined
x = 0 to 15

MD7[1]—Message Data 7[1]	H'FAE8	HCAN1
MD7[2]—Message Data 7[2]	H'FAE9	HCAN1
MD7[3]—Message Data 7[3]	H'FAEA	HCAN1
MD7[4]—Message Data 7[4]	H'FAEB	HCAN1
MD7[5]—Message Data 7[5]	H'FAEC	HCAN1
MD7[6]—Message Data 7[6]	H'FAED	HCAN1
MD7[7]—Message Data 7[7]	H'FAEE	HCAN1
MD7[8]—Message Data 7[8]	H'FAEF	HCAN1

Note: These registers are not available in the H8S/2635 and H8S/2634.

MDx[1]	Bit	7	6	5	4	3	2	1	0
		[][][][][][][][][]							
	Initial value	*	*	*	*	*	*	*	*
	Read/Write	R/W	R/W	R/W	R/W	R/W	R/W	R/W	R/W
MDx[2]	Bit	7	6	5	4	3	2	1	0
		[][][][][][][][][]							
	Initial value	*	*	*	*	*	*	*	*
	Read/Write	R/W	R/W	R/W	R/W	R/W	R/W	R/W	R/W
MDx[3]	Bit	7	6	5	4	3	2	1	0
		[][][][][][][][][]							
	Initial value	*	*	*	*	*	*	*	*
	Read/Write	R/W	R/W	R/W	R/W	R/W	R/W	R/W	R/W
MDx[4]	Bit	7	6	5	4	3	2	1	0
		[][][][][][][][][]							
	Initial value	*	*	*	*	*	*	*	*
	Read/Write	R/W	R/W	R/W	R/W	R/W	R/W	R/W	R/W
MDx[5]	Bit	7	6	5	4	3	2	1	0
		[][][][][][][][][]							
	Initial value	*	*	*	*	*	*	*	*
	Read/Write	R/W	R/W	R/W	R/W	R/W	R/W	R/W	R/W
MDx[6]	Bit	7	6	5	4	3	2	1	0
		[][][][][][][][][]							
	Initial value	*	*	*	*	*	*	*	*
	Read/Write	R/W	R/W	R/W	R/W	R/W	R/W	R/W	R/W
MDx[7]	Bit	7	6	5	4	3	2	1	0
		[][][][][][][][][]							
	Initial value	*	*	*	*	*	*	*	*
	Read/Write	R/W	R/W	R/W	R/W	R/W	R/W	R/W	R/W
MDx[8]	Bit	7	6	5	4	3	2	1	0
		[][][][][][][][][]							
	Initial value	*	*	*	*	*	*	*	*
	Read/Write	R/W	R/W	R/W	R/W	R/W	R/W	R/W	R/W

*: Undefined
x = 0 to 15

MD8[1]—Message Data 8[1]	H'FAF0	HCAN1
MD8[2]—Message Data 8[2]	H'FAF1	HCAN1
MD8[3]—Message Data 8[3]	H'FAF2	HCAN1
MD8[4]—Message Data 8[4]	H'FAF3	HCAN1
MD8[5]—Message Data 8[5]	H'FAF4	HCAN1
MD8[6]—Message Data 8[6]	H'FAF5	HCAN1
MD8[7]—Message Data 8[7]	H'FAF6	HCAN1
MD8[8]—Message Data 8[8]	H'FAF7	HCAN1

Note: These registers are not available in the H8S/2635 and H8S/2634.

MDx[1]	Bit	7	6	5	4	3	2	1	0
		[] [] [] [] [] [] [] [] [] []							
	Initial value	*	*	*	*	*	*	*	*
	Read/Write	R/W	R/W	R/W	R/W	R/W	R/W	R/W	R/W
MDx[2]	Bit	7	6	5	4	3	2	1	0
		[] [] [] [] [] [] [] [] [] []							
	Initial value	*	*	*	*	*	*	*	*
	Read/Write	R/W	R/W	R/W	R/W	R/W	R/W	R/W	R/W
MDx[3]	Bit	7	6	5	4	3	2	1	0
		[] [] [] [] [] [] [] [] [] []							
	Initial value	*	*	*	*	*	*	*	*
	Read/Write	R/W	R/W	R/W	R/W	R/W	R/W	R/W	R/W
MDx[4]	Bit	7	6	5	4	3	2	1	0
		[] [] [] [] [] [] [] [] [] []							
	Initial value	*	*	*	*	*	*	*	*
	Read/Write	R/W	R/W	R/W	R/W	R/W	R/W	R/W	R/W
MDx[5]	Bit	7	6	5	4	3	2	1	0
		[] [] [] [] [] [] [] [] [] []							
	Initial value	*	*	*	*	*	*	*	*
	Read/Write	R/W	R/W	R/W	R/W	R/W	R/W	R/W	R/W
MDx[6]	Bit	7	6	5	4	3	2	1	0
		[] [] [] [] [] [] [] [] [] []							
	Initial value	*	*	*	*	*	*	*	*
	Read/Write	R/W	R/W	R/W	R/W	R/W	R/W	R/W	R/W
MDx[7]	Bit	7	6	5	4	3	2	1	0
		[] [] [] [] [] [] [] [] [] []							
	Initial value	*	*	*	*	*	*	*	*
	Read/Write	R/W	R/W	R/W	R/W	R/W	R/W	R/W	R/W
MDx[8]	Bit	7	6	5	4	3	2	1	0
		[] [] [] [] [] [] [] [] [] []							
	Initial value	*	*	*	*	*	*	*	*
	Read/Write	R/W	R/W	R/W	R/W	R/W	R/W	R/W	R/W

*: Undefined
x = 0 to 15

MD9[1]—Message Data 9[1]	H'FAF8	HCAN1
MD9[2]—Message Data 9[2]	H'FAF9	HCAN1
MD9[3]—Message Data 9[3]	H'FAFA	HCAN1
MD9[4]—Message Data 9[4]	H'FAFB	HCAN1
MD9[5]—Message Data 9[5]	H'FAFC	HCAN1
MD9[6]—Message Data 9[6]	H'FAFD	HCAN1
MD9[7]—Message Data 9[7]	H'FAFE	HCAN1
MD9[8]—Message Data 9[8]	H'FAFF	HCAN1

Note: These registers are not available in the H8S/2635 and H8S/2634.

MDx[1]	Bit	7	6	5	4	3	2	1	0
		[] [] [] [] [] [] [] [] [] []							
	Initial value	*	*	*	*	*	*	*	*
	Read/Write	R/W	R/W	R/W	R/W	R/W	R/W	R/W	R/W
MDx[2]	Bit	7	6	5	4	3	2	1	0
		[] [] [] [] [] [] [] [] [] []							
	Initial value	*	*	*	*	*	*	*	*
	Read/Write	R/W	R/W	R/W	R/W	R/W	R/W	R/W	R/W
MDx[3]	Bit	7	6	5	4	3	2	1	0
		[] [] [] [] [] [] [] [] [] []							
	Initial value	*	*	*	*	*	*	*	*
	Read/Write	R/W	R/W	R/W	R/W	R/W	R/W	R/W	R/W
MDx[4]	Bit	7	6	5	4	3	2	1	0
		[] [] [] [] [] [] [] [] [] []							
	Initial value	*	*	*	*	*	*	*	*
	Read/Write	R/W	R/W	R/W	R/W	R/W	R/W	R/W	R/W
MDx[5]	Bit	7	6	5	4	3	2	1	0
		[] [] [] [] [] [] [] [] [] []							
	Initial value	*	*	*	*	*	*	*	*
	Read/Write	R/W	R/W	R/W	R/W	R/W	R/W	R/W	R/W
MDx[6]	Bit	7	6	5	4	3	2	1	0
		[] [] [] [] [] [] [] [] [] []							
	Initial value	*	*	*	*	*	*	*	*
	Read/Write	R/W	R/W	R/W	R/W	R/W	R/W	R/W	R/W
MDx[7]	Bit	7	6	5	4	3	2	1	0
		[] [] [] [] [] [] [] [] [] []							
	Initial value	*	*	*	*	*	*	*	*
	Read/Write	R/W	R/W	R/W	R/W	R/W	R/W	R/W	R/W
MDx[8]	Bit	7	6	5	4	3	2	1	0
		[] [] [] [] [] [] [] [] [] []							
	Initial value	*	*	*	*	*	*	*	*
	Read/Write	R/W	R/W	R/W	R/W	R/W	R/W	R/W	R/W

*: Undefined
x = 0 to 15

MD10[1]—Message Data 10[1]	H'FB00	HCAN1
MD10[2]—Message Data 10[2]	H'FB01	HCAN1
MD10[3]—Message Data 10[3]	H'FB02	HCAN1
MD10[4]—Message Data 10[4]	H'FB03	HCAN1
MD10[5]—Message Data 10[5]	H'FB04	HCAN1
MD10[6]—Message Data 10[6]	H'FB05	HCAN1
MD10[7]—Message Data 10[7]	H'FB06	HCAN1
MD10[8]—Message Data 10[8]	H'FB07	HCAN1

Note: These registers are not available in the H8S/2635 and H8S/2634.

MDx[1]	Bit	7	6	5	4	3	2	1	0
		[] [] [] [] [] [] [] [] [] []							
	Initial value	*	*	*	*	*	*	*	*
	Read/Write	R/W	R/W	R/W	R/W	R/W	R/W	R/W	R/W
MDx[2]	Bit	7	6	5	4	3	2	1	0
		[] [] [] [] [] [] [] [] [] []							
	Initial value	*	*	*	*	*	*	*	*
	Read/Write	R/W	R/W	R/W	R/W	R/W	R/W	R/W	R/W
MDx[3]	Bit	7	6	5	4	3	2	1	0
		[] [] [] [] [] [] [] [] [] []							
	Initial value	*	*	*	*	*	*	*	*
	Read/Write	R/W	R/W	R/W	R/W	R/W	R/W	R/W	R/W
MDx[4]	Bit	7	6	5	4	3	2	1	0
		[] [] [] [] [] [] [] [] [] []							
	Initial value	*	*	*	*	*	*	*	*
	Read/Write	R/W	R/W	R/W	R/W	R/W	R/W	R/W	R/W
MDx[5]	Bit	7	6	5	4	3	2	1	0
		[] [] [] [] [] [] [] [] [] []							
	Initial value	*	*	*	*	*	*	*	*
	Read/Write	R/W	R/W	R/W	R/W	R/W	R/W	R/W	R/W
MDx[6]	Bit	7	6	5	4	3	2	1	0
		[] [] [] [] [] [] [] [] [] []							
	Initial value	*	*	*	*	*	*	*	*
	Read/Write	R/W	R/W	R/W	R/W	R/W	R/W	R/W	R/W
MDx[7]	Bit	7	6	5	4	3	2	1	0
		[] [] [] [] [] [] [] [] [] []							
	Initial value	*	*	*	*	*	*	*	*
	Read/Write	R/W	R/W	R/W	R/W	R/W	R/W	R/W	R/W
MDx[8]	Bit	7	6	5	4	3	2	1	0
		[] [] [] [] [] [] [] [] [] []							
	Initial value	*	*	*	*	*	*	*	*
	Read/Write	R/W	R/W	R/W	R/W	R/W	R/W	R/W	R/W

*: Undefined
x = 0 to 15

MD11[1]—Message Data 11[1]	H'FB08	HCAN1
MD11[2]—Message Data 11[2]	H'FB09	HCAN1
MD11[3]—Message Data 11[3]	H'FB0A	HCAN1
MD11[4]—Message Data 11[4]	H'FB0B	HCAN1
MD11[5]—Message Data 11[5]	H'FB0C	HCAN1
MD11[6]—Message Data 11[6]	H'FB0D	HCAN1
MD11[7]—Message Data 11[7]	H'FB0E	HCAN1
MD11[8]—Message Data 11[8]	H'FB0F	HCAN1

Note: These registers are not available in the H8S/2635 and H8S/2634.

MDx[1]	Bit	7	6	5	4	3	2	1	0
		[] [] [] [] [] [] [] [] [] []							
	Initial value	*	*	*	*	*	*	*	*
	Read/Write	R/W	R/W	R/W	R/W	R/W	R/W	R/W	R/W
MDx[2]	Bit	7	6	5	4	3	2	1	0
		[] [] [] [] [] [] [] [] [] []							
	Initial value	*	*	*	*	*	*	*	*
	Read/Write	R/W	R/W	R/W	R/W	R/W	R/W	R/W	R/W
MDx[3]	Bit	7	6	5	4	3	2	1	0
		[] [] [] [] [] [] [] [] [] []							
	Initial value	*	*	*	*	*	*	*	*
	Read/Write	R/W	R/W	R/W	R/W	R/W	R/W	R/W	R/W
MDx[4]	Bit	7	6	5	4	3	2	1	0
		[] [] [] [] [] [] [] [] [] []							
	Initial value	*	*	*	*	*	*	*	*
	Read/Write	R/W	R/W	R/W	R/W	R/W	R/W	R/W	R/W
MDx[5]	Bit	7	6	5	4	3	2	1	0
		[] [] [] [] [] [] [] [] [] []							
	Initial value	*	*	*	*	*	*	*	*
	Read/Write	R/W	R/W	R/W	R/W	R/W	R/W	R/W	R/W
MDx[6]	Bit	7	6	5	4	3	2	1	0
		[] [] [] [] [] [] [] [] [] []							
	Initial value	*	*	*	*	*	*	*	*
	Read/Write	R/W	R/W	R/W	R/W	R/W	R/W	R/W	R/W
MDx[7]	Bit	7	6	5	4	3	2	1	0
		[] [] [] [] [] [] [] [] [] []							
	Initial value	*	*	*	*	*	*	*	*
	Read/Write	R/W	R/W	R/W	R/W	R/W	R/W	R/W	R/W
MDx[8]	Bit	7	6	5	4	3	2	1	0
		[] [] [] [] [] [] [] [] [] []							
	Initial value	*	*	*	*	*	*	*	*
	Read/Write	R/W	R/W	R/W	R/W	R/W	R/W	R/W	R/W

*: Undefined
x = 0 to 15

MD12[1]—Message Data 12[1]	H'FB10	HCAN1
MD12[2]—Message Data 12[2]	H'FB11	HCAN1
MD12[3]—Message Data 12[3]	H'FB12	HCAN1
MD12[4]—Message Data 12[4]	H'FB13	HCAN1
MD12[5]—Message Data 12[5]	H'FB14	HCAN1
MD12[6]—Message Data 12[6]	H'FB15	HCAN1
MD12[7]—Message Data 12[7]	H'FB16	HCAN1
MD12[8]—Message Data 12[8]	H'FB17	HCAN1

Note: These registers are not available in the H8S/2635 and H8S/2634.

MDx[1]	Bit	7	6	5	4	3	2	1	0
		[] [] [] [] [] [] [] [] [] []							
	Initial value	*	*	*	*	*	*	*	*
	Read/Write	R/W	R/W	R/W	R/W	R/W	R/W	R/W	R/W
MDx[2]	Bit	7	6	5	4	3	2	1	0
		[] [] [] [] [] [] [] [] [] []							
	Initial value	*	*	*	*	*	*	*	*
	Read/Write	R/W	R/W	R/W	R/W	R/W	R/W	R/W	R/W
MDx[3]	Bit	7	6	5	4	3	2	1	0
		[] [] [] [] [] [] [] [] [] []							
	Initial value	*	*	*	*	*	*	*	*
	Read/Write	R/W	R/W	R/W	R/W	R/W	R/W	R/W	R/W
MDx[4]	Bit	7	6	5	4	3	2	1	0
		[] [] [] [] [] [] [] [] [] []							
	Initial value	*	*	*	*	*	*	*	*
	Read/Write	R/W	R/W	R/W	R/W	R/W	R/W	R/W	R/W
MDx[5]	Bit	7	6	5	4	3	2	1	0
		[] [] [] [] [] [] [] [] [] []							
	Initial value	*	*	*	*	*	*	*	*
	Read/Write	R/W	R/W	R/W	R/W	R/W	R/W	R/W	R/W
MDx[6]	Bit	7	6	5	4	3	2	1	0
		[] [] [] [] [] [] [] [] [] []							
	Initial value	*	*	*	*	*	*	*	*
	Read/Write	R/W	R/W	R/W	R/W	R/W	R/W	R/W	R/W
MDx[7]	Bit	7	6	5	4	3	2	1	0
		[] [] [] [] [] [] [] [] [] []							
	Initial value	*	*	*	*	*	*	*	*
	Read/Write	R/W	R/W	R/W	R/W	R/W	R/W	R/W	R/W
MDx[8]	Bit	7	6	5	4	3	2	1	0
		[] [] [] [] [] [] [] [] [] []							
	Initial value	*	*	*	*	*	*	*	*
	Read/Write	R/W	R/W	R/W	R/W	R/W	R/W	R/W	R/W

*: Undefined
x = 0 to 15

MD13[1]—Message Data 13[1]	H'FB18	HCAN1
MD13[2]—Message Data 13[2]	H'FB19	HCAN1
MD13[3]—Message Data 13[3]	H'FB1A	HCAN1
MD13[4]—Message Data 13[4]	H'FB1B	HCAN1
MD13[5]—Message Data 13[5]	H'FB1C	HCAN1
MD13[6]—Message Data 13[6]	H'FB1D	HCAN1
MD13[7]—Message Data 13[7]	H'FB1E	HCAN1
MD13[8]—Message Data 13[8]	H'FB1F	HCAN1

Note: These registers are not available in the H8S/2635 and H8S/2634.

MDx[1]	Bit	7	6	5	4	3	2	1	0										
		<table border="1" style="width: 100%; height: 20px;"> <tr> <td style="width: 12.5%;"></td> <td style="width: 12.5%;"></td> <td style="width: 12.5%;"></td> <td style="width: 12.5%;"></td> <td style="width: 12.5%;"></td> <td style="width: 12.5%;"></td> <td style="width: 12.5%;"></td> <td style="width: 12.5%;"></td> <td style="width: 12.5%;"></td> <td style="width: 12.5%;"></td> </tr> </table>																	
	Initial value	*	*	*	*	*	*	*	*										
	Read/Write	R/W	R/W	R/W	R/W	R/W	R/W	R/W	R/W										
MDx[2]	Bit	7	6	5	4	3	2	1	0										
		<table border="1" style="width: 100%; height: 20px;"> <tr> <td style="width: 12.5%;"></td> <td style="width: 12.5%;"></td> <td style="width: 12.5%;"></td> <td style="width: 12.5%;"></td> <td style="width: 12.5%;"></td> <td style="width: 12.5%;"></td> <td style="width: 12.5%;"></td> <td style="width: 12.5%;"></td> <td style="width: 12.5%;"></td> <td style="width: 12.5%;"></td> </tr> </table>																	
	Initial value	*	*	*	*	*	*	*	*										
	Read/Write	R/W	R/W	R/W	R/W	R/W	R/W	R/W	R/W										
MDx[3]	Bit	7	6	5	4	3	2	1	0										
		<table border="1" style="width: 100%; height: 20px;"> <tr> <td style="width: 12.5%;"></td> <td style="width: 12.5%;"></td> <td style="width: 12.5%;"></td> <td style="width: 12.5%;"></td> <td style="width: 12.5%;"></td> <td style="width: 12.5%;"></td> <td style="width: 12.5%;"></td> <td style="width: 12.5%;"></td> <td style="width: 12.5%;"></td> <td style="width: 12.5%;"></td> </tr> </table>																	
	Initial value	*	*	*	*	*	*	*	*										
	Read/Write	R/W	R/W	R/W	R/W	R/W	R/W	R/W	R/W										
MDx[4]	Bit	7	6	5	4	3	2	1	0										
		<table border="1" style="width: 100%; height: 20px;"> <tr> <td style="width: 12.5%;"></td> <td style="width: 12.5%;"></td> <td style="width: 12.5%;"></td> <td style="width: 12.5%;"></td> <td style="width: 12.5%;"></td> <td style="width: 12.5%;"></td> <td style="width: 12.5%;"></td> <td style="width: 12.5%;"></td> <td style="width: 12.5%;"></td> <td style="width: 12.5%;"></td> </tr> </table>																	
	Initial value	*	*	*	*	*	*	*	*										
	Read/Write	R/W	R/W	R/W	R/W	R/W	R/W	R/W	R/W										
MDx[5]	Bit	7	6	5	4	3	2	1	0										
		<table border="1" style="width: 100%; height: 20px;"> <tr> <td style="width: 12.5%;"></td> <td style="width: 12.5%;"></td> <td style="width: 12.5%;"></td> <td style="width: 12.5%;"></td> <td style="width: 12.5%;"></td> <td style="width: 12.5%;"></td> <td style="width: 12.5%;"></td> <td style="width: 12.5%;"></td> <td style="width: 12.5%;"></td> <td style="width: 12.5%;"></td> </tr> </table>																	
	Initial value	*	*	*	*	*	*	*	*										
	Read/Write	R/W	R/W	R/W	R/W	R/W	R/W	R/W	R/W										
MDx[6]	Bit	7	6	5	4	3	2	1	0										
		<table border="1" style="width: 100%; height: 20px;"> <tr> <td style="width: 12.5%;"></td> <td style="width: 12.5%;"></td> <td style="width: 12.5%;"></td> <td style="width: 12.5%;"></td> <td style="width: 12.5%;"></td> <td style="width: 12.5%;"></td> <td style="width: 12.5%;"></td> <td style="width: 12.5%;"></td> <td style="width: 12.5%;"></td> <td style="width: 12.5%;"></td> </tr> </table>																	
	Initial value	*	*	*	*	*	*	*	*										
	Read/Write	R/W	R/W	R/W	R/W	R/W	R/W	R/W	R/W										
MDx[7]	Bit	7	6	5	4	3	2	1	0										
		<table border="1" style="width: 100%; height: 20px;"> <tr> <td style="width: 12.5%;"></td> <td style="width: 12.5%;"></td> <td style="width: 12.5%;"></td> <td style="width: 12.5%;"></td> <td style="width: 12.5%;"></td> <td style="width: 12.5%;"></td> <td style="width: 12.5%;"></td> <td style="width: 12.5%;"></td> <td style="width: 12.5%;"></td> <td style="width: 12.5%;"></td> </tr> </table>																	
	Initial value	*	*	*	*	*	*	*	*										
	Read/Write	R/W	R/W	R/W	R/W	R/W	R/W	R/W	R/W										
MDx[8]	Bit	7	6	5	4	3	2	1	0										
		<table border="1" style="width: 100%; height: 20px;"> <tr> <td style="width: 12.5%;"></td> <td style="width: 12.5%;"></td> <td style="width: 12.5%;"></td> <td style="width: 12.5%;"></td> <td style="width: 12.5%;"></td> <td style="width: 12.5%;"></td> <td style="width: 12.5%;"></td> <td style="width: 12.5%;"></td> <td style="width: 12.5%;"></td> <td style="width: 12.5%;"></td> </tr> </table>																	
	Initial value	*	*	*	*	*	*	*	*										
	Read/Write	R/W	R/W	R/W	R/W	R/W	R/W	R/W	R/W										

*: Undefined
x = 0 to 15

MD14[1]—Message Data 14[1]	H'FB20	HCAN1
MD14[2]—Message Data 14[2]	H'FB21	HCAN1
MD14[3]—Message Data 14[3]	H'FB22	HCAN1
MD14[4]—Message Data 14[4]	H'FB23	HCAN1
MD14[5]—Message Data 14[5]	H'FB24	HCAN1
MD14[6]—Message Data 14[6]	H'FB25	HCAN1
MD14[7]—Message Data 14[7]	H'FB26	HCAN1
MD14[8]—Message Data 14[8]	H'FB27	HCAN1

Note: These registers are not available in the H8S/2635 and H8S/2634.

MDx[1] Bit	7	6	5	4	3	2	1	0
	<input type="checkbox"/>	<input type="checkbox"/>	<input type="checkbox"/>	<input type="checkbox"/>	<input type="checkbox"/>	<input type="checkbox"/>	<input type="checkbox"/>	<input type="checkbox"/>
Initial value	*	*	*	*	*	*	*	*
Read/Write	R/W	R/W	R/W	R/W	R/W	R/W	R/W	R/W
MDx[2] Bit	7	6	5	4	3	2	1	0
	<input type="checkbox"/>	<input type="checkbox"/>	<input type="checkbox"/>	<input type="checkbox"/>	<input type="checkbox"/>	<input type="checkbox"/>	<input type="checkbox"/>	<input type="checkbox"/>
Initial value	*	*	*	*	*	*	*	*
Read/Write	R/W	R/W	R/W	R/W	R/W	R/W	R/W	R/W
MDx[3] Bit	7	6	5	4	3	2	1	0
	<input type="checkbox"/>	<input type="checkbox"/>	<input type="checkbox"/>	<input type="checkbox"/>	<input type="checkbox"/>	<input type="checkbox"/>	<input type="checkbox"/>	<input type="checkbox"/>
Initial value	*	*	*	*	*	*	*	*
Read/Write	R/W	R/W	R/W	R/W	R/W	R/W	R/W	R/W
MDx[4] Bit	7	6	5	4	3	2	1	0
	<input type="checkbox"/>	<input type="checkbox"/>	<input type="checkbox"/>	<input type="checkbox"/>	<input type="checkbox"/>	<input type="checkbox"/>	<input type="checkbox"/>	<input type="checkbox"/>
Initial value	*	*	*	*	*	*	*	*
Read/Write	R/W	R/W	R/W	R/W	R/W	R/W	R/W	R/W
MDx[5] Bit	7	6	5	4	3	2	1	0
	<input type="checkbox"/>	<input type="checkbox"/>	<input type="checkbox"/>	<input type="checkbox"/>	<input type="checkbox"/>	<input type="checkbox"/>	<input type="checkbox"/>	<input type="checkbox"/>
Initial value	*	*	*	*	*	*	*	*
Read/Write	R/W	R/W	R/W	R/W	R/W	R/W	R/W	R/W
MDx[6] Bit	7	6	5	4	3	2	1	0
	<input type="checkbox"/>	<input type="checkbox"/>	<input type="checkbox"/>	<input type="checkbox"/>	<input type="checkbox"/>	<input type="checkbox"/>	<input type="checkbox"/>	<input type="checkbox"/>
Initial value	*	*	*	*	*	*	*	*
Read/Write	R/W	R/W	R/W	R/W	R/W	R/W	R/W	R/W
MDx[7] Bit	7	6	5	4	3	2	1	0
	<input type="checkbox"/>	<input type="checkbox"/>	<input type="checkbox"/>	<input type="checkbox"/>	<input type="checkbox"/>	<input type="checkbox"/>	<input type="checkbox"/>	<input type="checkbox"/>
Initial value	*	*	*	*	*	*	*	*
Read/Write	R/W	R/W	R/W	R/W	R/W	R/W	R/W	R/W
MDx[8] Bit	7	6	5	4	3	2	1	0
	<input type="checkbox"/>	<input type="checkbox"/>	<input type="checkbox"/>	<input type="checkbox"/>	<input type="checkbox"/>	<input type="checkbox"/>	<input type="checkbox"/>	<input type="checkbox"/>
Initial value	*	*	*	*	*	*	*	*
Read/Write	R/W	R/W	R/W	R/W	R/W	R/W	R/W	R/W

*: Undefined
x = 0 to 15

MD15[1]—Message Data 15[1]	H'FB28	HCAN1
MD15[2]—Message Data 15[2]	H'FB29	HCAN1
MD15[3]—Message Data 15[3]	H'FB2A	HCAN1
MD15[4]—Message Data 15[4]	H'FB2B	HCAN1
MD15[5]—Message Data 15[5]	H'FB2C	HCAN1
MD15[6]—Message Data 15[6]	H'FB2D	HCAN1
MD15[7]—Message Data 15[7]	H'FB2E	HCAN1
MD15[8]—Message Data 15[8]	H'FB2F	HCAN1

Note: These registers are not available in the H8S/2635 and H8S/2634.

MDx[1]	Bit	7	6	5	4	3	2	1	0
		[][][][][][][][][]							
	Initial value	*	*	*	*	*	*	*	*
	Read/Write	R/W	R/W	R/W	R/W	R/W	R/W	R/W	R/W
MDx[2]	Bit	7	6	5	4	3	2	1	0
		[][][][][][][][][]							
	Initial value	*	*	*	*	*	*	*	*
	Read/Write	R/W	R/W	R/W	R/W	R/W	R/W	R/W	R/W
MDx[3]	Bit	7	6	5	4	3	2	1	0
		[][][][][][][][][]							
	Initial value	*	*	*	*	*	*	*	*
	Read/Write	R/W	R/W	R/W	R/W	R/W	R/W	R/W	R/W
MDx[4]	Bit	7	6	5	4	3	2	1	0
		[][][][][][][][][]							
	Initial value	*	*	*	*	*	*	*	*
	Read/Write	R/W	R/W	R/W	R/W	R/W	R/W	R/W	R/W
MDx[5]	Bit	7	6	5	4	3	2	1	0
		[][][][][][][][][]							
	Initial value	*	*	*	*	*	*	*	*
	Read/Write	R/W	R/W	R/W	R/W	R/W	R/W	R/W	R/W
MDx[6]	Bit	7	6	5	4	3	2	1	0
		[][][][][][][][][]							
	Initial value	*	*	*	*	*	*	*	*
	Read/Write	R/W	R/W	R/W	R/W	R/W	R/W	R/W	R/W
MDx[7]	Bit	7	6	5	4	3	2	1	0
		[][][][][][][][][]							
	Initial value	*	*	*	*	*	*	*	*
	Read/Write	R/W	R/W	R/W	R/W	R/W	R/W	R/W	R/W
MDx[8]	Bit	7	6	5	4	3	2	1	0
		[][][][][][][][][]							
	Initial value	*	*	*	*	*	*	*	*
	Read/Write	R/W	R/W	R/W	R/W	R/W	R/W	R/W	R/W

*: Undefined
x = 0 to 15

PWCR1—PWM Control Register 1

H'FC00

PWM1

Bit	7	6	5	4	3	2	1	0
	—	—	IE	CMF	CST	CKS2	CKS1	CKS0
Initial value	1	1	0	0	0	0	0	0
Read/Write	—	—	R/W	R/(W)*	R/W	R/W	R/W	R/W

Clock Select

0	0	0	Internal clock: counts on $\phi/1$
	1	1	Internal clock: counts on $\phi/2$
1	0	0	Internal clock: counts on $\phi/4$
	1	1	Internal clock: counts on $\phi/8$
1	*	*	Internal clock: counts on $\phi/16$

*: Don't care

Counter Start

0	PWCNT is stopped
1	PWCNT is started

Compare Match Flag

0	[Clearing conditions] <ul style="list-style-type: none"> When 0 is written to CMF after reading CMF = 1 When the DTC is activated by a compare match interrupt, and the DISEL bit in the DTC's MRB register is 0
1	[Setting condition] <ul style="list-style-type: none"> When PWCNT = PWCYR

Interrupt Enable

0	Interrupt disabled
1	Interrupt enabled

Note: * Only 0 can be written, to clear the flag.

PWOCR1—PWM Output Control Register 1 **H'FC02** **PWM1**

Bit	7	6	5	4	3	2	1	0
	OE1H	OE1G	OE1F	OE1E	OE1D	OE1C	OE1B	OE1A
Initial value	0	0	0	0	0	0	0	0
Read/Write	R/W	R/W	R/W	R/W	R/W	R/W	R/W	R/W

Output Enable

0	PWM output is disabled
1	PWM output is enabled

PWPR1—PWM Polarity Register 1 **H'FC04** **PWM1**

Bit	7	6	5	4	3	2	1	0
	OPS1H	OPS1G	OPS1F	OPS1E	OPS1D	OPS1C	OPS1B	OPS1A
Initial value	0	0	0	0	0	0	0	0
Read/Write	R/W	R/W	R/W	R/W	R/W	R/W	R/W	R/W

Output Polarity Select

0	PWM direct output
1	PWM inverse output

PWCYR1—PWM Cycle Register 1 **H'FC06** **PWM1**

Bit	15	14	13	12	11	10	9	8	7	6	5	4	3	2	1	0
	—	—	—	—	—	—										
Initial value	1	1	1	1	1	1	1	1	1	1	1	1	1	1	1	1
Read/Write	—	—	—	—	—	—	R/W	R/W	R/W	R/W	R/W	R/W	R/W	R/W	R/W	R/W

Set the PWM conversion cycle

PWBFR1A—PWM Buffer Register 1A	H'FC08	PWM1
PWBFR1C—PWM Buffer Register 1C	H'FC0A	PWM1
PWBFR1E—PWM Buffer Register 1E	H'FC0C	PWM1
PWBFR1G—PWM Buffer Register 1G	H'FC0E	PWM1

Bit	15	14	13	12	11	10	9	8	7	6	5	4	3	2	1	0
	—	—	—	OTS	—	—	DT9	DT8	DT7	DT6	DT5	DT4	DT3	DT2	DT1	DT0
Initial value	1	1	1	0	1	1	0	0	0	0	0	0	0	0	0	0
Read/Write	—	—	—	R/W	—	—	R/W	R/W	R/W	R/W	R/W	R/W	R/W	R/W	R/W	R/W

Output Terminal Select

Bit 12 is the data transferred to bit 12 of PWDTR1

Duty

Bits 9 to 0 comprise the data transferred to bits 9 to 0 in PWDTR1

Register	OTS	Description
PWDTR1A	0	PWM1A output selected
	1	PWM1B output selected
PWDTR1C	0	PWM1C output selected
	1	PWM1D output selected
PWDTR1E	0	PWM1E output selected
	1	PWM1F output selected
PWDTR1G	0	PWM1G output selected
	1	PWM1H output selected

Note: When a PWCYR1 compare match occurs, data is transferred from PWBFR1A to PWDTR1A, from PWBFR1C to PWDTR1C, from PWBFR1E to PWDTR1E, and from PWBFR1G to PWDTR1G.

PWCR2—PWM Control Register 2

H'FC10

PWM2

Bit	7	6	5	4	3	2	1	0
	—	—	IE	CMF	CST	CKS2	CKS1	CKS0
Initial value	1	1	0	0	0	0	0	0
Read/Write	—	—	R/W	R/(W)*	R/W	R/W	R/W	R/W

Clock Select

0	0	0	Internal clock: counts on $\phi/1$
		1	Internal clock: counts on $\phi/2$
1	0	0	Internal clock: counts on $\phi/4$
		1	Internal clock: counts on $\phi/8$
1	*	*	Internal clock: counts on $\phi/16$

*: Don't care

Counter Start

0	PWCNT is stopped
1	PWCNT is started

Compare Match Flag

0	[Clearing conditions] <ul style="list-style-type: none"> When 0 is written to CMF after reading CMF = 1 When the DTC is activated by a compare match interrupt, and the DISSEL bit in the DTC's MRB register is 0
1	[Setting condition] <ul style="list-style-type: none"> When PWCNT = PWCYR

Interrupt Enable

0	Interrupt disabled
1	Interrupt enabled

Note: * Only 0 can be written, to clear the flag.

PWOCR2—PWM Output Control Register 2**H'FC12****PWM2**

Bit	7	6	5	4	3	2	1	0
	OE2H	OE2G	OE2F	OE2E	OE2D	OE2C	OE2B	OE2A
Initial value	0	0	0	0	0	0	0	0
Read/Write	R/W	R/W	R/W	R/W	R/W	R/W	R/W	R/W

Output Enable

0	PWM output is disabled
1	PWM output is enabled

PWPR2—PWM Polarity Register 2**H'FC14****PWM2**

Bit	7	6	5	4	3	2	1	0
	OPS2H	OPS2G	OPS2F	OPS2E	OPS2D	OPS2C	OPS2B	OPS2A
Initial value	0	0	0	0	0	0	0	0
Read/Write	R/W	R/W	R/W	R/W	R/W	R/W	R/W	R/W

Output Polarity Select

0	PWM direct output
1	PWM inverse output

PWCYR2—PWM Cycle Register 2**H'FC16****PWM2**

Bit	15	14	13	12	11	10	9	8	7	6	5	4	3	2	1	0
	—	—	—	—	—	—										
Initial value	1	1	1	1	1	1	1	1	1	1	1	1	1	1	1	1
Read/Write	—	—	—	—	—	—	R/W	R/W	R/W	R/W	R/W	R/W	R/W	R/W	R/W	R/W

Set the PWM conversion cycle

PWBFR2A—PWM Buffer Register 2A	H'FC18	PWM2
PWBFR2B—PWM Buffer Register 2B	H'FC1A	PWM2
PWBFR2C—PWM Buffer Register 2C	H'FC1C	PWM2
PWBFR2D—PWM Buffer Register 2D	H'FC1E	PWM2

Bit	15	14	13	12	11	10	9	8	7	6	5	4	3	2	1	0
	—	—	—	TDS	—	—	DT9	DT8	DT7	DT6	DT5	DT4	DT3	DT2	DT1	DT0
Initial value	1	1	1	0	1	1	0	0	0	0	0	0	0	0	0	0
Read/Write	—	—	—	R/W	—	—	R/W	R/W	R/W	R/W	R/W	R/W	R/W	R/W	R/W	R/W

Duty _____
 Bits 9 to 0 compromise the data transferred to bits 9 to 0 in PWDTR2

Transfer Destination Select

Selects the PWDTR2 register to which data is to be transferred

Register	TDS	Description
PWBFR2A	0	PWDTR2A selected
	1	PWDTR2E selected
PWBFR2B	0	PWDTR2B selected
	1	PWDTR2F selected
PWBFR2C	0	PWDTR2C selected
	1	PWDTR2G selected
PWBFR2D	0	PWDTR2D selected
	1	PWDTR2H selected

Note: When a PWCYR2 compare match occurs, data is transferred from PWBFR2A to PWDTR2A or PWDTR2E, from PWBFR2B to PWDTR2B or PWDTR2F, from PWBFR2C to PWDTR2C or PWDTR2G, and from PWBFR2D to PWDTR2D or PWDTR2H.

PHDDR—Port H Data Direction Register	H'FC20	Port
---	---------------	-------------

Bit	7	6	5	4	3	2	1	0
	PH7DDR	PH6DDR	PH5DDR	PH4DDR	PH3DDR	PH2DDR	PH1DDR	PH0DDR
Initial value	0	0	0	0	0	0	0	0
Read/Write	W	W	W	W	W	W	W	W

PJDDR—Port J Data Direction Register **H'FC21** **Port**

Bit	7	6	5	4	3	2	1	0
	PJ7DDR	PJ6DDR	PJ5DDR	PJ4DDR	PJ3DDR	PJ2DDR	PJ1DDR	PJ0DDR
Initial value	0	0	0	0	0	0	0	0
Read/Write	W	W	W	W	W	W	W	W

PHDR—Port H Data Register **H'FC24** **Port**

Bit	7	6	5	4	3	2	1	0
	PH7DR	PH6DR	PH5DR	PH4DR	PH3DR	PH2DR	PH1DR	PH0DR
Initial value	0	0	0	0	0	0	0	0
Read/Write	R/W	R/W	R/W	R/W	R/W	R/W	R/W	R/W

PJDR—Port J Data Register **H'FC25** **Port**

Bit	7	6	5	4	3	2	1	0
	PJ7DR	PJ6DR	PJ5DR	PJ4DR	PJ3DR	PJ2DR	PJ1DR	PJ0DR
Initial value	0	0	0	0	0	0	0	0
Read/Write	R/W	R/W	R/W	R/W	R/W	R/W	R/W	R/W

PORTH—Port H Register **H'FC28** **Port**

Bit	7	6	5	4	3	2	1	0
	PH7	PH6	PH5	PH4	PH3	PH2	PH1	PH0
Initial value	—*	—*	—*	—*	—*	—*	—*	—*
Read/Write	R	R	R	R	R	R	R	R

Note: * Determined by the state of PH7 to PH0.

PORTJ—Port J Register **H'FC29** **Port**

Bit	7	6	5	4	3	2	1	0
	PJ7	PJ6	PJ5	PJ4	PJ3	PJ2	PJ1	PJ0
Initial value	—*	—*	—*	—*	—*	—*	—*	—*
Read/Write	R	R	R	R	R	R	R	R

Note: * Determined by the state of PJ7 to PJ0.

MSTPCRD—Module Stop Control Register D **H'FC60** **System**

Bit	7	6	5	4	3	2	1	0
	MSTPD7	MSTPD6	MSTPD5	MSTPD4	MSTPD3	MSTPD2	MSTPD1	MSTPD0
Initial value	1	1	Undefined	Undefined	Undefined	Undefined	Undefined	Undefined
Read/Write	R/W	R/W	—	—	—	—	—	—

Module Stop

0	PWM module stop mode is cleared
1	PWM module stop mode is set

SCRX—Serial Control Register X **H'FDB4** **IIC**

Bit	7	6	5	4	3	2	1	0
	—	IICX1	IICX0	IICE	—	—	—	—
Initial value	0	0	0	0	1	0	0	0
R/W	R/W	R/W	R/W	R/W	—	R/W	R/W	R/W

I²C master enable

0	Disables CPU access of I ² C bus interface data register and control register
1	Enables CPU access of I ² C bus interface data register and control register

I²C transfer rate select 1, 0

Note: This register is valid only when an I²C bus interface has been added as an H8S/2638, H8S/2639, and H8S/2630 option.

DDCSWR—DDC Switch Register

H'FDB5

IIC

Bit	:	7	6	5	4	3	2	1	0
		—	—	—	—	CLR3	CLR2	CLR1	CLR0
Initial value	:	0	0	0	0	1	1	1	1
R/W	:	R/(W)*1	R/(W)*1	R/(W)*1	R/(W)*1	W*2	W*2	W*2	W*2

Reserved bit

IIC clear 3 to 0

CLR3	CLR2	CLR1	CLR0	
0	0	—	—	Setting prohibited
		0	0	Setting prohibited
	1	0	1	IIC0 internal latch cleared
		1	0	IIC1 internal latch cleared
1	—	—	1	IIC0 and IIC1 internal latches cleared
			—	—

Notes: This register is valid only when an I²C bus interface has been added as an H8S/2638, H8S/2639, and H8S/2630 option.

1. Should always be written with 0.
2. Always read as 1.

SBYCR—Standby Control Register

H'FDE4

System

Bit	7	6	5	4	3	2	1	0
	SSBY	STS2	STS1	STS0	OPE	—	—	—
Initial value	0	1	0	1	1	0	0	0
Read/Write	R/W	R/W	R/W	R/W	R/W	—	—	—

Output Port Enable

0	In software standby mode, watch mode, and when making a direct transition, address bus and bus control signals are high-impedance
1	In software standby mode, watch mode, and when making a direct transition, the output state of the address bus and bus control signals is retained

Standby Timer Select 2 to 0

0	0	0	Standby time = 8192 states
		1	Standby time = 16384 states
	1	0	Standby time = 32768 states
		1	Standby time = 65536 states
1	0	0	Standby time = 131072 states
		1	Standby time = 262144 states
	1	0	Reserved
		1	Standby time = 16 states (Setting prohibited)

Software Standby

0	<ul style="list-style-type: none"> Shifts to sleep mode when the SLEEP instruction is executed in high-speed mode or medium-speed mode Shifts to sub-sleep mode when the SLEEP instruction is executed in sub-active mode
1	<ul style="list-style-type: none"> Shifts to software standby mode, sub-active mode, and watch mode when the SLEEP instruction is executed in high-speed mode or medium-speed mode Shifts to watch mode or high-speed mode when the SLEEP instruction is executed in sub-active mode

SYSCR—System Control Register

H'FDE5

System

Bit	7	6	5	4	3	2	1	0
	MACS	—	INTM1	INTM0	NMIEG	—	—	RAME
Initial value	0	0	0	0	0	0	0	1
Read/Write	R/W	—	R/W	R/W	R/W	—	—	R/W

RAM Enable

0	On-chip RAM is disabled
1	On-chip RAM is enabled

NMI Edge Select

0	An interrupt is requested at the falling edge of NMI input
1	An interrupt is requested at the rising edge of NMI input

Interrupt Control Mode 1 and 0

INTM1	INTM0	Interrupt Control Mode	Description
0	0	0	Control of interrupts by I bit
	1	—	Setting prohibited
1	0	2	Control of interrupts by I2 to I0 bits and IPR
	1	—	Setting prohibited

MAC Saturation

0	Non-saturating calculation for MAC instruction
1	Saturating calculation for MAC instruction

SCKCR—System Clock Control Register

H'FDE6

System

Bit	7	6	5	4	3	2	1	0
	PSTOP	—	—	—	STCS	SCK2	SCK1	SCK0
Initial value	0	0	0	0	0	0	0	0
Read/Write	R/W	—	—	—	R/W	R/W	R/W	R/W

System Clock Select

0	0	0	Bus master in high-speed mode
		1	Medium-speed clock is $\phi/2$
1	0	0	Medium-speed clock is $\phi/4$
		1	Medium-speed clock is $\phi/8$
1	0	0	Medium-speed clock is $\phi/16$
		1	Medium-speed clock is $\phi/32$
	1	—	—

Frequency Multiplication Factor Switching Mode Select

0	Specified multiplication factor is valid after transition to software standby mode, watch mode*, or subactive mode*
1	Specified multiplication factor is valid immediately after STC bits are rewritten

 ϕ Clock Output Disable

DDR	0	1	1
PSTOP	—	0	1
Hardware standby mode	High impedance	High impedance	High impedance
Software standby mode, watch mode*, and direct transition	High impedance	Fixed high	Fixed high
Sleep mode and subsleep mode*	High impedance	ϕ output	Fixed high
High-speed mode, medium-speed mode, and subactive mode*	High impedance	ϕ output	Fixed high

Note: * Subclock functions (subactive mode, subsleep mode, and watch mode) are available in the U-mask and W-mask versions, and H8S/2635 Group only. These functions cannot be used with the other versions.

MDCR—Mode Control Register**H'FDE7****System**

Bit	7	6	5	4	3	2	1	0
	—	—	—	—	—	MDS2	MDS1	MDS0
Initial value	1	0	0	0	0	—*	—*	—*
Read/Write	R/W	—	—	—	—	R	R	R

Mode Select 2 to 0
Indicate the input levels at
pins MD2 to MD0

Note: * Determined by pins MD2 to MD0.

MSTPCRA—Module Stop Control Register A**H'FDE8****System**

Bit	7	6	5	4	3	2	1	0
	MSTPA7	MSTPA6	MSTPA5	MSTPA4	MSTPA3	MSTPA2	MSTPA1	MSTPA0
Initial value	0	0	1	1	1	1	1	1
Read/Write	R/W	R/W	R/W	R/W	R/W	R/W	R/W	R/W

Module Stop

0	Module stop mode is cleared
1	Module stop mode is set

MSTPCRB—Module Stop Control Register B**H'FDE9****System**

Bit	7	6	5	4	3	2	1	0
	MSTPB7	MSTPB6	MSTPB5	MSTPB4	MSTPB3	MSTPB2	MSTPB1	MSTPB0
Initial value	1	1	1	1	1	1	1	1
Read/Write	R/W	R/W	R/W	R/W	R/W	R/W	R/W	R/W

Module Stop

0	Module stop mode is cleared
1	Module stop mode is set

MSTPCRC—Module Stop Control Register C**H'FDEA****System**

Bit	7	6	5	4	3	2	1	0
	MSTPC7	MSTPC6	MSTPC5	MSTPC4	MSTPC3	MSTPC2	MSTPC1	MSTPC0
Initial value	1	1	1	1	1	1	1	1
Read/Write	R/W	R/W	R/W	R/W	R/W	R/W	R/W	R/W

Module Stop

0	Module stop mode is cleared
1	Module stop mode is set

PFCR—Pin Function Control Register**H'FDEB****System**

Bit	7	6	5	4	3	2	1	0
	—	—	—	—	AE3	AE2	AE1	AE0
Initial value	0	0	0	0	1/0	1/0	1	1/0
Read/Write	—	—	—	—	R/W	R/W	R/W	R/W

Address Output Enable 3 to 0

0	0	0	0	A8 to A23 address output disabled
		1	A8 address output enabled; A9 to A23 address output disabled	
		1	0	A8, A9 address output enabled; A10 to A23 address output disabled
			1	A8 to A10 address output enabled; A11 to A23 address output disabled
	1	0	0	A8 to A11 address output enabled; A12 to A23 address output disabled
			1	A8 to A12 address output enabled; A13 to A23 address output disabled
		1	0	A8 to A13 address output enabled; A14 to A23 address output disabled
			1	A8 to A14 address output enabled; A15 to A23 address output disabled
1	0	0	A8 to A15 address output enabled; A16 to A23 address output disabled	
		1	A8 to A16 address output enabled; A17 to A23 address output disabled	
		1	0	A8 to A17 address output enabled; A18 to A23 address output disabled
			1	A8 to A18 address output enabled; A19 to A23 address output disabled
	1	0	0	A8 to A19 address output enabled; A20 to A23 address output disabled
			1	A8 to A20 address output enabled; A21 to A23 address output disabled (Initial value*)
		1	0	A8 to A21 address output enabled; A22, A23 address output disabled
			1	A8 to A23 address output enabled

Note: * In on-chip ROM-enabled expansion mode, bits AE3 to AE0 are initialized to B'0000.
 In on-chip ROM-disabled expansion mode, bits AE3 to AE0 are initialized to B'1101.
 Address pins A0 to A7 are made address outputs by setting the corresponding DDR bits to 1.

LPWRCR—Low-Power Control Register

H'FDEC

System

Bit	7	6	5	4	3	2	1	0
	DTON*1	LSON*1	NESEL*1	SUBSTP*1	RFCUT*1	—	STC1	STC0
Initial value	0	0	0	0	0	0	0	0
Read/Write	R/W	R/W	R/W	R/W	R/W	R/W	R/W	R/W

Frequency Multiplication Factor		
0	0	×1
	1	×2
1	0	×4
	1	Setting prohibited

Oscillation Circuit Feedback Resistance Control Bit	
0	When the main clock is oscillating, sets the feedback resistance ON. When the main clock is stopped, sets the feedback resistance OFF
1	Sets the feedback resistance OFF

Subclock Enable	
0	Enables subclock generation
1	Disables subclock generation

Noise Elimination Sampling Frequency Select	
0	Sampling using $1/32 \times \phi$
1	Sampling using $1/4 \times \phi$

Low-Speed ON Flag	
0	<ul style="list-style-type: none"> When the SLEEP instruction is executed in high-speed mode or medium-speed mode, operation shifts to sleep mode, software standby mode, or watch mode* When the SLEEP instruction is executed in sub-active mode, operation shifts to watch mode or shifts directly to high-speed mode Operation shifts to high-speed mode when watch mode is cancelled
1	<ul style="list-style-type: none"> When the SLEEP instruction is executed in high-speed mode, operation shifts to watch mode or sub-active mode When the SLEEP instruction is executed in sub-active mode, operation shifts to sub-sleep mode or watch mode Operation shifts to sub-active mode when watch mode is cancelled

Note: * Always set high-speed mode when shifting to watch mode or sub-active mode.

Direct Transition ON Flag

0	<ul style="list-style-type: none"> When the SLEEP instruction is executed in high-speed mode or medium-speed mode, operation shifts to sleep mode, software standby mode, or watch mode* When the SLEEP instruction is executed in sub-active mode, operation shifts to sub-sleep mode or watch mode
1	<ul style="list-style-type: none"> When the SLEEP instruction is executed in high-speed mode or medium-speed mode, operation shifts directly to sub-active mode*, or shifts to sleep mode or software standby mode When the SLEEP instruction is executed in sub-active mode, operation shifts directly to high-speed mode, or shifts to sub-sleep mode

Note: * Always set high-speed mode when shifting to watch mode or sub-active mode.

Note: 1. Bits 7 to 3 in LPWRCR are valid in the U-mask and W-mask versions, and H8S/2635 Group; they are reserved bits in all other versions.

See sections 23A.2.3, 23B.2.3, Low-Power Control Register (LPWRCR), for more information.

BARA—Break Address Register A**H'FE00****PBC****BARB—Break Address Register B****H'FE04****PBC**

Bit	31	...	24	23	22	21	20	19	18	17	16	...	7	6	5	4	3	2	1	0
	—	...	—	BAA 23	BAA 22	BAA 21	BAA 20	BAA 19	BAA 18	BAA 17	BAA 16	...	BAA 7	BAA 6	BAA 5	BAA 4	BAA 3	BAA 2	BAA 1	BAA 0
Initial value	Unde- fined	...	Unde- fined	0	0	0	0	0	0	0	0	...	0	0	0	0	0	0	0	0
Read/Write	—	...	—	R/W	R/W	R/W	R/W	R/W	R/W	R/W	R/W	...	R/W	R/W	R/W	R/W	R/W	R/W	R/W	R/W

Break Address 23 to 0
Specify the channel A or B break address

- Notes: 1. The bit configuration of BARB is the same as for BARA.
2. These registers are not available in the H8S/2635 and H8S/2634.

BCRA—Break Control Register A**H'FE08****PBC****BCRB—Break Control Register B****H'FE09****PBC**

Bit	7	6	5	4	3	2	1	0
	CMFA	CDA	BAMRA2	BAMRA1	BAMRA0	CSELA1	CSELA0	BIEA
Initial value	0	0	0	0	0	0	0	0
Read/Write	R/(W)*	R/W	R/W	R/W	R/W	R/W	R/W	R/W

Break Interrupt Enable

0	PC break interrupts are disabled
1	PC break interrupts are enabled

Break Condition Select

0	0	Instruction fetch is used as break condition
	1	Data read cycle is used as break condition
1	0	Data write cycle is used as break condition
	1	Data read/write cycle is used as break condition

Break Address Mask Register

0	0	All BARA bits are unmasked and included in break conditions
	1	BAA0 (lowest bit) is masked, and not included in break conditions
1	0	BAA1, BAA0 (lower 2 bits) are masked, and not included in break conditions
	1	BAA2 to BAA0 (lower 3 bits) are masked, and not included in break conditions
1	0	BAA3 to BAA0 (lower 4 bits) are masked, and not included in break conditions
	1	BAA7 to BAA0 (lower 8 bits) are masked, and not included in break conditions
1	0	BAA11 to BAA0 (lower 12 bits) are masked, and not included in break conditions
	1	BAA15 to BAA0 (lower 16 bits) are masked, and not included in break conditions

CPU Cycle/DTC Cycle Select A

0	PC break is performed when CPU is bus master
1	PC break is performed when CPU or DTC is bus master

Condition Match Flag A

0	[Clearing condition] • When 0 is written to CMFA after reading CMFA = 1
1	[Setting condition] • When a condition set for channel A is satisfied

- Notes: 1. The bit configuration of BCRB is the same as for BCRA.
 2. These registers are not available in the H8S/2635 and H8S/2634.
 * Only a 0 may be written to this bit to clear the flag.

ISCRH—IRQ Sence Control Register H**H'FE12****Interrupt Controller****ISCR L—IRQ Sence Control Register L****H'FE13****Interrupt Controller**

ISCRH

Bit	15	14	13	12	11	10	9	8
	—	—	—	—	IRQ5SCB	IRQ5SCA	IRQ4SCB	IRQ4SCA
Initial value	0	0	0	0	0	0	0	0
Read/Write	R/W	R/W	R/W	R/W	R/W	R/W	R/W	R/W

ISCR L

Bit	7	6	5	4	3	2	1	0
	IRQ3SCB	IRQ3SCA	IRQ2SCB	IRQ2SCA	IRQ1SCB	IRQ1SCA	IRQ0SCB	IRQ0SCA
Initial value	0	0	0	0	0	0	0	0
Read/Write	R/W	R/W	R/W	R/W	R/W	R/W	R/W	R/W

IRQ5 to IRQ0 sense control A and B

IRQ5SCB to IRQ0SCB	IRQ5SCA to IRQ0SCA	Description
0	0	Interrupt request generated at $\overline{\text{IRQ5}}$ to $\overline{\text{IRQ0}}$ input at low level
	1	Interrupt request generated at falling edge of $\overline{\text{IRQ5}}$ to $\overline{\text{IRQ0}}$ input
1	0	Interrupt request generated at rising edge of $\overline{\text{IRQ5}}$ to $\overline{\text{IRQ0}}$ input
	1	Interrupt request generated at both falling and rising edges of $\overline{\text{IRQ5}}$ to $\overline{\text{IRQ0}}$ input

IER—IRQ Enable Register**H'FE14****Interrupt Controller**

Bit	7	6	5	4	3	2	1	0
	—	—	IRQ5E	IRQ4E	IRQ3E	IRQ2E	IRQ1E	IRQ0E
Initial value	0	0	0	0	0	0	0	0
Read/Write	R/W	R/W	R/W	R/W	R/W	R/W	R/W	R/W

IRQ5 to IRQ0 Enable

0	IRQn interrupts disabled
1	IRQn interrupts enabled

(n = 5 to 0)

ISR—IRQ Status Register**H'FE15****Interrupt Controller**

Bit	7	6	5	4	3	2	1	0
	—	—	IRQ5F	IRQ4F	IRQ3F	IRQ2F	IRQ1F	IRQ0F
Initial value	0	0	0	0	0	0	0	0
Read/Write	R/(W)*	R/(W)*	R/(W)*	R/(W)*	R/(W)*	R/(W)*	R/(W)*	R/(W)*

IRQ5 to IRQ0 Flags

0	<p>[Clearing conditions]</p> <ul style="list-style-type: none"> • Cleared by reading IRQnF when set to 1, then writing 0 in IRQnF • When interrupt exception handling is executed while low-level detection is set (IRQnSCB = IRQnSCA = 0) and $\overline{\text{IRQn}}$ input is high • When IRQn interrupt exception handling is executed while falling, rising, or both-edge detection is set (IRQnSCB = 1 or IRQnSCA = 1) • When the DTC is activated by an IRQn interrupt, and the DISEL bit in MRB of the DTC is cleared to 0
1	<p>[Setting conditions]</p> <ul style="list-style-type: none"> • When $\overline{\text{IRQn}}$ input goes low when low-level detection is set (IRQnSCB = IRQnSCA = 0) • When a falling edge occurs in $\overline{\text{IRQn}}$ input while falling edge detection is set (IRQnSCB = 0, IRQnSCA = 1) • When a rising edge occurs in $\overline{\text{IRQn}}$ input while rising edge detection is set (IRQnSCB = 1, IRQnSCA = 0) • When a falling or rising edge occurs in $\overline{\text{IRQn}}$ input while both-edge detection is set (IRQnSCB = IRQnSCA = 1)

(n = 5 to 0)

Note: * Only 0 can be written, to clear the flag.

DTCERA—DTC Enable Register A	H'FE16	DTC
DTCERB—DTC Enable Register B	H'FE17	DTC
DTCERC—DTC Enable Register C	H'FE18	DTC
DTCERD—DTC Enable Register D	H'FE19	DTC
DTCERE—DTC Enable Register E	H'FE1A	DTC
DTCERF—DTC Enable Register F	H'FE1B	DTC
DTCERG—DTC Enable Register G	H'FE1C	DTC

Note: These registers are not available in the H8S/2635 and H8S/2634.

Bit	7	6	5	4	3	2	1	0
	DTCE7	DTCE6	DTCE5	DTCE4	DTCE3	DTCE2	DTCE1	DTCE0
Initial value	0	0	0	0	0	0	0	0
Read/Write	R/W	R/W	R/W	R/W	R/W	R/W	R/W	R/W

DTC Activation Enable

0	DTC activation by interrupt is disabled [Clearing conditions] <ul style="list-style-type: none"> • When data transfer ends with the DISEL bit set to 1 • When the specified number of transfers end
1	DTC activation by interrupt is enabled [Holding condition] <ul style="list-style-type: none"> • When the DISEL bit is 0 and the specified number of transfers have not ended

DTVECR—DTC Vector Register

H'FE1F

DTC

Bit	7	6	5	4	3	2	1	0
	SWDTE	DTVEC6	DTVEC5	DTVEC4	DTVEC3	DTVEC2	DTVEC1	DTVEC0
Initial value	0	0	0	0	0	0	0	0
Read/Write	R/(W)*1	R/W*2	R/W*2	R/W*2	R/W*2	R/W*2	R/W*2	R/W*2

Set vector number for DTC software activation

DTC Software Activation Enable

0	DTC software activation is disabled [Clearing conditions] <ul style="list-style-type: none"> • When the DISEL bit is 0 and the specified number of transfers have not ended • When 0 is written to DISEL bit after a software-activated data transfer end interrupt (SWDTEND) request has been sent to the CPU.
1	DTC software activation is enabled [Holding conditions] <ul style="list-style-type: none"> • When data transfer ends with the DISEL bit set to 1 • When the specified number of transfers end • During software-activated data transfer

Notes: This register is not available in the H8S/2635 and H8S/2634.

1. Only 1 can be written to the SWDTE bit.
2. Bits DTVEC6 to DTVEC0 can be written to when SWDTE = 0.

PCR—PPG Output Control Register

H'FE26

PPG

Bit	7	6	5	4	3	2	1	0
	G3CMS1	G3CMS0	G2CMS1	G2CMS0	G1CMS1	G1CMS0	G0CMS1	G0CMS0
Initial value	1	1	1	1	1	1	1	1
Read/Write	R/W	R/W	R/W	R/W	R/W	R/W	R/W	R/W

Group 0 Compare Match Select

0	0	Compare match in TPU channel 0
	1	Compare match in TPU channel 1
1	0	Compare match in TPU channel 2
	1	Compare match in TPU channel 3

Group 1 Compare Match Select

0	0	Compare match in TPU channel 0
	1	Compare match in TPU channel 1
1	0	Compare match in TPU channel 2
	1	Compare match in TPU channel 3

Group 2 Compare Match Select

0	0	Compare match in TPU channel 0
	1	Compare match in TPU channel 1
1	0	Compare match in TPU channel 2
	1	Compare match in TPU channel 3

Group 3 Compare Match Select

0	0	Compare match in TPU channel 0
	1	Compare match in TPU channel 1
1	0	Compare match in TPU channel 2
	1	Compare match in TPU channel 3

Note: This register is not available in the H8S/2635 and H8S/2634.

PMR—PPG Output Mode Register

H'FE27

PPG

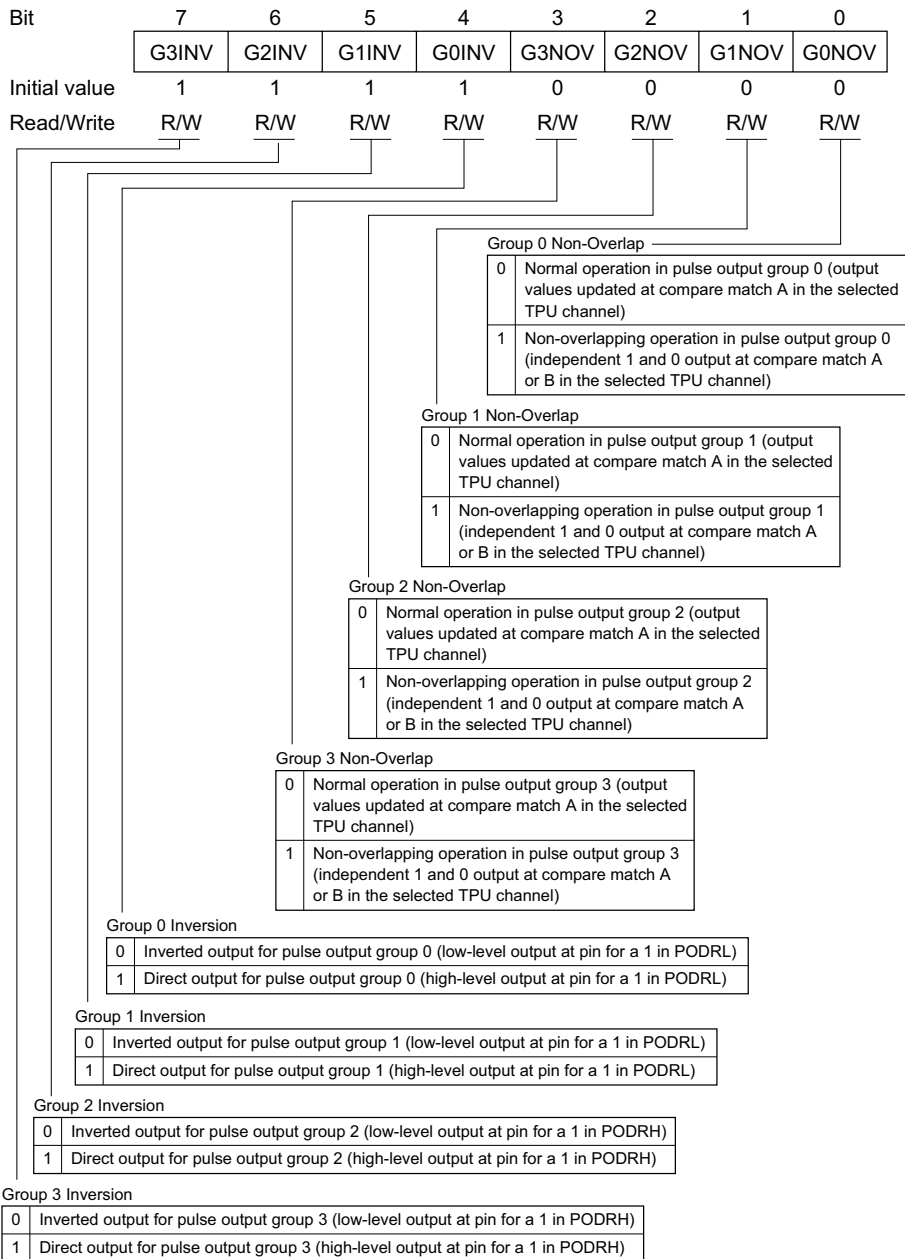

Note: This register is not available in the H8S/2635 and H8S/2634.

NDERH—Next Data Enable Register H**H'FE28****PPG**

Bit	7	6	5	4	3	2	1	0
	NDER15	NDER14	NDER13	NDER12	NDER11	NDER10	NDER9	NDER8
Initial value	0	0	0	0	0	0	0	0
Read/Write	R/W	R/W	R/W	R/W	R/W	R/W	R/W	R/W

Next Data Enable

0	Pulse outputs PO15 to PO8 are disabled (NDR15 to NDR8 are not transferred to POD15 to POD8)
1	Pulse outputs PO15 to PO8 are enabled (NDR15 to NDR8 are transferred to POD15 to POD8)

Note: This register is not available in the H8S/2635 and H8S/2634.

NDERL—Next Data Enable Register L**H'FE29****PPG**

Bit	7	6	5	4	3	2	1	0
	NDER7	NDER6	NDER5	NDER4	NDER3	NDER2	NDER1	NDER0
Initial value	0	0	0	0	0	0	0	0
Read/Write	R/W	R/W	R/W	R/W	R/W	R/W	R/W	R/W

Next Data Enable

0	Pulse outputs PO7 to PO0 are disabled (NDR7 to NDR0 are not transferred to POD7 to POD0)
1	Pulse outputs PO7 to PO0 are enabled (NDR7 to NDR0 are transferred to POD7 to POD0)

Note: This register is not available in the H8S/2635 and H8S/2634.

PODRH—Output Data Register H**H'FE2A****PPG**

Bit	7	6	5	4	3	2	1	0
	POD15	POD14	POD13	POD12	POD11	POD10	POD9	POD8
Initial value	0	0	0	0	0	0	0	0
Read/Write	R/(W)*	R/(W)*	R/(W)*	R/(W)*	R/(W)*	R/(W)*	R/(W)*	R/(W)*

Notes: This register is not available in the H8S/2635 and H8S/2634.

* A bit that has been set for pulse output by NDER is read-only.

PODRL—Output Data Register L**H'FE2B****PPG**

Bit	7	6	5	4	3	2	1	0
	POD7	POD6	POD5	POD4	POD3	POD2	POD1	POD0
Initial value	0	0	0	0	0	0	0	0
Read/Write	R/(W)*	R/(W)*	R/(W)*	R/(W)*	R/(W)*	R/(W)*	R/(W)*	R/(W)*

Notes: This register is not available in the H8S/2635 and H8S/2634.

* A bit that has been set for pulse output by NDER is read-only.

NDRH—Next Data Register H**H'FE2C, H'FE2E****PPG**

Same Trigger for Pulse Output Groups

Address H'FE2C

Bit	7	6	5	4	3	2	1	0
	NDR15	NDR14	NDR13	NDR12	NDR11	NDR10	NDR9	NDR8
Initial value	0	0	0	0	0	0	0	0
Read/Write	R/W	R/W	R/W	R/W	R/W	R/W	R/W	R/W

Address H'FE2E

Bit	7	6	5	4	3	2	1	0
	—	—	—	—	—	—	—	—
Initial value	1	1	1	1	1	1	1	1
Read/Write	—	—	—	—	—	—	—	—

Different Triggers for Pulse Output Groups

Address H'FE2C

Bit	7	6	5	4	3	2	1	0
	NDR15	NDR14	NDR13	NDR12	—	—	—	—
Initial value	0	0	0	0	1	1	1	1
Read/Write	R/W	R/W	R/W	R/W	—	—	—	—

Address H'FE2E

Bit	7	6	5	4	3	2	1	0
	—	—	—	—	NDR11	NDR10	NDR9	NDR8
Initial value	1	1	1	1	0	0	0	0
Read/Write	—	—	—	—	R/W	R/W	R/W	R/W

- Notes: 1. For details, see section 11.2.4, Notes on NDR Access.
 2. This register is not available in the H8S/2635 and H8S/2634.

NDRL—Next Data Register L

H'FE2D, H'FE2F

PPG

Same Trigger for Pulse Output Groups

Address H'FE2D

Bit	7	6	5	4	3	2	1	0
	NDR7	NDR6	NDR5	NDR4	NDR3	NDR2	NDR1	NDR0
Initial value	0	0	0	0	0	0	0	0
Read/Write	R/W	R/W	R/W	R/W	R/W	R/W	R/W	R/W

Address H'FE2F

Bit	7	6	5	4	3	2	1	0
	—	—	—	—	—	—	—	—
Initial value	1	1	1	1	1	1	1	1
Read/Write	—	—	—	—	—	—	—	—

Different Triggers for Pulse Output Groups

Address H'FE2D

Bit	7	6	5	4	3	2	1	0
	NDR7	NDR6	NDR5	NDR4	—	—	—	—
Initial value	0	0	0	0	1	1	1	1
Read/Write	R/W	R/W	R/W	R/W	—	—	—	—

Address H'FE2F

Bit	7	6	5	4	3	2	1	0
	—	—	—	—	NDR3	NDR2	NDR1	NDR0
Initial value	1	1	1	1	0	0	0	0
Read/Write	—	—	—	—	R/W	R/W	R/W	R/W

- Notes: 1. For details, see section 11.2.4, Notes on NDR Access.
 2. This register is not available in the H8S/2635 and H8S/2634.

P1DDR—Port 1 Data Direction Register **H'FE30** **Port**

Bit	7	6	5	4	3	2	1	0
	P17DDR	P16DDR	P15DDR	P14DDR	P13DDR	P12DDR	P11DDR	P10DDR
Initial value	0	0	0	0	0	0	0	0
Read/Write	W	W	W	W	W	W	W	W

Specify input or output for each of the pins in port 1

P3DDR—Port 3 Data Direction Register **H'FE32** **Port**

Bit	7	6	5	4	3	2	1	0
	—	—	P35DDR	P34DDR	P33DDR	P32DDR	P31DDR	P30DDR
Initial value	Undefined	Undefined	0	0	0	0	0	0
Read/Write	—	—	W	W	W	W	W	W

Specify input or output for each of the pins in port 3

PADDR—Port A Data Direction Register **H'FE39** **Port**

Bit	7	6	5	4	3	2	1	0
	—	—	—	—	PA3DDR	PA2DDR	PA1DDR	PA0DDR
Initial value	Undefined	Undefined	Undefined	Undefined	0	0	0	0
Read/Write	—	—	—	—	W	W	W	W

Specify input or output for each of the pins in port A

PBDDR—Port B Data Direction Register **H'FE3A** **Port**

Bit	7	6	5	4	3	2	1	0
	PB7DDR	PB6DDR	PB5DDR	PB4DDR	PB3DDR	PB2DDR	PB1DDR	PB0DDR
Initial value	0	0	0	0	0	0	0	0
Read/Write	W	W	W	W	W	W	W	W

Specify input or output for each of the pins in port B

PCDDR—Port C Data Direction Register**H'FE3B****Port**

Bit	7	6	5	4	3	2	1	0
	PC7DDR	PC6DDR	PC5DDR	PC4DDR	PC3DDR	PC2DDR	PC1DDR	PC0DDR
Initial value	0	0	0	0	0	0	0	0
Read/Write	W	W	W	W	W	W	W	W

Specify input or output for each of the pins in port C

PDDDR—Port D Data Direction Register**H'FE3C****Port**

Bit	7	6	5	4	3	2	1	0
	PD7DDR	PD6DDR	PD5DDR	PD4DDR	PD3DDR	PD2DDR	PD1DDR	PD0DDR
Initial value	0	0	0	0	0	0	0	0
Read/Write	W	W	W	W	W	W	W	W

Specify input or output for each of the pins in port D

PEDDR—Port E Data Direction Register**H'FE3D****Port**

Bit	7	6	5	4	3	2	1	0
	PE7DDR	PE6DDR	PE5DDR	PE4DDR	PE3DDR	PE2DDR	PE1DDR	PE0DDR
Initial value	0	0	0	0	0	0	0	0
Read/Write	W	W	W	W	W	W	W	W

Specify input or output for each of the pins in port E

PFDDR—Port F Data Direction Register**H'FE3E****Port**

Bit	7	6	5	4	3	2	1	0
	PF7DDR	PF6DDR	PF5DDR	PF4DDR	PF3DDR	—	—	PF0DDR

Modes 4, 5, 6

Initial value	1	0	0	0	0	Undefined	Undefined	0
Read/Write	W	W	W	W	W	—	—	W

Mode 7

Initial value	0	0	0	0	0	Undefined	Undefined	0
Read/Write	W	W	W	W	W	—	—	W

Specify input or output for each of the pins in port F

PAPCR—Port A MOS Pull-Up Control Register**H'FE40****Port**

Bit	7	6	5	4	3	2	1	0
	—	—	—	—	PA3PCR	PA2PCR	PA1PCR	PA0PCR
Initial value	Undefined	Undefined	Undefined	Undefined	0	0	0	0
Read/Write	—	—	—	—	R/W	R/W	R/W	R/W

Control the MOS input pull-up function incorporated into port A

PBPCR—Port B MOS Pull-Up Control Register**H'FE41****Port**

Bit	7	6	5	4	3	2	1	0
	PB7PCR	PB6PCR	PB5PCR	PB4PCR	PB3PCR	PB2PCR	PB1PCR	PB0PCR
Initial value	0	0	0	0	0	0	0	0
Read/Write	R/W	R/W	R/W	R/W	R/W	R/W	R/W	R/W

Control the MOS input pull-up function incorporated into port B

PCPCR—Port C MOS Pull-Up Control Register**H'FE42****Port**

Bit	7	6	5	4	3	2	1	0
	PC7PCR	PC6PCR	PC5PCR	PC4PCR	PC3PCR	PC2PCR	PC1PCR	PC0PCR
Initial value	0	0	0	0	0	0	0	0
Read/Write	R/W	R/W	R/W	R/W	R/W	R/W	R/W	R/W

Control the MOS input pull-up function incorporated into port C

PDPCR—Port D MOS Pull-Up Control Register **H'FE43** **Port**

Bit	7	6	5	4	3	2	1	0
	PD7PCR	PD6PCR	PD5PCR	PD4PCR	PD3PCR	PD2PCR	PD1PCR	PD0PCR
Initial value	0	0	0	0	0	0	0	0
Read/Write	R/W	R/W	R/W	R/W	R/W	R/W	R/W	R/W

Control the MOS input pull-up function incorporated into port D

PEPCR—Port E MOS Pull-Up Control Register **H'FE44** **Port**

Bit	7	6	5	4	3	2	1	0
	PE7PCR	PE6PCR	PE5PCR	PE4PCR	PE3PCR	PE2PCR	PE1PCR	PE0PCR
Initial value	0	0	0	0	0	0	0	0
Read/Write	R/W	R/W	R/W	R/W	R/W	R/W	R/W	R/W

Control the MOS input pull-up function incorporated into port E

P3ODR—Port 3 Open Drain Control Register **H'FE46** **Port**

Bit	7	6	5	4	3	2	1	0
	—	—	P35ODR	P34ODR	P33ODR	P32ODR	P31ODR	P30ODR
Initial value	Undefined	Undefined	0	0	0	0	0	0
Read/Write	—	—	R/W	R/W	R/W	R/W	R/W	R/W

PAODR—Port A Open Drain Control Register **H'FE47** **Port**

Bit	7	6	5	4	3	2	1	0
	—	—	—	—	PA3ODR	PA2ODR	PA1ODR	PA0ODR
Initial value	Undefined	Undefined	Undefined	Undefined	0	0	0	0
Read/Write	—	—	—	—	R/W	R/W	R/W	R/W

PBODR—Port B Open Drain Control Register**H'FE48****Port**

Bit	7	6	5	4	3	2	1	0
	PB7ODR	PB6ODR	PB5ODR	PB4ODR	PB3ODR	PB2ODR	PB1ODR	PB0ODR
Initial value	0	0	0	0	0	0	0	0
Read/Write	R/W	R/W	R/W	R/W	R/W	R/W	R/W	R/W

PCODR—Port C Open Drain Control Register**H'FE49****Port**

Bit	7	6	5	4	3	2	1	0
	PC7ODR	PC6ODR	PC5ODR	PC4ODR	PC3ODR	PC2ODR	PC1ODR	PC0ODR
Initial value	0	0	0	0	0	0	0	0
Read/Write	R/W	R/W	R/W	R/W	R/W	R/W	R/W	R/W

TCR3—Timer Control Register 3

H'FE80

TPU3

Bit	7	6	5	4	3	2	1	0
	CCLR2	CCLR1	CCLR0	CKEG1	CKEG0	TPSC2	TPSC1	TPSC0
Initial value	0	0	0	0	0	0	0	0
Read/Write	R/W	R/W	R/W	R/W	R/W	R/W	R/W	R/W

Time Prescaler

0	0	0	Internal clock: counts on $\phi/1$
		1	Internal clock: counts on $\phi/4$
1	0	0	Internal clock: counts on $\phi/16$
		1	Internal clock: counts on $\phi/64$
1	0	0	External clock: counts on TCLKA pin input
		1	Internal clock: counts on $\phi/1024$
	1	0	Internal clock: counts on $\phi/256$
		1	Internal clock: counts on $\phi/4096$

Clock Edge

0	0	Count at rising edge
	1	Count at falling edge
1	—	Count at both edges

Note: Internal clock edge selection is valid when the input clock is $\phi/4$ or slower. This setting is ignored if the input clock is $\phi/1$, or when overflow/underflow of another channel is selected.

Counter Clear

0	0	0	TCNT clearing disabled
		1	TCNT cleared by TGRA compare match/input capture
	1	0	TCNT cleared by TGRB compare match/input capture
		1	TCNT cleared by counter clearing for another channel performing synchronous clearing/synchronous operation*1
1	0	0	TCNT clearing disabled
		1	TCNT cleared by TGRC compare match/input capture*2
	1	0	TCNT cleared by TGRD compare match/input capture*2
		1	TCNT cleared by counter clearing for another channel performing synchronous clearing/synchronous operation*1

- Notes: 1. Synchronous operation setting is performed by setting the SYNC bit in TSYR to 1.
 2. When TGRC or TGRD is used as a buffer register, TCNT is not cleared because the buffer register setting has priority, and compare match/input capture does not occur.

TMDR3—Timer Mode Register 3**H'FE81****TPU3**

Bit	7	6	5	4	3	2	1	0
	—	—	BFB	BFA	MD3	MD2	MD1	MD0
Initial value	1	1	0	0	0	0	0	0
Read/Write	—	—	R/W	R/W	R/W	R/W	R/W	R/W

Mode

0	0	0	0	Normal operation
		1	Reserved	
	1	0	PWM mode 1	
		1	PWM mode 2	
1	0	0	Phase counting mode 1	
		1	Phase counting mode 2	
	1	0	Phase counting mode 3	
		1	Phase counting mode 4	
1	*	*	*	—

*: Don't care

- Notes: 1. MD3 is a reserved bit. In a write, it should always be written with 0.
2. Phase counting mode cannot be set for channel 3. In this case, 0 should always be written to MD2.

Buffer Operation A

0	TGRA operates normally
1	TGRA and TGRC used together for buffer operation

Buffer Operation

0	TGRB operates normally
1	TGRB and TGRD used together for buffer operation

TIOR3H—Timer I/O Control Register 3H

H'FE82

TPU3

Bit	7	6	5	4	3	2	1	0
	IOB3	IOB2	IOB1	IOB0	IOA3	IOA2	IOA1	IOA0
Initial value	0	0	0	0	0	0	0	0
Read/Write	R/W	R/W	R/W	R/W	R/W	R/W	R/W	R/W

TGR3A I/O Control						
0	0	0	0	TGR3A is output compare register	Output disabled	
			1		Initial output is 0 output	0 output at compare match
			0		1 output at compare match	Toggle output at compare match
	1	0	0		Output disabled	
			1		Initial output is 1 output	0 output at compare match
			0		1 output at compare match	Toggle output at compare match
1	0	0	0	TGR3A is input capture register	Capture input source is TIOCA3 pin	Input capture at rising edge
			1		Input capture at falling edge	
			*		Input capture at both edges	
			*		Capture input source is channel 4/count clock	Input capture at TCNT4 count-up/count-down

*: Don't care

TGR3B I/O Control

0	0	0	0	TGR3B is output compare register	Output disabled	
			1		Initial output is 0 output	0 output at compare match
			0		1 output at compare match	Toggle output at compare match
	1	0	0		Output disabled	
			1		Initial output is 1 output	0 output at compare match
			0		1 output at compare match	Toggle output at compare match
1	0	0	0	TGR3B is input capture register	Capture input source is TIOCB3 pin	Input capture at rising edge
			1		Input capture at falling edge	
			*		Input capture at both edges	
			*		Capture input source is channel 4/count clock	Input capture at TCNT4 count-up/count-down ^{*1}

*: Don't care

Note: 1. When bits TPSC2 to TPSC0 in TCR4 are set to B'000 and $\phi/1$ is used as the TCNT4 count clock, this setting is invalid and input capture is not generated.

TIOR3L—Timer I/O Control Register 3L

H'FE83

TPU3

Bit	7	6	5	4	3	2	1	0
	IOD3	IOD2	IOD1	IOD0	IOC3	IOC2	IOC1	IOC0
Initial value	0	0	0	0	0	0	0	0
Read/Write	R/W	R/W	R/W	R/W	R/W	R/W	R/W	R/W

TGR3C I/O Control							
0	0	0	0	TGR3C is output compare register*1	Output disabled		
			1			Initial output is 0 output	0 output at compare match
			0				1 output at compare match
	1	1	Toggle output at compare match				
	1	0	0		0	TGR3C is input capture register*1	Output disabled
					1		
0				1 output at compare match			
1	1	Toggle output at compare match					
1	0	0	0	TGR3C is input capture register*1	Capture input source is TIOCC3 pin		Input capture at rising edge
			1				Input capture at falling edge
			*			Input capture at both edges	
1	*	*	*	Capture input source is channel 4/count clock	Input capture at TCNT4 count-up/count-down		

*: Don't care

Note: 1. When the BFA bit in TMDR3 is set to 1 and TGR3C is used as a buffer register, this setting is invalid and input capture/output compare is not generated.

TGR3D I/O Control

TGR3D I/O Control							
0	0	0	0	TGR3D is output compare register*2	Output disabled		
			1			Initial output is 0 output	0 output at compare match
			0				1 output at compare match
	1	1	Toggle output at compare match				
	1	0	0		0	TGR3D is input capture register*2	Output disabled
					1		
0				1 output at compare match			
1	1	Toggle output at compare match					
1	0	0	0	TGR3D is input capture register*2	Capture input source is TIOCD3 pin		Input capture at rising edge
			1				Input capture at falling edge
			*			Input capture at both edges	
1	*	*	*	Capture input source is channel 4/count clock	Input capture at TCNT4 count-up/count-down*1		

*: Don't care

- Notes: 1. When bits TPSC2 to TPSC0 in TCR4 are set to B'000 and $\phi/1$ is used as the TCNT4 count clock, this setting is invalid and input capture is not generated.
 2. When the BFB bit in TMDR3 is set to 1 and TGR3D is used as a buffer register, this setting is invalid and input capture/output compare is not generated.

Note: When TGRC or TGRD is designated for buffer operation, this setting is invalid and the register operates as a buffer register.

TIER3—Timer Interrupt Enable Register 3

H'FE84

TPU3

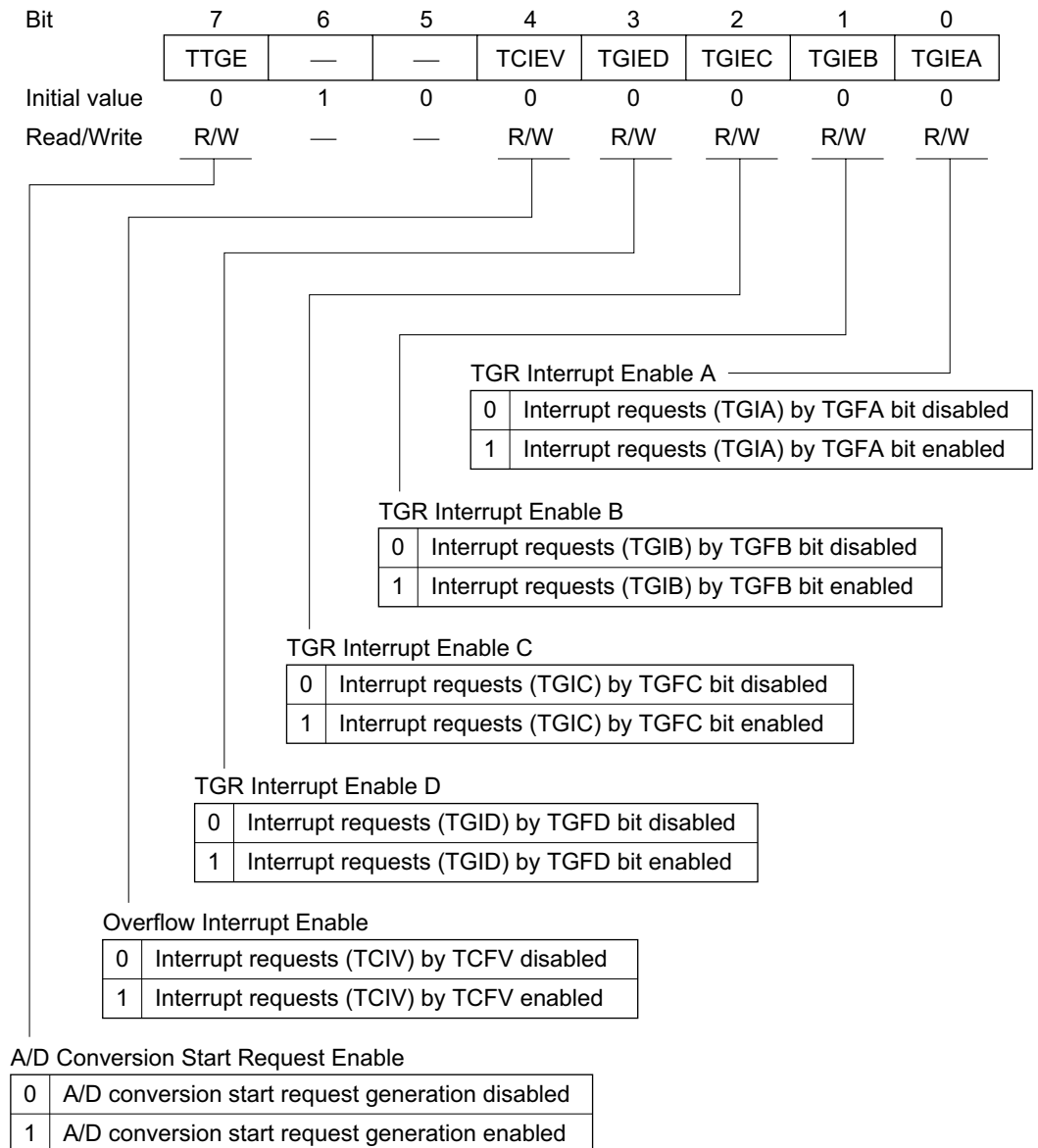

TSR3—Timer Status Register 3

H'FE85

TPU3

Bit	7	6	5	4	3	2	1	0
	—	—	—	TCFV	TGFD	TGFC	TGFB	TGFA
Initial value	1	1	0	0	0	0	0	0
Read/Write	—	—	—	R/(W)*	R/(W)*	R/(W)*	R/(W)*	R/(W)*

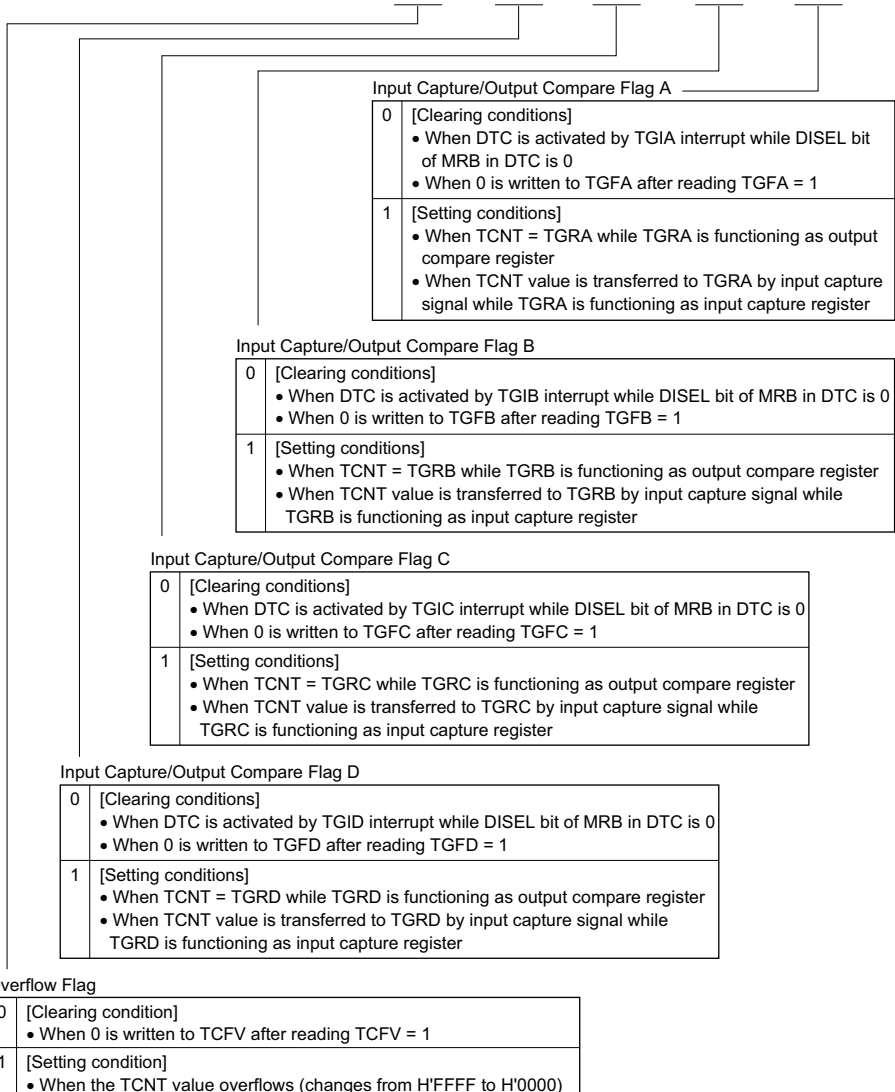

Note: * Can only be written with 0 for flag clearing.

TCNT3—Timer Counter 3**H'FE86****TPU3**

Bit	15	14	13	12	11	10	9	8	7	6	5	4	3	2	1	0
Initial value	0	0	0	0	0	0	0	0	0	0	0	0	0	0	0	0
Read/Write	R/W	R/W	R/W	R/W	R/W	R/W	R/W	R/W	R/W	R/W	R/W	R/W	R/W	R/W	R/W	R/W

|
Up-counter

TGR3A—Timer General Register 3A**H'FE88****TPU3****TGR3B—Timer General Register 3B****H'FE8A****TPU3****TGR3C—Timer General Register 3C****H'FE8C****TPU3****TGR3D—Timer General Register 3D****H'FE8E****TPU3**

Bit	15	14	13	12	11	10	9	8	7	6	5	4	3	2	1	0
Initial value	1	1	1	1	1	1	1	1	1	1	1	1	1	1	1	1
Read/Write	R/W	R/W	R/W	R/W	R/W	R/W	R/W	R/W	R/W	R/W	R/W	R/W	R/W	R/W	R/W	R/W

TCR4—Timer Control Register 4

H'FE90

TPU4

Bit	7	6	5	4	3	2	1	0
	—	CCLR1	CCLR0	CKEG1	CKEG0	TPSC2	TPSC1	TPSC0
Initial value	0	0	0	0	0	0	0	0
Read/Write	—	R/W	R/W	R/W	R/W	R/W	R/W	R/W

Time Prescaler

0	0	0	Internal clock: counts on $\phi/1$
		1	Internal clock: counts on $\phi/4$
	1	0	Internal clock: counts on $\phi/16$
		1	Internal clock: counts on $\phi/64$
1	0	0	External clock: counts on TCLKA pin input
		1	External clock: counts on TCLKC pin input
	1	0	Internal clock: counts on $\phi/1024$
		1	Counts on TCNT5 overflow/underflow

Note: This setting is ignored when channel 4 is in phase counting mode.

Clock Edge

0	0	Count at rising edge
	1	Count at falling edge
1	—	Count at both edges

Note: This setting is ignored when channel 4 is in phase counting mode.

Internal clock edge selection is valid when the input clock is $\phi/4$ or slower. This setting is ignored if the input clock is $\phi/1$, or when overflow/underflow of another channel is selected.

Counter Clear

0	0	TCNT clearing disabled
	1	TCNT cleared by TGRA compare match/input capture
1	0	TCNT cleared by TGRB compare match/input capture
	1	TCNT cleared by counter clearing for another channel performing synchronous clearing/synchronous operation*

Note: * Synchronous operation setting is performed by setting the SYNC bit in TSYR to 1.

TMDR4—Timer Mode Register 4

H'FE91

TPU4

Bit	7	6	5	4	3	2	1	0
	—	—	—	—	MD3	MD2	MD1	MD0
Initial value	1	1	1	1	0	0	0	0
Read/Write	—	—	—	—	R/W	R/W	R/W	R/W

Mode

0	0	0	0	Normal operation
			1	Reserved
		1	0	PWM mode 1
			1	PWM mode 2
	1	0	0	Phase counting mode 1
			1	Phase counting mode 2
		1	0	Phase counting mode 3
			1	Phase counting mode 4
1	*	*	*	—

*: Don't care

Note: MD3 is a reserved bit. In a write, it should always be written with 0.

TIOR4—Timer I/O Control Register 4

H'FE92

TPU4

Bit	7	6	5	4	3	2	1	0
	IOB3	IOB2	IOB1	IOB0	IOA3	IOA2	IOA1	IOA0
Initial value	0	0	0	0	0	0	0	0
Read/Write	R/W	R/W	R/W	R/W	R/W	R/W	R/W	R/W

TGR4A I/O Control

0	0	0	0	TGR4A is output compare register	Output disabled	
			1		Initial output is 0 output	0 output at compare match
			0			1 output at compare match
	1	Initial output is 1 output	0 output at compare match			
	0		1 output at compare match			
	1		Toggle output at compare match			
1	0	0	0	TGR4A is input capture register	Capture input source is TIOCA4 pin	
			1		Input capture at rising edge	
			0			Input capture at falling edge
	1	Input capture at both edges				
	0		Input capture at generation of TGR3A compare match/input capture			
	1	* * *				

*: Don't care

TGR4B I/O Control

0	0	0	0	TGR4B is output compare register	Output disabled	
			1		Initial output is 0 output	0 output at compare match
			0			1 output at compare match
	1	Initial output is 1 output	0 output at compare match			
	0		1 output at compare match			
	1		Toggle output at compare match			
1	0	0	0	TGR4B is input capture register	Capture input source is TIOCB4 pin	
			1		Input capture at rising edge	
			0			Input capture at falling edge
	1	Input capture at both edges				
	0		Input capture at generation of TGR3C compare match/input capture			
	1	* * *				

*: Don't care

TIER4—Timer Interrupt Enable Register 4

H'FE94

TPU4

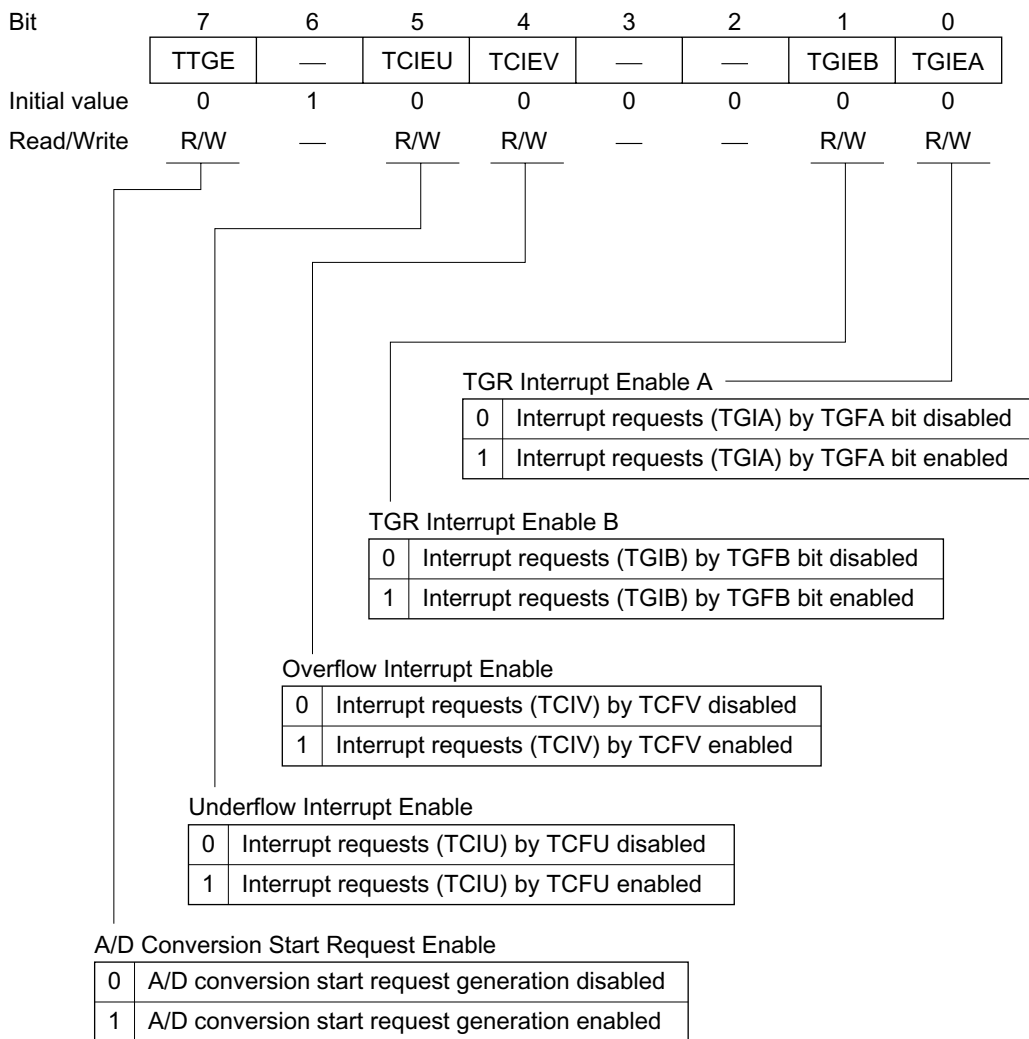

TSR4—Timer Status Register 4

H'FE95

TPU4

Bit	7	6	5	4	3	2	1	0
	TCFD	—	TCFU	TCFV	—	—	TGFB	TGFA
Initial value	1	1	0	0	0	0	0	0
Read/Write	R	—	R/(W)*	R/(W)*	—	—	R/(W)*	R/(W)*

Input Capture/Output Compare Flag A

0	[Clearing conditions]
	<ul style="list-style-type: none"> When DTC is activated by TGIA interrupt while DISEL bit of MRB in DTC is 0 When 0 is written to TGFA after reading TGFA = 1
1	[Setting conditions]
	<ul style="list-style-type: none"> When TCNT = TGRA while TGRA is functioning as output compare register When TCNT value is transferred to TGRA by input capture signal while TGRA is functioning as input capture register

Input Capture/Output Compare Flag B

0	[Clearing conditions]
	<ul style="list-style-type: none"> When DTC is activated by TGIB interrupt while DISEL bit of MRB in DTC is 0 When 0 is written to TGFB after reading TGFB = 1
1	[Setting conditions]
	<ul style="list-style-type: none"> When TCNT = TGRB while TGRB is functioning as output compare register When TCNT value is transferred to TGRB by input capture signal while TGRB is functioning as input capture register

Overflow Flag

0	[Clearing condition]
	<ul style="list-style-type: none"> When 0 is written to TCFV after reading TCFV = 1
1	[Setting condition]
	<ul style="list-style-type: none"> When the TCNT value overflows (changes from H'FFFF to H'0000)

Underflow Flag

0	[Clearing condition]
	<ul style="list-style-type: none"> When 0 is written to TCFU after reading TCFU = 1
1	[Setting condition]
	<ul style="list-style-type: none"> When the TCNT value underflows (changes from H'0000 to H'FFFF)

Count Direction Flag

0	TCNT counts down
1	TCNT counts up

Note: * Can only be written with 0 for flag clearing.

TCNT4—Timer Counter 4**H'FE96****TPU4**

Bit	15	14	13	12	11	10	9	8	7	6	5	4	3	2	1	0
Initial value	0	0	0	0	0	0	0	0	0	0	0	0	0	0	0	0
Read/Write	R/W	R/W	R/W	R/W	R/W	R/W	R/W	R/W	R/W	R/W	R/W	R/W	R/W	R/W	R/W	R/W

|
Up/down-counter*

Note: * These counters can be used as up/down-counters only in phase counting mode or when counting overflow/underflow on another channel. In other cases they function as up-counters.

TGR4A—Timer General Register 4A**H'FE98****TPU4****TGR4B—Timer General Register 4B****H'FE9A****TPU4**

Bit	15	14	13	12	11	10	9	8	7	6	5	4	3	2	1	0
Initial value	1	1	1	1	1	1	1	1	1	1	1	1	1	1	1	1
Read/Write	R/W	R/W	R/W	R/W	R/W	R/W	R/W	R/W	R/W	R/W	R/W	R/W	R/W	R/W	R/W	R/W

TCR5—Timer Control Register 5

H'FEA0

TPU5

Bit	7	6	5	4	3	2	1	0
	—	CCLR1	CCLR0	CKEG1	CKEG0	TPSC2	TPSC1	TPSC0
Initial value	0	0	0	0	0	0	0	0
Read/Write	—	R/W	R/W	R/W	R/W	R/W	R/W	R/W

Time Prescaler

0	0	0	Internal clock: counts on $\phi/1$
		1	Internal clock: counts on $\phi/4$
	1	0	Internal clock: counts on $\phi/16$
		1	Internal clock: counts on $\phi/64$
1	0	0	External clock: counts on TCLKA pin input
		1	External clock: counts on TCLKC pin input
	1	0	Internal clock: counts on $\phi/256$
		1	External clock: counts on TCLKD pin input

Note: This setting is ignored when channel 5 is in phase counting mode.

Clock Edge

0	0	Count at rising edge
	1	Count at falling edge
1		Count at both edges

Note: This setting is ignored when channel 5 is in phase counting mode.

Internal clock edge selection is valid when the input clock is $\phi/4$ or slower. This setting is ignored if the input clock is $\phi/1$, or when overflow/underflow of another channel is selected.

Counter Clear

0	0	TCNT clearing disabled
	1	TCNT cleared by TGRA compare match/input capture
1	0	TCNT cleared by TGRB compare match/input capture
	1	TCNT cleared by counter clearing for another channel performing synchronous clearing/synchronous operation*

Note: * Synchronous operation setting is performed by setting the SYNC bit in TSYR to 1.

TMDR5—Timer Mode Register 5

H'FEA1

TPU5

Bit	7	6	5	4	3	2	1	0
	—	—	—	—	MD3	MD2	MD1	MD0
Initial value	1	1	0	0	0	0	0	0
Read/Write	—	—	—	—	R/W	R/W	R/W	R/W

Mode

0	0	0	0	Normal operation
			1	Reserved
	1	0	0	PWM mode 1
			1	PWM mode 2
1	0	0	0	Phase counting mode 1
			1	Phase counting mode 2
	1	0	0	Phase counting mode 3
			1	Phase counting mode 4
1	*	*	*	—

*: Don't care

Note: MD3 is a reserved bit. In a write, it should always be written with 0.

TIOR5—Timer I/O Control Register 5

H'FEA2

TPU5

Bit	7	6	5	4	3	2	1	0
	IOB3	IOB2	IOB1	IOB0	IOA3	IOA2	IOA1	IOA0
Initial value	0	0	0	0	0	0	0	0
Read/Write	R/W	R/W	R/W	R/W	R/W	R/W	R/W	R/W

TGR5A I/O Control

0	0	0	0	TGR5A is output compare register	Output disabled			
			1	Initial output is 0 output	0 output at compare match			
			0	1 output at compare match				
		1	0	0	Output disabled			
			1	Initial output is 1 output	0 output at compare match			
			0	1 output at compare match	Toggle output at compare match			
	1	*	0	0	TGR5A is input capture register	Capture input source is TIOCA5 pin	Input capture at rising edge	
				1	Input capture at falling edge			
				*	Input capture at both edges			
		1	*	0	1			
					1			
					*			

*: Don't care

TGR5B I/O Control

0	0	0	0	TGR5B is output compare register	Output disabled			
			1	Initial output is 0 output	0 output at compare match			
			0	1 output at compare match	Toggle output at compare match			
		1	0	0	Output disabled			
			1	Initial output is 1 output	0 output at compare match			
			0	1 output at compare match	Toggle output at compare match			
	1	*	0	0	TGR5B is input capture register	Capture input source is TIOCB5 pin	Input capture at rising edge	
				1	Input capture at falling edge			
				*	Input capture at both edges			
		1	*	0	1			
					1			
					*			

*: Don't care

TIER5—Timer Interrupt Enable Register 5

H'FEA4

TPU5

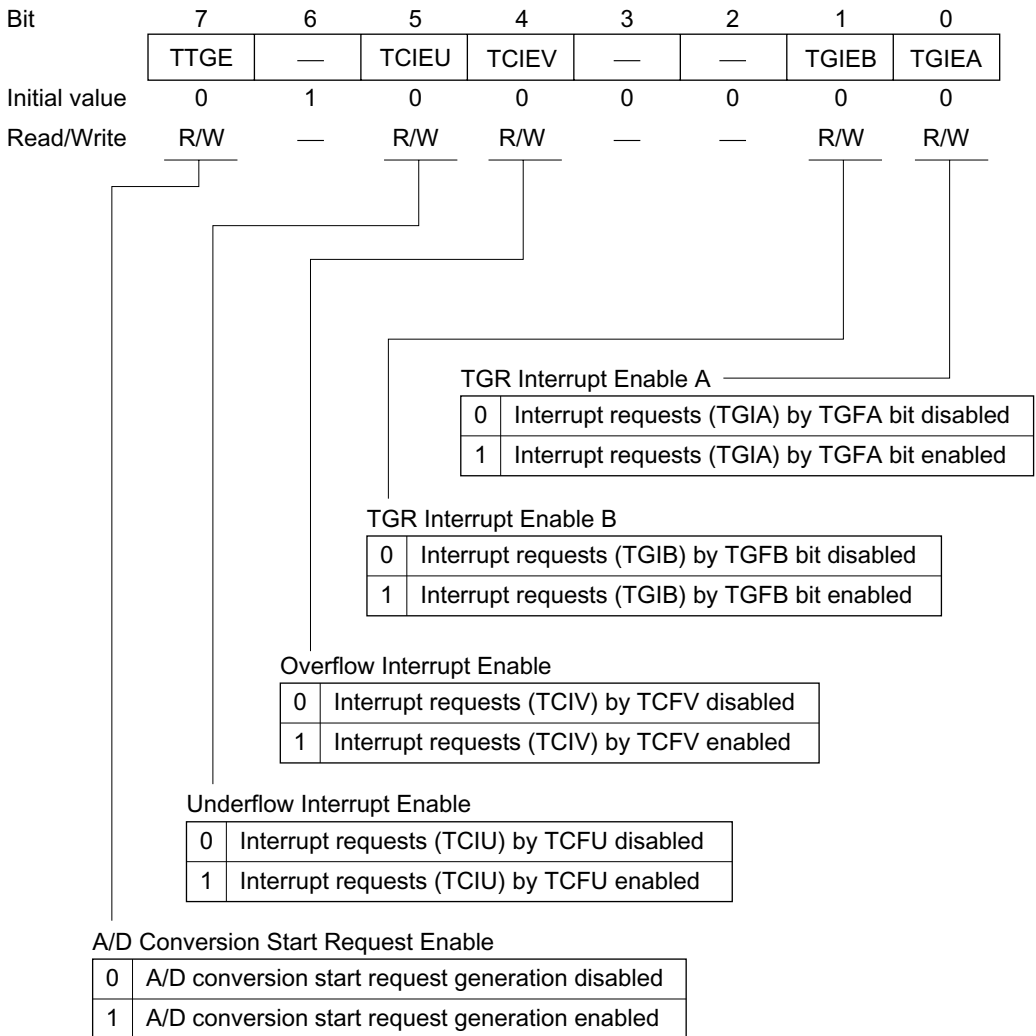

TSR5—Timer Status Register 5

H'FEA5

TPU5

Bit	7	6	5	4	3	2	1	0
	TCFD	—	TCFU	TCFV	—	—	TGFB	TGFA
Initial value	1	1	0	0	0	0	0	0
Read/Write	R	—	R/(W)*	R/(W)*	—	—	R/(W)*	R/(W)*

Input Capture/Output Compare Flag A

0	[Clearing conditions]
	<ul style="list-style-type: none"> When DTC is activated by TGIA interrupt while DISEL bit of MRB in DTC is 0 When 0 is written to TGFA after reading TGFA = 1
1	[Setting conditions]
	<ul style="list-style-type: none"> When TCNT = TGRA while TGRA is functioning as output compare register When TCNT value is transferred to TGRA by input capture signal while TGRA is functioning as input capture register

Input Capture/Output Compare Flag B

0	[Clearing conditions]
	<ul style="list-style-type: none"> When DTC is activated by TGIB interrupt while DISEL bit of MRB in DTC is 0 When 0 is written to TGFB after reading TGFB = 1
1	[Setting conditions]
	<ul style="list-style-type: none"> When TCNT = TGRB while TGRB is functioning as output compare register When TCNT value is transferred to TGRB by input capture signal while TGRB is functioning as input capture register

Overflow Flag

0	[Clearing condition]
	<ul style="list-style-type: none"> When 0 is written to TCFV after reading TCFV = 1
1	[Setting condition]
	<ul style="list-style-type: none"> When the TCNT value overflows (changes from H'FFFF to H'0000)

Underflow Flag

0	[Clearing condition]
	<ul style="list-style-type: none"> When 0 is written to TCFU after reading TCFU = 1
1	[Setting condition]
	<ul style="list-style-type: none"> When the TCNT value underflows (changes from H'0000 to H'FFFF)

Count Direction Flag

0	TCNT counts down
1	TCNT counts up

Note: * Can only be written with 0 for flag clearing.

TCNT5—Timer Counter 5**H'FEA6****TPU5**

Bit	15	14	13	12	11	10	9	8	7	6	5	4	3	2	1	0
Initial value	0	0	0	0	0	0	0	0	0	0	0	0	0	0	0	0
Read/Write	R/W	R/W	R/W	R/W	R/W	R/W	R/W	R/W	R/W	R/W	R/W	R/W	R/W	R/W	R/W	R/W

Up/down-counter*

Note: * These counters can be used as up/down-counters only in phase counting mode or when counting overflow/underflow on another channel. In other cases they function as up-counters.

TGR5A—Timer General Register 5A**H'FEA8****TPU5****TGR5B—Timer General Register 5B****H'FEAA****TPU5**

Bit	15	14	13	12	11	10	9	8	7	6	5	4	3	2	1	0
Initial value	1	1	1	1	1	1	1	1	1	1	1	1	1	1	1	1
Read/Write	R/W	R/W	R/W	R/W	R/W	R/W	R/W	R/W	R/W	R/W	R/W	R/W	R/W	R/W	R/W	R/W

TSTR—Timer Start Register**H'FEB0****TPU**

Bit	7	6	5	4	3	2	1	0
	—	—	CST5	CST4	CST3	CST2	CST1	CST0
Initial value	0	0	0	0	0	0	0	0
Read/Write	—	—	R/W	R/W	R/W	R/W	R/W	R/W

Counter Start

0	TCNTn count operation is stopped
1	TCNTn performs count operation

(n = 5 to 0)

Note: If 0 is written to the CST bit during operation with the TIOC pin designated for output, the counter stops but the TIOC pin output compare output level is retained. If TIOR is written to when the CST bit is cleared to 0, the pin output level will be changed to the set initial output value.

TSYR—Timer Synchro Register**H'FEB1****TPU**

Bit	7	6	5	4	3	2	1	0
	—	—	SYNC5	SYNC4	SYNC3	SYNC2	SYNC1	SYNC0
Initial value	0	0	0	0	0	0	0	0
Read/Write	—	—	R/W	R/W	R/W	R/W	R/W	R/W

Timer Synchro

0	TCNTn operates independently (TCNT presetting/clearing is unrelated to other channels)
1	TCNTn performs synchronous operation TCNT synchronous presetting/synchronous clearing is possible

(n = 5 to 0)

- Notes:
1. To set synchronous operation, the SYNC bits for at least two channels must be set to 1.
 2. To set synchronous clearing, in addition to the SYNC bit, the TCNT clearing source must also be set by means of bits CCLR2 to CCLR0 in TCR.

IPRA—Interrupt Priority Register A	H'FEC0	INT
IPRB—Interrupt Priority Register B	H'FEC1	INT
IPRC—Interrupt Priority Register C	H'FEC2	INT
IPRD—Interrupt Priority Register D	H'FEC3	INT
IPRE—Interrupt Priority Register E	H'FEC4	INT
IPRF—Interrupt Priority Register F	H'FEC5	INT
IPRG—Interrupt Priority Register G	H'FEC6	INT
IPRH—Interrupt Priority Register H	H'FEC7	INT
IPRJ—Interrupt Priority Register J	H'FEC9	INT
IPRK—Interrupt Priority Register K	H'FECA	INT
IPRL—Interrupt Priority Register L	H'FECEB	INT
IPRM—Interrupt Priority Register M	H'FECEC	INT

Bit	7	6	5	4	3	2	1	0
	—	IPR6	IPR5	IPR4	—	IPR2	IPR1	IPR0
Initial value	0	1	1	1	0	1	1	1
Read/Write	—	R/W	R/W	R/W	—	R/W	R/W	R/W

Correspondence between Interrupt Sources and IPR Settings

Register	Bits	
	6 to 4	2 to 0
IPRA	IRQ0	IRQ1
IPRB	IRQ2	IRQ4
	IRQ3	IRQ5
IPRC	—*1	DTC*3
IPRD	Watchdog timer 0	—*1
IPRE	PC break*3	A/D converter, watchdog timer 1
IPRF	TPU channel 0	TPU channel 1
IPRG	TPU channel 2	TPU channel 3
IPRH	TPU channel 4	TPU channel 5
IPRJ	—*1	SCI channel 0
IPRK	SCI channel 1	SCI channel 2
IPRL	—*1	IIC (Option)*2
IPRM	PWM channel 1, 2, HCAN channel 1*3	HCAN channel 0

- Notes: 1. Reserved. Read-only bits, always read as 1.
2. I²C bus interface is available as an option in the H8S/2638, H8S/2639, H8S/2630. The IIC bit becomes reserved bit when this optional feature is not used.
3. The DTC, PC break, and HCAN1 are not implemented in the H8S/2635 and H8S/2634.

ABWCR—Bus Width Control Register**H'FED0****Bus Controller**

Bit	7	6	5	4	3	2	1	0
	ABW7	ABW6	ABW5	ABW4	ABW3	ABW2	ABW1	ABW0

Modes 5 to 7

Initial value	1	1	1	1	1	1	1	1
Read/Write	R/W	R/W	R/W	R/W	R/W	R/W	R/W	R/W

Mode 4

Initial value	0	0	0	0	0	0	0	0
Read/Write	R/W	R/W	R/W	R/W	R/W	R/W	R/W	R/W

Area 7 to 0 Bus Width Control

0	Area n is designated for 16-bit access
1	Area n is designated for 8-bit access

(n = 7 to 0)

ASTCR—Access State Control Register**H'FED1****Bus Controller**

Bit	7	6	5	4	3	2	1	0
	AST7	AST6	AST5	AST4	AST3	AST2	AST1	AST0
Initial value	1	1	1	1	1	1	1	1
Read/Write	R/W	R/W	R/W	R/W	R/W	R/W	R/W	R/W

Area 7 to 0 Access State Control

0	Area n is designated for 2-state access Wait state insertion in area n external space is disabled
1	Area n is designated for 3-state access Wait state insertion in area n external space is enabled

(n = 7 to 0)

WCRH—Wait Control Register H

H'FED2

Bus Controller

Bit	7	6	5	4	3	2	1	0
	W71	W70	W61	W60	W51	W50	W41	W40
Initial value	1	1	1	1	1	1	1	1
Read/Write	R/W	R/W	R/W	R/W	R/W	R/W	R/W	R/W

Area 4 Wait Control 1 and 0

0	0	Program wait not inserted when external space area 4 is accessed
	1	1 program wait state inserted when external space area 4 is accessed
1	0	2 program wait states inserted when external space area 4 is accessed
	1	3 program wait states inserted when external space area 4 is accessed

Area 5 Wait Control 1 and 0

0	0	Program wait not inserted when external space area 5 is accessed
	1	1 program wait state inserted when external space area 5 is accessed
1	0	2 program wait states inserted when external space area 5 is accessed
	1	3 program wait states inserted when external space area 5 is accessed

Area 6 Wait Control 1 and 0

0	0	Program wait not inserted when external space area 6 is accessed
	1	1 program wait state inserted when external space area 6 is accessed
1	0	2 program wait states inserted when external space area 6 is accessed
	1	3 program wait states inserted when external space area 6 is accessed

Area 7 Wait Control 1 and 0

0	0	Program wait not inserted when external space area 7 is accessed
	1	1 program wait state inserted when external space area 7 is accessed
1	0	2 program wait states inserted when external space area 7 is accessed
	1	3 program wait states inserted when external space area 7 is accessed

WCRL—Wait Control Register L

H'FED3

Bus Controller

Bit	7	6	5	4	3	2	1	0
	W31	W30	W21	W20	W11	W10	W01	W00
Initial value	1	1	1	1	1	1	1	1
Read/Write	R/W	R/W	R/W	R/W	R/W	R/W	R/W	R/W

Area 0 Wait Control 1 and 0

0	0	Program wait not inserted when external space area 0 is accessed
	1	1 program wait state inserted when external space area 0 is accessed
1	0	2 program wait states inserted when external space area 0 is accessed
	1	3 program wait states inserted when external space area 0 is accessed

Area 1 Wait Control 1 and 0

0	0	Program wait not inserted when external space area 1 is accessed
	1	1 program wait state inserted when external space area 1 is accessed
1	0	2 program wait states inserted when external space area 1 is accessed
	1	3 program wait states inserted when external space area 1 is accessed

Area 2 Wait Control 1 and 0

0	0	Program wait not inserted when external space area 2 is accessed
	1	1 program wait state inserted when external space area 2 is accessed
1	0	2 program wait states inserted when external space area 2 is accessed
	1	3 program wait states inserted when external space area 2 is accessed

Area 3 Wait Control 1 and 0

0	0	Program wait not inserted when external space area 3 is accessed
	1	1 program wait state inserted when external space area 3 is accessed
1	0	2 program wait states inserted when external space area 3 is accessed
	1	3 program wait states inserted when external space area 3 is accessed

BCRH—Bus Control Register H

H'FED4

Bus Controller

Bit	7	6	5	4	3	2	1	0
	ICIS1	ICIS0	BRSTRM	BRSTS1	BRSTS0	—	—	—
Initial value	1	1	0	1	0	0	0	0
Read/Write	R/W	R/W	R/W	R/W	R/W	R/W	R/W	R/W

Burst Cycle Select 0

0	Max. 4 words in burst access
1	Max. 8 words in burst access

Burst Cycle Select 1

0	Burst cycle comprises 1 state
1	Burst cycle comprises 2 states

Burst ROM Enable

0	Area 0 is basic bus interface
1	Area 0 is burst ROM interface

Idle Cycle Insert 0

0	Idle cycle not inserted in case of successive external read and external write cycles
1	Idle cycle inserted in case of successive external read and external write cycles

Idle Cycle Insert 1

0	Idle cycle not inserted in case of successive external read cycles in different areas
1	Idle cycle inserted in case of successive external read cycles in different areas

BCRL—Bus Control Register L**H'FED5****Bus Controller**

Bit	7	6	5	4	3	2	1	0
	—	—	—	—	—	—	WDBE	—
Initial value	0	0	0	0	1	0	0	0
Read/Write	R/W	R/W	—	R/W	R/W	R/W	R/W	R/W

Write Data Buffer Enable

0	Write data buffer function not used
1	Write data buffer function used

RAMER—RAM Emulation Register

H'FEDB

Flash Memory

Bit	7	6	5	4	3	2	1	0
	—	—	—	—	RAMS	RAM2	RAM1	RAM0
Initial value	0	0	0	0	0	0	0	0
Read/Write	R	R	R/W	R/W	R/W	R/W	R/W	R/W

Flash Memory Area Selection

• H8S/2636

Addresses	Block Name	RAMS	RAM2	RAM1	RAM0
H'FFE000–H'FFE3FF	RAM area 1 kB	0	*	*	*
H'000000–H'0003FF	EB0 (1 kB)	1	0	0	
H'000400–H'0007FF	EB1 (1 kB)			1	
H'000800–H'000BFF	EB2 (1 kB)		1	0	
H'000C00–H'000FFF	EB3 (1 kB)			1	

*: Don't care

• H8S/2638, H8S/2639, H8S/2630

Addresses	Block Name	RAMS	RAM2	RAM1	RAM0	
H'FFD000–H'FFDFFF	RAM area 4 kB	0	*	*	*	
H'000000–H'000FFF	EB0 (4 kB)	1	0	0	0	
H'001000–H'001FFF	EB1 (4 kB)			1	1	
H'002000–H'002FFF	EB2 (4 kB)			1	0	
H'003000–H'003FFF	EB3 (4 kB)		1	0	0	1
H'004000–H'004FFF	EB4 (4 kB)				0	0
H'005000–H'005FFF	EB5 (4 kB)			1	1	
H'006000–H'006FFF	EB6 (4 kB)			1	0	
H'007000–H'007FFF	EB7 (4 kB)	1	1			

*: Don't care

• H8S/2635

Addresses	Block Name	RAMS	RAM2	RAM1	RAM0	
H'FFD800–H'FFE7FF	RAM area 4 kB	0	*	*	*	
H'000000–H'000FFF	EB0 (4 kB)	1	0	0	0	
H'001000–H'001FFF	EB1 (4 kB)			1	1	
H'002000–H'002FFF	EB2 (4 kB)			1	0	
H'003000–H'003FFF	EB3 (4 kB)		1	0	0	1
H'004000–H'004FFF	EB4 (4 kB)				0	0
H'005000–H'005FFF	EB5 (4 kB)			1	1	
H'006000–H'006FFF	EB6 (4 kB)			1	0	
H'007000–H'007FFF	EB7 (4 kB)	1	1			

*: Don't care

RAM Select

0	Emulation not selected Program/erase-protection of all flash memory blocks is disabled
1	Emulation selected Program/erase-protection of all flash memory blocks is enabled

P1DR—Port 1 Data Register**H'FF00****Port**

Bit	7	6	5	4	3	2	1	0
	P17DR	P16DR	P15DR	P14DR	P13DR	P12DR	P11DR	P10DR
Initial value	0	0	0	0	0	0	0	0
Read/Write	R/W	R/W	R/W	R/W	R/W	R/W	R/W	R/W

P3DR—Port 3 Data Register**H'FF02****Port**

Bit	7	6	5	4	3	2	1	0
	—	—	P35DR	P34DR	P33DR	P32DR	P31DR	P30DR
Initial value	Undefined	Undefined	0	0	0	0	0	0
Read/Write	—	—	R/W	R/W	R/W	R/W	R/W	R/W

PADR—Port A Data Register**H'FF09****Port**

Bit	7	6	5	4	3	2	1	0
	—	—	—	—	PA3DR	PA2DR	PA1DR	PA0DR
Initial value	Undefined	Undefined	Undefined	Undefined	0	0	0	0
Read/Write	—	—	—	—	R/W	R/W	R/W	R/W

PBDR—Port B Data Register**H'FF0A****Port**

Bit	7	6	5	4	3	2	1	0
	PB7DR	PB6DR	PB5DR	PB4DR	PB3DR	PB2DR	PB1DR	PB0DR
Initial value	0	0	0	0	0	0	0	0
Read/Write	R/W	R/W	R/W	R/W	R/W	R/W	R/W	R/W

PCDR—Port C Data Register**H'FF0B****Port**

Bit	7	6	5	4	3	2	1	0
	PC7DR	PC6DR	PC5DR	PC4DR	PC3DR	PC2DR	PC1DR	PC0DR
Initial value	0	0	0	0	0	0	0	0
Read/Write	R/W	R/W	R/W	R/W	R/W	R/W	R/W	R/W

PDDR—Port D Data Register**H'FF0C****Port**

Bit	7	6	5	4	3	2	1	0
	PD7DR	PD6DR	PD5DR	PD4DR	PD3DR	PD2DR	PD1DR	PD0DR
Initial value	0	0	0	0	0	0	0	0
Read/Write	R/W	R/W	R/W	R/W	R/W	R/W	R/W	R/W

PEDR—Port E Data Register**H'FF0D****Port**

Bit	7	6	5	4	3	2	1	0
	PE7DR	PE6DR	PE5DR	PE4DR	PE3DR	PE2DR	PE1DR	PE0DR
Initial value	0	0	0	0	0	0	0	0
Read/Write	R/W	R/W	R/W	R/W	R/W	R/W	R/W	R/W

PFDR—Port F Data Register**H'FF0E****Port**

Bit	7	6	5	4	3	2	1	0
	PF7DR	PF6DR	PF5DR	PF4DR	PF3DR	—	—	PF0DR
Initial value	0	0	0	0	0	Undefined	Undefined	0
Read/Write	R/W	R/W	R/W	R/W	R/W	—	—	R/W

TCR0—Timer Control Register 0

H'FF10

TPU0

Bit	7	6	5	4	3	2	1	0
	CCLR2	CCLR1	CCLR0	CKEG1	CKEG0	TPSC2	TPSC1	TPSC0
Initial value	0	0	0	0	0	0	0	0
Read/Write	R/W	R/W	R/W	R/W	R/W	R/W	R/W	R/W

Time Prescaler

0	0	0	Internal clock: counts on $\phi/1$
	1	1	Internal clock: counts on $\phi/4$
1	0	0	Internal clock: counts on $\phi/16$
	1	1	Internal clock: counts on $\phi/64$
1	0	0	External clock: counts on TCLKA pin input
	1	1	External clock: counts on TCLKB pin input
1	0	0	External clock: counts on TCLKC pin input
	1	1	External clock: counts on TCLKD pin input

Clock Edge

0	0	Count at rising edge
	1	Count at falling edge
1	—	Count at both edges

Note: Internal clock edge selection is valid when the input clock is $\phi/4$ or slower. This setting is ignored if the input clock is $\phi/1$, or when overflow/underflow of another channel is selected.

Counter Clear

0	0	0	TCNT clearing disabled
		1	TCNT cleared by TGRA compare match/input capture
	1	0	TCNT cleared by TGRB compare match/input capture
		1	TCNT cleared by counter clearing for another channel performing synchronous clearing/synchronous operation*1
1	0	0	TCNT clearing disabled
		1	TCNT cleared by TGRC compare match/input capture*2
	1	0	TCNT cleared by TGRD compare match/input capture*2
		1	TCNT cleared by counter clearing for another channel performing synchronous clearing/synchronous operation*1

- Notes: 1. Synchronous operation setting is performed by setting the SYNC bit in TSYR to 1.
 2. When TGRC or TGRD is used as a buffer register, TCNT is not cleared because the buffer register setting has priority, and compare match/input capture does not occur.

TMDR0—Timer Mode Register 0

H'FF11

TPU0

Bit	7	6	5	4	3	2	1	0
	—	—	BFB	BFA	MD3	MD2	MD1	MD0
Initial value	1	1	0	0	0	0	0	0
Read/Write	—	—	R/W	R/W	R/W	R/W	R/W	R/W

Mode

0	0	0	0	Normal operation
			1	Reserved
	1	0	0	PWM mode 1
			1	PWM mode 2
1	0	0	0	Phase counting mode 1
			1	Phase counting mode 2
	1	0	0	Phase counting mode 3
			1	Phase counting mode 4
1	*	*	*	—

*: Don't care

- Notes: 1. MD3 is a reserved bit. In a write, it should always be written with 0.
2. Phase counting mode cannot be set for channel 0. In this case, 0 should always be written to MD2.

Buffer Operation A

0	TGRA operates normally
1	TGRA and TGRC used together for buffer operation

Buffer Operation

0	TGRB operates normally
1	TGRB and TGRD used together for buffer operation

TIOR0H—Timer I/O Control Register 0H

H'FF12

TPU0

Bit	7	6	5	4	3	2	1	0
	IOB3	IOB2	IOB1	IOB0	IOA3	IOA2	IOA1	IOA0
Initial value	0	0	0	0	0	0	0	0
Read/Write	R/W	R/W	R/W	R/W	R/W	R/W	R/W	R/W

TGR0A I/O Control

0	0	0	0	TGR0A is output compare register	Output disabled		
			1		Initial output is 0 output	0 output at compare match	
			0			1 output at compare match	
	1	1	0		TGR0A is input capture register	Output disabled	
	0		Initial output is 1 output			0 output at compare match	
	1					1 output at compare match	
1	0	0	0	TGR0A is input capture register	Capture input source is TIOCA0 pin	Input capture at rising edge	
			1			Input capture at falling edge	
	*	Input capture at both edges					
	1	*	*		Capture input source is channel 1/count clock	Input capture at TCNT1 count-up/count-down	

*: Don't care

TGR0B I/O Control

0	0	0	0	TGR0B is output compare register	Output disabled		
			1		Initial output is 0 output	0 output at compare match	
			0			1 output at compare match	
	1	1	0		TGR0B is input capture register	Output disabled	
	0		Initial output is 1 output			0 output at compare match	
	1					1 output at compare match	
1	0	0	0	TGR0B is input capture register	Capture input source is TIOCB0 pin	Input capture at rising edge	
			1			Input capture at falling edge	
	*	Input capture at both edges					
	1	*	*		Capture input source is channel 1/count clock	Input capture at TCNT1 count-up/count-down*1	

*: Don't care

Note: 1. When bits TPSC2 to TPSC0 in TCR1 are set to B'000 and $\phi/1$ is used as the TCNT1 count clock, this setting is invalid and input capture is not generated.

TIOR0L—Timer I/O Control Register 0L

H'FF13

TPU0

Bit	7	6	5	4	3	2	1	0
	IOD3	IOD2	IOD1	IOD0	IOC3	IOC2	IOC1	IOC0
Initial value	0	0	0	0	0	0	0	0
Read/Write	R/W	R/W	R/W	R/W	R/W	R/W	R/W	R/W

TGR0C I/O Control

0	0	0	0	TGR0C is output compare register*1	Output disabled			
					1	0	Initial output is 0 output	0 output at compare match
							1 output at compare match	Toggle output at compare match
	1	0	0		Output disabled			
					1	0	Initial output is 1 output	0 output at compare match
							1 output at compare match	Toggle output at compare match
1	0	0	0	TGR0C is input capture register*1	Capture input source is TIOCC0 pin			
					1	*	Input capture at rising edge	Input capture at falling edge
							Input capture at both edges	
1	*	*	0		Capture input source is channel 1/count clock			
					Input capture at TCNT1 count-up/count-down			

*: Don't care

Note: 1. When the BFA bit in TMDR0 is set to 1 and TGR0C is used as a buffer register, this setting is invalid and input capture/output compare is not generated.

TGR0D I/O Control

0	0	0	0	TGR0D is output compare register*2	Output disabled			
					1	0	Initial output is 0 output	0 output at compare match
							1 output at compare match	Toggle output at compare match
	1	0	0		Output disabled			
					1	0	Initial output is 1 output	0 output at compare match
							1 output at compare match	Toggle output at compare match
1	0	0	0	TGR0D is input capture register*2	Capture input source is TIOCD0 pin			
					1	*	Input capture at rising edge	Input capture at falling edge
							Input capture at both edges	
1	*	*	0		Capture input source is channel 1/count clock			
					Input capture at TCNT1 count-up/count-down*1			

*: Don't care

- Notes: 1. When bits TPSC2 to TPSC0 in TCR1 are set to B'000 and $\phi/1$ is used as the TCNT1 count clock, this setting is invalid and input capture is not generated.
 2. When the BFB bit in TMDR0 is set to 1 and TGR0D is used as a buffer register, this setting is invalid and input capture/output compare is not generated.

Note: When TGRC or TGRD is designated for buffer operation, this setting is invalid and the register operates as a buffer register.

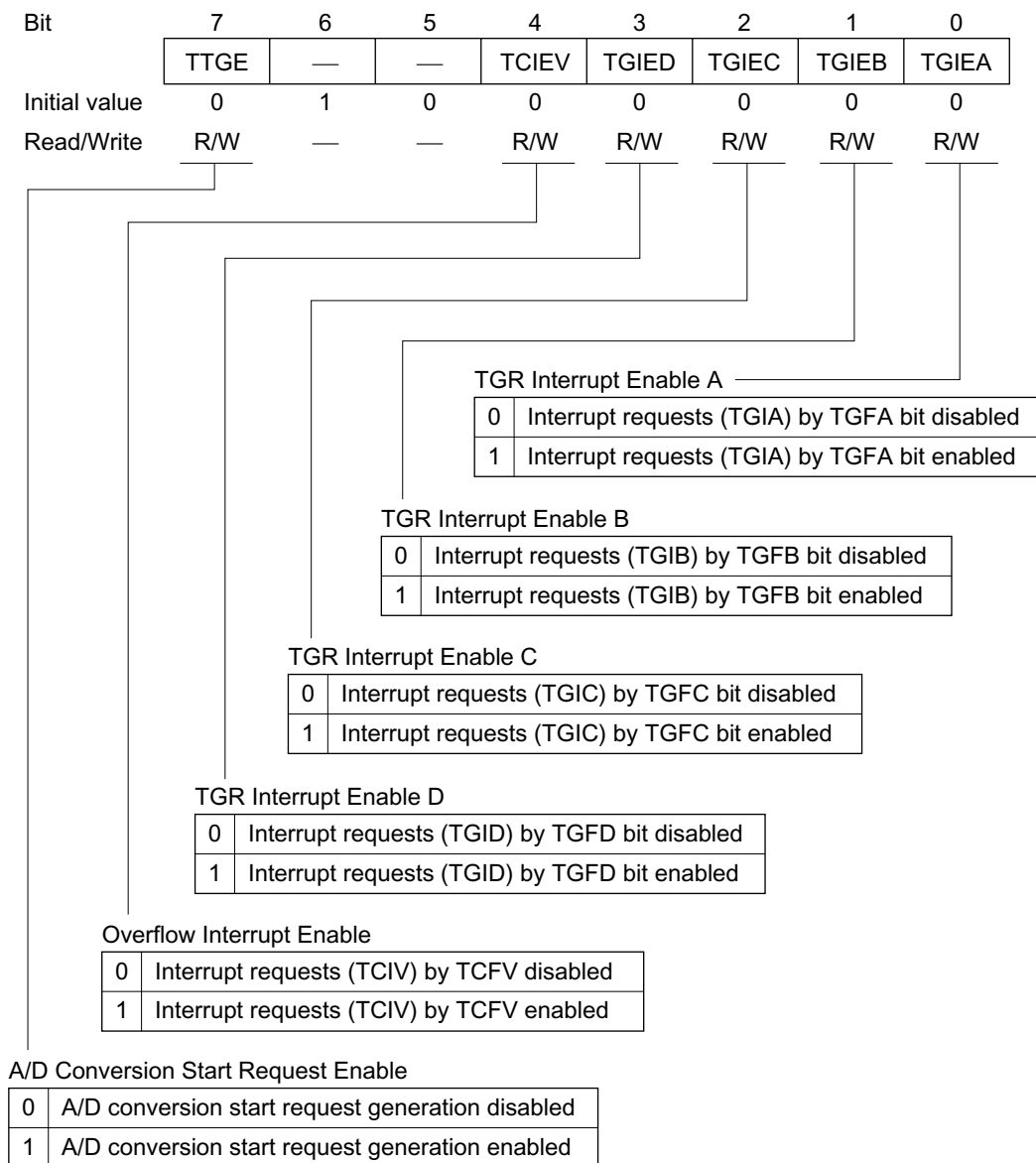
TIER0—Timer Interrupt Enable Register 0**H'FF14****TPU0**

TSR0—Timer Status Register 0

H'FF15

TPU0

Bit	7	6	5	4	3	2	1	0
	—	—	—	TCFV	TGFD	TGFC	TGFB	TGFA
Initial value	1	1	0	0	0	0	0	0
Read/Write	—	—	—	R/(W)*	R/(W)*	R/(W)*	R/(W)*	R/(W)*

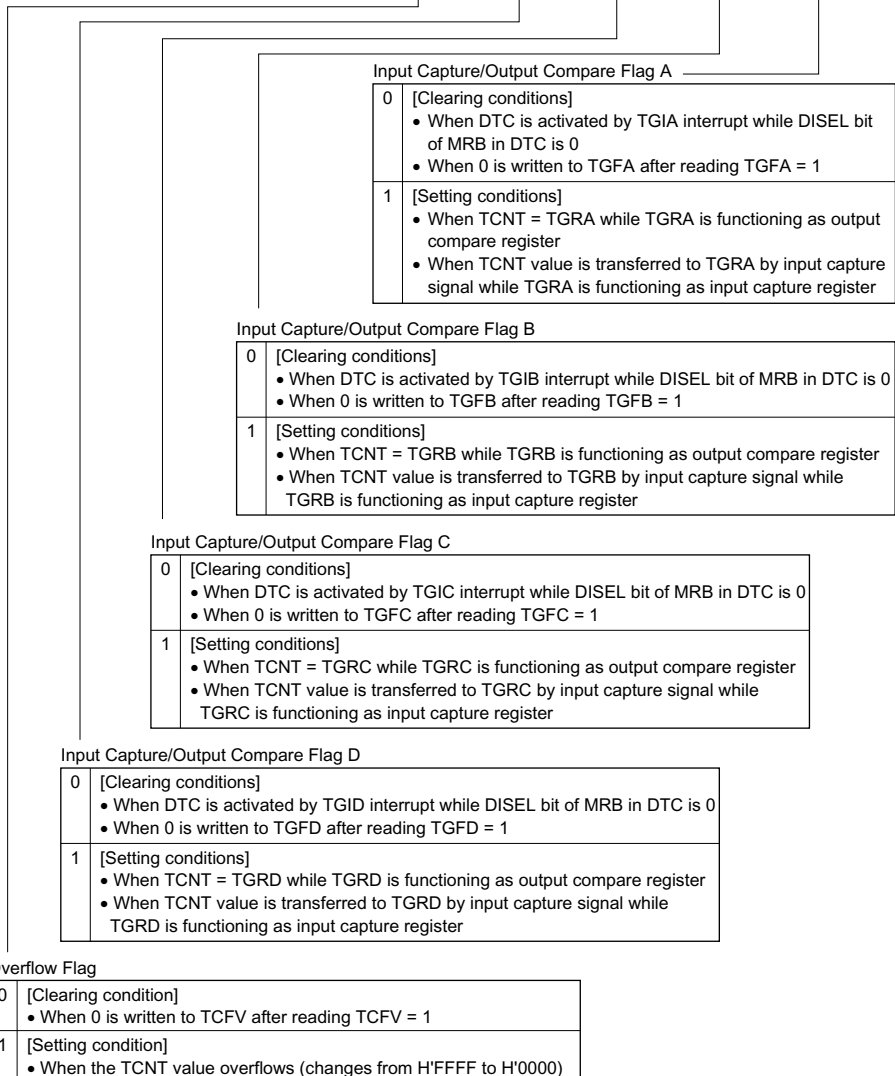

Note: * Can only be written with 0 for flag clearing.

TCNT0—Timer Counter 0**H'FF16****TPU0**

Bit	15	14	13	12	11	10	9	8	7	6	5	4	3	2	1	0
Initial value	0	0	0	0	0	0	0	0	0	0	0	0	0	0	0	0
Read/Write	R/W	R/W	R/W	R/W	R/W	R/W	R/W	R/W	R/W	R/W	R/W	R/W	R/W	R/W	R/W	R/W

Up-counter

TGR0A—Timer General Register 0A**H'FF18****TPU0****TGR0B—Timer General Register 0B****H'FF1A****TPU0****TGR0C—Timer General Register 0C****H'FF1C****TPU0****TGR0D—Timer General Register 0D****H'FF1E****TPU0**

Bit	15	14	13	12	11	10	9	8	7	6	5	4	3	2	1	0
Initial value	1	1	1	1	1	1	1	1	1	1	1	1	1	1	1	1
Read/Write	R/W	R/W	R/W	R/W	R/W	R/W	R/W	R/W	R/W	R/W	R/W	R/W	R/W	R/W	R/W	R/W

TCR1—Timer Control Register 1

H'FF20

TPU1

Bit	7	6	5	4	3	2	1	0
	—	CCLR1	CCLR0	CKEG1	CKEG0	TPSC2	TPSC1	TPSC0
Initial value	0	0	0	0	0	0	0	0
Read/Write	—	R/W	R/W	R/W	R/W	R/W	R/W	R/W

Time Prescaler

0	0	0	Internal clock: counts on $\phi/1$
		1	Internal clock: counts on $\phi/4$
	1	0	Internal clock: counts on $\phi/16$
		1	Internal clock: counts on $\phi/64$
1	0	0	External clock: counts on TCLKA pin input
		1	External clock: counts on TCLKB pin input
	1	0	Internal clock: counts on $\phi/256$
		1	Counts on TCNT2 overflow/underflow

Note: This setting is ignored when channel 1 is in phase counting mode.

Clock Edge

0	0	Count at rising edge
	1	Count at falling edge
1	—	Count at both edges

Note: This setting is ignored when channel 1 is in phase counting mode.

Internal clock edge selection is valid when the input clock is $\phi/4$ or slower. This setting is ignored if the input clock is $\phi/1$, or when overflow/underflow of another channel is selected.

Counter Clear

0	0	TCNT clearing disabled
	1	TCNT cleared by TGRA compare match/input capture
1	0	TCNT cleared by TGRB compare match/input capture
	1	TCNT cleared by counter clearing for another channel performing synchronous clearing/synchronous operation*

Note: * Synchronous operation setting is performed by setting the SYNC bit in TSYR to 1.

TMDR1—Timer Mode Register 1**H'FF21****TPU1**

Bit	7	6	5	4	3	2	1	0
	—	—	—	—	MD3	MD2	MD1	MD0
Initial value	1	1	0	0	0	0	0	0
Read/Write	—	—	—	—	R/W	R/W	R/W	R/W

Mode

0	0	0	0	Normal operation
		1	Reserved	
	1	0	PWM mode 1	
		1	PWM mode 2	
1	0	0	Phase counting mode 1	
		1	Phase counting mode 2	
	1	0	Phase counting mode 3	
		1	Phase counting mode 4	
1	*	*	*	—

*: Don't care

Note: MD3 is a reserved bit. In a write, it should always be written with 0.

TIOR1—Timer I/O Control Register 1

H'FF22

TPU1

Bit	7	6	5	4	3	2	1	0
	IOB3	IOB2	IOB1	IOB0	IOA3	IOA2	IOA1	IOA0
Initial value	0	0	0	0	0	0	0	0
Read/Write	R/W	R/W	R/W	R/W	R/W	R/W	R/W	R/W

TGR1A I/O Control

0	0	0	0	TGR1A is output compare register	Output disabled		
			1		Initial output is 0 output	0 output at compare match	
			0			1 output at compare match	
		1	Toggle output at compare match				
		1	0		0	TGR1A is input capture register	Output disabled
					1		Initial output is 1 output
	0			1 output at compare match			
	1	Toggle output at compare match					
	1	0	0	TGR1A is input capture register	Capture input source is TIOCA1 pin		Input capture at rising edge
			1		*		Input capture at falling edge
			1		*	Input capture at both edges	
	1	*	*	TGR1A is input capture register	Capture input source is TGR0A compare match/ input capture	Input capture at generation of channel 0/TGR0A compare match/ input capture	

*: Don't care

TGR1B I/O Control

0	0	0	0	TGR1B is output compare register	Output disabled		
			1		Initial output is 0 output	0 output at compare match	
			0			1 output at compare match	
		1	Toggle output at compare match				
		1	0		0	TGR1B is input capture register	Output disabled
					1		Initial output is 1 output
	0			1 output at compare match			
	1	Toggle output at compare match					
	1	0	0	TGR1B is input capture register	Capture input source is TIOCB1 pin		Input capture at rising edge
			1		*		Input capture at falling edge
			1		*	Input capture at both edges	
	1	*	*	TGR1B is input capture register	Capture input source is TGR0C compare match/ input capture	Input capture at generation of TGR0C compare match/input capture	

*: Don't care

TIER1—Timer Interrupt Enable Register 1**H'FF24****TPU1**

Bit	7	6	5	4	3	2	1	0
	TTGE	—	TCIEU	TCIEV	—	—	TGIEB	TGIEA
Initial value	0	1	0	0	0	0	0	0
Read/Write	R/W	—	R/W	R/W	—	—	R/W	R/W

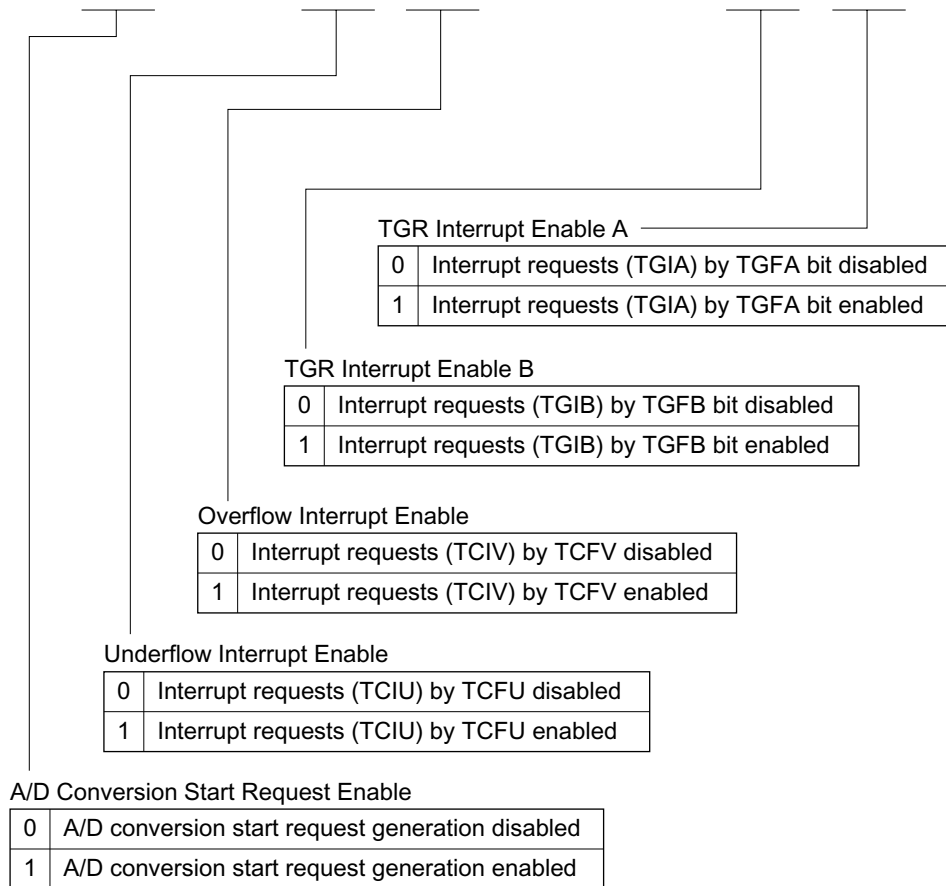

TSR1—Timer Status Register 1

H'FF25

TPU1

Bit	7	6	5	4	3	2	1	0
	TCFD	—	TCFU	TCFV	—	—	TGFB	TGFA
Initial value	1	1	0	0	0	0	0	0
Read/Write	R	—	R/(W)*	R/(W)*	—	—	R/(W)*	R/(W)*

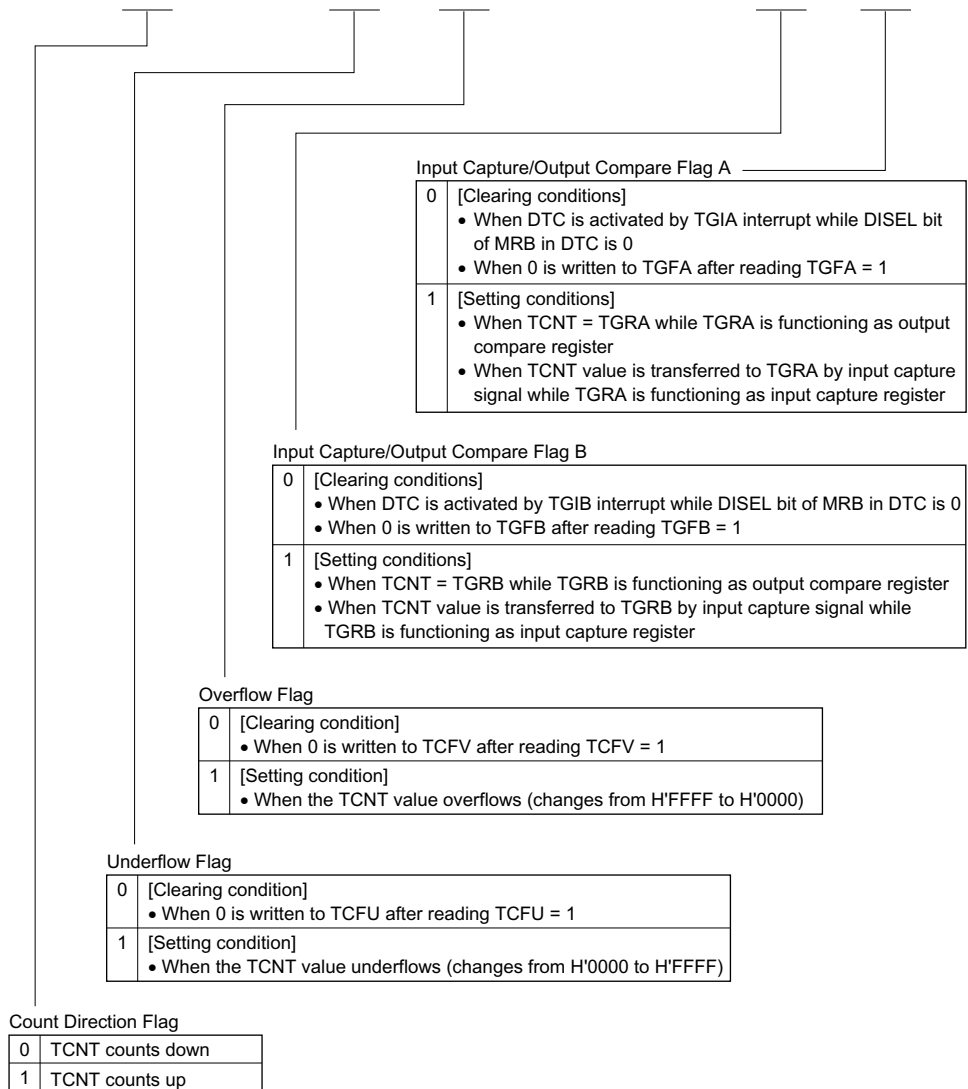

Note: * Can only be written with 0 for flag clearing.

TCNT1—Timer Counter 1**H'FF26****TPU1**

Bit	15	14	13	12	11	10	9	8	7	6	5	4	3	2	1	0
	<input type="checkbox"/>	<input type="checkbox"/>	<input type="checkbox"/>	<input type="checkbox"/>	<input type="checkbox"/>	<input type="checkbox"/>	<input type="checkbox"/>	<input type="checkbox"/>	<input type="checkbox"/>	<input type="checkbox"/>	<input type="checkbox"/>	<input type="checkbox"/>	<input type="checkbox"/>	<input type="checkbox"/>	<input type="checkbox"/>	<input type="checkbox"/>
Initial value	0	0	0	0	0	0	0	0	0	0	0	0	0	0	0	0
Read/Write	R/W	R/W	R/W	R/W	R/W	R/W	R/W	R/W	R/W	R/W	R/W	R/W	R/W	R/W	R/W	R/W

|
Up/down-counter*

Note: * These counters can be used as up/down-counters only in phase counting mode or when counting overflow/underflow on another channel. In other cases they function as up-counters.

TGR1A—Timer General Register 1A**H'FF28****TPU1****TGR1B—Timer General Register 1B****H'FF2A****TPU1**

Bit	15	14	13	12	11	10	9	8	7	6	5	4	3	2	1	0
	<input type="checkbox"/>	<input type="checkbox"/>	<input type="checkbox"/>	<input type="checkbox"/>	<input type="checkbox"/>	<input type="checkbox"/>	<input type="checkbox"/>	<input type="checkbox"/>	<input type="checkbox"/>	<input type="checkbox"/>	<input type="checkbox"/>	<input type="checkbox"/>	<input type="checkbox"/>	<input type="checkbox"/>	<input type="checkbox"/>	<input type="checkbox"/>
Initial value	1	1	1	1	1	1	1	1	1	1	1	1	1	1	1	1
Read/Write	R/W	R/W	R/W	R/W	R/W	R/W	R/W	R/W	R/W	R/W	R/W	R/W	R/W	R/W	R/W	R/W

TCR2—Timer Control Register 2

H'FF30

TPU2

Bit	7	6	5	4	3	2	1	0
	—	CCLR1	CCLR0	CKEG1	CKEG0	TPSC2	TPSC1	TPSC0
Initial value	0	0	0	0	0	0	0	0
Read/Write	—	R/W	R/W	R/W	R/W	R/W	R/W	R/W

Time Prescaler

0	0	0	Internal clock: counts on $\phi/1$
		1	Internal clock: counts on $\phi/4$
	1	0	Internal clock: counts on $\phi/16$
		1	Internal clock: counts on $\phi/64$
1	0	0	External clock: counts on TCLKA pin input
		1	External clock: counts on TCLKB pin input
	1	0	External clock: counts on TCLKC pin input
		1	Internal clock: counts on $\phi/1024$

Note: This setting is ignored when channel 2 is in phase counting mode.

Clock Edge

0	0	Count at rising edge
	1	Count at falling edge
1	—	Count at both edges

Note: This setting is ignored when channel 2 is in phase counting mode.

Internal clock edge selection is valid when the input clock is $\phi/4$ or slower. This setting is ignored if the input clock is $\phi/1$, or when overflow/underflow of another channel is selected.

Counter Clear

0	0	TCNT clearing disabled
	1	TCNT cleared by TGRA compare match/input capture
1	0	TCNT cleared by TGRB compare match/input capture
	1	TCNT cleared by counter clearing for another channel performing synchronous clearing/synchronous operation*

Note: * Synchronous operation setting is performed by setting the SYNC bit in TSYR to 1.

TMDR2—Timer Mode Register 2**H'FF31****TPU2**

Bit	7	6	5	4	3	2	1	0
	—	—	—	—	MD3	MD2	MD1	MD0
Initial value	1	1	0	0	0	0	0	0
Read/Write	—	—	—	—	R/W	R/W	R/W	R/W

Mode

0	0	0	0	Normal operation
			1	Reserved
		1	0	PWM mode 1
			1	PWM mode 2
	1	0	0	Phase counting mode 1
			1	Phase counting mode 2
		1	0	Phase counting mode 3
			1	Phase counting mode 4
1	*	*	*	—

*: Don't care

Note: MD3 is a reserved bit. In a write, it should always be written with 0.

TIOR2—Timer I/O Control Register 2

H'FF32

TPU2

Bit	7	6	5	4	3	2	1	0
	IOB3	IOB2	IOB1	IOB0	IOA3	IOA2	IOA1	IOA0
Initial value	0	0	0	0	0	0	0	0
Read/Write	R/W	R/W	R/W	R/W	R/W	R/W	R/W	R/W

TGR2A I/O Control

0	0	0	0	TGR2A is output compare register	Output disabled				
			1		Initial output is 0 output	0 output at compare match			
			0			1 output at compare match			
		1	Toggle output at compare match						
		1	0		0	Output disabled			
					1	Initial output is 1 output	0 output at compare match		
	0				1 output at compare match				
	1	Toggle output at compare match							
	1	*			0	0	TGR2A is input capture register	Capture input	
						1		source is TIOCA2 pin	Input capture at rising edge
			1			Input capture at falling edge			
					*		Input capture at both edges		

*: Don't care

TGR2B I/O Control

0	0	0	0	TGR2B is output compare register	Output disabled				
			1		Initial output is 0 output	0 output at compare match			
			0			1 output at compare match			
		1	Toggle output at compare match						
		1	0		0	0	Output disabled		
						1	Initial output is 1 output	0 output at compare match	
	0					1 output at compare match			
	1	Toggle output at compare match							
	1	*			0	0	TGR2B is input capture register	Capture input	
						1		source is TIOCB2 pin	Input capture at rising edge
			1			Input capture at falling edge			
					*		Input capture at both edges		

*: Don't care

TIER2—Timer Interrupt Enable Register 2

H'FF34

TPU2

Bit	7	6	5	4	3	2	1	0
	TTGE	—	TCIEU	TCIEV	—	—	TGIEB	TGIEA
Initial value	0	1	0	0	0	0	0	0
Read/Write	R/W	—	R/W	R/W	—	—	R/W	R/W

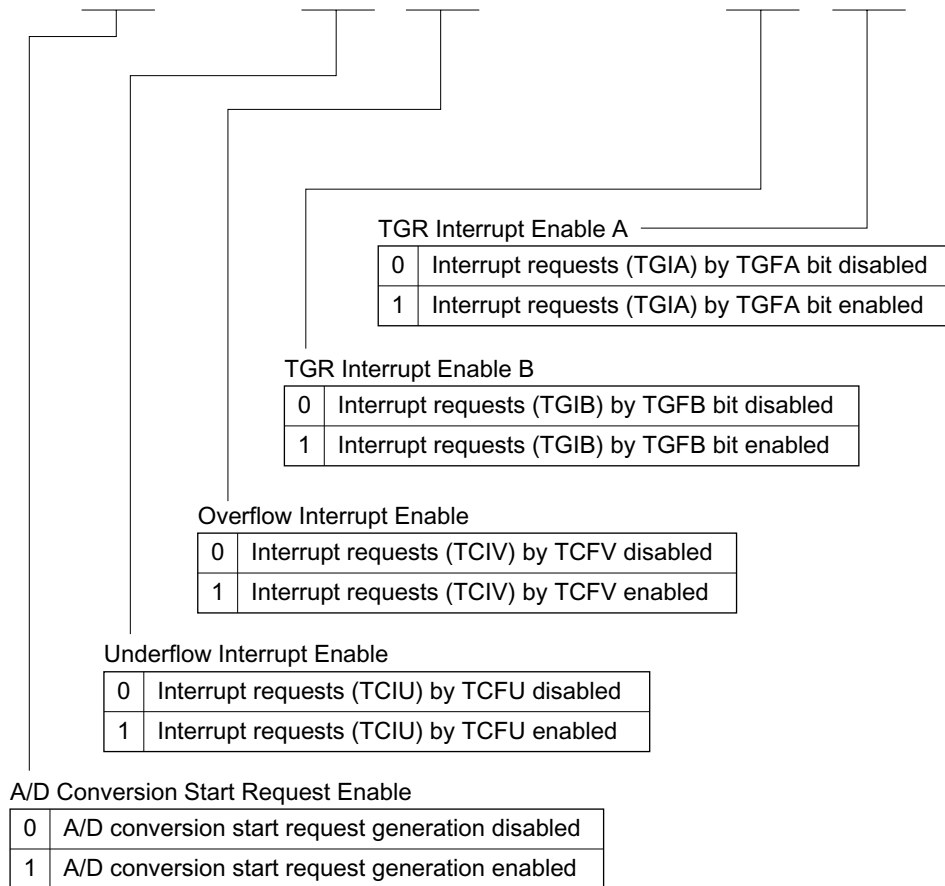

TSR2—Timer Status Register 2

H'FF35

TPU2

Bit	7	6	5	4	3	2	1	0
	TCFD	—	TCFU	TCFV	—	—	TGFB	TGFA
Initial value	1	1	0	0	0	0	0	0
Read/Write	R	—	R/(W)*	R/(W)*	—	—	R/(W)*	R/(W)*

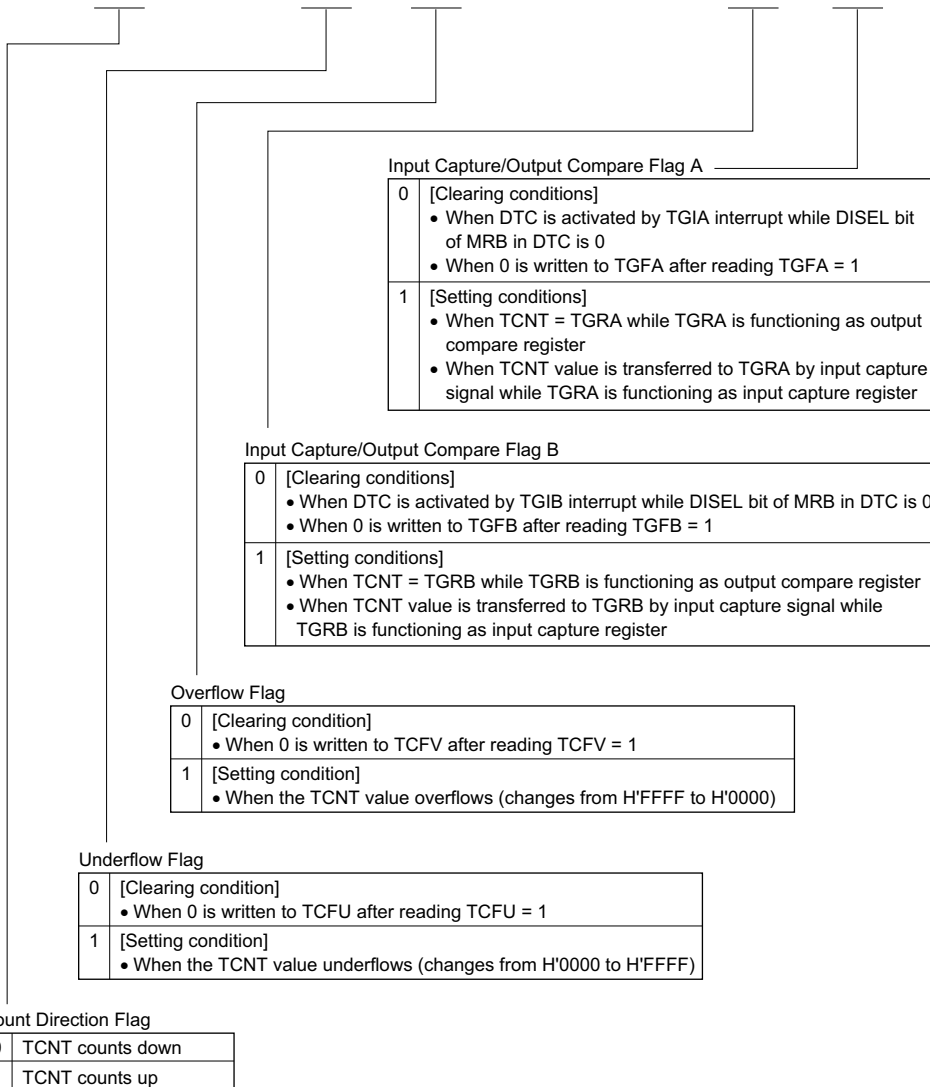

Note: * Can only be written with 0 for flag clearing.

TCNT2—Timer Counter 2**H'FF36****TPU2**

Bit	15	14	13	12	11	10	9	8	7	6	5	4	3	2	1	0
	<input type="checkbox"/>	<input type="checkbox"/>	<input type="checkbox"/>	<input type="checkbox"/>	<input type="checkbox"/>	<input type="checkbox"/>	<input type="checkbox"/>	<input type="checkbox"/>	<input type="checkbox"/>	<input type="checkbox"/>	<input type="checkbox"/>	<input type="checkbox"/>	<input type="checkbox"/>	<input type="checkbox"/>	<input type="checkbox"/>	<input type="checkbox"/>
Initial value	0	0	0	0	0	0	0	0	0	0	0	0	0	0	0	0
Read/Write	R/W	R/W	R/W	R/W	R/W	R/W	R/W	R/W	R/W	R/W	R/W	R/W	R/W	R/W	R/W	R/W

|
Up/down-counter*

Note: * These counters can be used as up/down-counters only in phase counting mode or when counting overflow/underflow on another channel. In other cases they function as up-counters.

TGR2A—Timer General Register 2A**H'FF38****TPU2****TGR2B—Timer General Register 2B****H'FF3A****TPU2**

Bit	15	14	13	12	11	10	9	8	7	6	5	4	3	2	1	0
	<input type="checkbox"/>	<input type="checkbox"/>	<input type="checkbox"/>	<input type="checkbox"/>	<input type="checkbox"/>	<input type="checkbox"/>	<input type="checkbox"/>	<input type="checkbox"/>	<input type="checkbox"/>	<input type="checkbox"/>	<input type="checkbox"/>	<input type="checkbox"/>	<input type="checkbox"/>	<input type="checkbox"/>	<input type="checkbox"/>	<input type="checkbox"/>
Initial value	1	1	1	1	1	1	1	1	1	1	1	1	1	1	1	1
Read/Write	R/W	R/W	R/W	R/W	R/W	R/W	R/W	R/W	R/W	R/W	R/W	R/W	R/W	R/W	R/W	R/W

TCSR0—Timer Control/Status Register 0

H'FF74(W), H'FF74(R)

WDT0

Bit	7	6	5	4	3	2	1	0
	OVF	WT/IT	TME	—	—	CKS2	CKS1	CKS0
Initial value	0	0	0	1	1	0	0	0
Read/Write	R/(W)*	R/W	R/W	—	—	R/W	R/W	R/W

Clock Select 2 to 0

CKS2	CKS1	CKS0	Clock	Overflow Period* (where $\phi = 20$ MHz)
0	0	0	$\phi/2$	25.6 μ s
		1	$\phi/64$	819.2 μ s
	1	0	$\phi/128$	1.6 ms
		1	$\phi/512$	6.6 ms
1	0	0	$\phi/2048$	26.2 ms
		1	$\phi/8192$	104.9 ms
	1	0	$\phi/32768$	419.4 ms
		1	$\phi/131072$	1.68 s

Note: * An overflow period is the time interval between the start of counting up from H'00 on the TCNT and the occurrence of a TCNT overflow.

Timer Enable

0	TCNT is initialized to H'00 and halted
1	TCNT counts

Timer Mode Select

0	Interval timer mode: WDT0 requests an interval timer interrupt (WOVI) from the CPU when the TCNT overflows
1	Watchdog timer mode: A reset is issued when the TCNT overflows if the RSTE bit of RSTCSR is set to 1*

Note: * For details see section 12.2.3, Reset Control/Status Register (RSTCSR).

Overflow Flag

0	[Clearing conditions] <ul style="list-style-type: none"> Write 0 in the TME bit (Only applies to WDT1) Read TCSR* when OVF = 1, then write 0 in OVF
1	[Setting condition] <ul style="list-style-type: none"> When TCNT overflows (changes from H'FF to H'00) (When internal reset request generation is selected in watchdog timer mode, OVF is cleared automatically by the internal reset)

Note: * When interval timer interrupts are disabled and OVF is polled, read the OVF = 1 state at least twice.

Notes: TCSR0 register differs from other registers in being more difficult to write to. For details see section 12.2.4, Notes on Register Access.

* Only 0 can be written, to clear the flag.

TCNT0—Timer Counter 0**H'FF74(W), H'FF75(R)****WDT0**

Bit	7	6	5	4	3	2	1	0
Initial value	0	0	0	0	0	0	0	0
Read/Write	R/W	R/W	R/W	R/W	R/W	R/W	R/W	R/W

Up-counter

Note: TCNT0 register differs from other registers in being more difficult to write to.
For details see section 12.2.4, Notes on Register Access.

RSTCSR—Reset Control/Status Register**H'FF76(W), H'FF77(R)****WDT0**

Bit	7	6	5	4	3	2	1	0
Initial value	0	0	0	0	0	0	0	0
Read/Write	R/(W)*	R/W	R/W	—	—	—	—	—

Reset Select

0	Reset
1	Do not set

Reset Enable

0	Reset signal is not generated if TCNT overflows*
1	Reset signal is generated if TCNT overflows

Note: * The modules within the H8S/2646 are not reset, but TCNT and TCSR within the WDT are reset.

Watchdog Overflow Flag

0	[Clearing condition] • Cleared by reading RSTCSR when WOVF = 1, then writing 0 to WOVF
1	[Setting condition] • Set when TCNT overflows (changed from H'FF to H'00) during watchdog timer operation

Notes: RSTCSR register differs from other registers in being more difficult to write to.
For details see section 12.2.4, Notes on Register Access.

* Can only be written with 0 for flag clearing.

SMR0—Serial Mode Register 0	H'FF78	SCI0
SMR1—Serial Mode Register 1	H'FF80	SCI1
SMR2—Serial Mode Register 2	H'FF88	SCI2

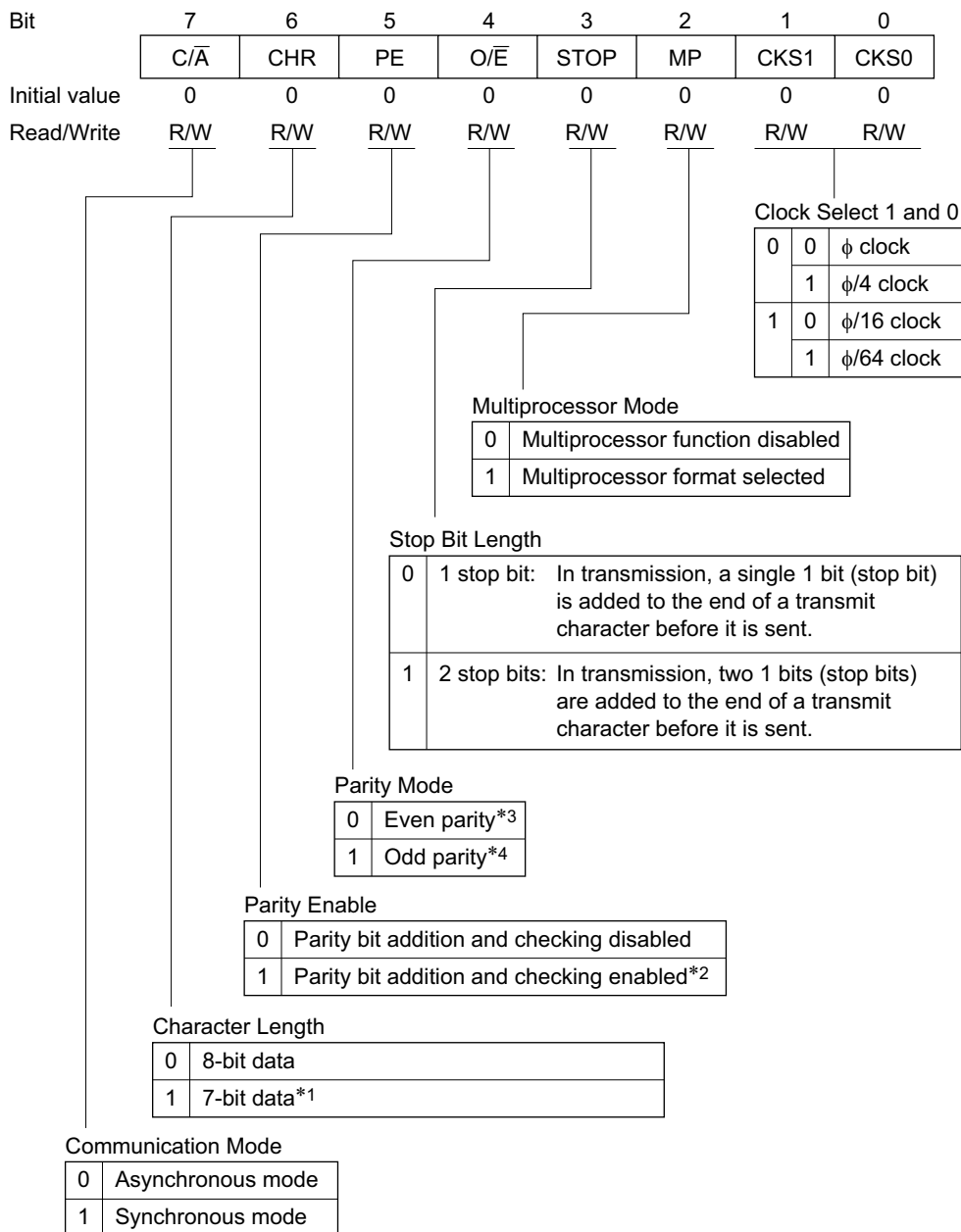

- Notes:
1. When 7-bit data is selected, the MSB (bit 7) of TDR is not transmitted, and it is not possible to choose between LSB-first or MSB-first transfer.
 2. When the PE bit is set to 1, the parity (even or odd) specified by the O/ \bar{E} bit is added to transmit data before transmission. In reception, the parity bit is checked for the parity (even or odd) specified by the O/ \bar{E} bit.
 3. When even parity is set, parity bit addition is performed in transmission so that the total number of 1 bits in the transmit character plus the parity bit is even.
In reception, a check is performed to see if the total number of 1 bits in the receive character plus the parity bit is even.
 4. When odd parity is set, parity bit addition is performed in transmission so that the total number of 1 bits in the transmit character plus the parity bit is odd.
In reception, a check is performed to see if the total number of 1 bits in the receive character plus the parity bit is odd.

ICCR0—I²C Bus Control Register

H'FF78

IIC0

ICCR1—I²C Bus Control Register

H'FF80

IIC1

Bit	7	6	5	4	3	2	1	0
	ICE	IEIC	MST	TRS	ACKE	BBSY	IRIC	SCP
Initial value	0	0	0	0	0	0	0	0
R/W	R/W	R/W	R/W	R/W	R/W	R/W	R/(W)*	R/W

Start condition/stop condition prohibit	
0	Writing 0 issues a start or stop condition, in combination with the BBSY flag
1	Reading always returns a value of 1 Writing is ignored

I ² C Bus interface interrupt request flag	
0	Waiting for transfer, or transfer in progress
1	Interrupt requested

Note: * For details see section 15.2.5, I²C Bus Control Register.

Bus busy	
0	Bus is free [Clearing condition] • When a stop condition is detected
1	Bus is free [Clearing condition] • When a stop condition is detected

Acknowledge bit judgement selection	
0	The value of the acknowledge bit is ignored, and continuous transfer is performed
1	If the acknowledge bit is 1, continuous transfer is interrupted

Master/slave select, transmit/receive select		
0	0	Slave receive mode
	1	Slave transmit mode
1	0	Master receive mode
	1	Master transmit mode

Note: * For details see section 15.2.5, I²C Bus Control Register.

I ² C Bus Interface Interrupt Enable	
0	Interrupts disabled
1	Interrupts enabled

I ² C Bus Interface Enable	
0	I ² C bus interface module disabled, with SCL and SDA signal pins set to port function I ² C bus interface module internal states initialized SAR and SARX can be accessed
1	I ² C bus interface module enabled for transfer operations (pins SCL and SCA are driving the bus) ICMR and ICDR can be accessed

Notes: This register is valid only on the H8S/2638, H8S/2639, or H8S/2630 with the I²C bus interface option added.

* Only 0 can be written, for flag clearing.

SMR0—Serial Mode Register 0

H'FF78

Smart Card Interface 0

SMR1—Serial Mode Register 1

H'FF80

Smart Card Interface 1

SMR2—Serial Mode Register 2

H'FF88

Smart Card Interface 2

Bit	7	6	5	4	3	2	1	0
	GM	BLK	PE	O/E	BCP1	BCP0	CKS1	CKS0
Initial value	0	0	0	0	0	0	0	0
Read/Write	R/W	R/W	R/W	R/W	R/W	R/W	R/W	R/W

Clock Select 1 and 0

0	0	ϕ clock
	1	$\phi/4$ clock
1	0	$\phi/16$ clock
	1	$\phi/64$ clock

Basic Clock Pulse

0	0	32 clock periods
	1	64 clock periods
1	0	372 clock periods
	1	256 clock periods

Parity Mode

0	Even parity*2
1	Odd parity*3

Parity Enable

0	Parity bit addition and checking disabled
1	Parity bit addition and checking enabled*1

Block Transfer Mode

0	Normal Smart Card interface mode operation <ul style="list-style-type: none"> • Error signal transmission/detection and automatic data retransmission performed • TXI interrupt generated by TEND flag • TEND flag set 12.5 etu after start of transmission (11.0 etu in GSM mode)
1	Block transfer mode operation <ul style="list-style-type: none"> • Error signal transmission/detection and automatic data retransmission not performed • TXI interrupt generated by TDRE flag • TEND flag set 11.5 etu after start of transmission (11.0 etu in GSM mode)

Note: etu: Elementary Time Unit (time for transfer of 1 bit)

GSM Mode

0	Normal smart card interface mode operation <ul style="list-style-type: none"> • TEND flag generation 12.5 etu (11.5 etu in block transfer mode) after beginning of start bit • Clock output ON/OFF control only
1	GSM mode smart card interface mode operation <ul style="list-style-type: none"> • TEND flag generation 11.0 etu after beginning of start bit • High/Low fixing control possible in addition to clock output ON/OFF control (set by SCR)

Note: etu: Elementary Time Unit (time for transfer of 1 bit)

Notes: When the smart card interface is used, be sure to make the 1 setting shown for bit 5.

1. When the PE bit is set to 1, the parity (even or odd) specified by the O/\bar{E} bit is added to transmit data before transmission. In reception, the parity bit is checked for the parity (even or odd) specified by the O/\bar{E} bit.
2. When even parity is set, parity bit addition is performed in transmission so that the total number of 1 bits in the transmit character plus the parity bit is even.
In reception, a check is performed to see if the total number of 1 bits in the receive character plus the parity bit is even.
3. When odd parity is set, parity bit addition is performed in transmission so that the total number of 1 bits in the transmit character plus the parity bit is odd.
In reception, a check is performed to see if the total number of 1 bits in the receive character plus the parity bit is odd.

BRR0—Bit Rate Register 0**H'FF79****SCI0, Smart Card Interface****0**

Bit	7	6	5	4	3	2	1	0
Initial value	1	1	1	1	1	1	1	1
Read/Write	R/W	R/W	R/W	R/W	R/W	R/W	R/W	R/W

|
Set the serial transmit/receive bit rate

Note: For details see section 13.2.8, Bit Rate Register (BRR).

ICSR0— I^2C Bus Status Register

H'FF79

IIC0

ICSR1— I^2C Bus Status Register

H'FF81

IIC1

Bit	7	6	5	4	3	2	1	0
	ESTP	STOP	IRTR	AASX	AL	AAS	ADZ	ACKB
Initial value :	0	0	0	0	0	0	0	0
R/W :	R/(W)*	R/(W)*	R/(W)*	R/(W)*	R/(W)*	R/(W)*	R/(W)*	R/W
							Acknowledge bit 0 When receiving, 0 is output at acknowledge output timing. When transmitting, this bit shows that an acknowledge (0) has not been sent from the receiving device. 1 When receiving, 1 is output at acknowledge output timing. When transmitting, this bit shows that an acknowledge (1) has been sent from the receiving device.	
							General call address confirmation flag 0 General call address not confirmed [Clearings] (1) When data is written to ICDR (when sending), or when data is read from ICDR (when receiving); (2) When 0 is written after reading ADZ=1; (3) In master mode. 1 General call address confirmation [Setting] • When general call address is detected is in slave receive mode and FSX = 0 or FS = 0.	
							Slave address confirmation flag 0 Slave address or general call address not confirmed [Clearings] (1) When data is written to ICDR (when sending), or when data is read from ICDR (when receiving); (2) When 0 is written after reading AAS=1; (3) In master mode. 1 Slave address or general call address confirmed [Setting] • When slave address or general call address is detected in slave receive mode and FS = 0.	
							Arbitration lost flag 0 Secure bus. [Clearings] (1) When data is written to ICDR (when sending), or when data is read (when receiving); (2) When 0 is written after reading AL=1. 1 Bus arbitration lost [Settings] (1) When there is a mismatch between internal SDA and SDA pin at rise in SCL in master transmit mode; (2) When the internal SCL level is HIGH at the fall in SCL in master transmit mode.	
							2nd slave address confirmation flag 0 2nd slave address not confirmed [Clearings] (1) When 0 is written after reading AASX=1; (2) When start conditions are detected; (3) In master mode. 1 2nd slave address confirmed [Setting] • When 2nd slave address is detected in slave receive mode and FSX = 0.	
							I ² C bus interface continuous transmit and receive interrupt request flag 0 Transmit wait state, or transmitting [Clearings] (1) When 0 written after reading IRTR=1; (2) When IRIC flag is cleared to 0. 1 Continuous transmit state [Settings] • In I ² C bus interface slave mode When 1 is set in TDRE or RDRF flag when AASX=1. • In other than I ² C bus interface slave mode When TDRE or RDRF flag is set to 1.	
							Normal end condition detection flag 0 No normal end condition [Clearings] (1) When 0 is written after reading STOP=1; (2) When IRIC flag is cleared to 0. 1 Normal end condition detected in slave mode in I ² C bus format [Setting] On detection of stop condition on completion of sending frame. • No meaning when in other than slave mode in I ² C bus format	
							Error stop condition detection flag 0 No error stop condition [Clearings] (1) When 0 written after reading ESTP=1; (2) When IRIC flag is cleared to 0. 1 Error stop condition detected in slave mode in I ² C bus format [Setting] On detection of stop condition while sending frame. • No meaning when in other than slave mode in I ² C bus format	

Notes: This register is valid only on the H8S/2638, H8S/2639, or H8S/2630 with the I²C bus interface option added.

* Only 0 can be written to these bits (to clear these flags).

SCR0—Serial Control Register 0

H'FF7A

SCIO

SCR1—Serial Control Register 1

H'FF82

SCI1

SCR2—Serial Control Register 2

H'FF8A

SCI2

Bit	7	6	5	4	3	2	1	0
	TIE	RIE	TE	RE	MPIE	TEIE	CKE1	CKE0
Initial value	0	0	0	0	0	0	0	0
Read/Write	R/W	R/W	R/W	R/W	R/W	R/W	R/W	R/W

Clock Enable 1 and 0

CKE1	CKE0	Mode	Function
0	0	Asynchronous mode	Internal clock/SCK pin functions as I/O port
		Clocked asynchronous mode	Internal clock/SCK pin functions as serial clock output
1	0	Asynchronous mode	Internal clock/SCK pin functions as clock output*9
		Clocked synchronous mode	Internal clock/SCK pin functions as serial clock output
1	0	Asynchronous mode	External clock/SCK pin functions as clock input*10
		Clocked synchronous mode	External clock/SCK pin functions as serial clock input
1	1	Asynchronous mode	External clock/SCK pin functions as clock input*10
		Clocked synchronous mode	External clock/SCK pin functions as serial clock input

Transmit End Interrupt Enable

0	Transmit-end interrupt (TEI) request disabled*8
1	Transmit-end interrupt (TEI) request enabled*8

Multiprocessor Interrupt Enable

0	Multiprocessor interrupts disabled (normal reception mode) [Clearing conditions] <ul style="list-style-type: none"> When the MPIE bit is cleared to 0 When data with MPB = 1 is received
1	Multiprocessor interrupts enabled*7 Receive interrupt (RXI) requests, receive-error interrupt (ERI) requests, and setting of the RDRF, FER, and ORER flags in SSR are disabled until data with the multiprocessor bit set to 1 is received

Transmit Interrupt Enable

0	Transmit-data-empty interrupt (TXI) request disabled*1
1	Transmit-data-empty interrupt (TXI) request enabled

Receive Interrupt Enable

0	Receive-data-full interrupt (RXI) request and receive-error interrupt (ERI) request disabled*2
1	Receive-data-full interrupt (RXI) request and receive-error interrupt (ERI) request enabled

Receive Enable

0	Reception disabled*5
1	Reception enabled*6

Transmit Enable

0	Transmission disabled*3
1	Transmission enabled*4

- Notes:
1. TXI interrupt request cancellation can be performed by reading 1 from the TDRE flag, then clearing it to 0, or clearing the TIE bit to 0.
 2. RXI and ERI interrupt request cancellation can be performed by reading 1 from the RDRF flag, or the FER, PER, or ORER flag, then clearing the flag to 0, or clearing the RIE bit to 0.
 3. The TDRE flag in SSR is fixed at 1.
 4. In this state, serial transmission is started when transmit data is written to TDR and the TDRE flag in SSR is cleared to 0.
SMR setting must be performed to decide the transfer format before setting the TE bit to 1.
 5. Clearing the RE bit to 0 does not affect the RDRF, FER, PER, and ORER flags, which retain their states.
 6. Serial reception is started in this state when a start bit is detected in asynchronous mode or serial clock input is detected in clocked synchronous mode.
SMR setting must be performed to decide the transfer format before setting the RE bit to 1.
 7. When receive data including MPB = 0 is received, receive data transfer from RSR to RDR, receive error detection, and setting of the RDRF, FER, and ORER flags in SSR, is not performed. When receive data including MPB = 1 is received, the MPB bit in SSR is set to 1, the MPIE bit is cleared to 0 automatically, and generation of RXI and ERI interrupts (when the TIE and RIE bits in SCR are set to 1) and FER and ORER flag setting is enabled.
 8. TEI cancellation can be performed by reading 1 from the TDRE flag in SSR, then clearing it to 0 and clearing the TEND flag to 0, or clearing the TEIE bit to 0.
 9. Outputs a clock of the same frequency as the bit rate.
 10. Inputs a clock with a frequency 16 times the bit rate.

SCR0—Serial Control Register 0

H'FF7A

Smart Card Interface 0

SCR1—Serial Control Register 1

H'FF82

Smart Card Interface 1

SCR2—Serial Control Register 2

H'FF8A

Smart Card Interface 2

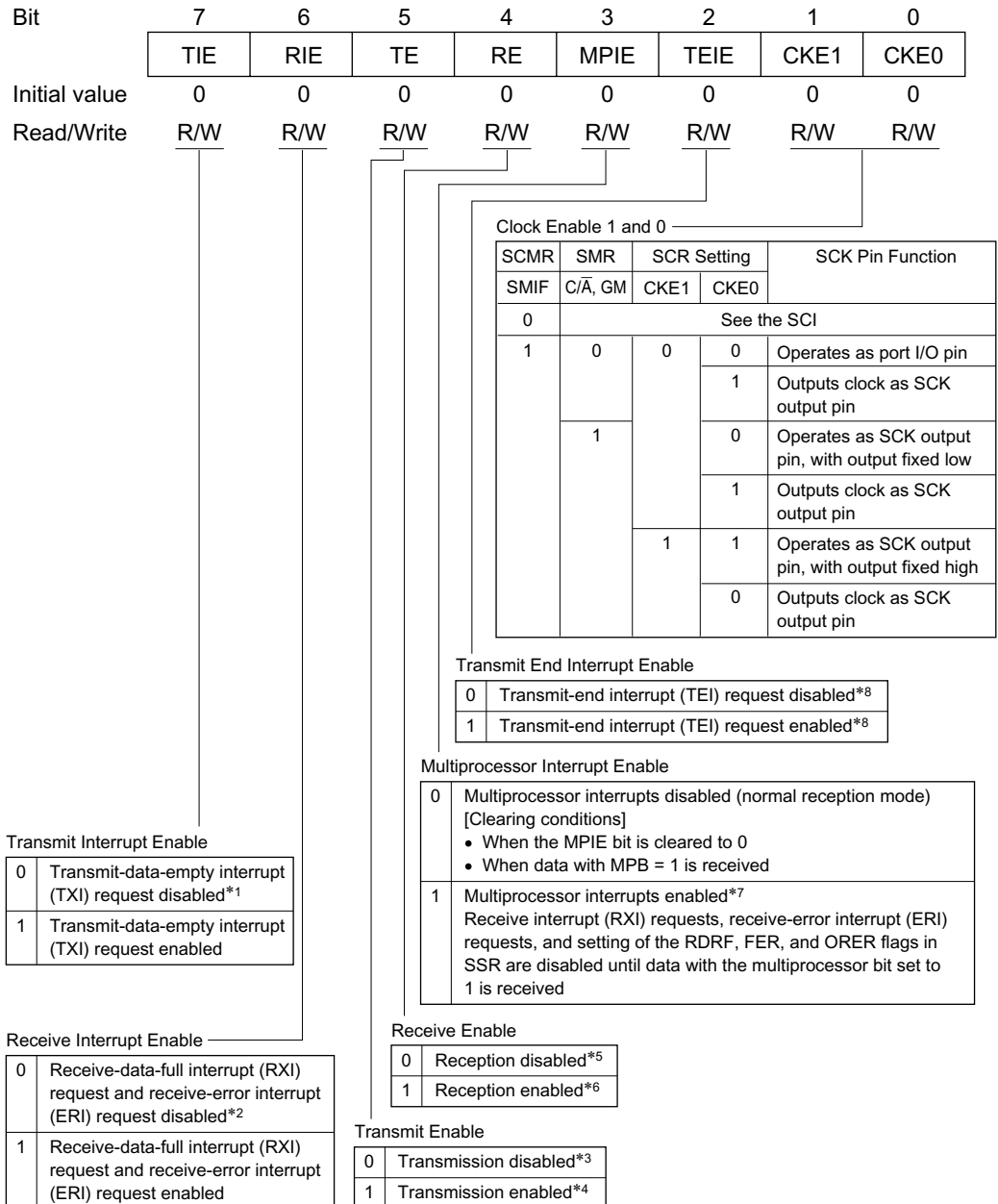

- Notes:
1. TXI interrupt request cancellation can be performed by reading 1 from the TDRE flag, then clearing it to 0, or clearing the TIE bit to 0.
 2. RXI and ERI interrupt request cancellation can be performed by reading 1 from the RDRF flag, or the FER, PER, or ORER flag, then clearing the flag to 0, or clearing the RIE bit to 0.
 3. The TDRE flag in SSR is fixed at 1.
 4. In this state, serial transmission is started when transmit data is written to TDR and the TDRE flag in SSR is cleared to 0.
SMR setting must be performed to decide the transfer format before setting the TE bit to 1.
 5. Clearing the RE bit to 0 does not affect the RDRF, FER, PER, and ORER flags, which retain their states.
 6. Serial reception is started in this state when a start bit is detected in asynchronous mode or serial clock input is detected in clocked synchronous mode.
SMR setting must be performed to decide the transfer format before setting the RE bit to 1.
 7. When receive data including MPB = 0 is received, receive data transfer from RSR to RDR, receive error detection, and setting of the RDRF, FER, and ORER flags in SSR, is not performed. When receive data including MPB = 1 is received, the MPB bit in SSR is set to 1, the MPIE bit is cleared to 0 automatically, and generation of RXI and ERI interrupts (when the TIE and RIE bits in SCR are set to 1) and FER and ORER flag setting is enabled.
 8. TEI cancellation can be performed by reading 1 from the TDRE flag in SSR, then clearing it to 0 and clearing the TEND flag to 0, or clearing the TEIE bit to 0.

TDR0—Transmit Data Register 0 **H'FF7B** **SCI0, Smart Card Interface 0**

Bit	7	6	5	4	3	2	1	0
Initial value	1	1	1	1	1	1	1	1
Read/Write	R/W	R/W	R/W	R/W	R/W	R/W	R/W	R/W

|
Store serial transmit data

SSR0—Serial Status Register 0

H'FF7C

SCI0

SSR1—Serial Status Register 1

H'FF84

SCI1

SSR2—Serial Status Register 2

H'FF8C

SCI2

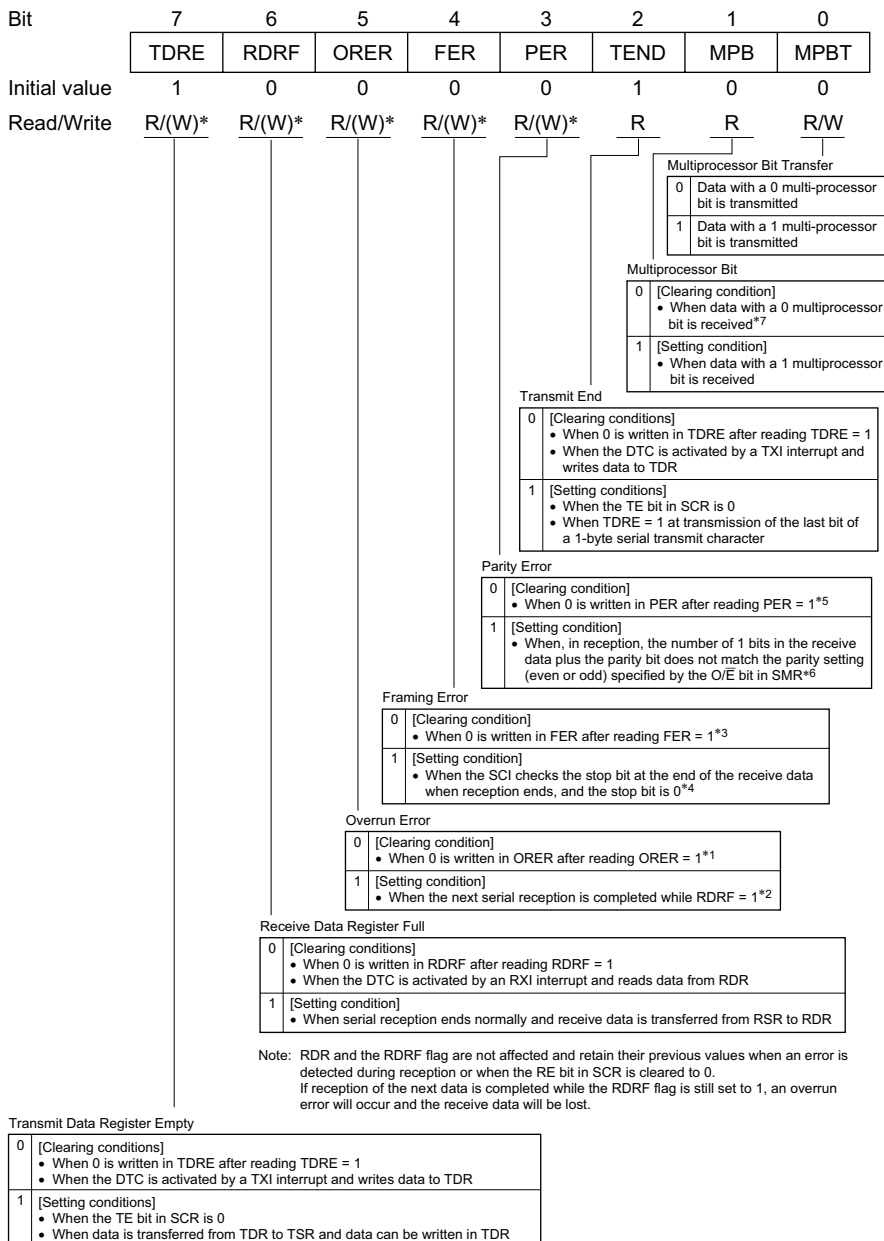

Notes: * Only 0 can be written, to clear the flag.

1. The ORER flag is not affected and retains its previous state when the RE bit in SCR is cleared to 0.
2. The receive data prior to the overrun error is retained in RDR, and the data received subsequently is lost. Also, subsequent serial reception cannot be continued while the ORER flag is set to 1. In clocked synchronous mode, serial transmission cannot be continued, either.
3. The FER flag is not affected and retains its previous state when the RE bit in SCR is cleared to 0.
4. In 2-stop-bit mode, only the first stop bit is checked for a value of 0; the second stop bit is not checked. If a framing error occurs, the receive data is transferred to RDR but the RDRF flag is not set. Also, subsequent serial reception cannot be continued while the FER flag is set to 1. In clocked synchronous mode, serial transmission cannot be continued, either.
5. The PER flag is not affected and retains its previous state when the RE bit in SCR is cleared to 0.
6. If a parity error occurs, the receive data is transferred to RDR but the RDRF flag is not set. Also, subsequent serial reception cannot be continued while the PER flag is set to 1. In clocked synchronous mode, serial transmission cannot be continued, either.
7. Retains its previous state when the RE bit in SCR is cleared to 0 with multiprocessor format.

SSR0—Serial Status Register 0

H'FF7C

Smart Card Interface 0

SSR1—Serial Status Register 1

H'FF84

Smart Card Interface 1

SSR2—Serial Status Register 2

H'FF8C

Smart Card Interface 2

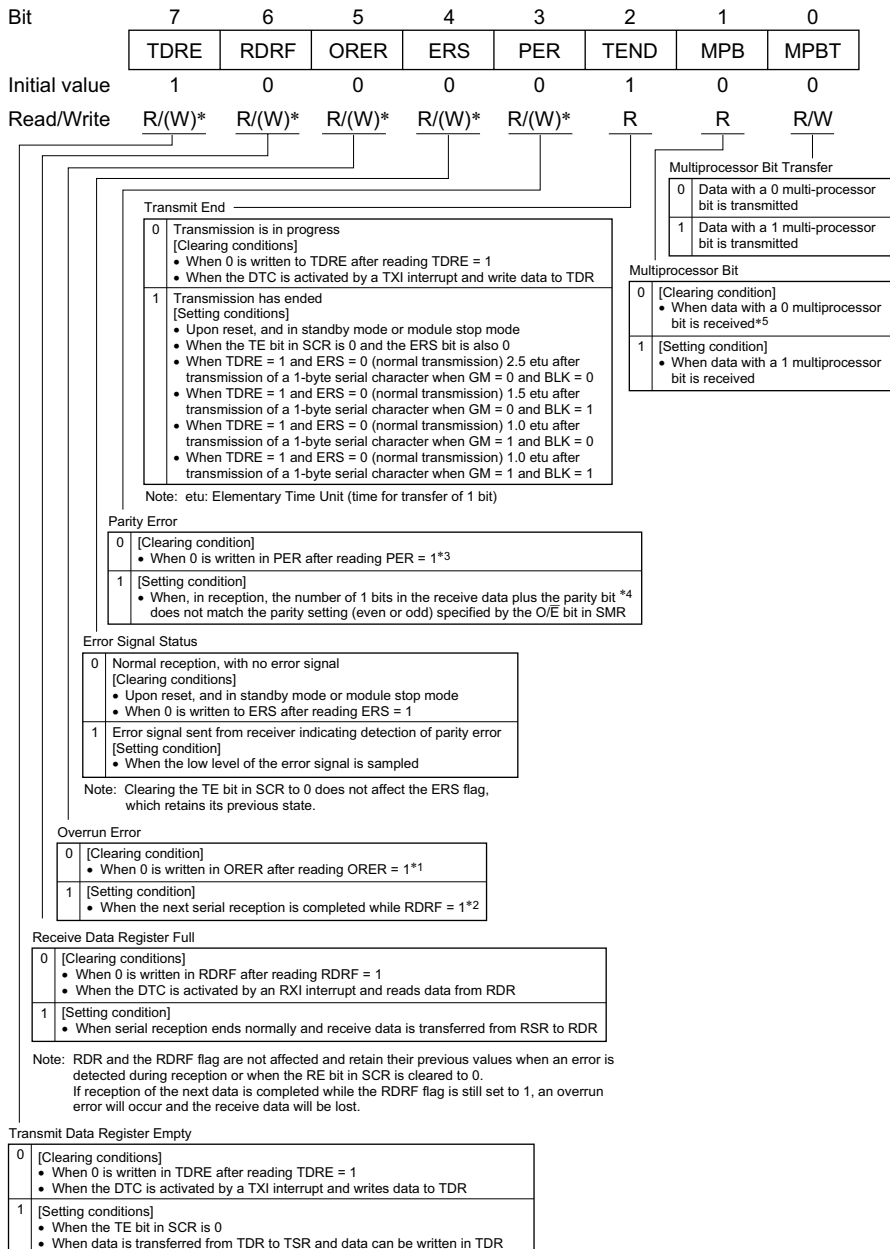

Notes: * Only 0 can be written, to clear the flag.

1. The ORER flag is not affected and retains its previous state when the RE bit in SCR is cleared to 0.
2. The receive data prior to the overrun error is retained in RDR, and the data received subsequently is lost. Also, subsequent serial reception cannot be continued while the ORER flag is set to 1. In clocked synchronous mode, serial transmission cannot be continued, either.
3. The PER flag is not affected and retains its previous state when the RE bit in SCR is cleared to 0.
4. If a parity error occurs, the receive data is transferred to RDR but the RDRF flag is not set. Also, subsequent serial reception cannot be continued while the PER flag is set to 1. In clocked synchronous mode, serial transmission cannot be continued, either.
5. Retains its previous state when the RE bit in SCR is cleared to 0 with multiprocessor format.

RDR0—Receive Data Register 0 **H'FF7D** **SCI0, Smart Card Interface 0**

Bit	7	6	5	4	3	2	1	0
Initial value	0	0	0	0	0	0	0	0
Read/Write	R	R	R	R	R	R	R	R

|
Store serial receive data

SCMR0—Smart Card Mode Register 0

H'FF7E

SCIO, Smart Card Interface

0

Bit	7	6	5	4	3	2	1	0
	—	—	—	—	SDIR	SINV	—	SMIF
Initial value	1	1	1	1	0	0	1	0
Read/Write	—	—	—	—	R/W	R/W	—	R/W

Smart Card Interface Mode Select

0	Operates as normal SCI (smart card interface function disabled)
1	Smart card interface function enabled

Smart Card Interface Data Invert

0	TDR contents are transmitted without modification Receive data is stored in RDR without modification
1	TDR contents are inverted before being transmitted Receive data is stored in RDR in inverted form

Smart Card Interface Data Transfer Direction

0	TDR contents are transmitted LSB-first Receive data is stored in RDR LSB-first
1	TDR contents are transmitted MSB-first Receive data is stored in RDR MSB-first

ICDR0—I²C Bus Data Register**H'FF7E****IIC0****ICDR1—I²C Bus Data Register****H'FF86****IIC1**

Bit	:	7	6	5	4	3	2	1	0
		ICDR7	ICDR6	ICDR5	ICDR4	ICDR3	ICDR2	ICDR1	ICDR0
Initial value:		—	—	—	—	—	—	—	—
R/W	:	R/W	R/W	R/W	R/W	R/W	R/W	R/W	R/W

ICDRR

Bit	:	7	6	5	4	3	2	1	0
		ICDRR7	ICDRR6	ICDRR5	ICDRR4	ICDRR3	ICDRR2	ICDRR1	ICDRR0
Initial value:		—	—	—	—	—	—	—	—
R/W	:	R	R	R	R	R	R	R	R

ICDRS

Bit	:	7	6	5	4	3	2	1	0
		ICDRS7	ICDRS6	ICDRS5	ICDRS4	ICDRS3	ICDRS2	ICDRS1	ICDRS0
Initial value:		—	—	—	—	—	—	—	—
R/W	:	—	—	—	—	—	—	—	—

ICDRT

Bit	:	7	6	5	4	3	2	1	0
		ICDRT7	ICDRT6	ICDRT5	ICDRT4	ICDRT3	ICDRT2	ICDRT1	ICDRT0
Initial value:		—	—	—	—	—	—	—	—
R/W	:	W	W	W	W	W	W	W	W

TDRE, RDRF (internal flag)

Bit	:		
		TDRE	RDRF
Initial value:		0	0
R/W	:	—	—

Note: This register is valid only on the H8S/2638, H8S/2639, or H8S/2630 with the I²C bus interface option added.

SARX0—2nd Slave Address Register**H'FF7E****IIC0****SARX1—2nd Slave Address Register****H'FF86****IIC1**

Bit	:	7	6	5	4	3	2	1	0
		SVAX6	SVAX5	SVAX4	SVAX3	SVAX2	SVAX1	SVAX0	FSX
Initial value	:	0	0	0	0	0	0	0	1
R/W	:	R/W	R/W	R/W	R/W	R/W	R/W	R/W	R/W
		 2nd slave address						 Format select X	

Note: This register is valid only on the H8S/2638, H8S/2639, or H8S/2630 with the I²C bus interface option added.

ICMR0—I²C Bus Mode Register

H'FF7F

IIC0

ICMR1—I²C Bus Mode Register

H'FF87

IIC1

Bit	:	7	6	5	4	3	2	1	0
		MLS	WAIT	CKS2	CKS1	CKS0	BC2	BC1	BC0
Initial value	:	0	0	0	0	0	0	0	0
R/W	:	R/W	R/W	R/W	R/W	R/W	R/W	R/W	R/W

Bit counter

Bit 2	Bit 1	Bit 0	Bit/frame	
BC2	BC1	BC0	Clock sync serial format	PC bus format
0	0	0	8	9
		1	1	2
	1	0	2	3
		1	3	4
1	0	0	4	5
		1	5	6
	1	0	6	7
		1	7	8

Transmit clock select

SCRX bit 5, 6	Bit 5	Bit 4	Bit 3	Clock	Transfer rate				
					$\phi = 5$ MHz	$\phi = 8$ MHz	$\phi = 10$ MHz	$\phi = 16$ MHz	$\phi = 20$ MHz
IICX	0	0	0	$\phi/28$	179kHz	286 kHz	357 kHz	571 kHz*	714 kHz*
			1	$\phi/40$	125kHz	200 kHz	250 kHz	400 kHz	500 kHz*
		1	0	$\phi/48$	104kHz	167 kHz	208 kHz	333 kHz	417 kHz*
			1	$\phi/64$	78.1kHz	125 kHz	156 kHz	250 kHz	313 kHz
	1	0	0	$\phi/80$	62.5kHz	100 kHz	125 kHz	200 kHz	250 kHz
			1	$\phi/100$	50.0kHz	80.0 kHz	100 kHz	160 kHz	200 kHz
		1	0	$\phi/112$	44.6kHz	71.4 kHz	89.3 kHz	143 kHz	179 kHz
			1	$\phi/128$	39.1kHz	62.5 kHz	78.1 kHz	125 kHz	156 kHz
1	0	0	0	$\phi/56$	89.3kHz	143 kHz	179 kHz	286 kHz	357 kHz
			1	$\phi/80$	62.5kHz	100 kHz	125 kHz	200 kHz	250 kHz
		1	0	$\phi/96$	52.1kHz	83.3 kHz	104 kHz	167 kHz	208 kHz
			1	$\phi/128$	39.1kHz	62.5 kHz	78.1 kHz	125 kHz	156 kHz
	1	0	0	$\phi/160$	31.3kHz	50.0 kHz	62.5 kHz	100 kHz	125 kHz
			1	$\phi/200$	25.0kHz	40.0 kHz	50.0 kHz	80.0 kHz	100 kHz
		1	0	$\phi/224$	22.3kHz	35.7 kHz	44.6 kHz	71.4 kHz	89.3 kHz
			1	$\phi/256$	19.5kHz	31.3 kHz	39.1 kHz	62.5 kHz	78.1 kHz

Note: * These rates are outside the ranges stipulated in the I²C bus interface specifications (normal mode: max. 100 kHz, high-speed mode: max. 400 kHz).

Wait insert bit

0	Send data followed by acknowledge bit.
1	Insert wait between data and acknowledge bit.

MSB-first/LSB-first select

0	MSB first
1	LSB first

Note: This register is valid only on the H8S/2638, H8S/2639, or H8S/2630 with the I²C bus interface option added.

SAR0—Slave Address Register**H'FF7F****IIC0****SAR1—Slave Address Register****H'FF87****IIC1**

Bit	:	7	6	5	4	3	2	1	0
		SVA6	SVA5	SVA4	SVA3	SVA2	SVA1	SVA0	FS
Initial value	:	0	0	0	0	0	0	0	0
R/W	:	R/W	R/W	R/W	R/W	R/W	R/W	R/W	R/W

Slave address

Format select

DDCSWR bit 6	SAR bit 0	SARX bit 0	Operating mode
SW	FS	FSX	
0	0	0	I ² C bus format • SAR and SARX slave addresses recognized
		1	I ² C bus format (initial value) • SAR slave address recognized • SARX slave address ignored
	1	0	I ² C bus format • SAR slave address ignored • SARX slave address recognized
		1	Synchronous serial format • SAR and SARX slave addresses ignored
1	—	—	• Must not be set.

BRR1—Bit Rate Register 1**H'FF81****SCI1, Smart Card Interface****1**

Bit	7	6	5	4	3	2	1	0
Initial value	1	1	1	1	1	1	1	1
Read/Write	R/W	R/W	R/W	R/W	R/W	R/W	R/W	R/W

Set the serial transmit/receive bit rate

Note: For details see section 13.2.8, Bit Rate Register (BRR).

TDR1—Transmit Data Register 1**H'FF83****SCI1, Smart Card Interface****1**

Bit	7	6	5	4	3	2	1	0
Initial value	1	1	1	1	1	1	1	1
Read/Write	R/W	R/W	R/W	R/W	R/W	R/W	R/W	R/W

Store serial transmit data

RDR1—Receive Data Register 1**H'FF85****SCI1, Smart Card Interface 1**

Bit	7	6	5	4	3	2	1	0
Initial value	0	0	0	0	0	0	0	0
Read/Write	R	R	R	R	R	R	R	R

Store serial receive data

SCMR1—Smart Card Mode Register 1**H'FF86****SCI1, Smart Card Interface 1**

Bit	7	6	5	4	3	2	1	0
	—	—	—	—	SDIR	SINV	—	SMIF
Initial value	1	1	1	1	0	0	1	0
Read/Write	—	—	—	—	R/W	R/W	—	R/W

Smart Card Interface Mode Select

0	Operates as normal SCI (smart card interface function disabled)
1	Smart card interface function enabled

Smart Card Interface Data Invert

0	TDR contents are transmitted without modification Receive data is stored in RDR without modification
1	TDR contents are inverted before being transmitted Receive data is stored in RDR in inverted form

Smart Card Data Interface Transfer Direction

0	TDR contents are transmitted LSB-first Receive data is stored in RDR LSB-first
1	TDR contents are transmitted MSB-first Receive data is stored in RDR MSB-first

BRR2—Bit Rate Register 2**H'FF89****SCI2, Smart Card Interface****2**

Bit	7	6	5	4	3	2	1	0
Initial value	1	1	1	1	1	1	1	1
Read/Write	R/W	R/W	R/W	R/W	R/W	R/W	R/W	R/W

Set the serial transmit/receive bit rate

Note: For details see section 13.2.8, Bit Rate Register (BRR).

TDR2—Transmit Data Register 2**H'FF8B****SCI2, Smart Card Interface 2**

Bit	7	6	5	4	3	2	1	0
Initial value	1	1	1	1	1	1	1	1
Read/Write	R/W	R/W	R/W	R/W	R/W	R/W	R/W	R/W

Store serial transmit data

RDR2—Receive Data Register 2**H'FF8D****SCI2, Smart Card Interface 2**

Bit	7	6	5	4	3	2	1	0
Initial value	0	0	0	0	0	0	0	0
Read/Write	R	R	R	R	R	R	R	R

Store serial receive data

SCMR2—Smart Card Mode Register 2**H'FF8E****SCI2, Smart Card Interface 2**

Bit	7	6	5	4	3	2	1	0
	—	—	—	—	SDIR	SINV	—	SMIF
Initial value	1	1	1	1	0	0	1	0
Read/Write	—	—	—	—	R/W	R/W	—	R/W

Smart Card Interface Mode Select

0	Operates as normal SCI (smart card interface function disabled)
1	Smart card interface function enabled

Smart Card Interface Data Invert

0	TDR contents are transmitted without modification Receive data is stored in RDR without modification
1	TDR contents are inverted before being transmitted Receive data is stored in RDR in inverted form

Smart Card Interface Data Transfer Direction

0	TDR contents are transmitted LSB-first Receive data is stored in RDR LSB-first
1	TDR contents are transmitted MSB-first Receive data is stored in RDR MSB-first

ADDRA—A/D Data Register A**H'FF90****A/D Converter****ADDRB—A/D Data Register B****H'FF92****A/D Converter****ADDRC—A/D Data Register C****H'FF94****A/D Converter****ADDRD—A/D Data Register D****H'FF96****A/D Converter**

Bit	15	14	13	12	11	10	9	8	7	6	5	4	3	2	1	0
	AD9	AD8	AD7	AD6	AD5	AD4	AD3	AD2	AD1	AD0	—	—	—	—	—	—
Initial value	0	0	0	0	0	0	0	0	0	0	0	0	0	0	0	0
Read/Write	R	R	R	R	R	R	R	R	R	R	R	R	R	R	R	R

ADCSR—A/D Control/Status Register

H'FF98

A/D Converter

Bit	7	6	5	4	3	2	1	0
	ADF	ADIE	ADST	SCAN	CH3	CH2	CH1	CH0
Initial value	0	0	0	0	0	0	0	0
Read/Write	R/(W)*	R/W	R/W	R/W	R/W	R/W	R/W	R/W

Channel Select 2 to 0					
CH3	CH2	CH1	CH0	Single Mode (SCAN = 0)	Scan Mode (SCAN = 1)
0	0	0	0	AN0	AN0
			1	AN1	AN0, AN1
		1	0	AN2	AN0 to AN2
	1	0	1	AN3	AN0 to AN3
			0	AN4	AN4
		1	0	AN5	AN4, AN5
1	0	1	AN6	AN4 to AN6	
		1	AN7	AN4 to AN7	
	1	0	AN8	AN8	
		1	AN9	AN8, AN9	
		1	AN10	AN8 to AN10	
1	0	1	AN11	AN8 to AN11	
		0	Setting prohibited	Setting prohibited	
1	1	0	Setting prohibited	Setting prohibited	
		1	Setting prohibited	Setting prohibited	

Channel Select 3	
0	AN8 to AN11 are group 0 analog input pins
1	AN0 to AN3 are group 0 analog input pins, AN4 to AN7 are group 1 analog input pins

Scan Mode	
0	Single mode
1	Scan mode

A/D Start	
0	A/D conversion stopped
1	<ul style="list-style-type: none"> Single mode: A/D conversion is started. Cleared to 0 automatically when conversion on the specified channel ends Scan mode: A/D conversion is started. Conversion continues sequentially on the selected channels until ADST is cleared to 0 by software, a reset, or a transition to standby mode or module stop mode

A/D Interrupt Enable	
0	A/D conversion end interrupt (ADI) request disabled
1	A/D conversion end interrupt (ADI) request enabled

A/D End Flag	
0	[Clearing conditions] <ul style="list-style-type: none"> When 0 is written in the to ADF flag after reading ADF = 1 When the DTC is activated by an ADI interrupt, and ADDR is read
1	[Setting conditions] <ul style="list-style-type: none"> Single mode: When A/D conversion ends Scan mode: When A/D conversion ends on all specified channels

Note: * Only 0 can be written, to clear the flag.

ADCR—A/D Control Register

H'FF99

A/D Converter

Bit	7	6	5	4	3	2	1	0
	TRGS1	TRGS0	—	—	CKS1	CKS0	—	—
Initial value	0	0	1	1	0	0	1	1
Read/Write	R/W	R/W	—	—	R/W	R/W	—	—

Clock Select

0	0	Conversion time = 530 states (max.)
	1	Conversion time = 266 states (max.)
1	0	Conversion time = 134 states (max.)
	1	Conversion time = 68 states (max.)

Timer Trigger Select

0	0	A/D conversion start by software is enabled
	1	A/D conversion start by TPU conversion start trigger is enabled
1	0	Setting prohibited
	1	A/D conversion start by external trigger pin (ADTRG) is enabled

TCSR1—Timer Control/Status Register 1

H'FFA2(W), H'FFA2(R)

WDT1

Bit	7	6	5	4	3	2	1	0
	OVF	WT/IT	TME	PSS*2	RST/NMI	CKS2	CKS1	CKS0
Initial value	0	0	0	0	0	0	0	0
Read/Write	R/(W)*1	R/W	R/W	R/W	R/W	R/W	R/W	R/W

Clock Select 2 to 0

PSS	CKS2	CKS1	CKS0	Clock	Overflow Period*1 (where $\phi = 20$ MHz) (where $\phi\text{SUB}^2 = 32.768$ kHz)
0	0	0	0	$\phi/2$	25.6 μs
			1	$\phi/64$	819.2 μs
		1	0	$\phi/128$	1.6 ms
	1	0	1	$\phi/512$	6.6 ms
			0	$\phi/2048$	26.2 ms
		1	0	$\phi/8192$	104.9 ms
0	1	0	$\phi/32768$	419.4 ms	
		1	1	$\phi/131072$	1.68 s
		1	0	$\phi\text{SUB}/2^2$	15.6 ms
1	0	0	1	$\phi\text{SUB}/4^2$	31.3 ms
			0	$\phi\text{SUB}/8^2$	62.5 ms
		1	0	$\phi\text{SUB}/16^2$	125 ms
	1	0	0	$\phi\text{SUB}/32^2$	250 ms
			1	$\phi\text{SUB}/64^2$	500 ms
		1	0	$\phi\text{SUB}/128^2$	1 s
			1	$\phi\text{SUB}/256^2$	2 s

- Notes: 1. An overflow period is the time interval between the start of counting up from H'00 on the TCNT and the occurrence of a TCNT overflow.
2. Subclock functions (subactive mode, subsleep mode, and watch mode) are available in the U-mask, W-mask versions, and H8S/2635 Group only, but are not available in the other versions.

Reset or NMI

0	NMI request
1	Internal reset request

Prescaler Select

0	The TCNT counts frequency-division clock pulses of the ϕ based prescaler (PSM)
1	The TCNT counts frequency-division clock pulses of the ϕSUB^* -based prescaler (PSS)

Note: * Subclock functions (subactive mode, subsleep mode, and watch mode) are available in the U-mask, W-mask versions, and H8S/2635 Group only. These functions cannot be used with the other versions, and in them the PSS bit is reserved. Only 0 should be written to this bit.

Timer Enable

0	TCNT is initialized to H'00 and halted
1	TCNT counts

Timer Mode Select

0	Interval timer mode: WDT1 requests an interval timer interrupt (WOVI) from the CPU when the TCNT overflows
1	Watchdog timer mode: WDT1 requests a reset or an NMI interrupt from the CPU when the TCNT overflows

Overflow Flag

0	[Clearing conditions] • Write 0 in the TME bit (Only applies to WDT1) • Read TCSR* when OVF = 1, then write 0 in OVF
1	[Setting condition] • When TCNT overflows (changes from H'FF to H'00) (When internal reset request generation is selected in watchdog timer mode, OVF is cleared automatically by the internal reset)

Note: * When interval timer interrupts are disabled and OVF is polled, read the OVF = 1 state at least twice.

Notes: TCSR1 register differs from other registers in being more difficult to write to. For details see section 12.2.4, Notes on Register Access.

- Only 0 can be written, to clear the flag.
- Subclock functions (subactive mode, subsleep mode, and watch mode) are available in the U-mask, W-mask versions, and H8S/2635 Group only.

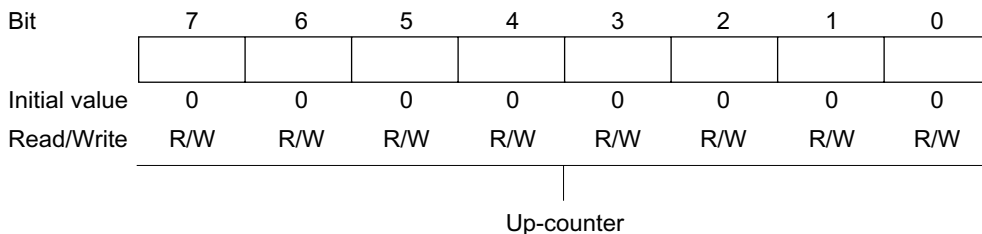
TCNT1—Timer Counter 1**H'FFA2(W), H'FFA3(R)****WDT1**

Note: TCNT1 register differs from other registers in being more difficult to write to.
For details see section 12.2.4, Notes on Register Access.

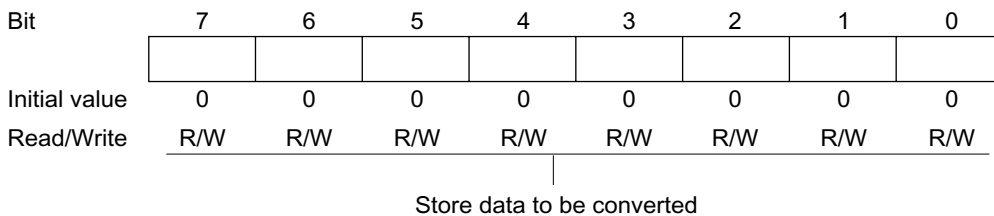
DADR0— D/A Data Register 0**H'FFA4****D/A0, 1****DADR1— D/A Data Register 1****H'FFA5****D/A0, 1**

Note: These registers are not available in the H8S/2635 and H8S/2634.

DACR01— D/A Control Register 01

H'FFA6

D/A0, 1

Bit	7	6	5	4	3	2	1	0
	DAOE1	DAOE0	DAE	—	—	—	—	—
Initial value	0	0	0	1	1	1	1	1
Read/Write	R/(W)*	R/W	R/W	—	—	—	—	—

D/A Enable

0	0	*	Disabled on channels 0 and 1
	1	0	Enabled on channel 0 Disabled on channel 1
		1	Enabled on channels 0 and 1
1	0	0	Disabled on channel 0 Enabled on channel 1
		1	Enabled on channels 0 and 1
	1	*	Enabled on channels 0 and 1

*: Don't care

D/A Output Enable 0

0	Analog output DA0 is disabled
1	D/A conversion is enabled on channel 0. Analog output DA0 is enabled

D/A Output Enable 1

0	Analog output DA1 is disabled
1	D/A conversion is enabled on channel 1. Analog output DA1 is enabled

Note: This register is not available in the H8S/2635 and H8S/2634.

FLMCR1—Flash Memory Control Register 1

H'FFA8

Flash Memory

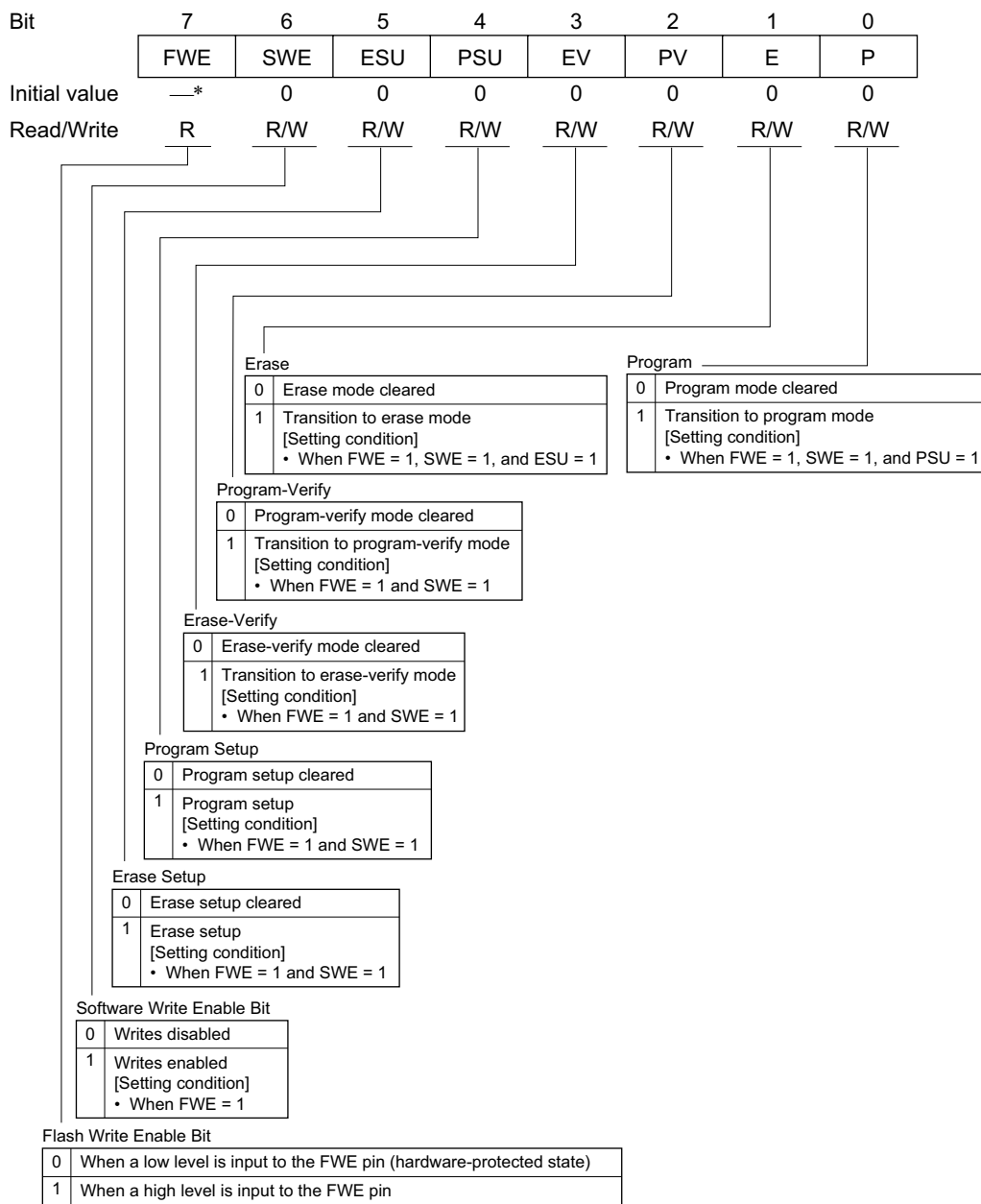

Note: * Determined by the state of the FWE pin.

FLMCR2—Flash Memory Control Register 2 **H'FFA9** **Flash Memory**

Bit	7	6	5	4	3	2	1	0
	FLER	—	—	—	—	—	—	—
Initial value	0	0	0	0	0	0	0	0
Read/Write	R	—	—	—	—	—	—	—

Flash Memory Error

0	Flash memory is operating normally Flash memory program/erase protection (error protection) is disabled [Clearing condition] • Power-on reset or hardware standby mode
1	An error has occurred during flash memory programming/erasing Flash memory program/erase protection (error protection) is enabled [Setting condition] • See section 21A.10.3, 21B.10.3, Error Protection

EBR1—Erase Block Register 1**H'FFAA****Flash Memory****EBR2—Erase Block Register 2****H'FFAB****Flash Memory****EBR1**

Bit	15	14	13	12	11	10	9	8
	EB7	EB6	EB5	EB4	EB3	EB2	EB1	EB0
Initial value	0	0	0	0	0	0	0	0
Read/Write	R/W	R/W	R/W	R/W	R/W	R/W	R/W	R/W

EBR2

Bit	7	6	5	4	3	2	1	0
	—	—	EB13*3	EB12*3	EB11*2	EB10*1	EB9	EB8
Initial value	0	0	0	0	0	0	0	0
Read/Write	R/W	R/W	R/W	R/W	R/W	R/W	R/W	R/W

Specify the flash memory erase area

• H8S/2636

Block (Size)	Addresses
EB0 (1 kbyte)	H'000000 to H'0003FF
EB1 (1 kbyte)	H'000400 to H'0007FF
EB2 (1 kbyte)	H'000800 to H'000BFF
EB3 (1 kbyte)	H'000C00 to H'000FFF
EB4 (28 kbytes)	H'001000 to H'007FFF
EB5 (16 kbytes)	H'008000 to H'00BFFF
EB6 (8 kbytes)	H'00C000 to H'00DFFF
EB7 (8 kbytes)	H'00E000 to H'00FFFF
EB8 (32 kbytes)	H'010000 to H'017FFF
EB9 (32 kbytes)	H'018000 to H'01FFFF

• H8S/2638, H8S/2639

Block (Size)	Addresses
EB0 (4 kbytes)	H'000000 to H'000FFF
EB1 (4 kbytes)	H'001000 to H'001FFF
EB2 (4 kbytes)	H'002000 to H'002FFF
EB3 (4 kbytes)	H'003000 to H'003FFF
EB4 (4 kbytes)	H'004000 to H'004FFF
EB5 (4 kbytes)	H'005000 to H'005FFF
EB6 (4 kbytes)	H'006000 to H'006FFF
EB7 (4 kbytes)	H'007000 to H'007FFF
EB8 (32 kbytes)	H'008000 to H'00FFFF
EB9 (64 kbytes)	H'010000 to H'01FFFF
EB10 (64 kbytes)	H'020000 to H'02FFFF
EB11 (64 kbytes)	H'030000 to H'03FFFF

• H8S/2635

Block (Size)	Addresses
EB0 (4 kbytes)	H'000000 to H'000FFF
EB1 (4 kbytes)	H'001000 to H'001FFF
EB2 (4 kbytes)	H'002000 to H'002FFF
EB3 (4 kbytes)	H'003000 to H'003FFF
EB4 (4 kbytes)	H'004000 to H'004FFF
EB5 (4 kbytes)	H'005000 to H'005FFF
EB6 (4 kbytes)	H'006000 to H'006FFF
EB7 (4 kbytes)	H'007000 to H'007FFF
EB8 (32 kbytes)	H'008000 to H'00FFFF
EB9 (64 kbytes)	H'010000 to H'01FFFF
EB10 (64 kbytes)	H'020000 to H'02FFFF

• H8S/2630

Block (Size)	Addresses
EB0 (4 kbytes)	H'000000 to H'000FFF
EB1 (4 kbytes)	H'001000 to H'001FFF
EB2 (4 kbytes)	H'002000 to H'002FFF
EB3 (4 kbytes)	H'003000 to H'003FFF
EB4 (4 kbytes)	H'004000 to H'004FFF
EB5 (4 kbytes)	H'005000 to H'005FFF
EB6 (4 kbytes)	H'006000 to H'006FFF
EB7 (4 kbytes)	H'007000 to H'007FFF
EB8 (32 kbytes)	H'008000 to H'00FFFF
EB9 (64 kbytes)	H'010000 to H'01FFFF
EB10 (64 kbytes)	H'020000 to H'02FFFF
EB11 (64 kbytes)	H'030000 to H'03FFFF
EB12 (64 kbytes)	H'040000 to H'04FFFF
EB13 (64 kbytes)	H'050000 to H'05FFFF

- Notes: 1. On the H8S/2636, these bits are reserved.
 2. Reserved in the H8S/2636 and H8S/2635.
 3. Reserved in the H8S/2638, H8S/2639, and H8S/2635.

FLPWCR—Flash Memory Power Control Register H'FFAC **Flash Memory**

Bit	7	6	5	4	3	2	1	0
	PDWND	—	—	—	—	—	—	—
Initial value	0	0	0	0	0	0	0	0
Read/Write	R/W	R	R	R	R	R	R	R

Power-Down Disable

0	Transition to flash memory power-down mode enabled
1	Transition to flash memory power-down mode disabled

PORT1—Port 1 Register **H'FFB0** **Port**

Bit	7	6	5	4	3	2	1	0
	P17	P16	P15	P14	P13	P12	P11	P10
Initial value	—*	—*	—*	—*	—*	—*	—*	—*
Read/Write	R	R	R	R	R	R	R	R

State of the port 1 pins

Note: * Determined by state of pins P17 to P10.

PORT3—Port 3 Register **H'FFB2** **Port**

Bit	7	6	5	4	3	2	1	0
	—	—	P35	P34	P33	P32	P31	P30
Initial value	Undefined	Undefined	—*	—*	—*	—*	—*	—*
Read/Write	—	—	R	R	R	R	R	R

State of the port 3 pins

Note: * Determined by state of pins P35 to P30.

PORT4—Port 4 Register**H'FFB3****Port**

Bit	7	6	5	4	3	2	1	0
	P47	P46	P45	P44	P43	P42	P41	P40
Initial value	—*	—*	—*	—*	—*	—*	—*	—*
Read/Write	R	R	R	R	R	R	R	R

|
State of the port 4 pins

Note: * Determined by state of pins P47 to P40.

PORT9—Port 9 Register**H'FFB8****Port**

Bit	7	6	5	4	3	2	1	0
	—	—	—	—	P93	P92	P91	P90
Initial value	Undefined	Undefined	Undefined	Undefined	—*	—*	—*	—*
Read/Write	—	—	—	—	R	R	R	R

|
State of the port 9 pins

Note: * Determined by state of pins P93 to P90.

PORTA—Port A Register**H'FFB9****Port**

Bit	7	6	5	4	3	2	1	0
	—	—	—	—	PA3	PA2	PA1	PA0
Initial value	Undefined	Undefined	Undefined	Undefined	—*	—*	—*	—*
Read/Write	—	—	—	—	R	R	R	R

|
State of the port A pins

Note: * Determined by state of pins PA3 to PA0.

PORTB—Port B Register **H'FFBA** **Port**

Bit	7	6	5	4	3	2	1	0
	PB7	PB6	PB5	PB4	PB3	PB2	PB1	PB0
Initial value	—*	—*	—*	—*	—*	—*	—*	—*
Read/Write	R	R	R	R	R	R	R	R

|
State of the port B pins

Note: * Determined by state of pins PB7 to PB0.

PORTC—Port C Register **H'FFBB** **Port**

Bit	7	6	5	4	3	2	1	0
	PC7	PC6	PC5	PC4	PC3	PC2	PC1	PC0
Initial value	—*	—*	—*	—*	—*	—*	—*	—*
Read/Write	R	R	R	R	R	R	R	R

|
State of the port C pins

Note: * Determined by state of pins PC7 to PC0.

PORTD—Port D Register **H'FFBC** **Port**

Bit	7	6	5	4	3	2	1	0
	PD7	PD6	PD5	PD4	PD3	PD2	PD1	PD0
Initial value	—*	—*	—*	—*	—*	—*	—*	—*
Read/Write	R	R	R	R	R	R	R	R

|
State of the port D pins

Note: * Determined by state of pins PD7 to PD0.

PORTE—Port E Register**H'FFBD****Port**

Bit	7	6	5	4	3	2	1	0
	PE7	PE6	PE5	PE4	PE3	PE2	PE1	PE0
Initial value	—*	—*	—*	—*	—*	—*	—*	—*
Read/Write	R	R	R	R	R	R	R	R

|
State of the port E pins

Note: * Determined by state of pins PE7 to PE0.

PORTF—Port F Register**H'FFBE****Port**

Bit	7	6	5	4	3	2	1	0
	PF7	PF6	PF5	PF4	PF3	—	—	PF0
Initial value	—*	—*	—*	—*	—*	Undefined	Undefined	—*
Read/Write	R	R	R	R	R	—	—	R

|
State of the port F pins

Note: * Determined by state of pins PF7 to PF3, PF0.

Appendix C I/O Port Block Diagrams

C.1 Port 1 Block Diagrams

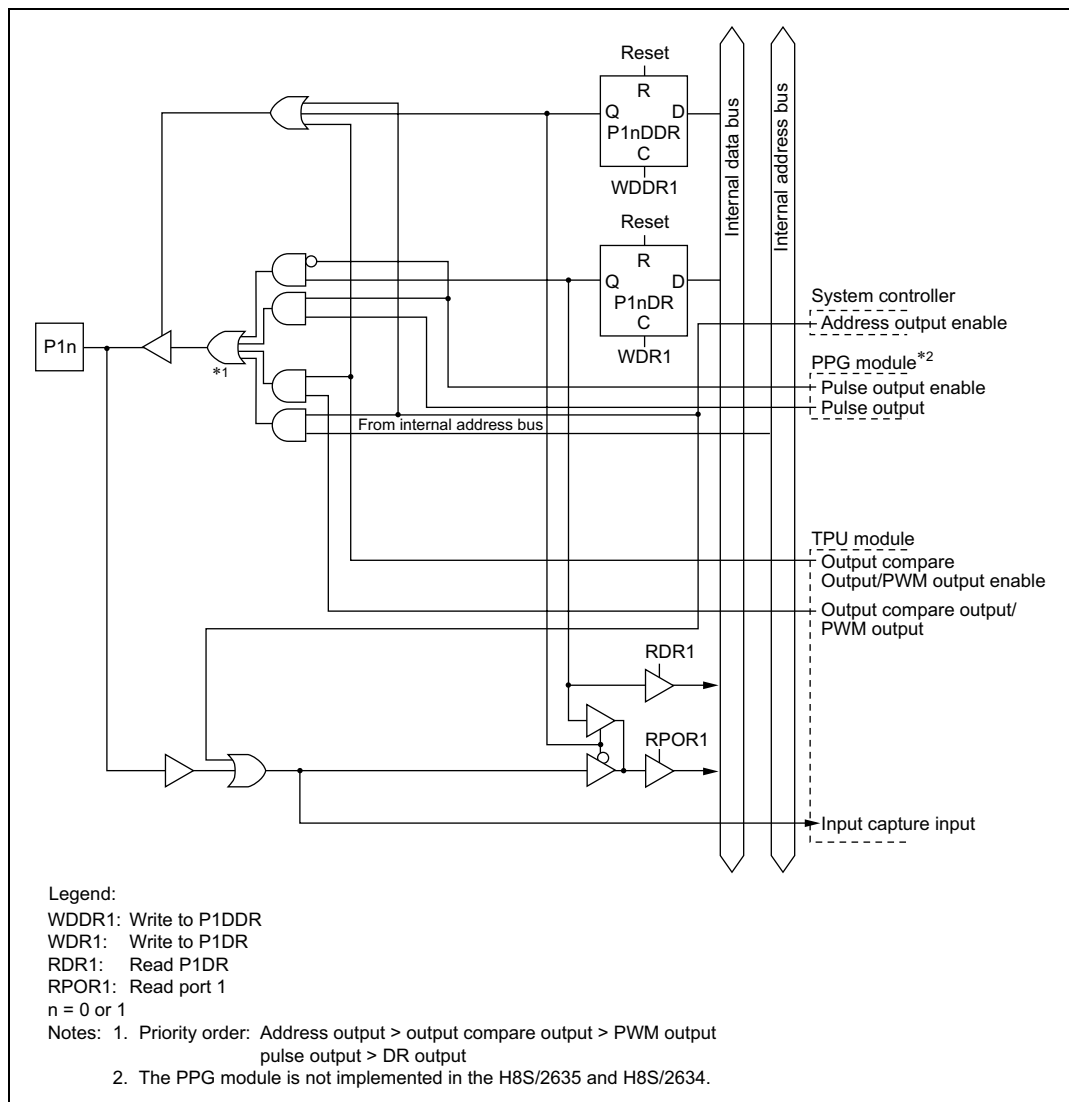

Figure C-1 (a) Port 1 Block Diagram (Pins P10 and P11)

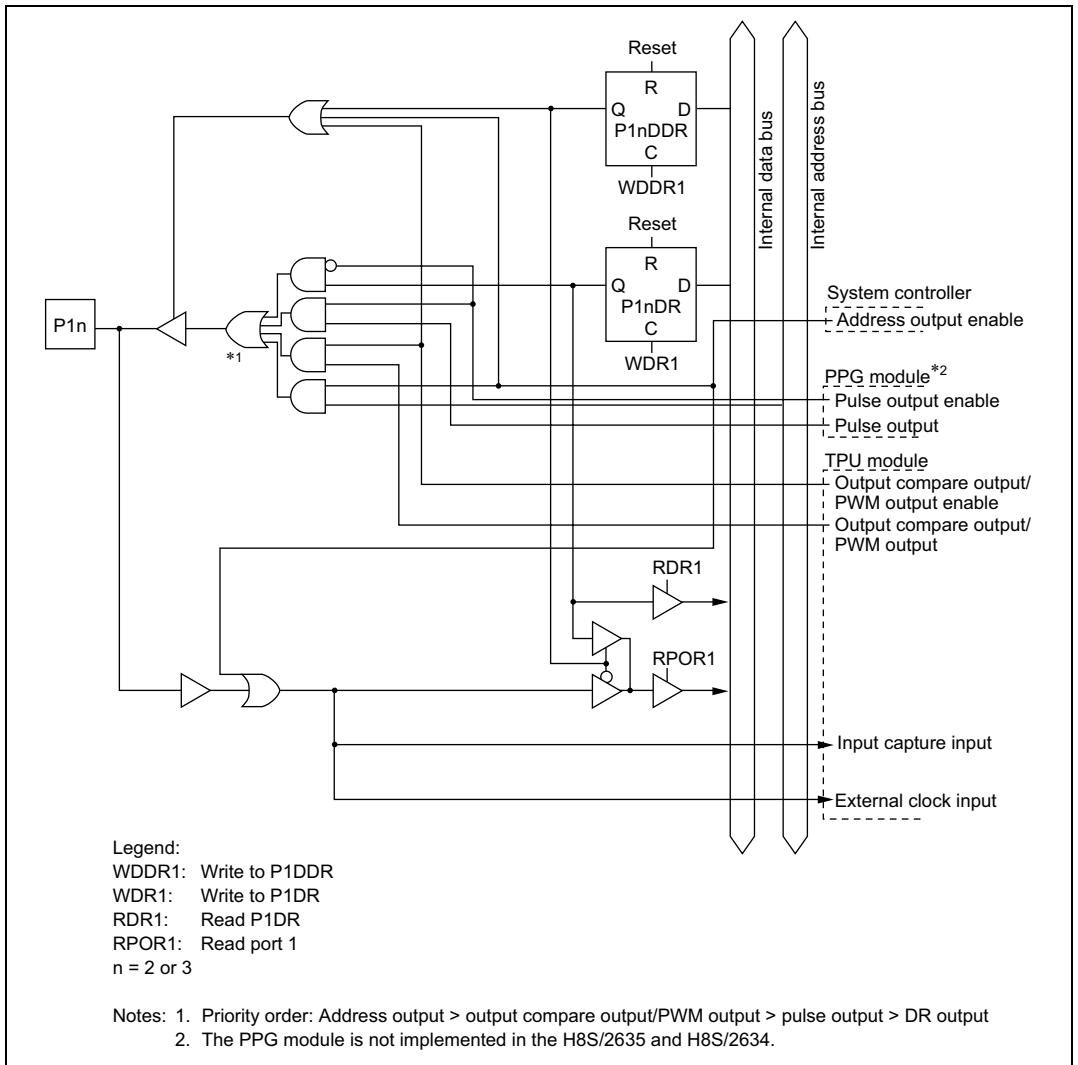

Figure C-1 (b) Port 1 Block Diagram (Pins P12 and P13)

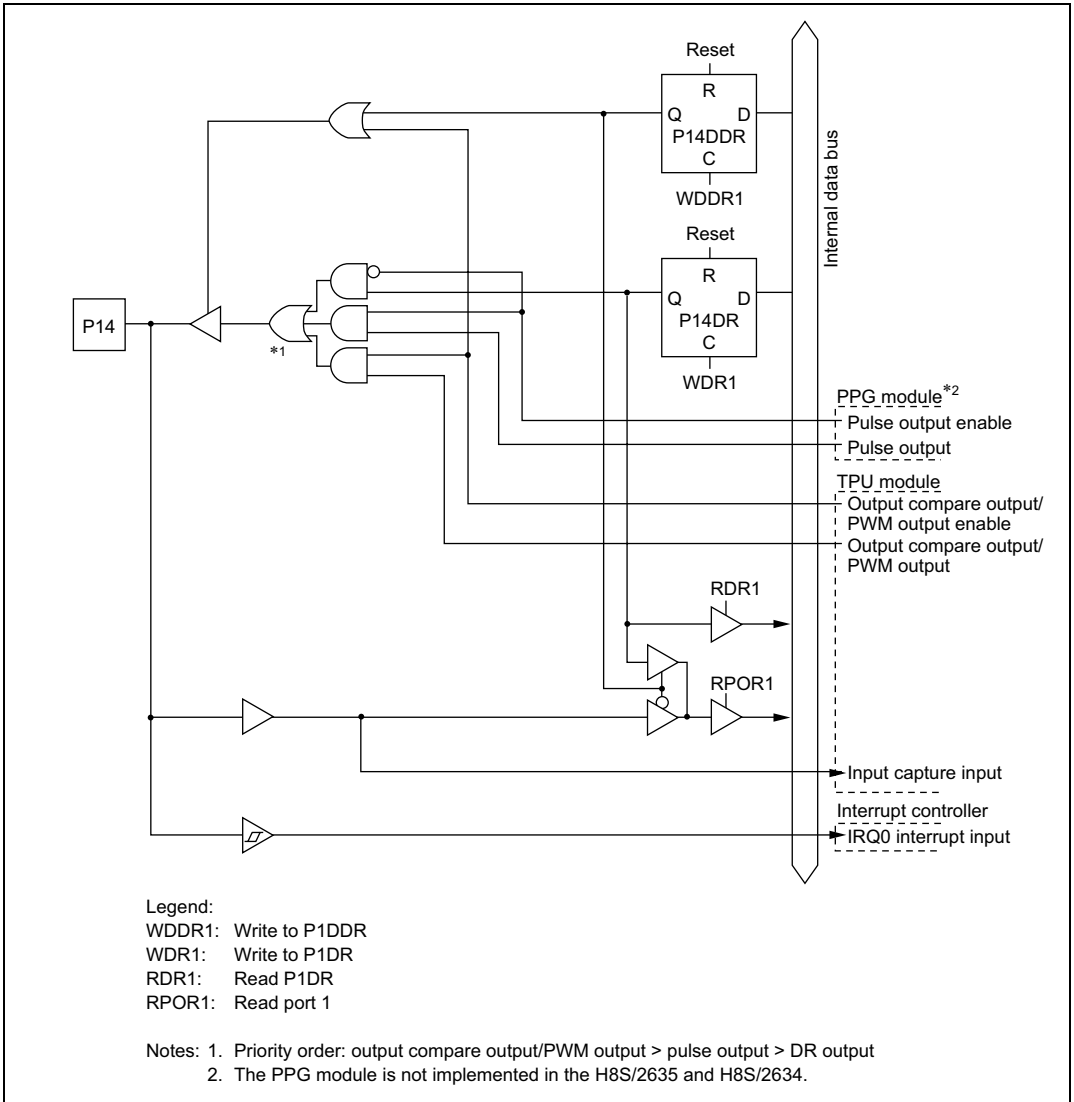

Figure C-1 (c) Port 1 Block Diagram (Pin P14)

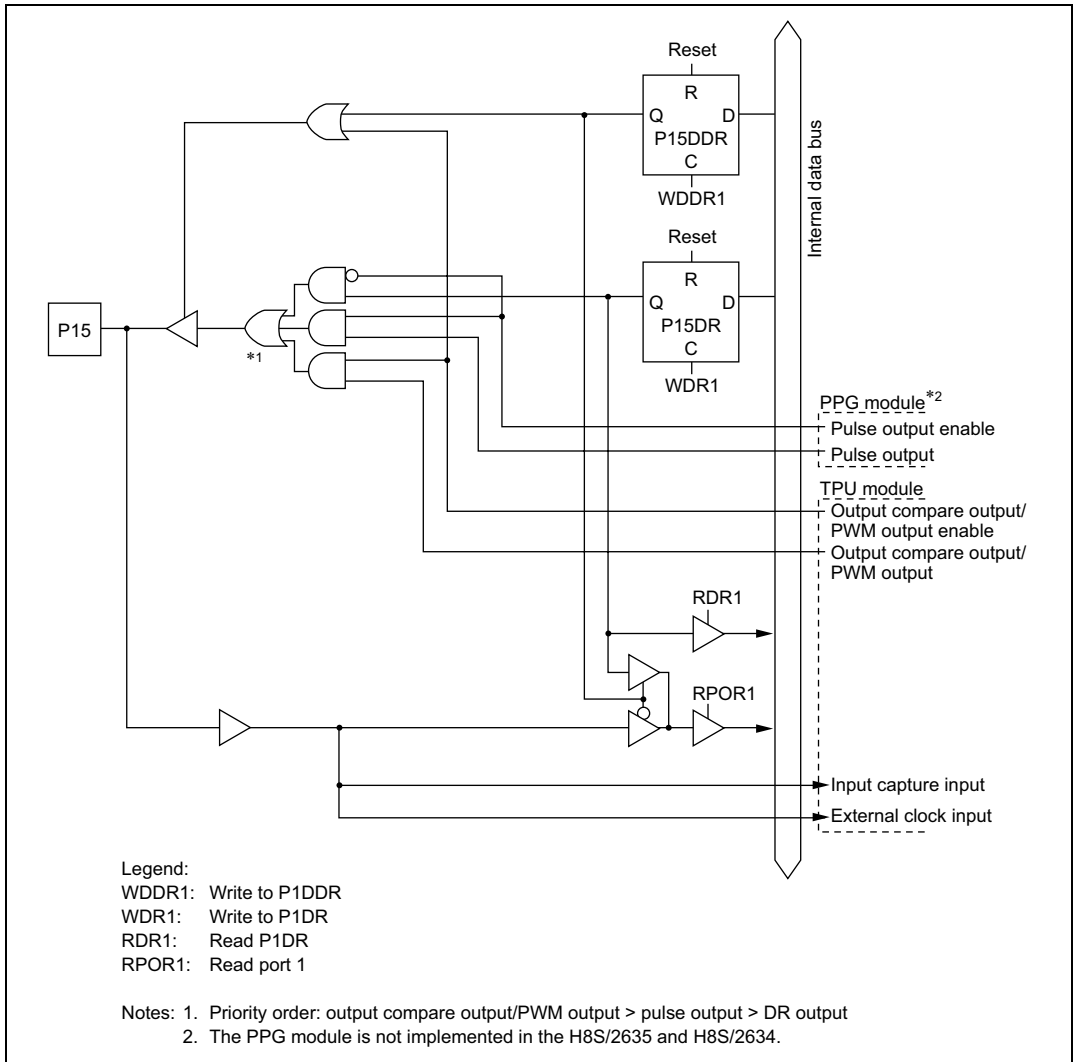

Figure C-1 (d) Port 1 Block Diagram (Pin P15)

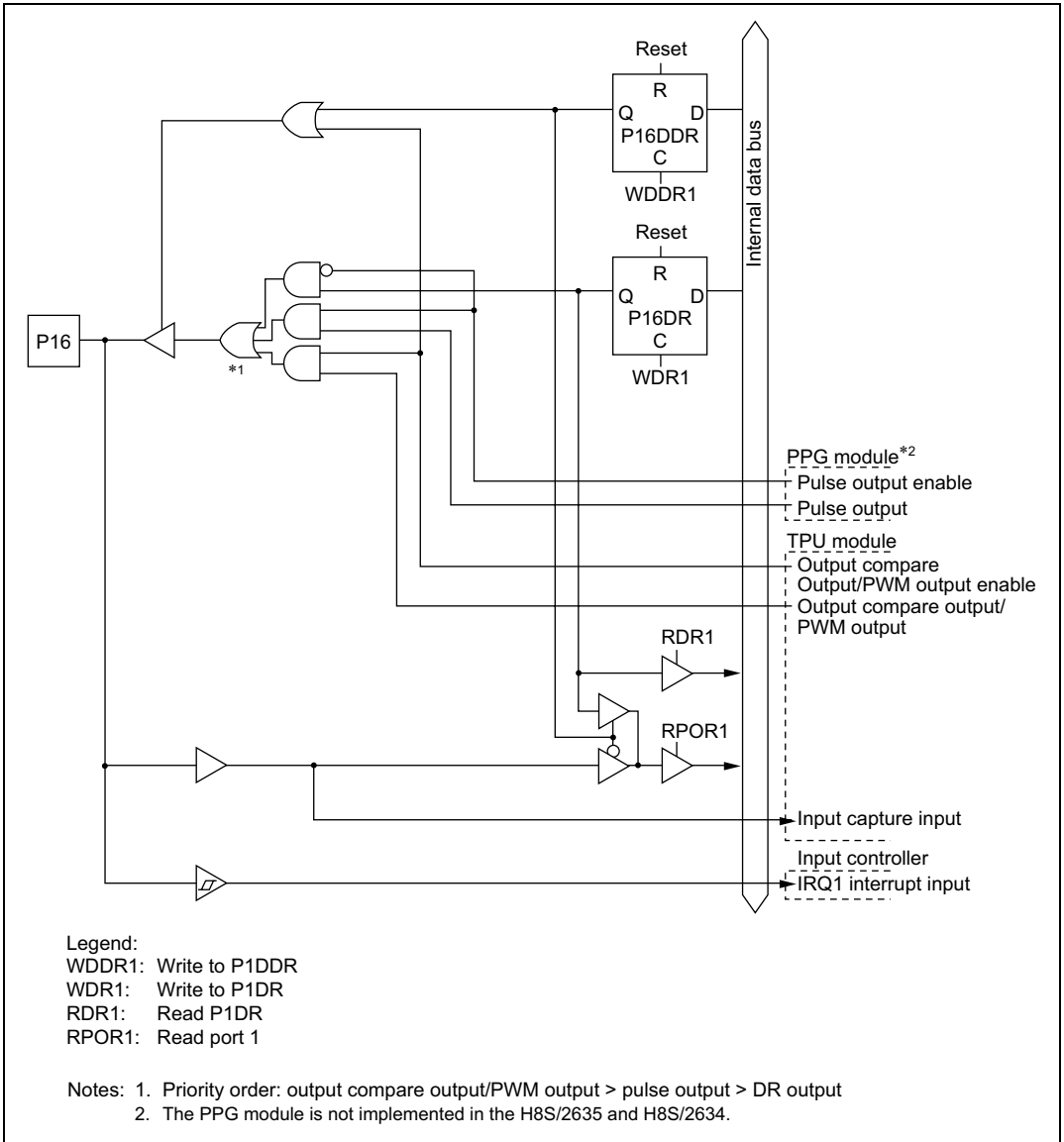

Figure C-1 (e) Port 1 Block Diagram (Pin P16)

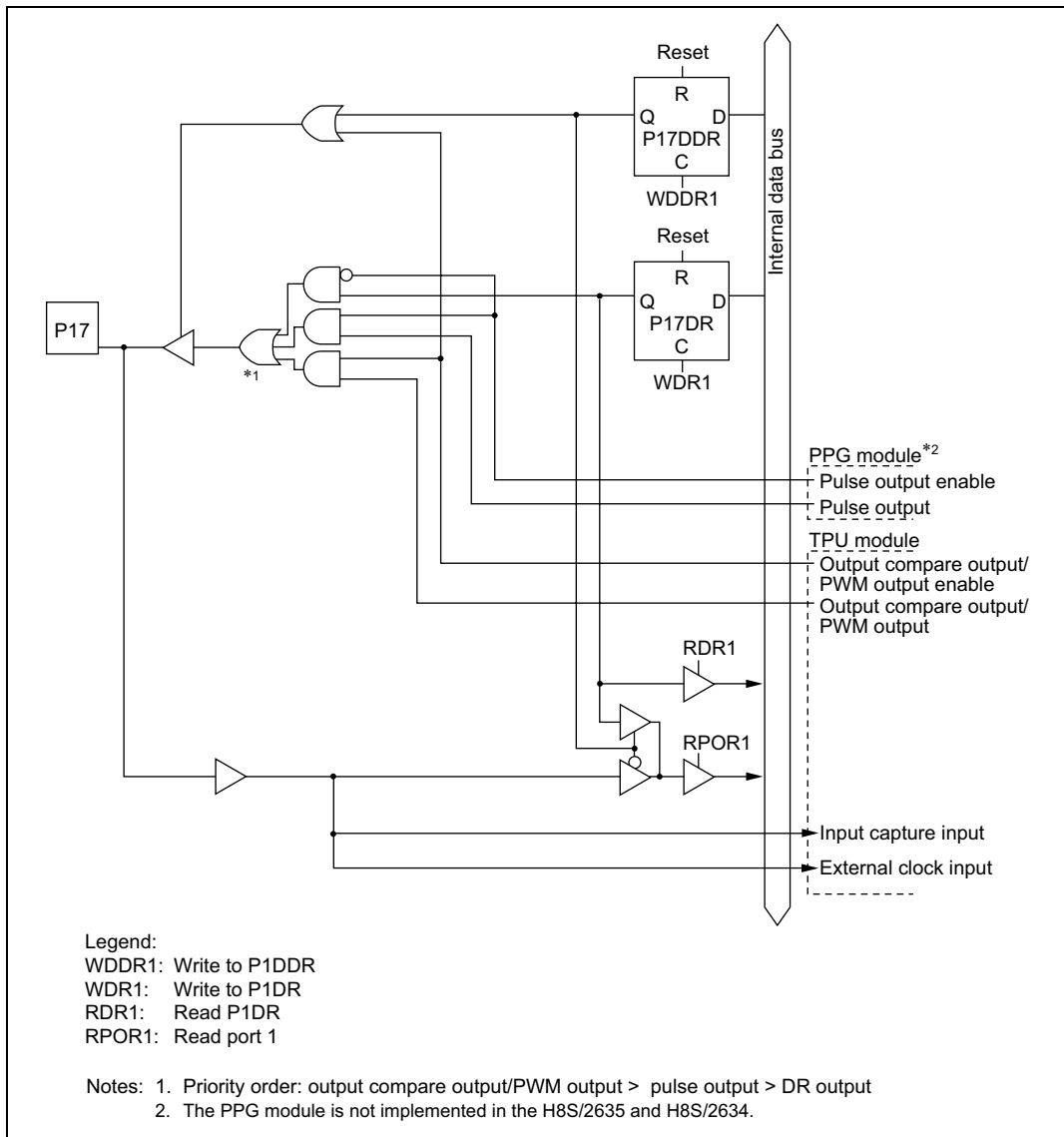

Figure C-1 (f) Port 1 Block Diagram (Pin P17)

C.2 Port 3 Block Diagrams

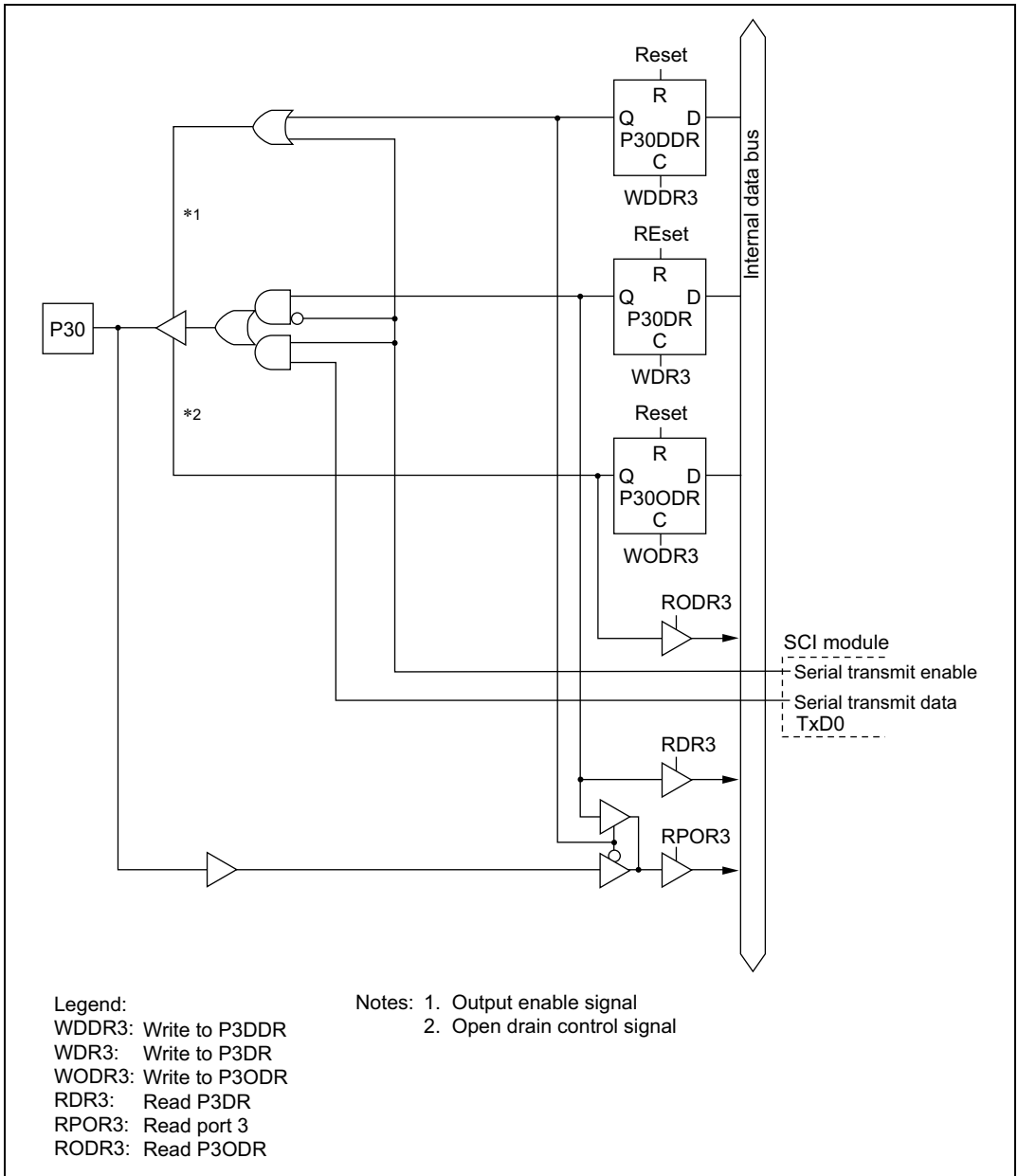

Figure C-2 (a) Port 3 Block Diagram (Pin P30)

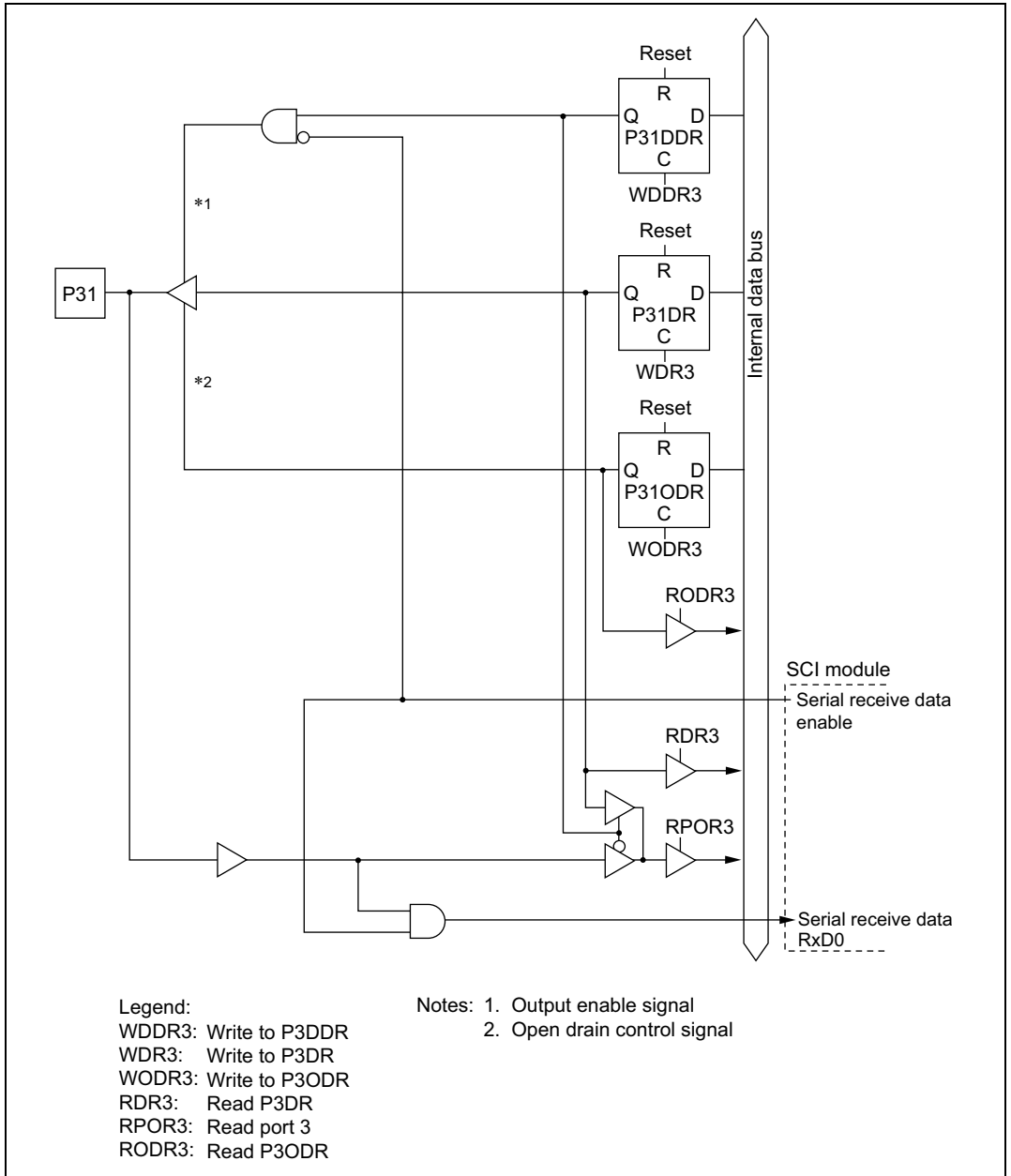

Figure C-2 (b) Port 3 Block Diagram (Pin P31)

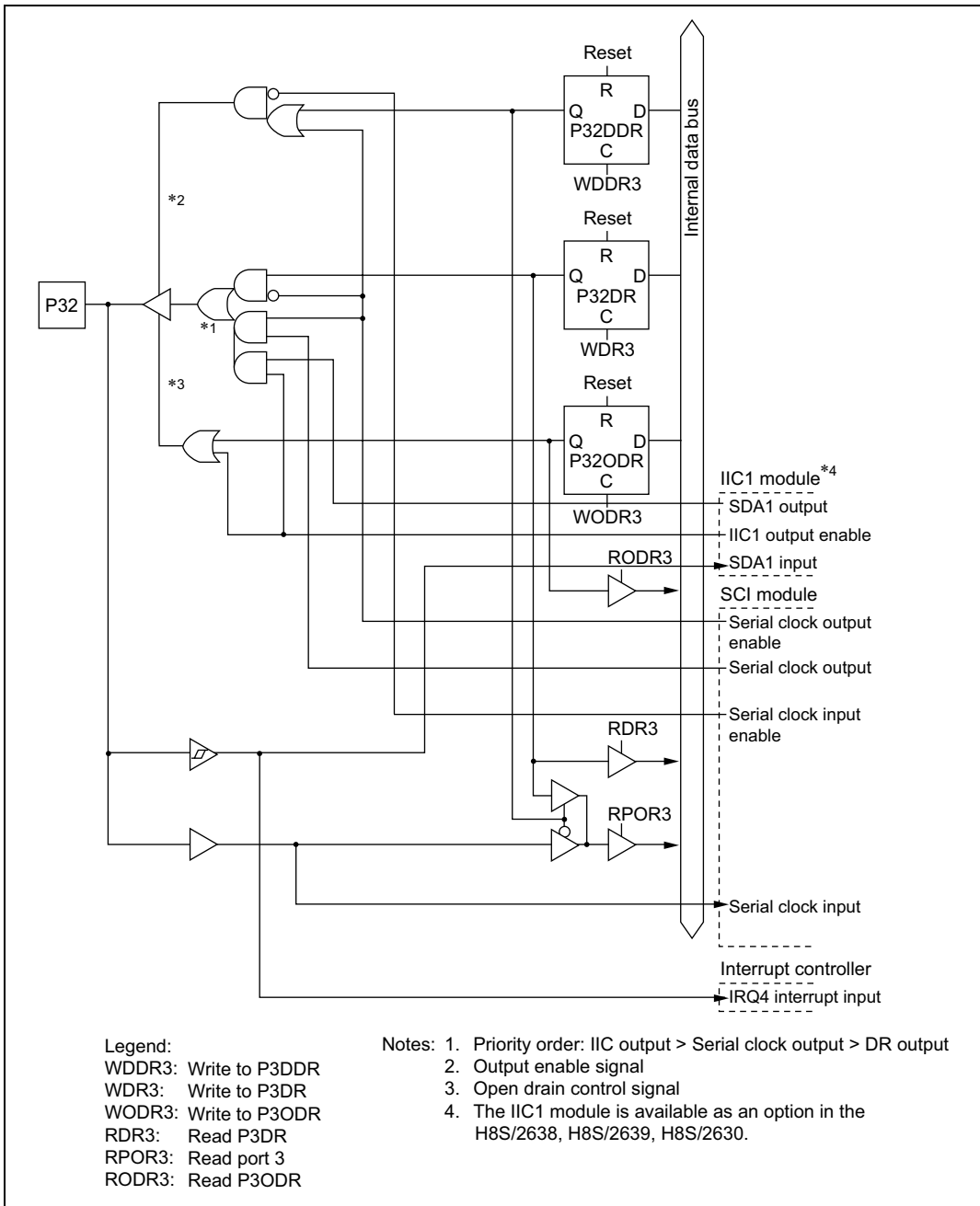

Figure C-2 (c) Port 3 Block Diagram (Pin P32)

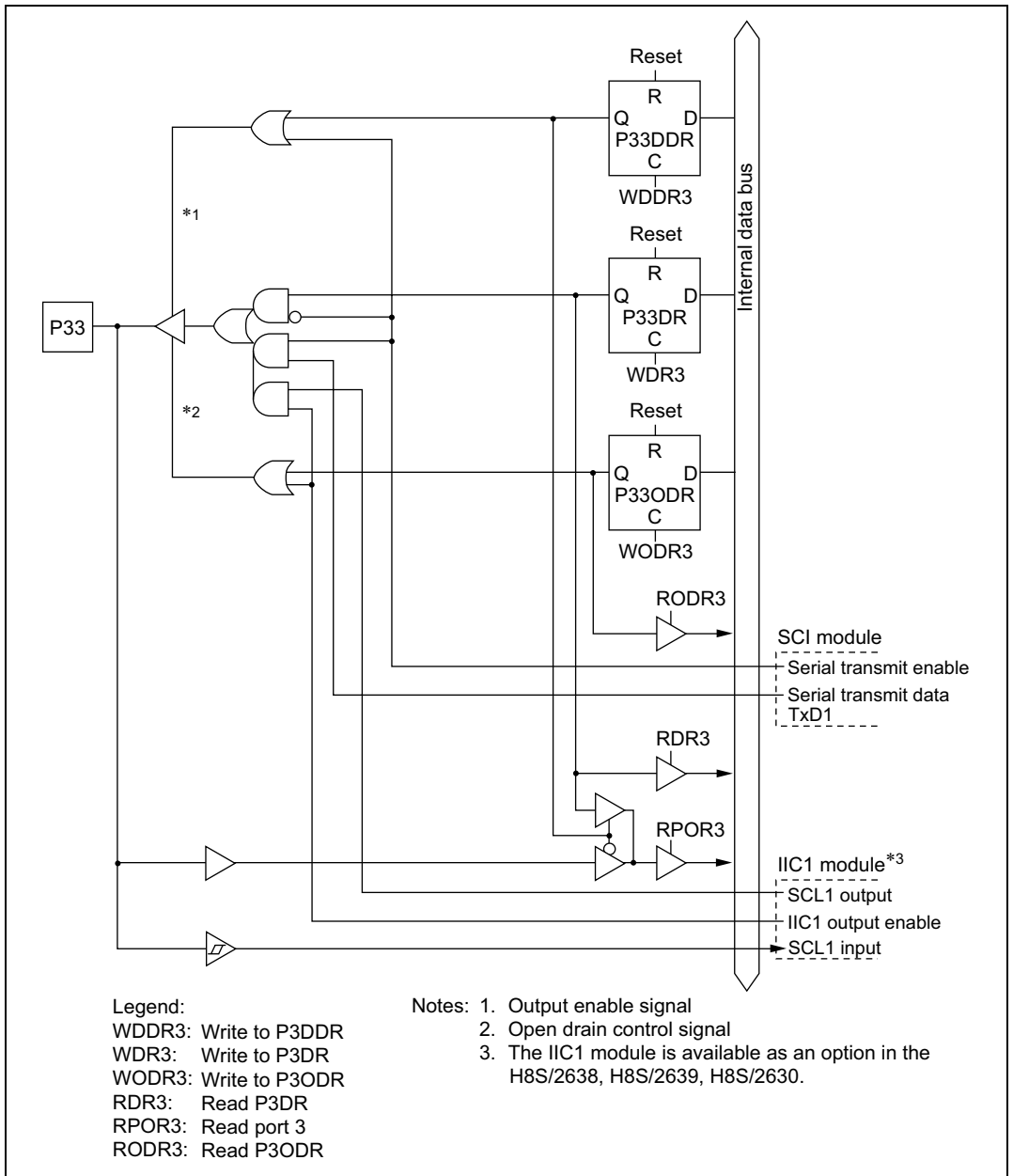

Figure C-2 (d) Port 3 Block Diagram (Pin P33)

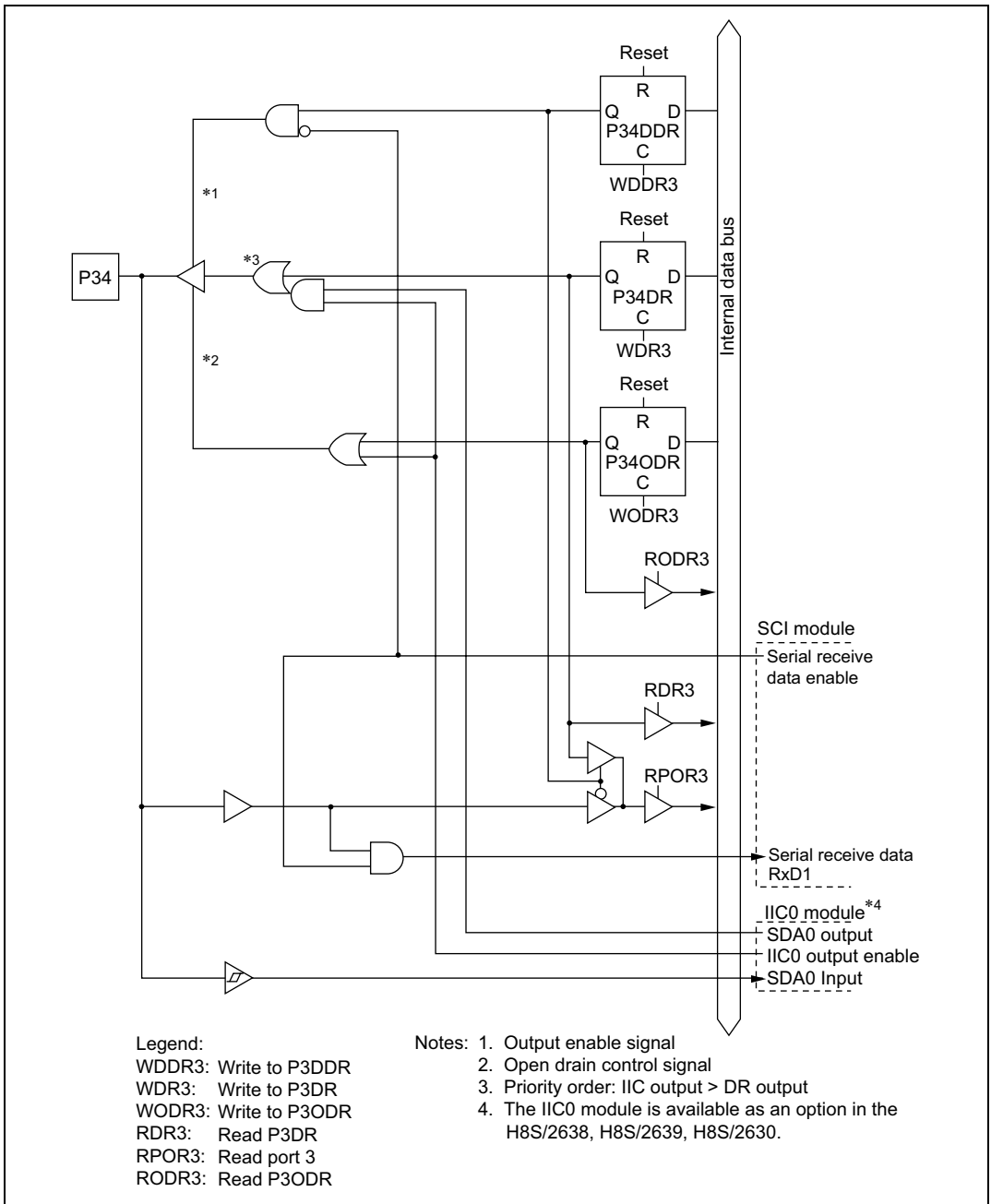

Figure C-2 (e) Port 3 Block Diagram (Pin P34)

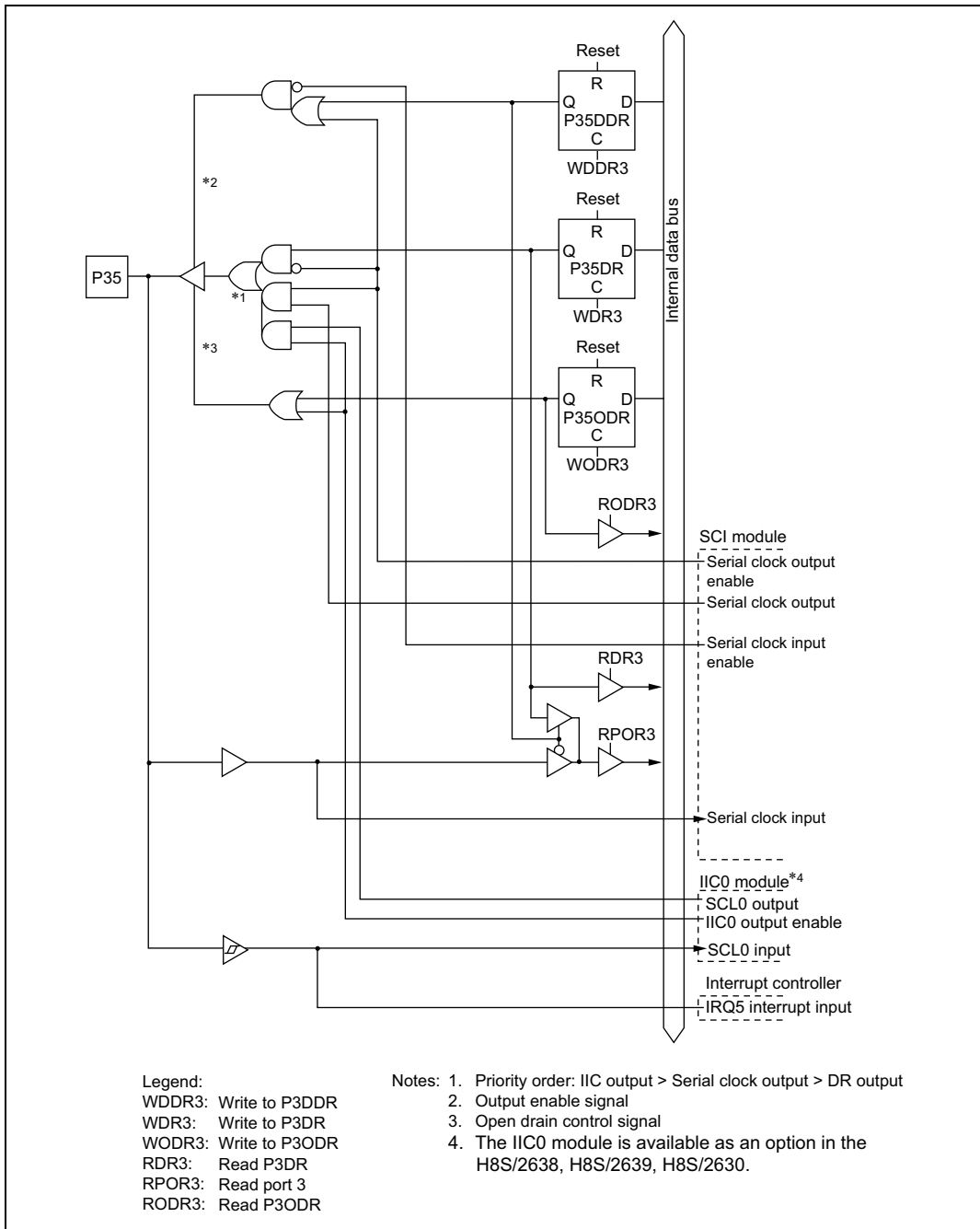

Figure C-2 (f) Port 3 Block Diagram (Pin P35)

C.3 Port 4 Block Diagram

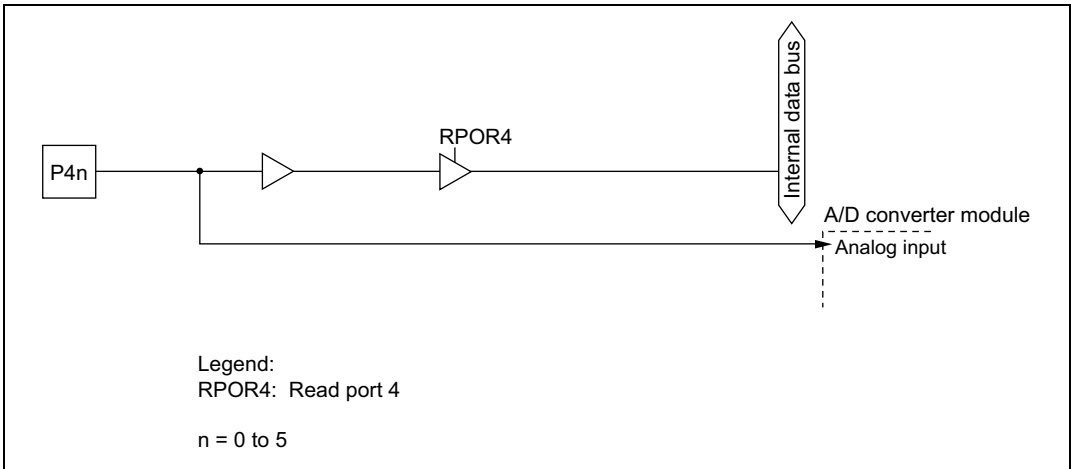

Figure C-3 (a) Port 4 Block Diagram (Pins P40 to P45)

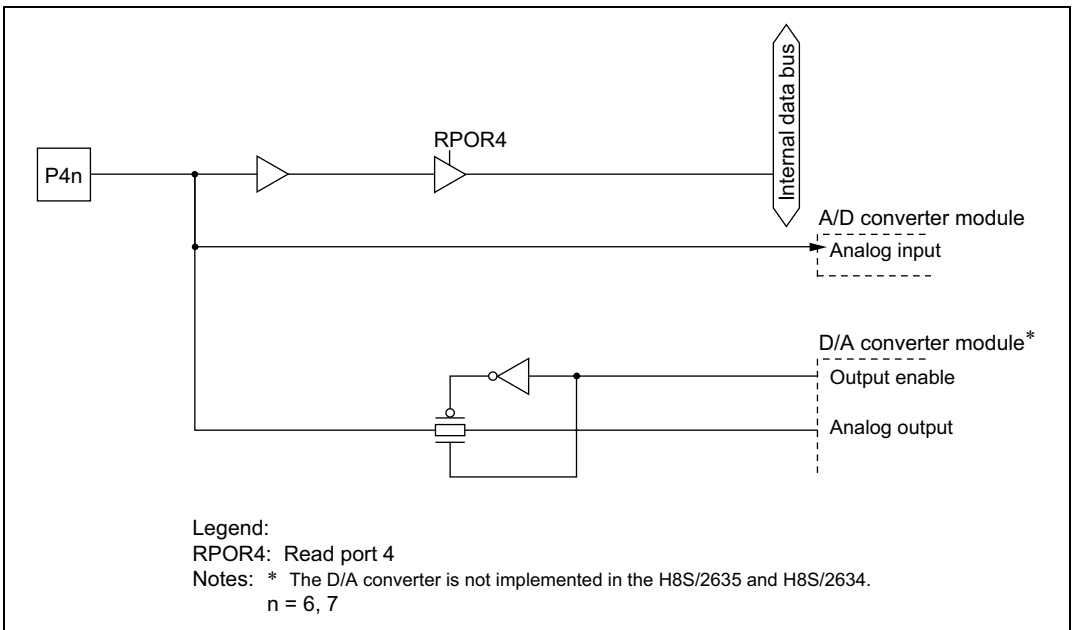

Figure C-3 (b) Port 4 Block Diagram (Pins P46, P47)

C.4 Port 9 Block Diagram

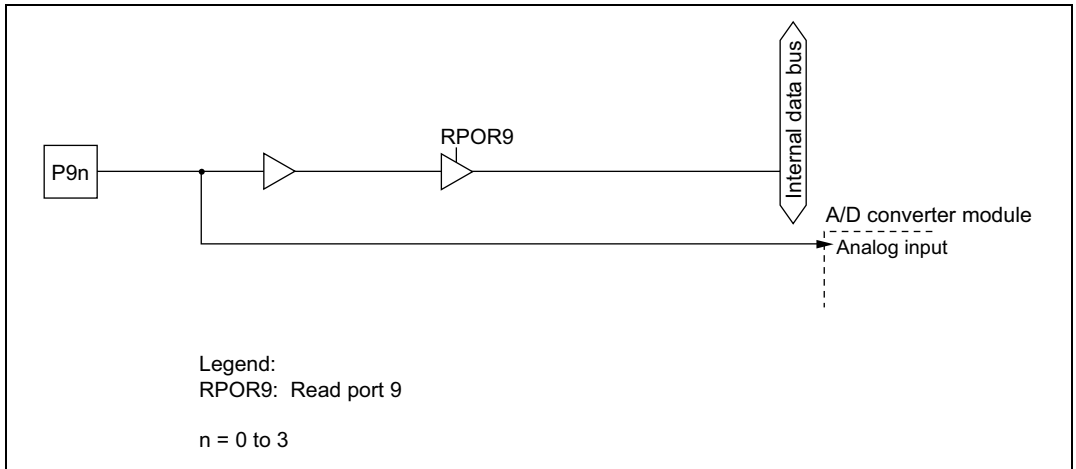

Figure C-4 Port 9 Block Diagram (Pins P90 to P93)

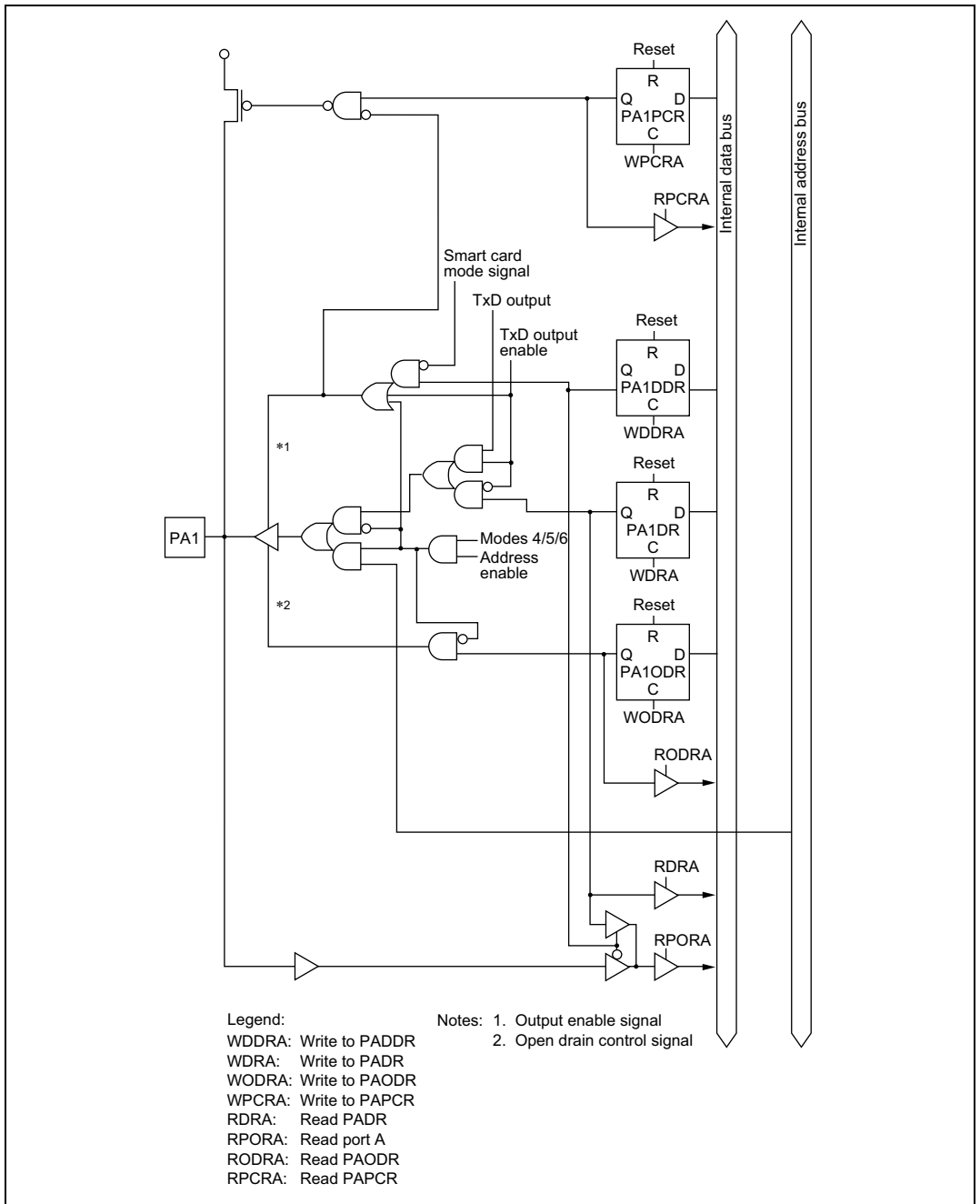

Figure C-5 (b) Port A Block Diagram (Pin PA1)

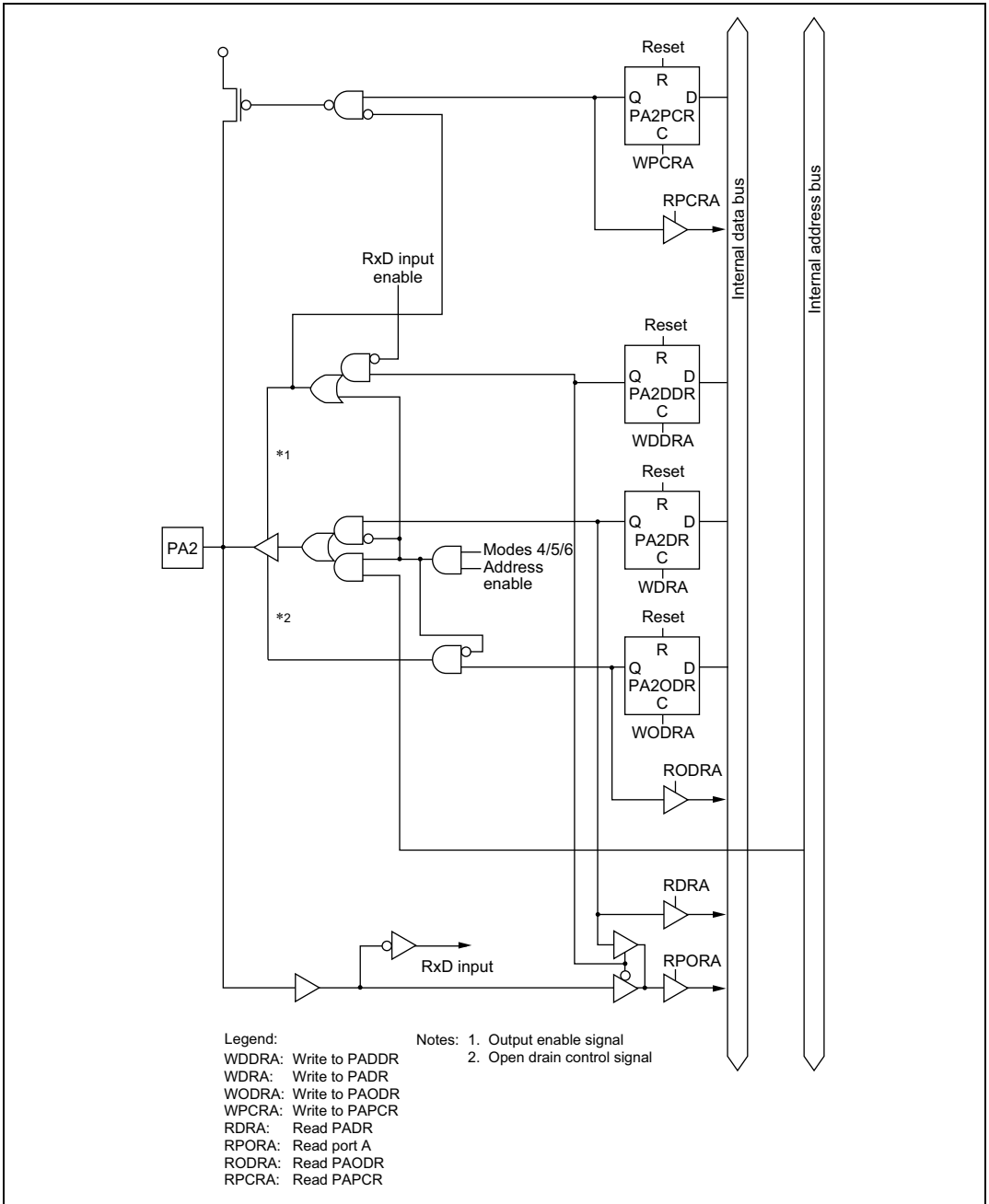

Figure C-5 (c) Port A Block Diagram (Pin PA2)

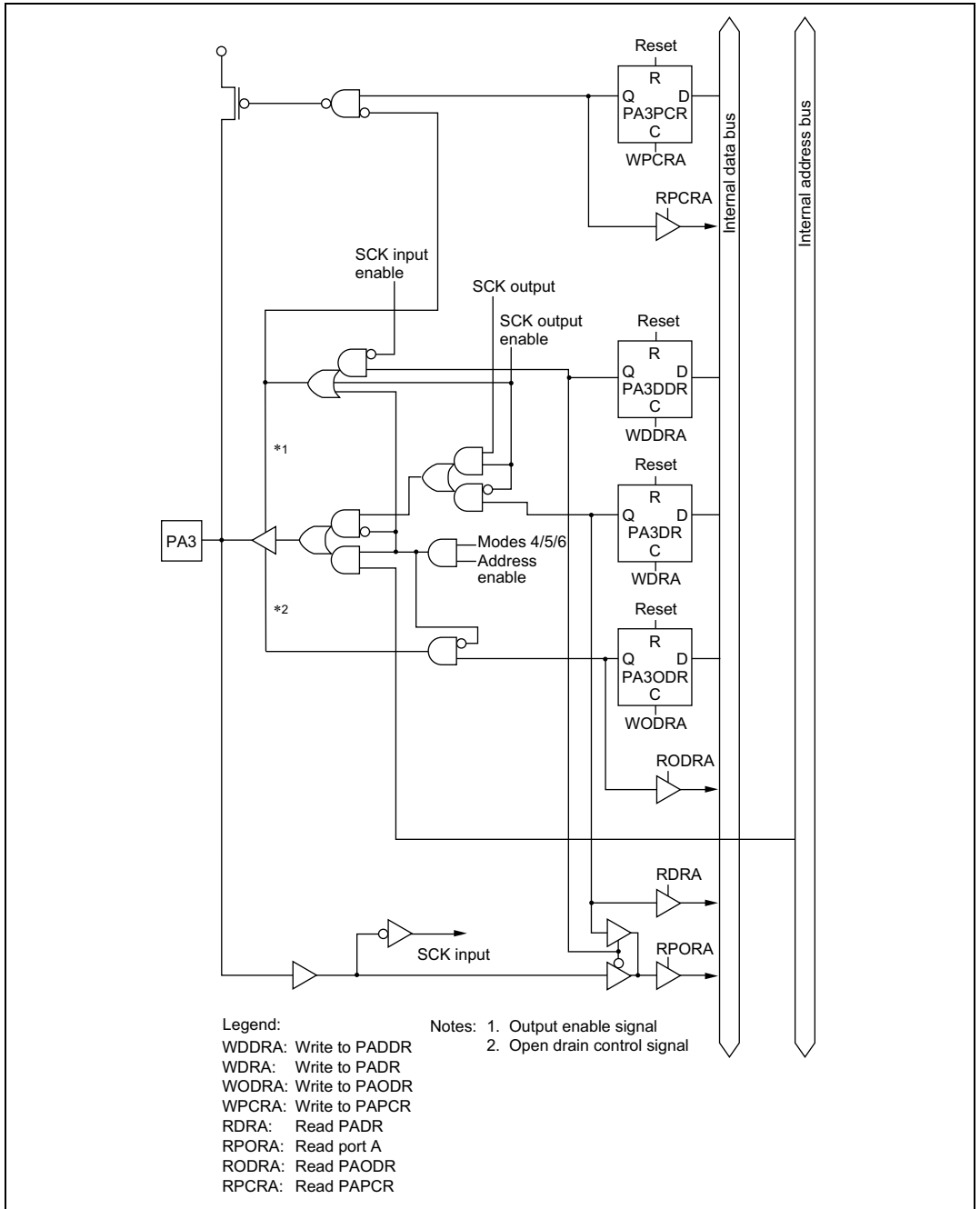

Figure C-5 (d) Port A Block Diagram (Pin PA3)

C.6 Port B Block Diagram

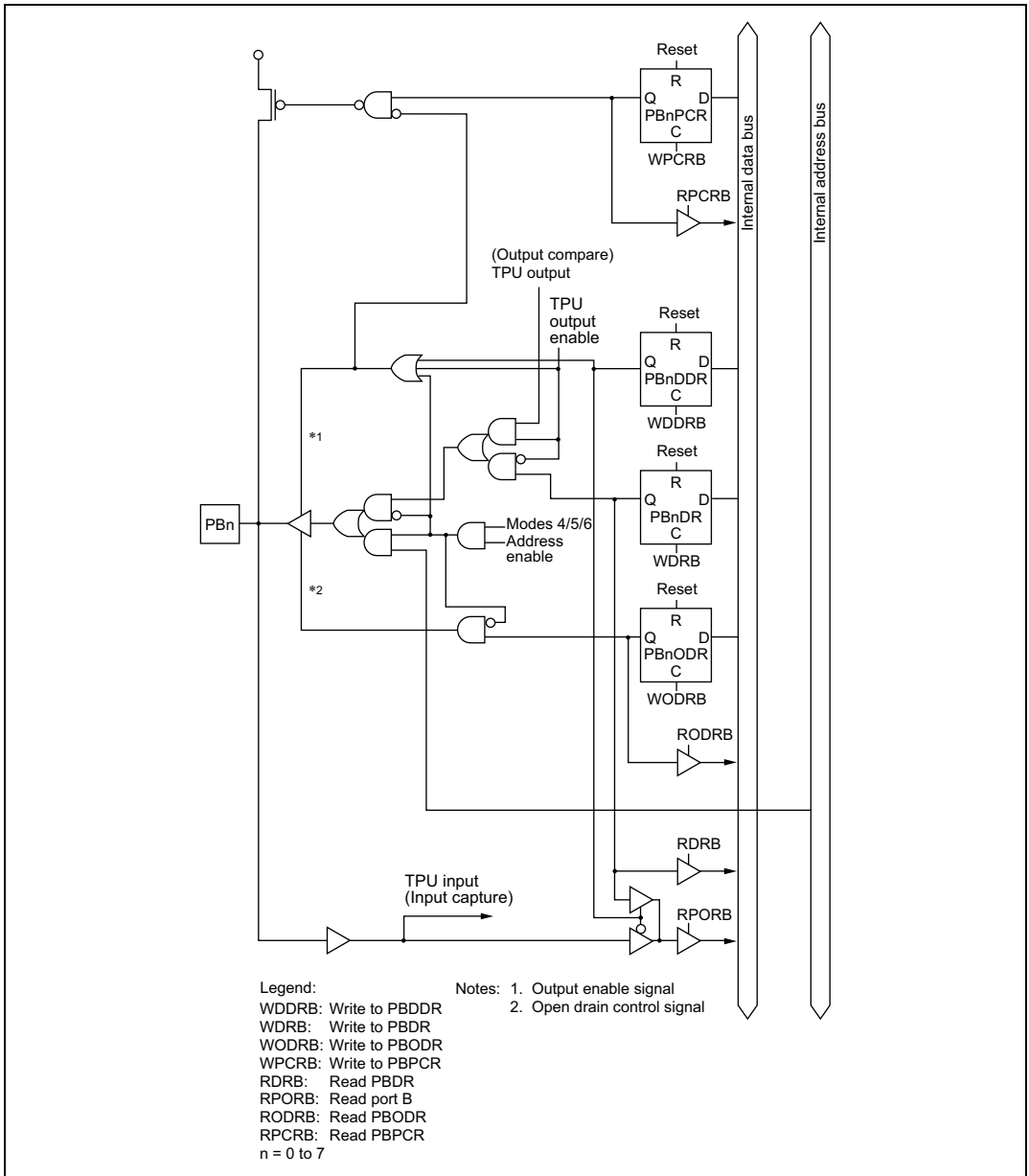

Figure C-6 Port B Block Diagram (Pins PB0 to PB7)

C.7 Port C Block Diagram

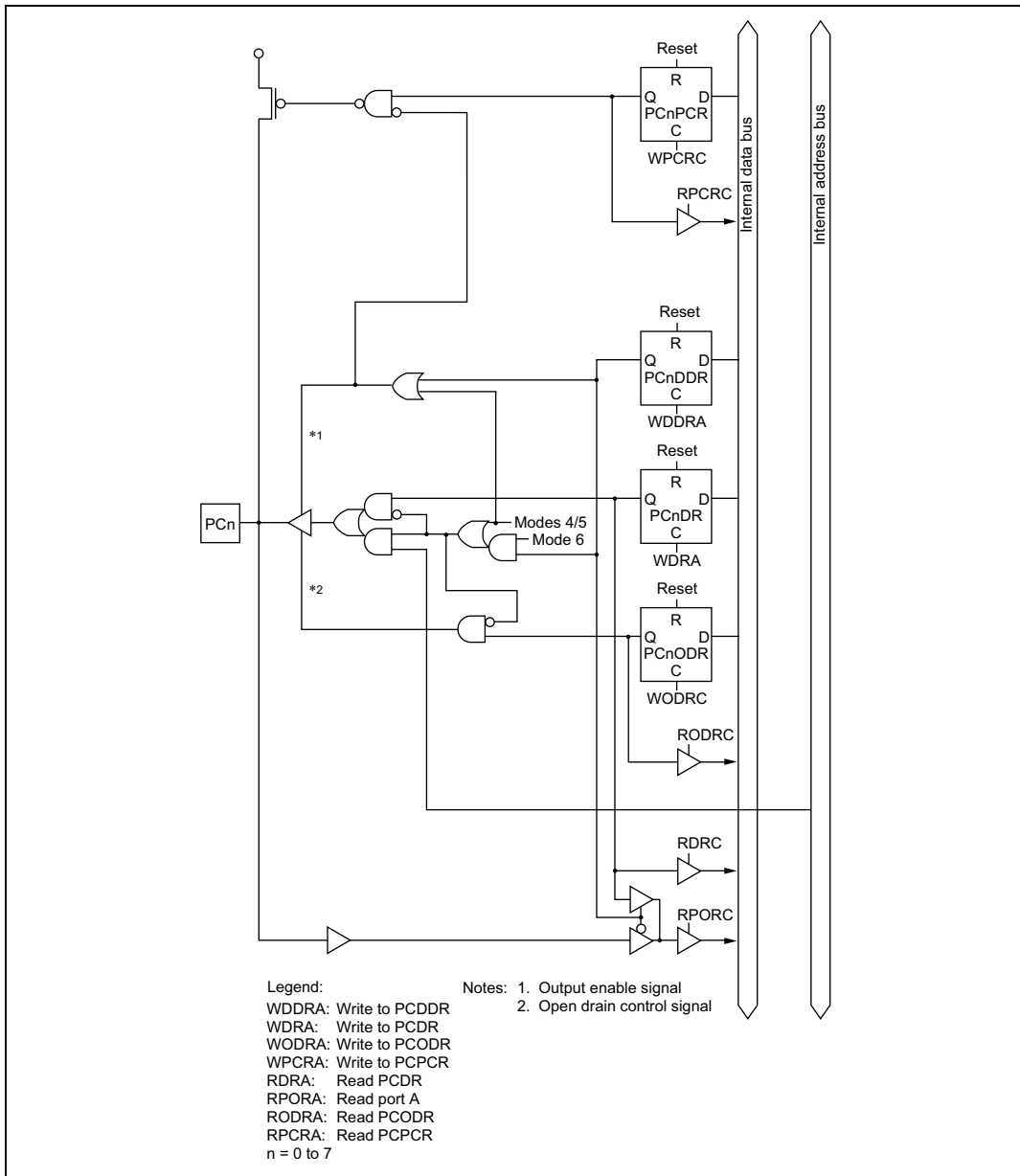

Figure C-7 Port C Block Diagram (Pins PC0 to PC7)

C.8 Port D Block Diagram

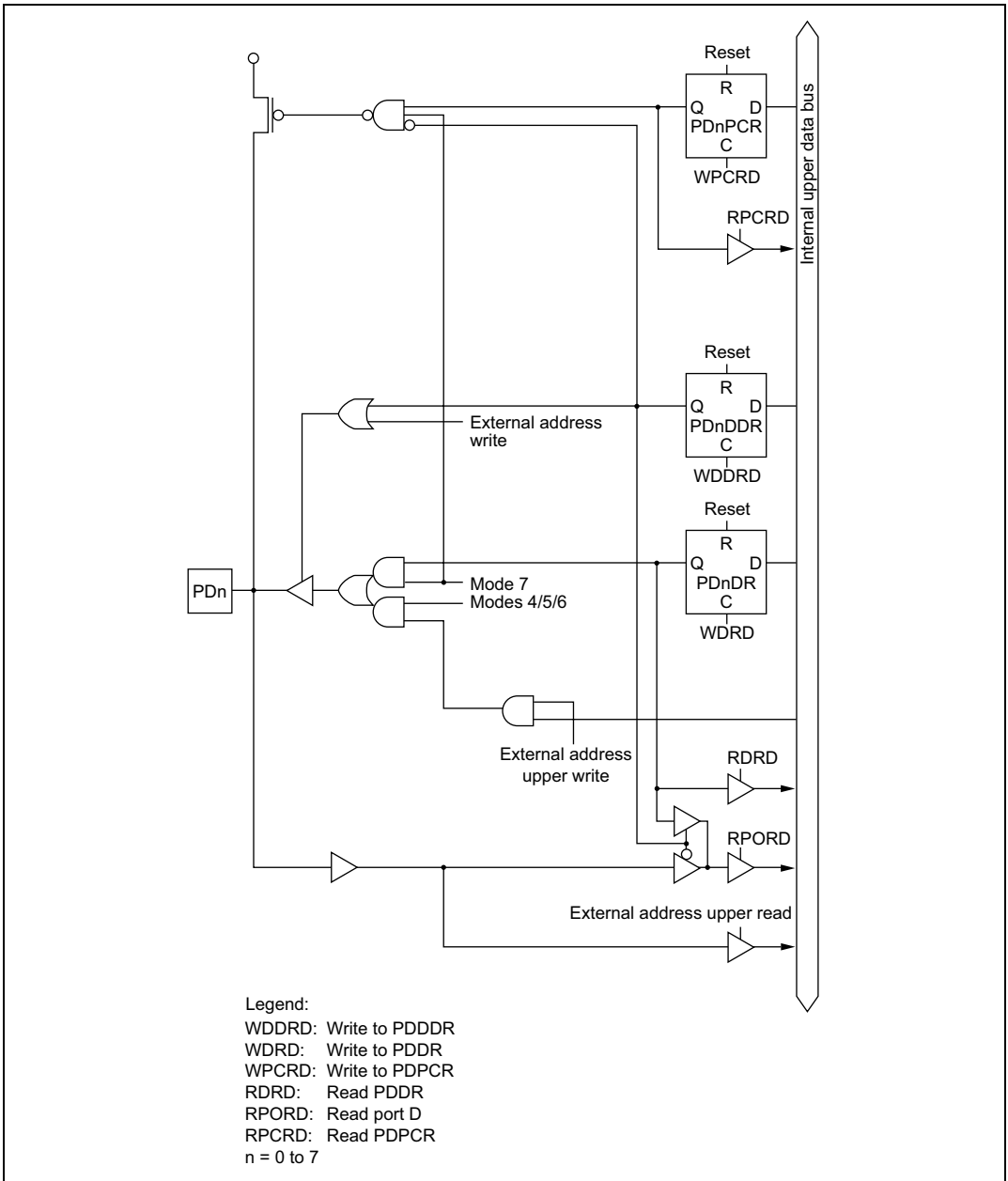

Figure C-8 Port D Block Diagram (Pins PD0 to PD7)

C.9 Port E Block Diagram

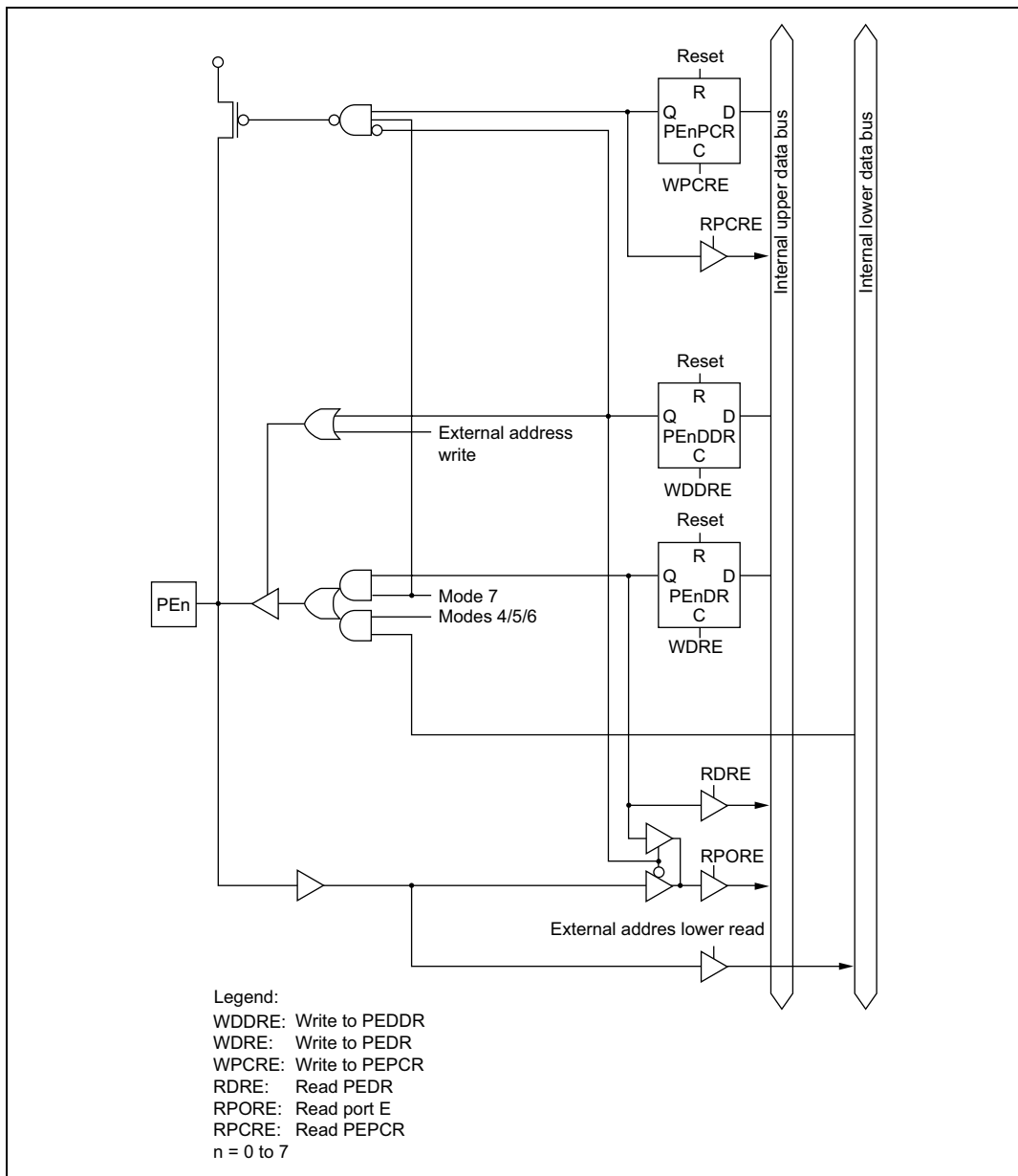

Figure C-9 Port E Block Diagram (Pins PE0 to PE7)

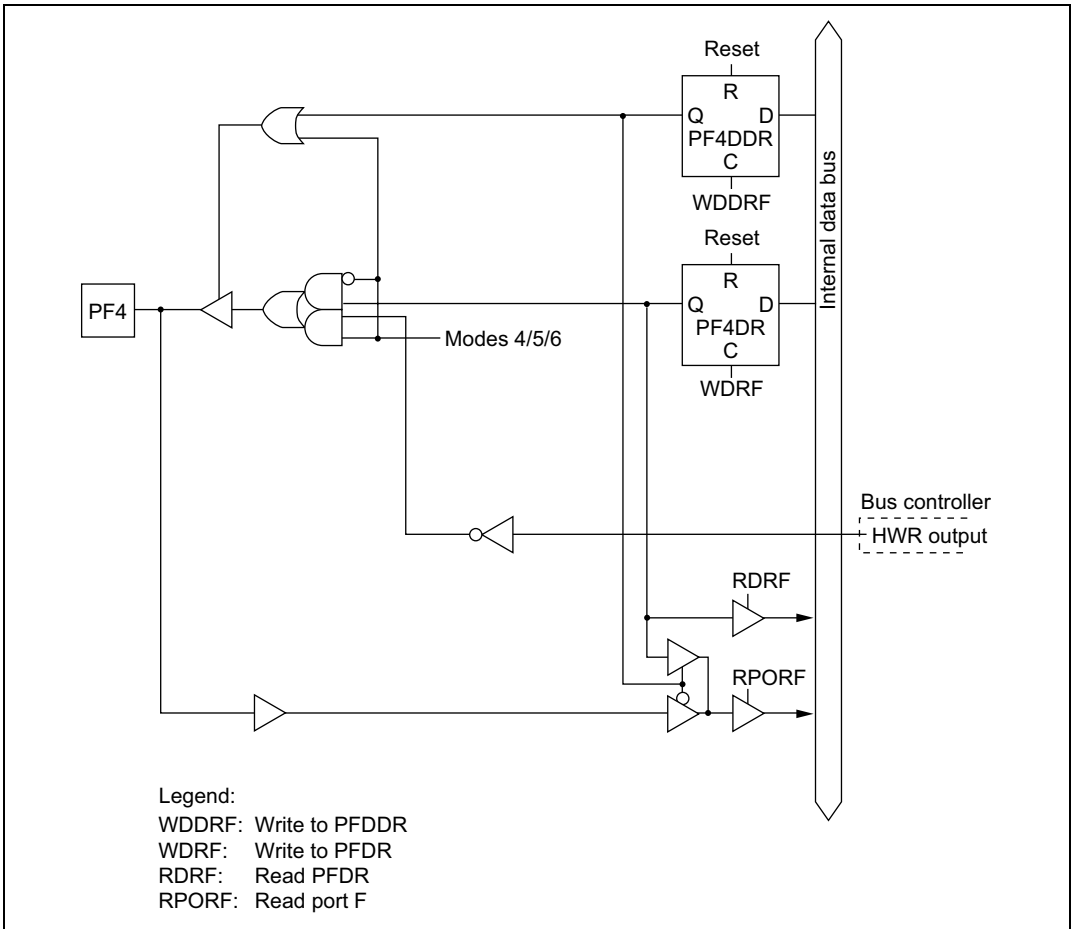

Figure C-10 (c) Port F Block Diagram (Pin PF4)

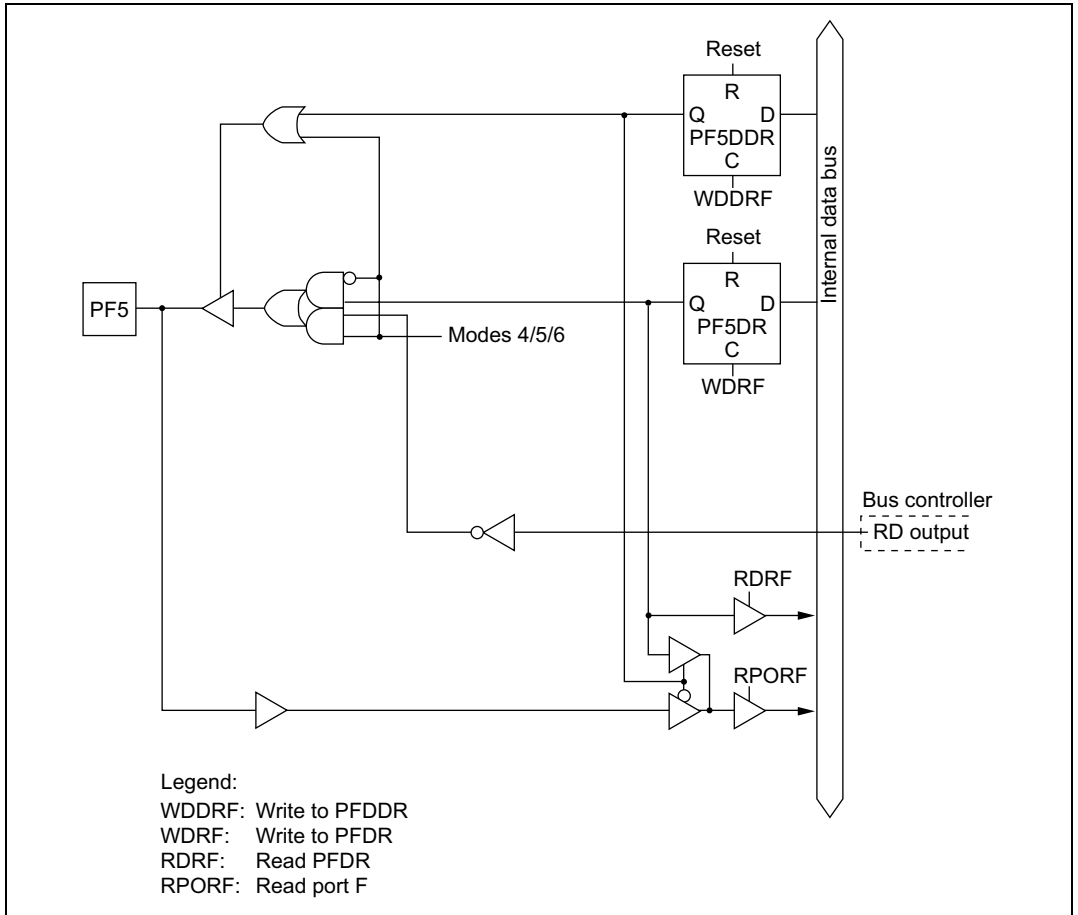

Figure C-10 (d) Port F Block Diagram (Pin PF5)

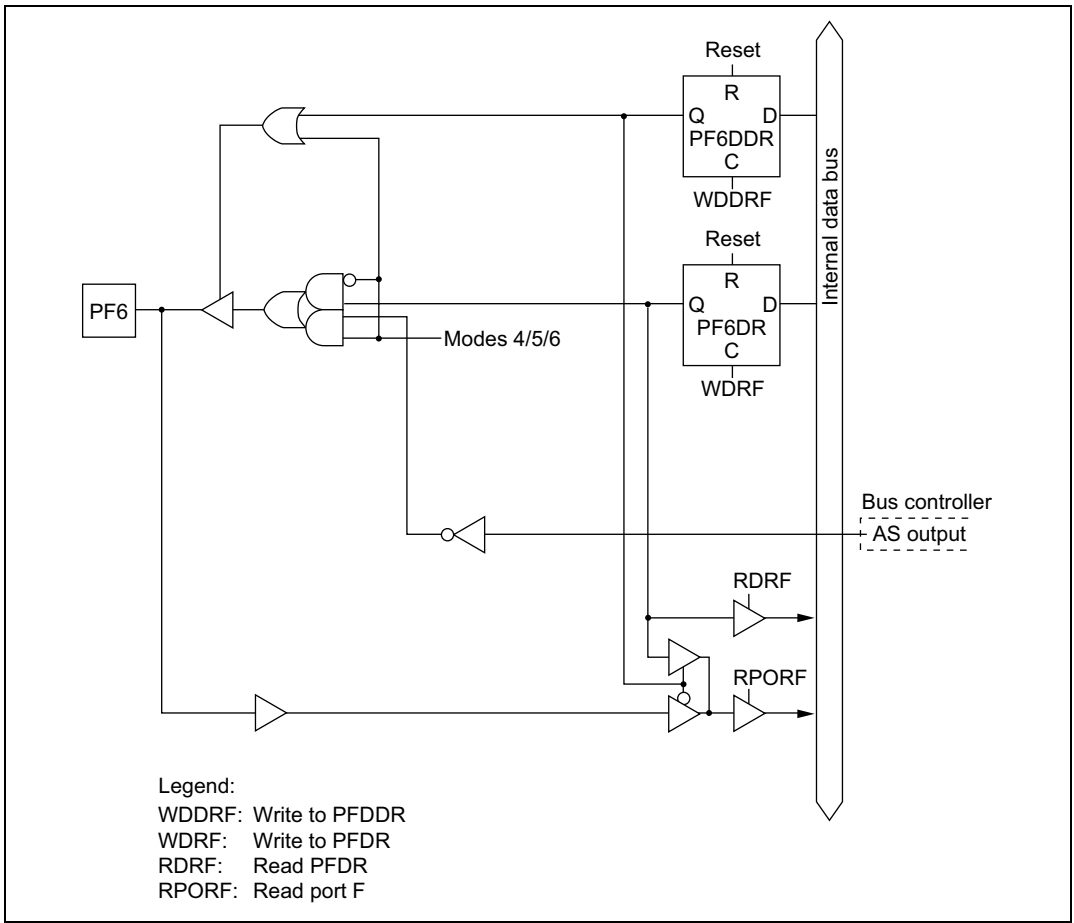

Figure C-10 (e) Port F Block Diagram (Pin PF6)

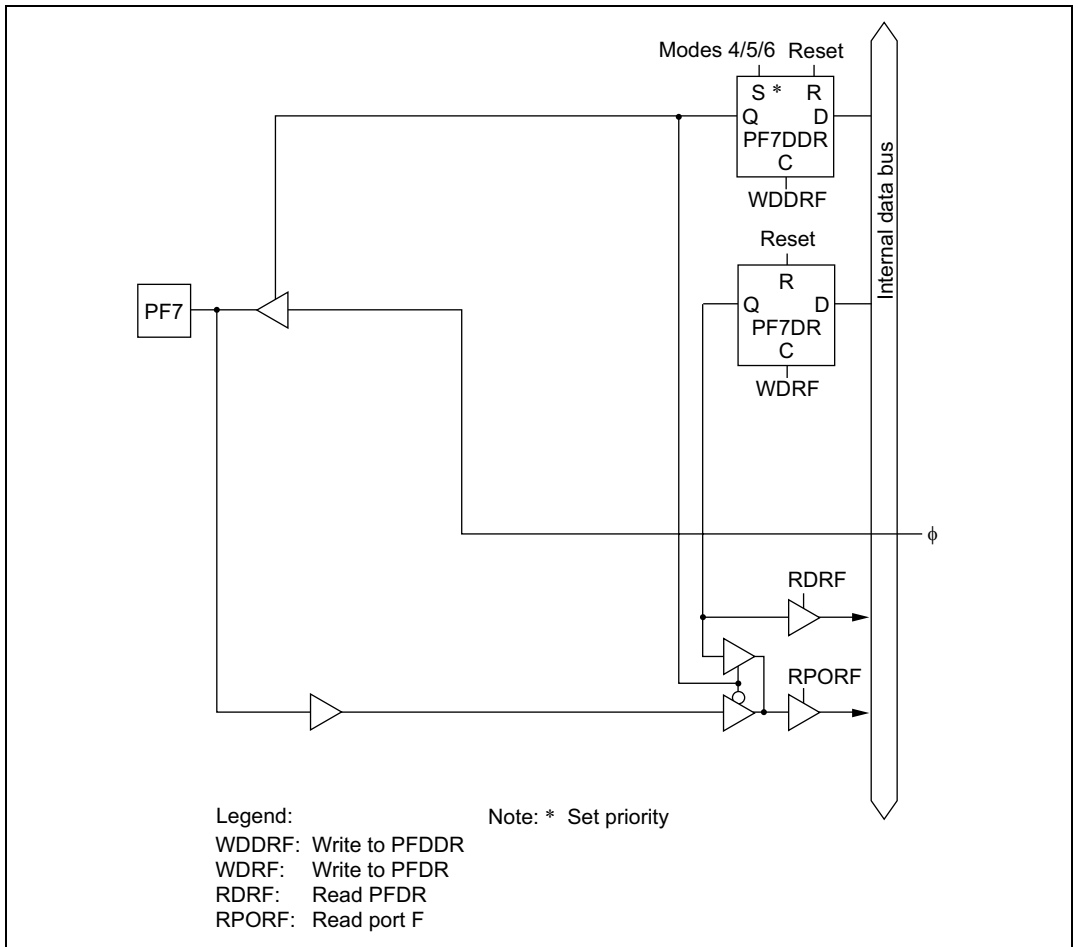

Figure C-10 (f) Port F Block Diagram (Pin PF7)

C.11 Port H Block Diagram

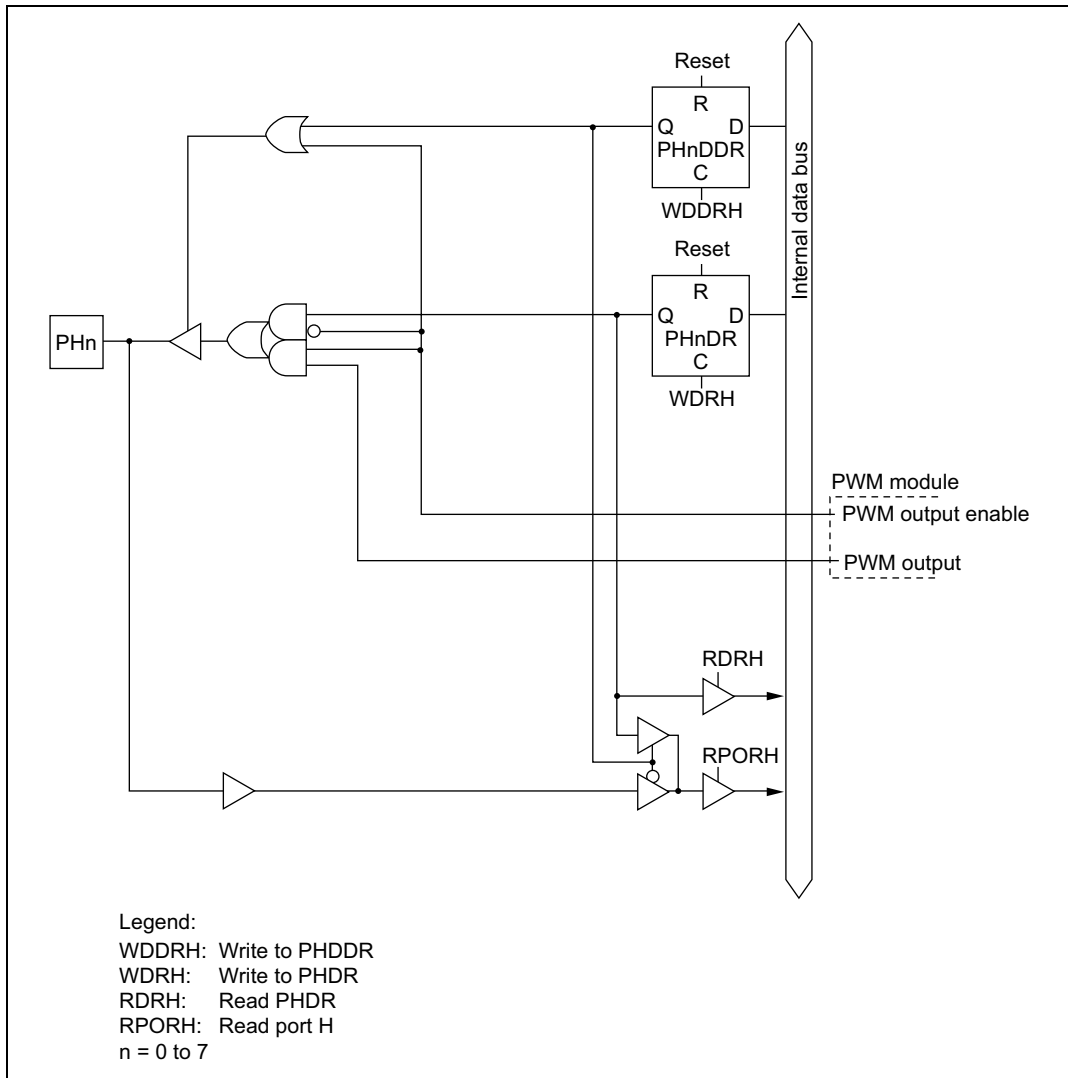

Figure C-11 Port H Block Diagram (Pins PH0 to PH7)

Appendix D Pin States

D.1 Port States in Each Mode

Table D-1 I/O Port States in Each Processing State

Port Name Pin Name	MCU Operating Mode	Reset	Hardware Standby Mode	Software Standby Mode	Program Execution State Sleep Mode
Port 1	4, 5	T	T	P10 to P13	P10 to P13
	6			[Address output, OPE = 0] T [Address output, OPE = 1] kept [Otherwise] kept	[Address output] A20 to A23 [Otherwise] I/O port
	7			P14 to P17 kept	P14 to P17 I/O port
Port 3	4 to 7	T	T	kept	I/O port
Port 4	4 to 7	T	T	T	Input port
Port 9	4 to 7	T	T	T	Input port
Port A	4, 5	L	T	[Address output, OPE = 0] T	[Address output] A19 to A17
	6	T	T	[Address output, OPE = 1] kept [Otherwise] kept	[Otherwise] I/O port
	7	T	T	kept	I/O port
Port B	4, 5	L	T	[Address output, OPE = 0] T	[Address output] A15 to A8
	6	T	T	[Address output, OPE = 1] kept [Otherwise] kept	[Otherwise] I/O port
	7	T	T	kept	I/O port

Port Name Pin Name	MCU Operating Mode	Reset	Hardware Standby Mode	Software Standby Mode	Program Execution State Sleep Mode	
Port C	4, 5	L	T	[OPE = 0] T [OPE = 1] kept	A7 to A0	
	6	T	T	[DDR = 1, OPE = 0] T [DDR = 1, OPE = 1] kept [DDR = 0] kept	[DDR = 1] A7 to A0 [DDR = 0] I/O port	
	7	T	T	kept	I/O port	
Port D	4 to 6	T	T	T	Data bus	
	7	T	T	kept	I/O port	
Port E	4 to 6	8 bit bus	T	T	kept	I/O port
		16 bit bus	T	T	T	Data bus
	7	T	T	kept	I/O port	
PF7/ ϕ	4 to 6	Clock output	T	[DDR = 0] T [DDR = 1] H	[DDR = 0] T [DDR = 1] Clock output	
	7	T	T	[DDR = 0] T [DDR = 1] H	[DDR = 0] T [DDR = 1] Clock output	
PF6/ \overline{AS}	4 to 6	H	T	[OPE = 0] T [OPE = 1] H	AS	
	7	T	T	kept	I/O port	
PF5/ \overline{RD} PF4/ \overline{HWR}	4 to 6	H	T	[OPE = 0] T [OPE = 1] H	RD, HWR	
	7	T	T	kept	I/O port	

Port Name Pin Name	MCU	Reset	Hardware	Software Standby Mode	Program Execution State Sleep Mode
	Operating Mode		Standby Mode		
PF3/ $\overline{\text{LWR}}$	4 to 6	H	T	[OPE = 0] T	LWR
	7	T	T	[OPE = 1] H kept	I/O port
PF0	4 to 7	T	T	kept	I/O port
Port H	4 to 7	T	T	kept	I/O port
Port J	4 to 7	T	T	kept	I/O port
HTxD0, HTxD1	4 to 7	H	T	H	Tx output
HRxD0, HRxD1	4 to 7	Input	T	T	Rx output

Legend:

H: High level

L: Low level

T: High impedance

kept: Input port becomes high-impedance, output port retains state

DDR: Data direction register

OPE: Output port enable

Appendix E Timing of Transition to and Recovery from Hardware Standby Mode

Timing of Transition to Hardware Standby Mode

- (1) To retain RAM contents with the RAME bit set to 1 in SYSCR, drive the $\overline{\text{RES}}$ signal low at least 10 states before the $\overline{\text{STBY}}$ signal goes low, as shown below. $\overline{\text{RES}}$ must remain low until $\overline{\text{STBY}}$ signal goes low (delay from $\overline{\text{STBY}}$ low to $\overline{\text{RES}}$ high: 0 ns or more).

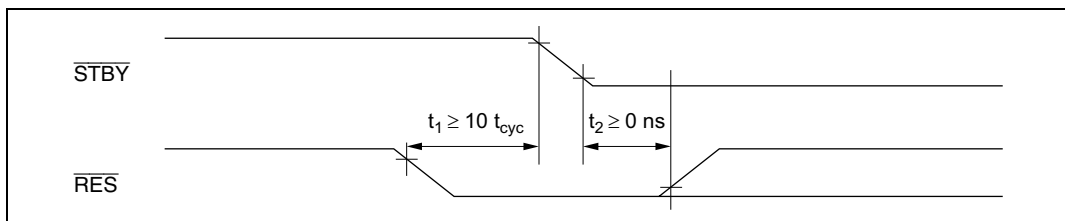

Figure E-1 Timing of Transition to Hardware Standby Mode

- (2) To retain RAM contents with the RAME bit cleared to 0 in SYSCR, or when RAM contents do not need to be retained, $\overline{\text{RES}}$ does not have to be driven low as in (1).

Timing of Recovery from Hardware Standby Mode

Drive the $\overline{\text{RES}}$ signal low and the NMI signal high approximately 100 ns or more before $\overline{\text{STBY}}$ goes high to execute a reset.

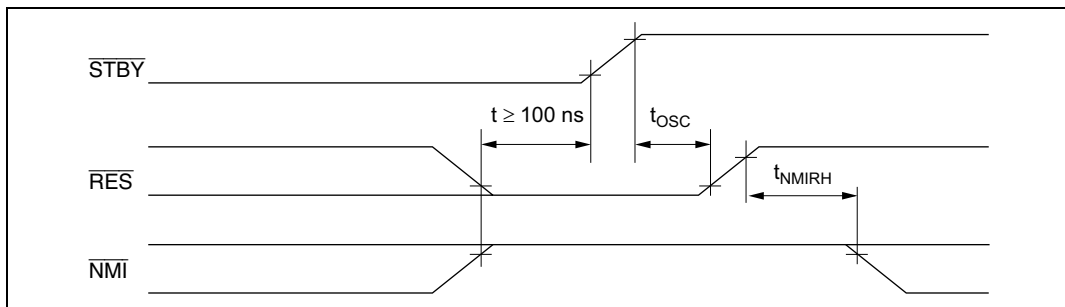

Figure E-2 Timing of Recovery from Hardware Standby Mode

Appendix F Product Code Lineup

Table F-1 H8S/2636, H8S/2638, H8S/2639, and H8S/2630 Product Code Lineup

Product Type		Product Code	Mark Code	Functions	Packages
H8S/2636	F-ZTAT version	HD64F2636	HD64F2636F	No subclock function	128-pin QFP (FP-128B)
			HD64F2636UF	Subclock function	128-pin QFP (FP-128B)
	Mask ROM version	HD6432636	HD6432636F	No subclock function	128-pin QFP (FP-128B)
			HD6432636UF	Subclock function	128-pin QFP (FP-128B)
H8S/2638	F-ZTAT version	HD64F2638	HD64F2638F	No subclock function or I ² C bus interface	128-pin QFP (FP-128B)
			HD64F2638UF	Subclock function, no I ² C bus interface	128-pin QFP (FP-128B)
			HD64F2638WF	Subclock function and I ² C bus interface	128-pin QFP (FP-128B)
	Mask ROM version	HD6432638	HD6432638F	No subclock function or I ² C bus interface	128-pin QFP (FP-128B)
			HD6432638UF	Subclock function, no I ² C bus interface	128-pin QFP (FP-128B)
			HD6432638WF	Subclock function and I ² C bus interface	128-pin QFP (FP-128B)
H8S/2639	F-ZTAT version	HD64F2639	HD64F2639UF	Subclock function, no I ² C bus interface	128-pin QFP (FP-128B)
			HD64F2639WF	Subclock function and I ² C bus interface	128-pin QFP (FP-128B)
	Mask ROM version	HD6432639	HD6432639UF	Subclock function, no I ² C bus interface	128-pin QFP (FP-128B)
			HD6432639WF	Subclock function and I ² C bus interface	128-pin QFP (FP-128B)

Product Type		Product Code	Mark Code	Functions	Packages
H8S/2630	F-ZTAT version	HD64F2630	HD64F2630F	No subclock function or I ² C bus interface	128-pin QFP (FP-128B)
			HD64F2630UF	Subclock function, no I ² C bus interface	128-pin QFP (FP-128B)
			HD64F2630WF	Subclock function and I ² C bus interface	128-pin QFP (FP-128B)
	Mask ROM version	HD6432630	HD6432630F	No subclock function or I ² C bus interface	128-pin QFP (FP-128B)
			HD6432630UF	Subclock function, no I ² C bus interface	128-pin QFP (FP-128B)
			HD6432630WF	Subclock function and I ² C bus interface	128-pin QFP (FP-128B)
H8S/2635	F-ZTAT version	HD64F2635	HD64F2635F	Subclock function, no I ² C bus interface	128-pin QFP (FP-128B)
			Mask ROM version	HD6432635*	HD6432635F
			HD6432634*	HD6432634F	Subclock function, no I ² C bus interface

Note: * Under development

Appendix G Package Dimensions

Figure G-1 shows the package dimensions of the H8S/2636, H8S/2638, H8S/2639, H8S/2630, H8S/2635, and H8S/2634.

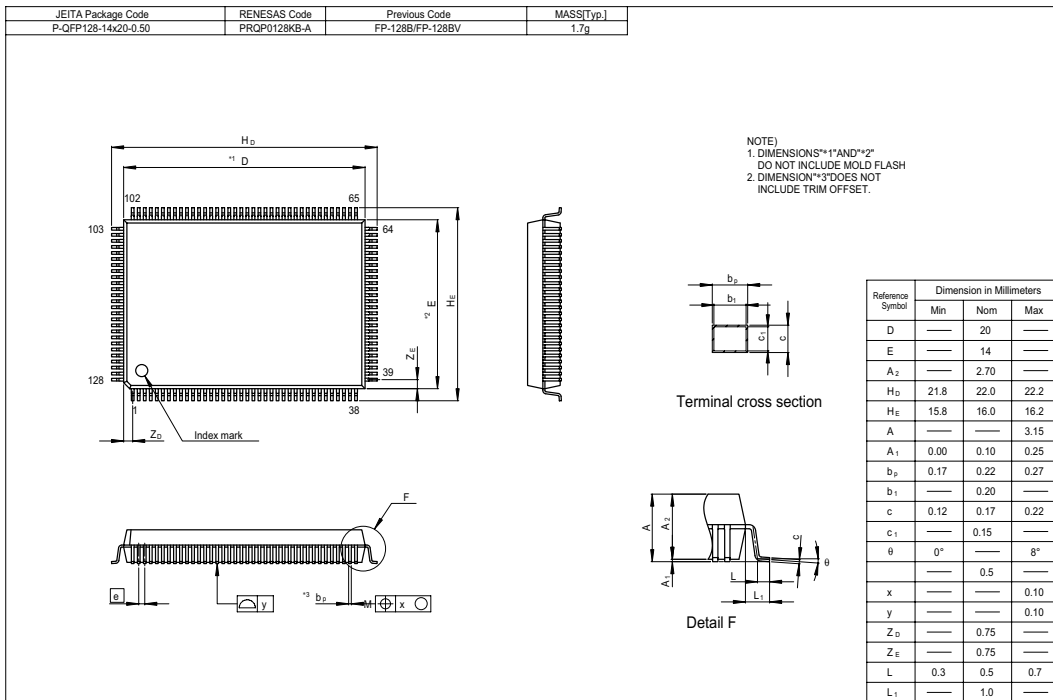

Figure G-1 FP-128B Package Dimensions

**Renesas 16-Bit Single-Chip Microcomputer
Hardware Manual
H8S/2639, H8S/2638, H8S/2636, H8S/2630, H8S/2635 Group**

Publication Date: 1st Edition, December 1999

Rev.6.00, February 22, 2005

Published by: Sales Strategic Planning Div.

Renesas Technology Corp.

Edited by: Technical Documentation & Information Department

Renesas Kodaira Semiconductor Co., Ltd.

Renesas Technology Corp. Sales Strategic Planning Div. Nippon Bldg., 2-6-2, Ohte-machi, Chiyoda-ku, Tokyo 100-0004, Japan

RENESAS SALES OFFICES



<http://www.renesas.com>

Refer to "<http://www.renesas.com/en/network>" for the latest and detailed information.

Renesas Technology America, Inc.

450 Holger Way, San Jose, CA 95134-1368, U.S.A
Tel: <1> (408) 382-7500, Fax: <1> (408) 382-7501

Renesas Technology Europe Limited

Dukes Meadow, Millboard Road, Bourne End, Buckinghamshire, SL8 5FH, U.K.
Tel: <44> (1628) 585-100, Fax: <44> (1628) 585-900

Renesas Technology Hong Kong Ltd.

7th Floor, North Tower, World Finance Centre, Harbour City, 1 Canton Road, Tsimshatsui, Kowloon, Hong Kong
Tel: <852> 2265-6688, Fax: <852> 2730-6071

Renesas Technology Taiwan Co., Ltd.

10th Floor, No.99, Fushing North Road, Taipei, Taiwan
Tel: <886> (2) 2715-2888, Fax: <886> (2) 2713-2999

Renesas Technology (Shanghai) Co., Ltd.

Unit2607 Ruijing Building, No.205 Maoming Road (S), Shanghai 200020, China
Tel: <86> (21) 6472-1001, Fax: <86> (21) 6415-2952

Renesas Technology Singapore Pte. Ltd.

1 Harbour Front Avenue, #06-10, Keppel Bay Tower, Singapore 098632
Tel: <65> 6213-0200, Fax: <65> 6278-8001



H8S/2639, H8S/2638, H8S/2636,
H8S/2630, H8S/2635 Group
Hardware Manual



Renesas Technology Corp.

2-6-2, Ote-machi, Chiyoda-ku, Tokyo, 100-0004, Japan